



(19) **United States**

(12) **Patent Application Publication**

Ball et al.

(10) **Pub. No.: US 2003/0062370 A1**

(43) **Pub. Date: Apr. 3, 2003**

(54) **CAN WITH PEELABLY BONDED CLOSURE**

(76) Inventors: **Melville Douglas Ball**, Kingston (CA);
Tom E. Scott, Port Angeles, WA (US);
Robin C. Furneaux, Banbury (GB);
James D. Moulton, Kingston (CA);
Christopher Robert Smith, Aurora, IL
(US); **Peter Hamstra**, Kingston (CA)

of application No. 09/603,004, filed on Jun. 26, 2000, now abandoned, which is a continuation-in-part of application No. 09/247,999, filed on Feb. 10, 1999, now abandoned.

Publication Classification

(51) **Int. Cl.⁷** **B65D 41/00**
(52) **U.S. Cl.** **220/359.2; 220/359.4**

Correspondence Address:
COOPER & DUNHAM LLP
1185 Ave. of the Americas
New York, NY 10036 (US)

(57) **ABSTRACT**

(21) Appl. No.: **10/150,683**

(22) Filed: **May 17, 2002**

Related U.S. Application Data

(63) Continuation-in-part of application No. 09/905,310, filed on Jul. 13, 2001, which is a continuation-in-part

A metal can for holding a carbonated or otherwise pressurized beverage or the like, having a rigid metal lid formed with an eccentrically disposed, upwardly projecting annular flange defining an aperture of average diameter between about 0.625 inch and about 1 inch, and a flexible metal foil closure extending over the aperture and peelably bonded by a heat seal to the sloping outer surface of the flange.

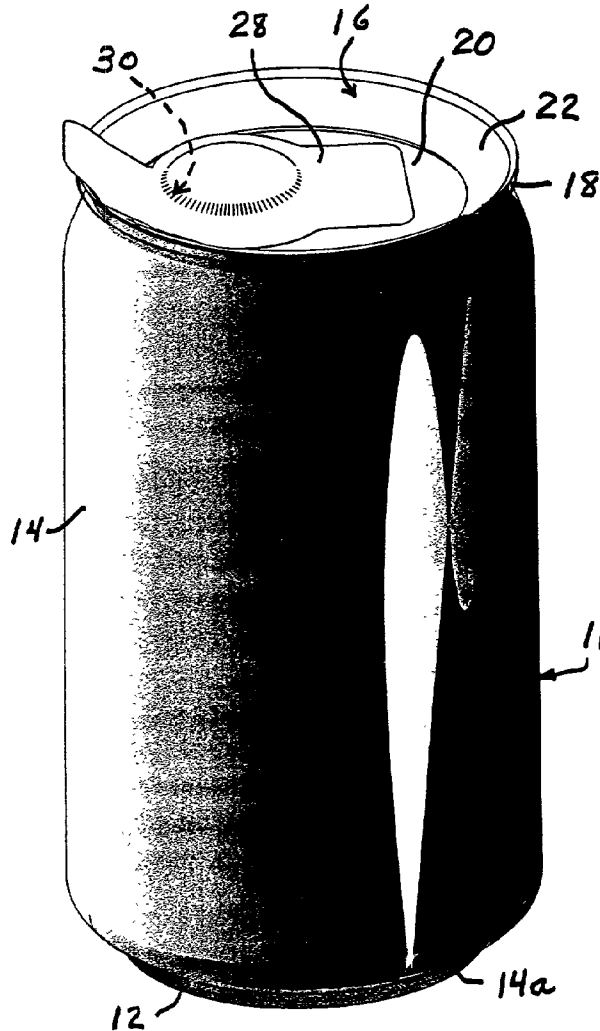

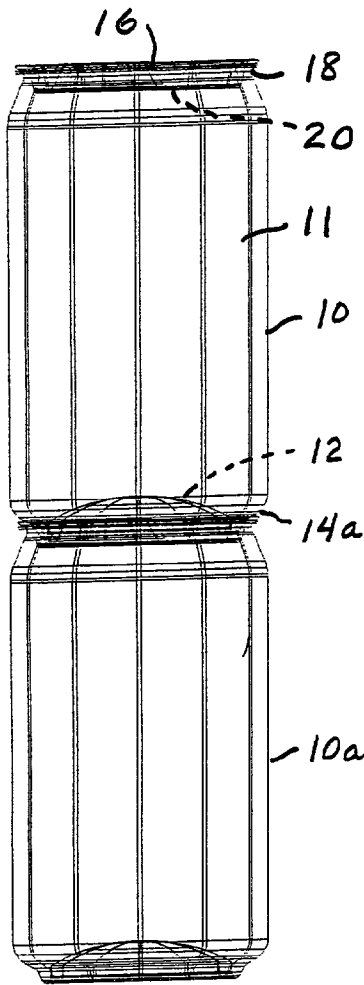

FIG. 8

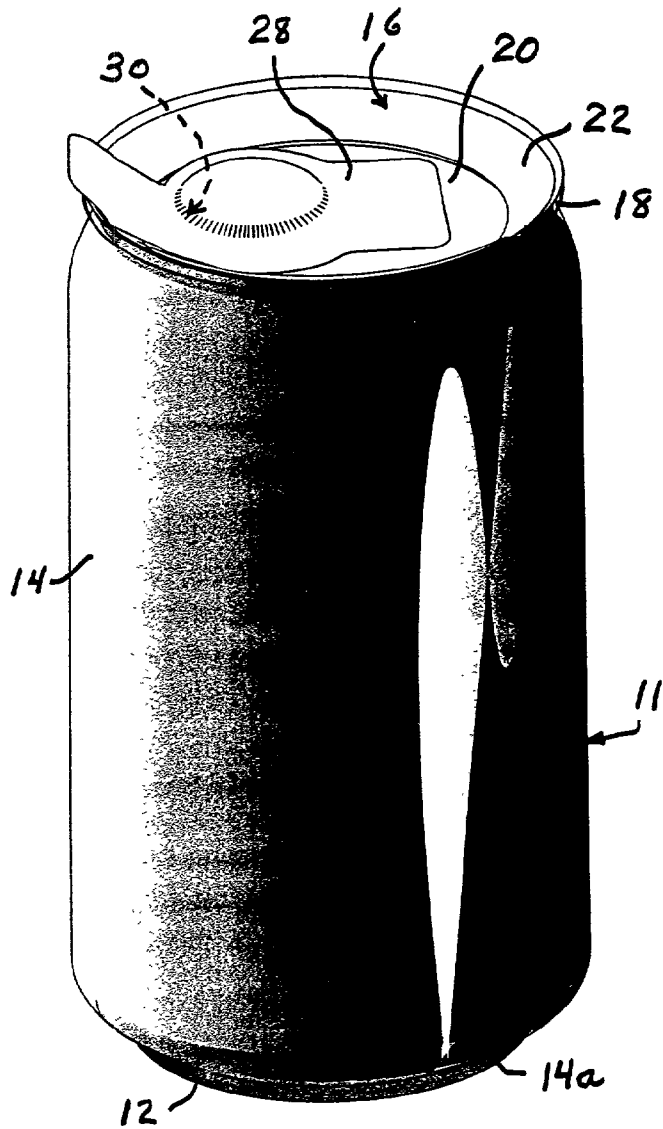

FIG. 1

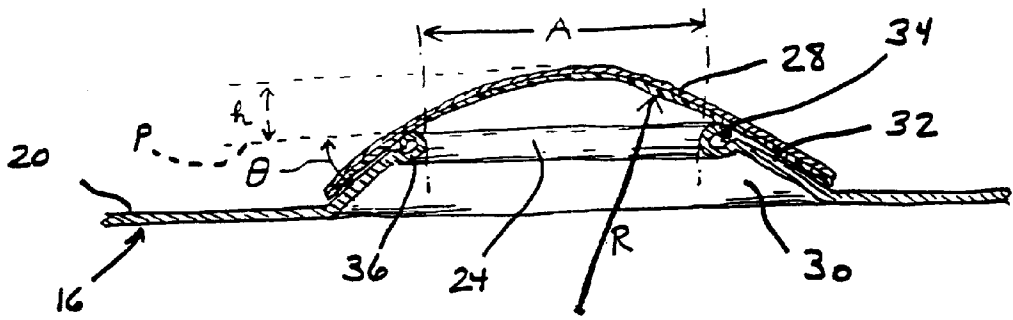

FIG. 2A

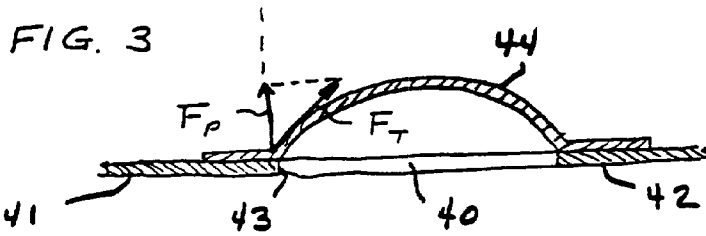

FIG. 3

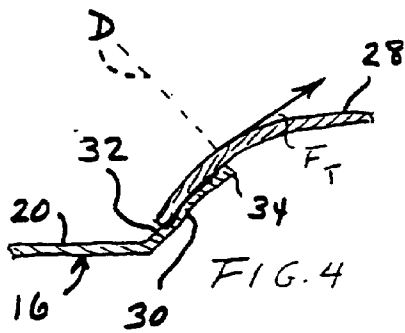

FIG. 4

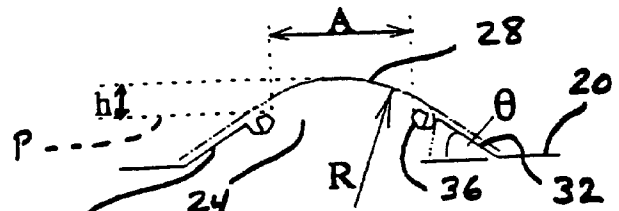

FIG. 2B

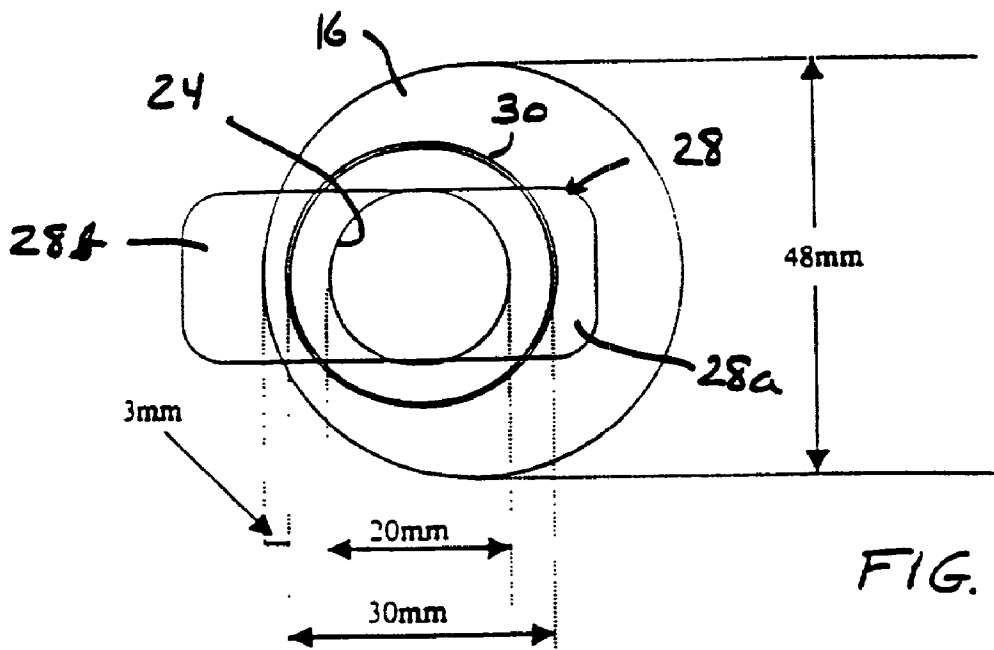

FIG. 5

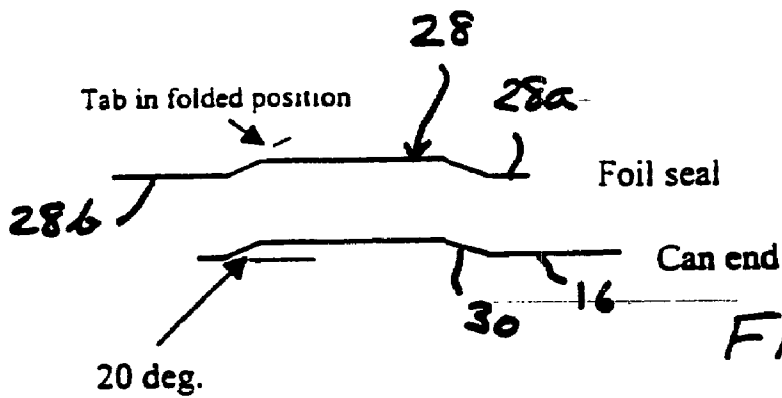

FIG. 6

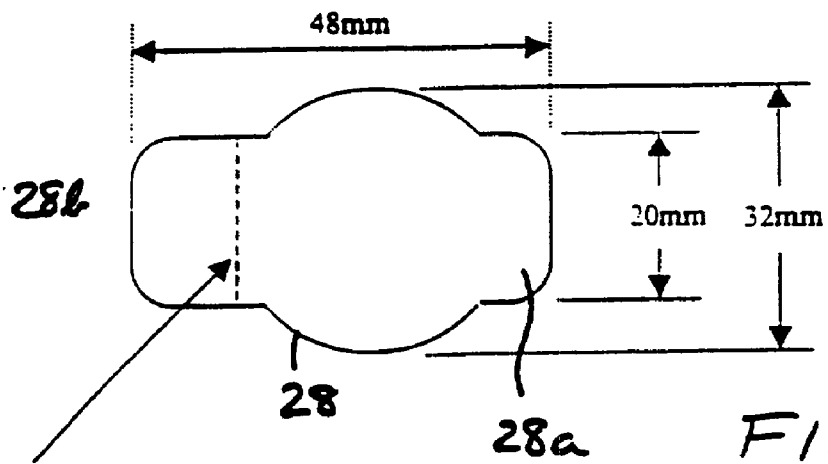
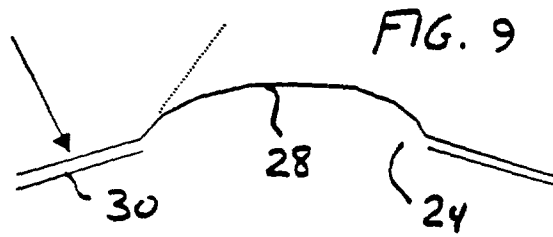

FIG. 7



Peel Strength for Can End Sheet heat sealed to
50 micron foil (TH388 coating)

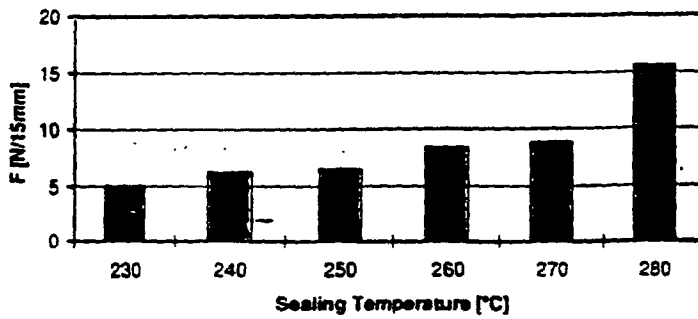

FIG. 10

Novel Can End - Easy Peel

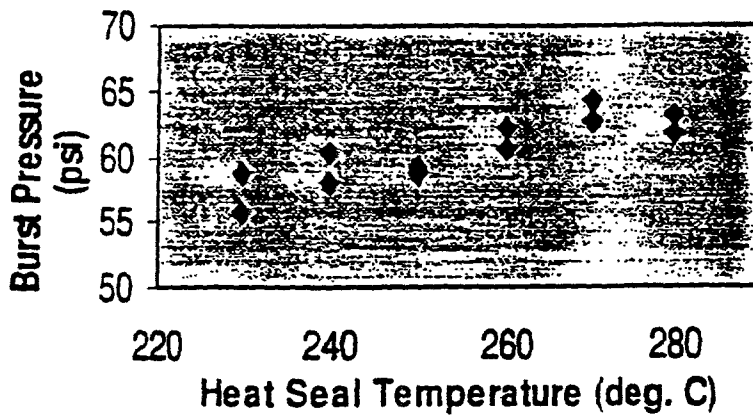

FIG. 11

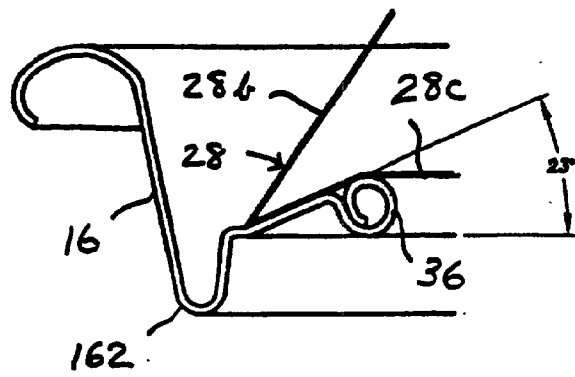

FIG. 12

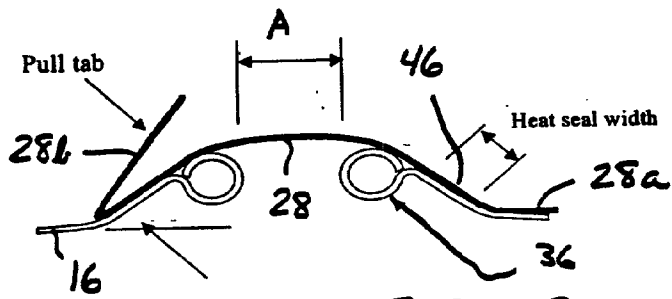

FIG. 13

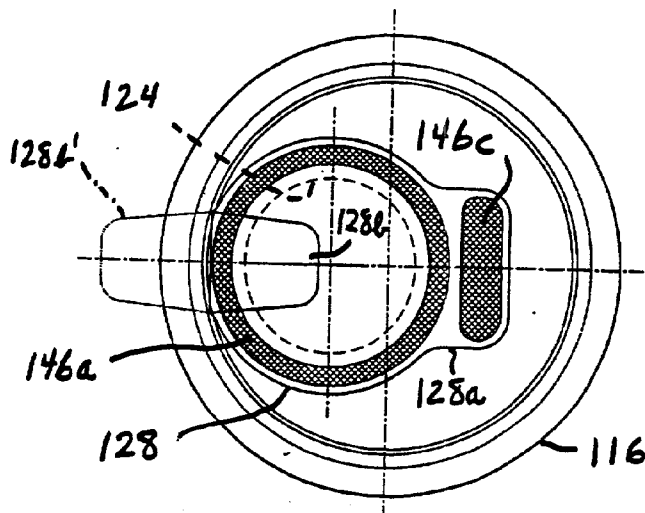

FIG. 15

Bulge Height vs. Pressure
7/8" diameter aperture
(~1" diameter for inner edge of heat seal)
100 micron foil

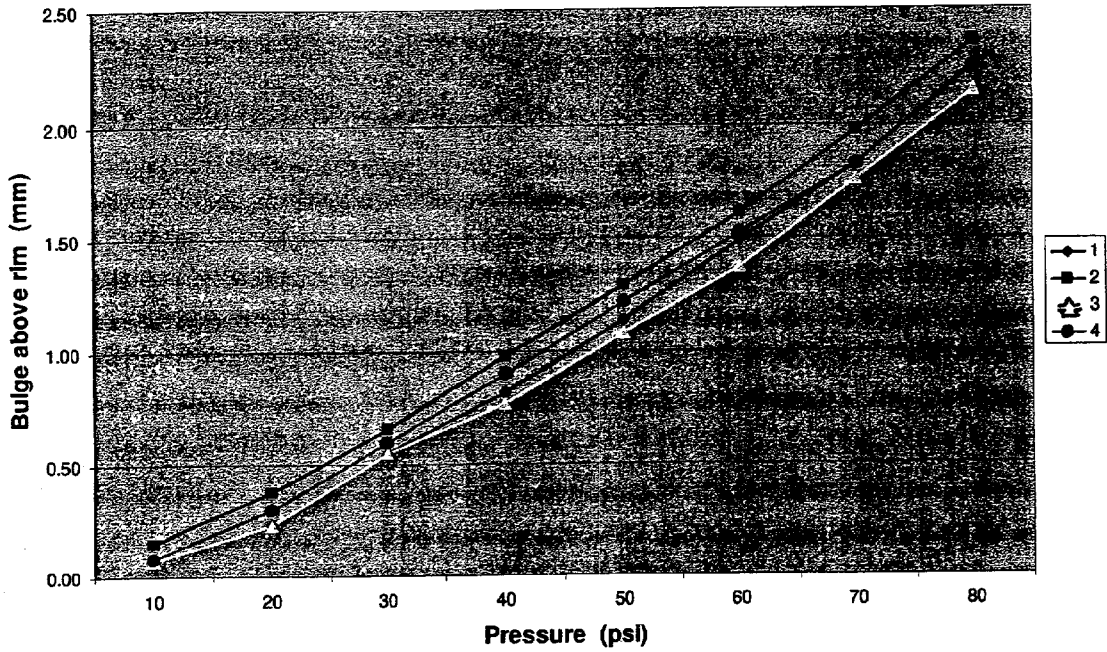

FIG. 14

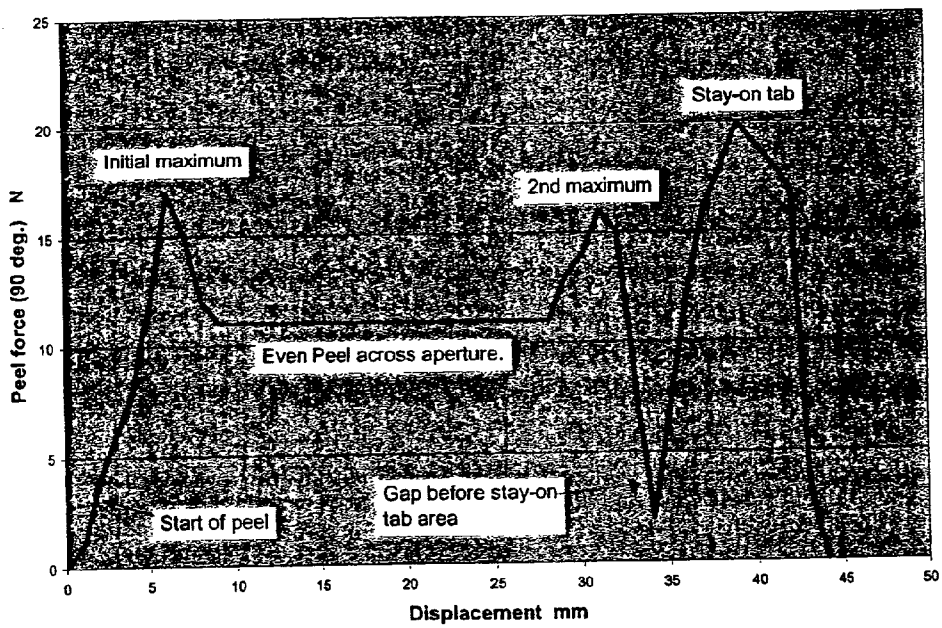
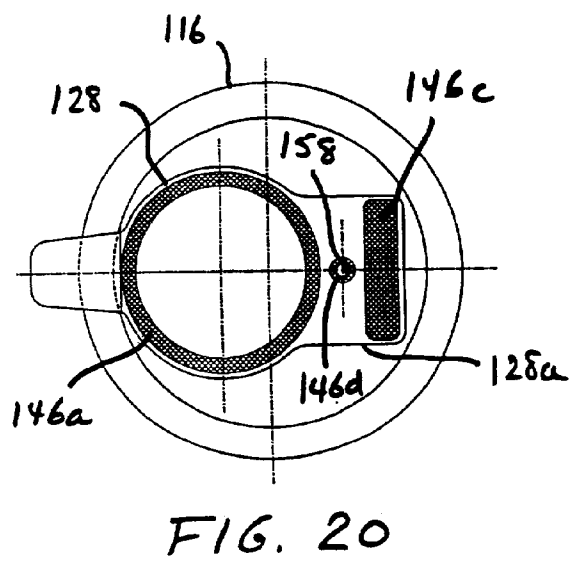
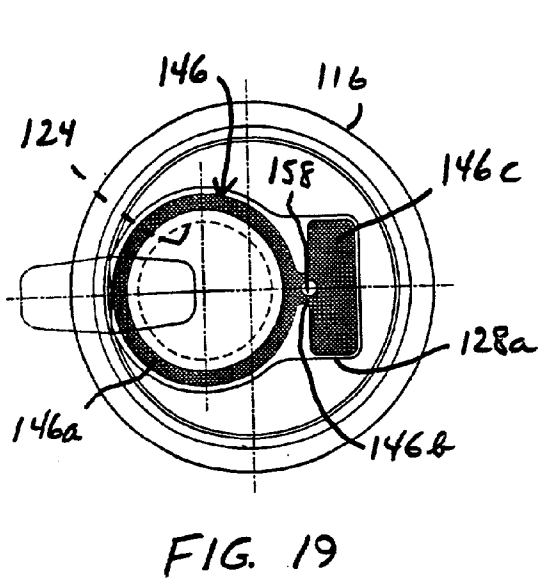
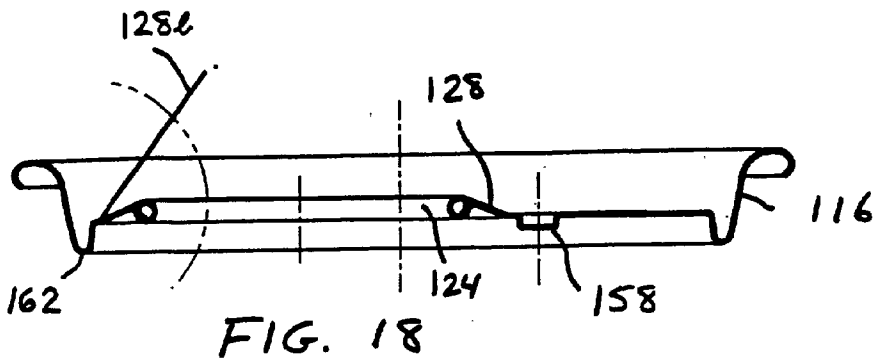
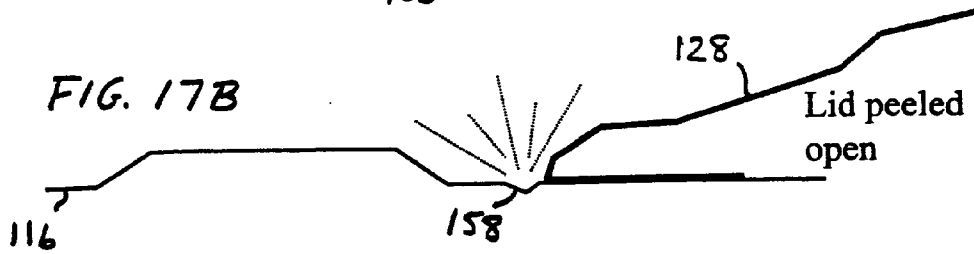
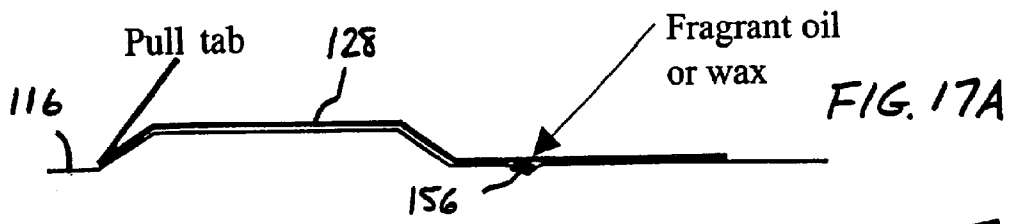

FIG. 16



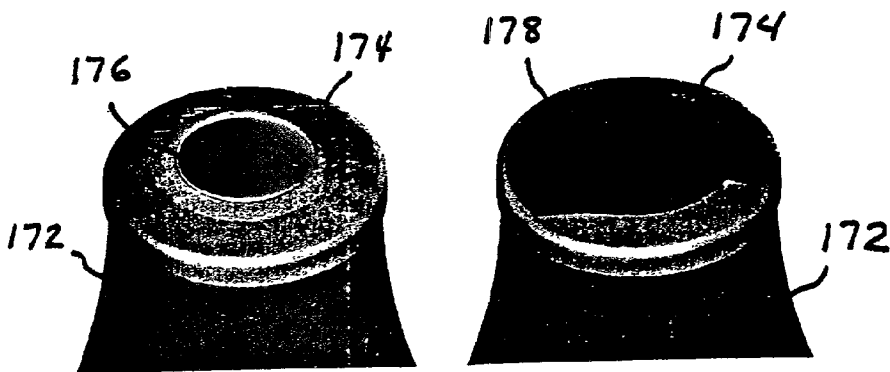
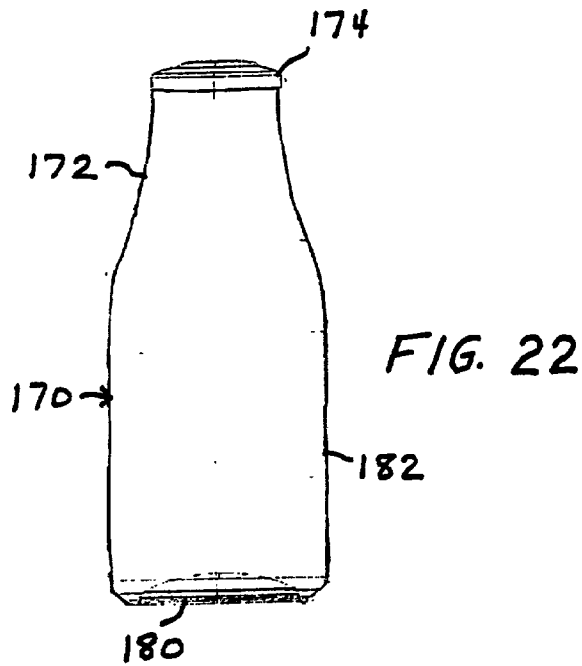
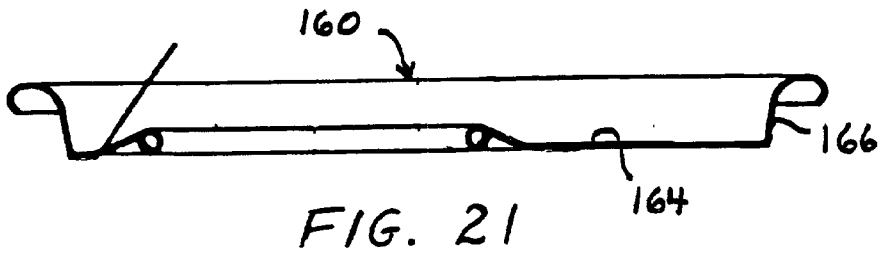

FIG. 24

FIG. 23

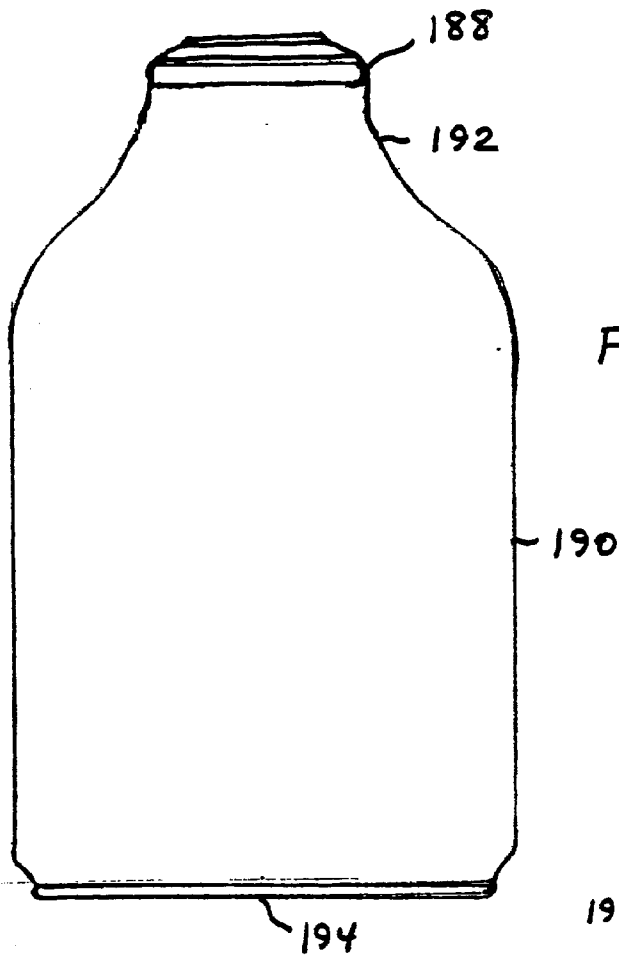
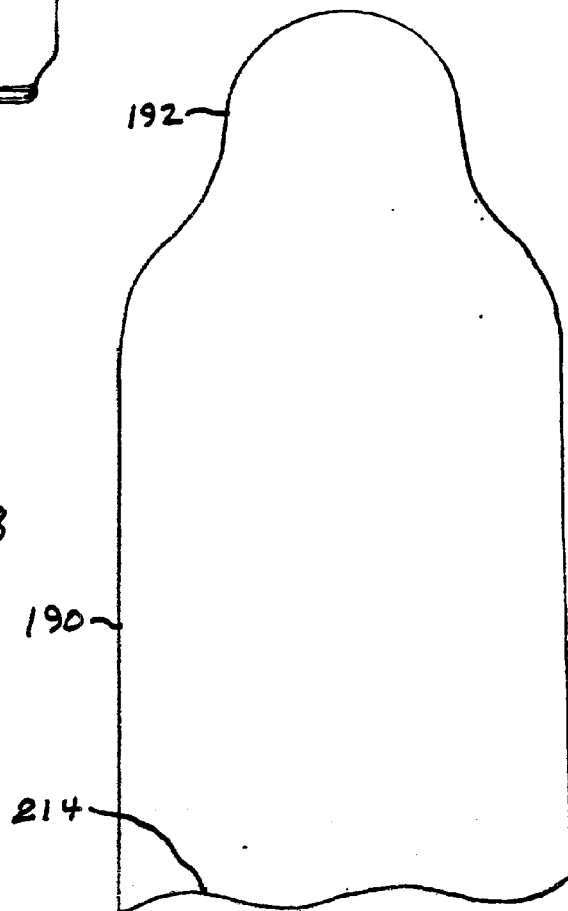

FIG. 25

FIG. 28



PRIOR ART

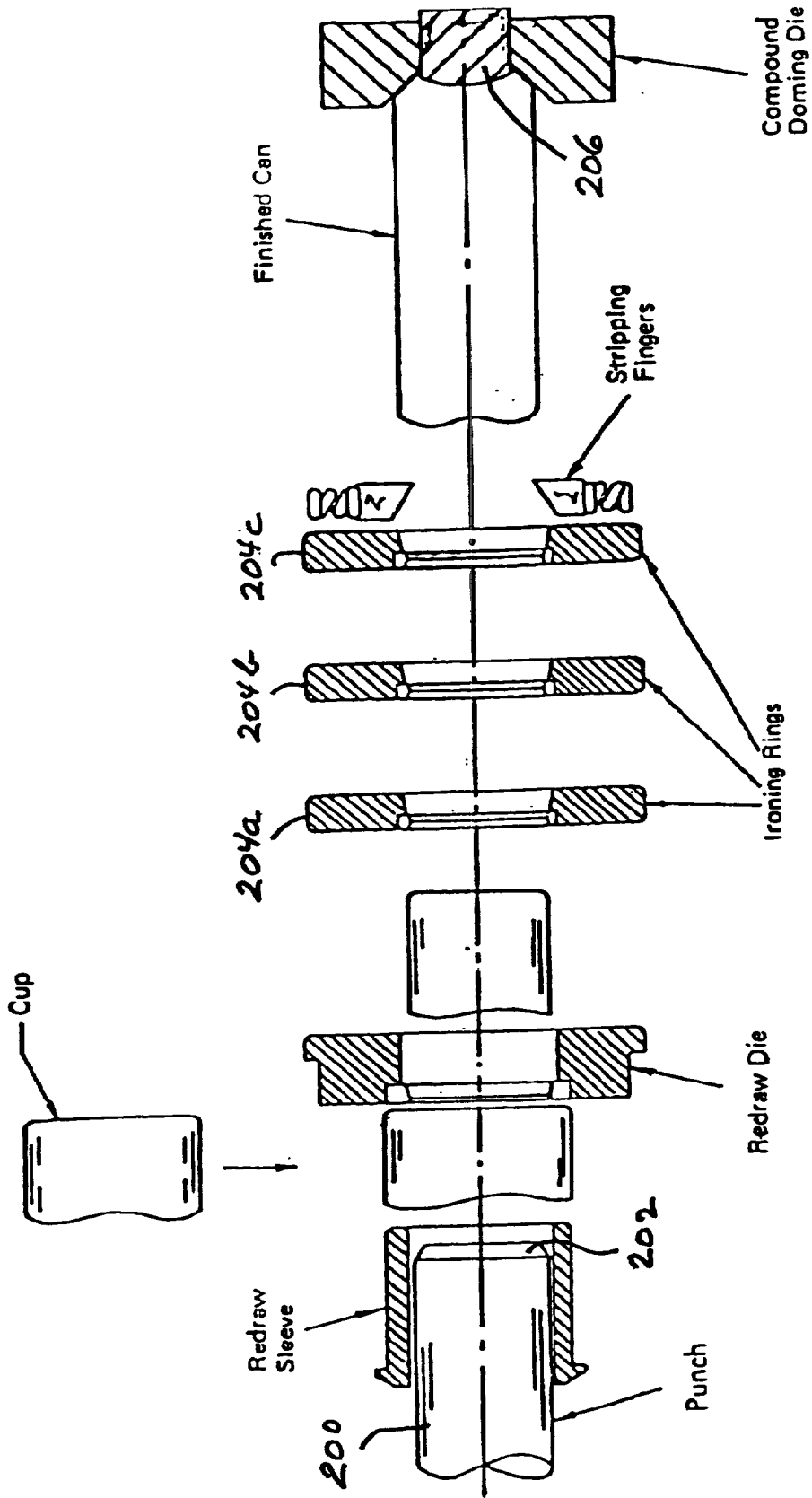

FIG. 26

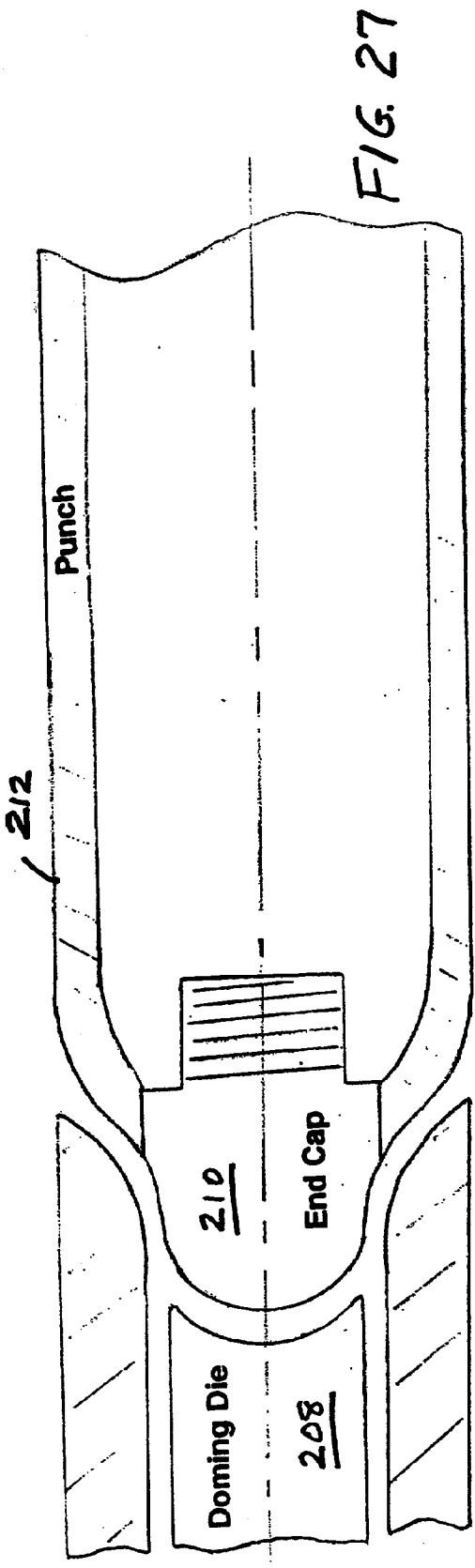

FIG. 27

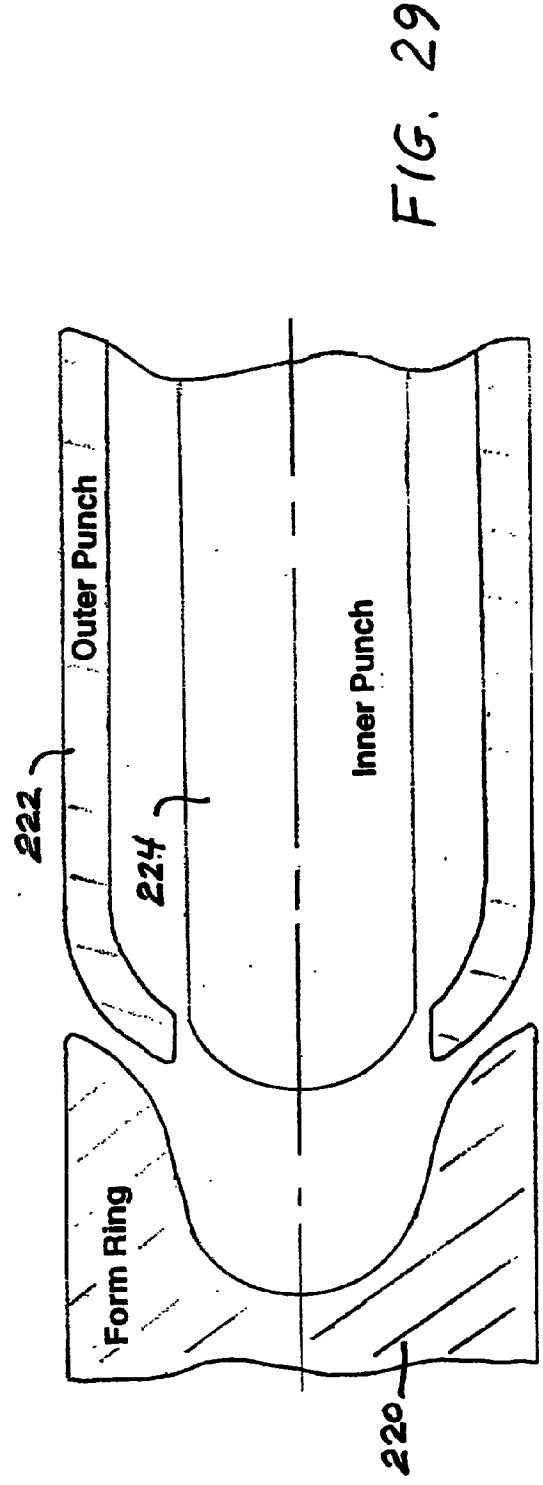
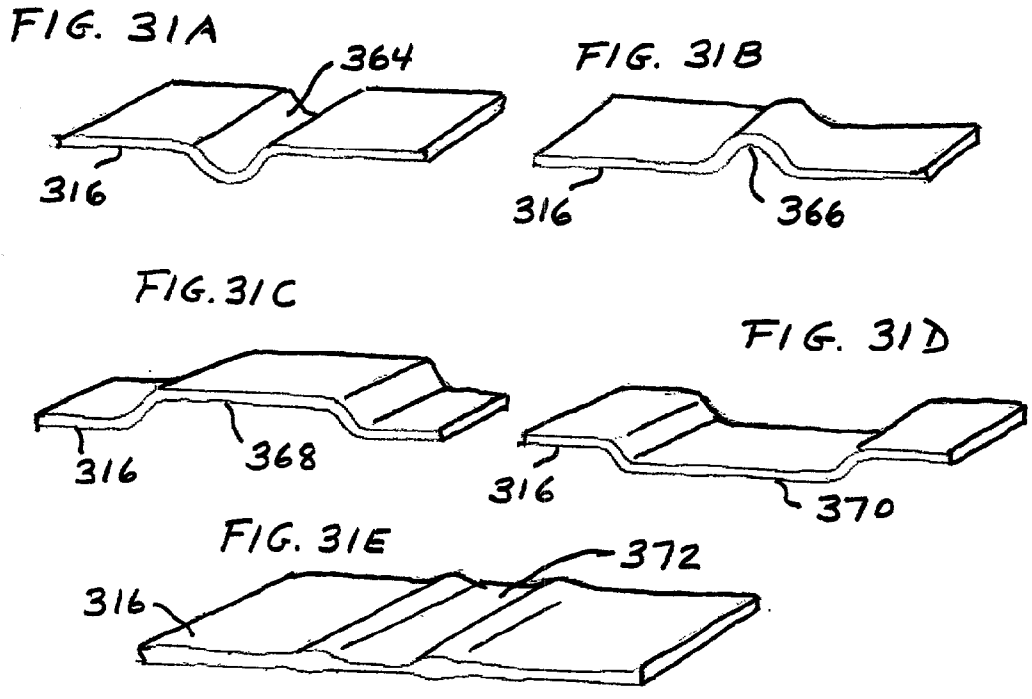
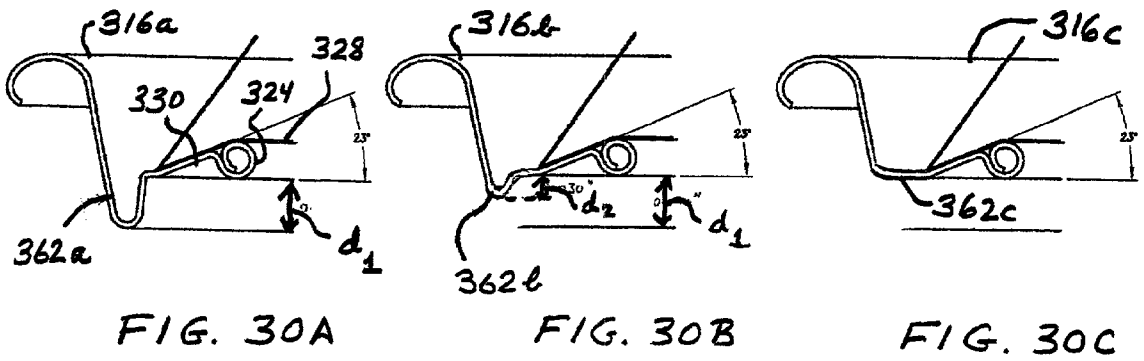
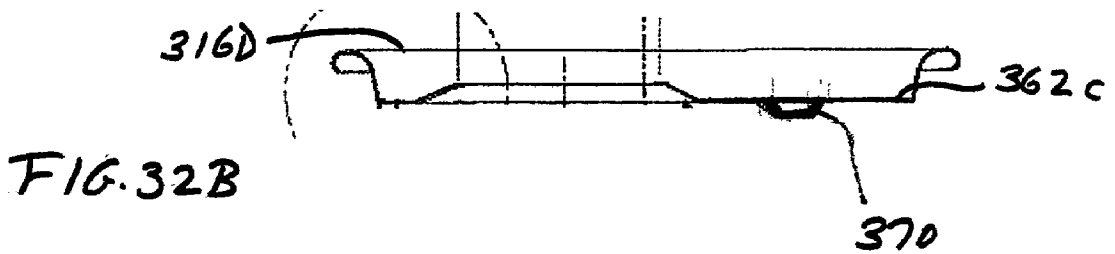
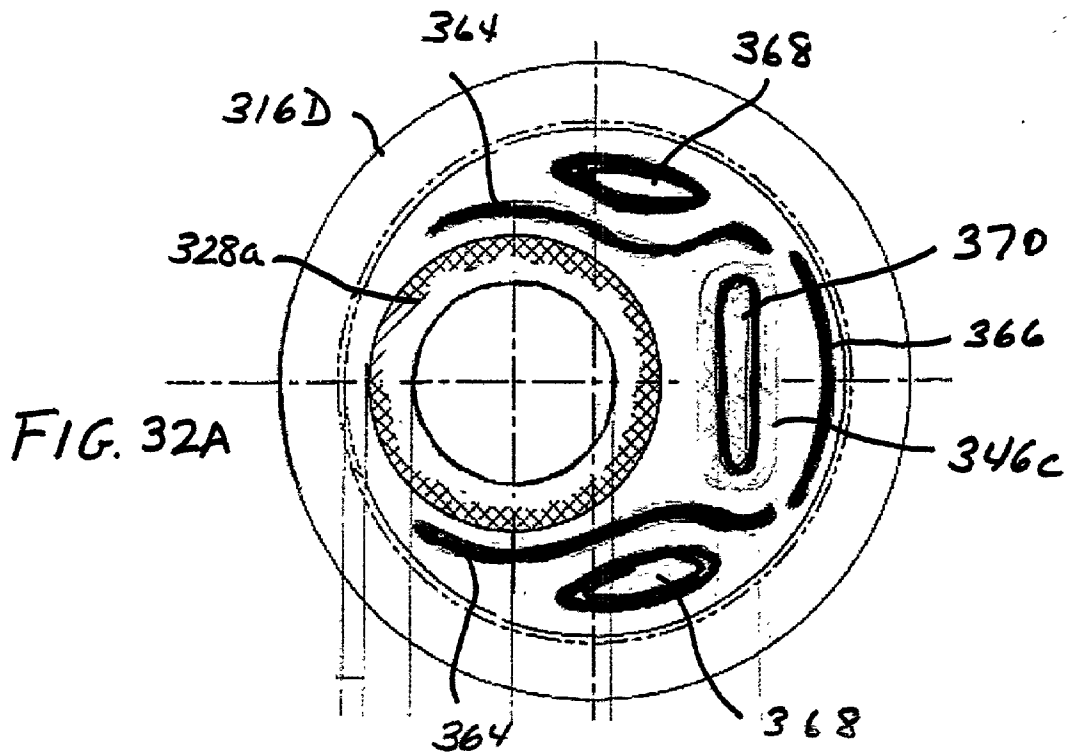

FIG. 29





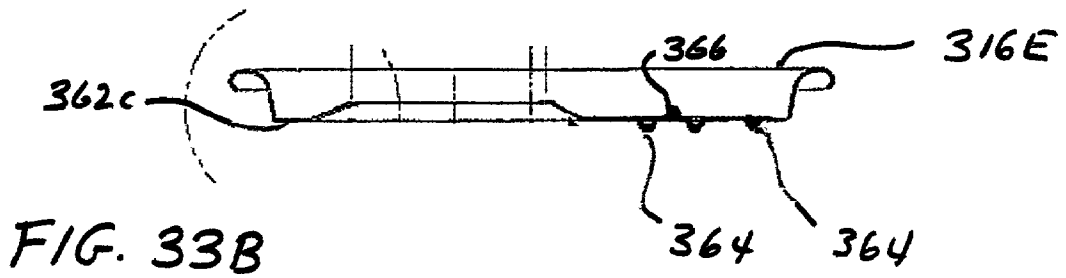
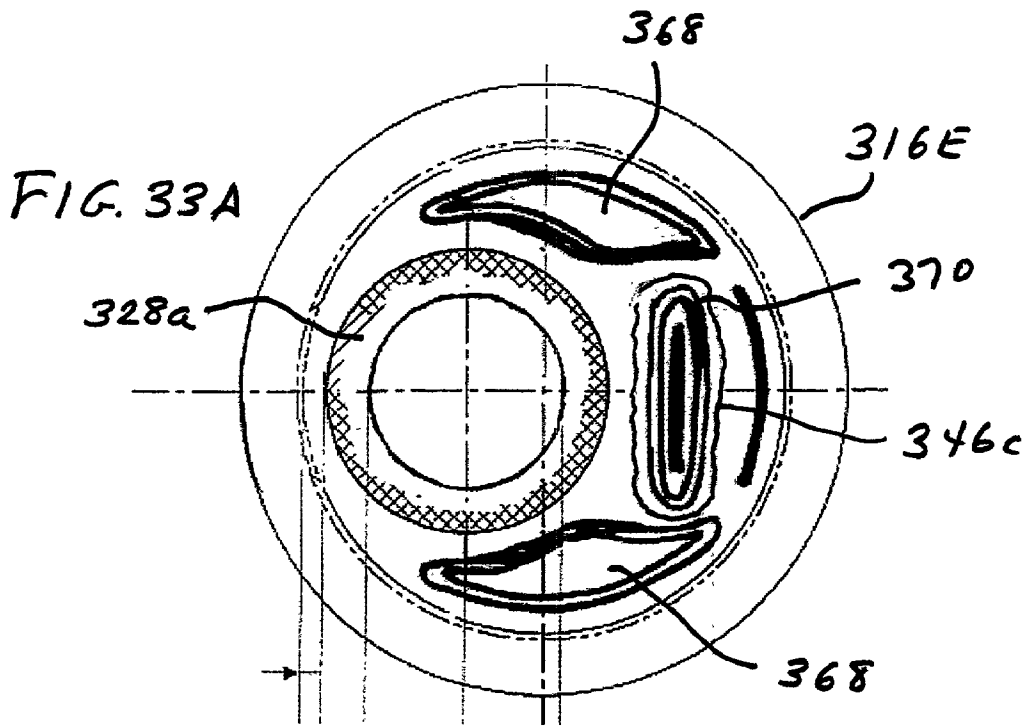

FIG. 34A

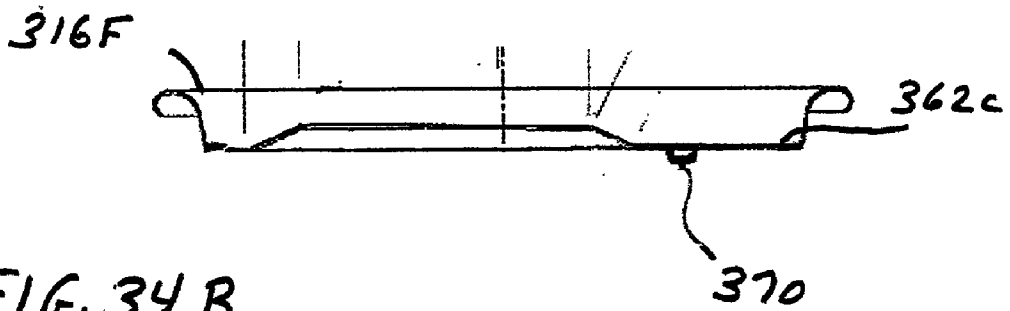
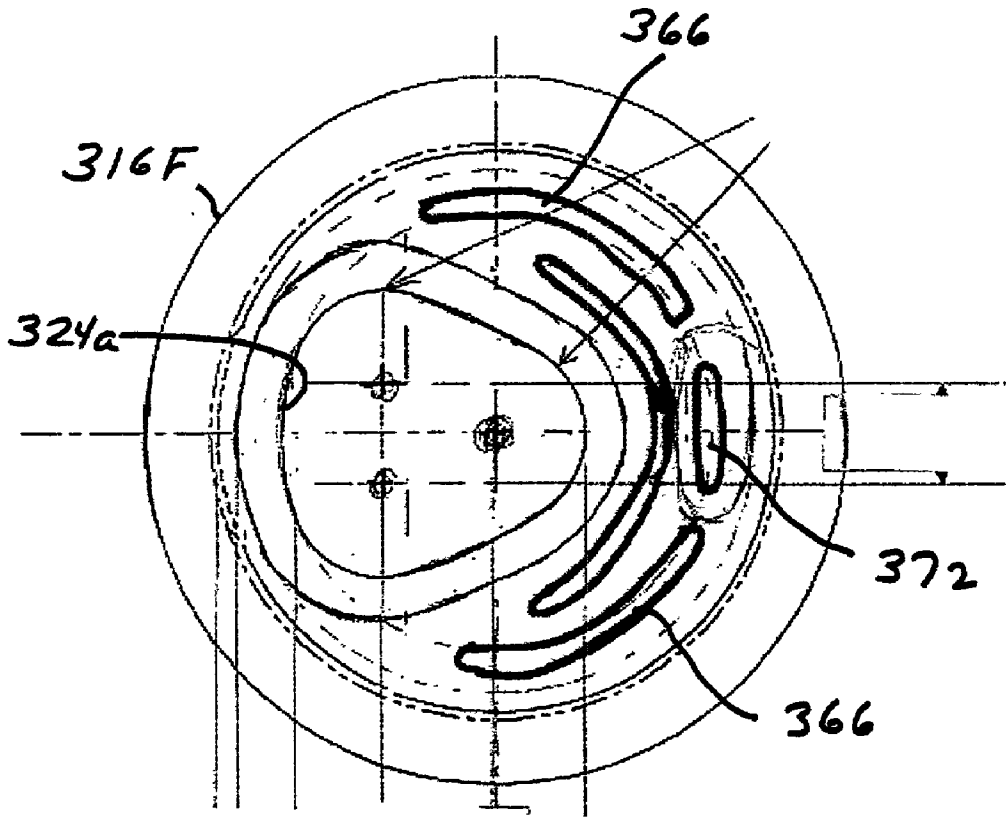

FIG. 34B

CAN WITH PEELABLY BONDED CLOSURE

CROSS REFERENCE TO RELATED APPLICATIONS

[0001] This application is a continuation-in-part of copending U.S. patent application Ser. No. 09/905,310, filed Jul. 13, 2001, which is a continuation-in-part of U.S. patent application Ser. No. 09/603,004, filed Jun. 26, 2000 (now abandoned), which is a continuation-in-part of U.S. patent application Ser. No. 09/247,999, filed Feb. 10, 1999 (now abandoned), the entire disclosures of all of the aforesaid applications being incorporated herein by this reference.

BACKGROUND OF THE INVENTION

[0002] This invention relates to cans, and more particularly to metal cans having an apertured lid with a heat-sealed, peelable closure for the aperture. In an important specific aspect it is directed to heat-sealed-closure type cans for holding carbonated beverages or like contents that exert a positive internal pressure on the closure, and also to lids for such cans, carbonated beverage-containing packages including such cans, and methods of producing such cans containing carbonated beverages.

[0003] Heat sealable containers are widely used for a variety of high quality food products. Non-retorted products packaged with heat sealable foil lidding include many types of jams, preserves, yogurt and dairy products, peanuts and snack foods. A wide variety of retortable fish and meat products (including many varieties of pet food) are also packaged using heat sealed foil lidding. In some instances, the entire lid of a can or like container may be removably bonded by heat sealing to a flange formed at an open upper end of the container body, so as to enable the lid to be completely removed, for access to the contents of the container. Other containers, exemplified by cans of tomato or like quiescent fruit juices, have a lid permanently secured to the container body and formed with an aperture (for pouring out the contents) covered by a heat sealed closure or, more commonly, by a closure bonded with a pressure sensitive adhesive. Such a closure is commonly a thin, flexible element, e.g. an aluminum foil-polymer laminate, peripherally bonded by heat sealing to a flange defining the aperture, and has a tab that enables the closure to be peeled manually from the flange; the flange may be a flat portion of the can lid surrounding the aperture and coplanar with the aperture edge.

[0004] For easy opening, typical peel forces (at 90° to the flange) for a heat sealed closure are in a range between about 2 lbs. (≈ 9 Newtons) and 4 lbs. (18 Newtons) and preferably about 2½ lbs. (≈ 11.3 Newtons).

[0005] Some containers with heat sealed closures are subjected to a retorting process after filling to sterilize the food or beverage. The retort process involves pressure differentials (from inside to outside) of up to 30 psi (≈ 2 bar), although for many applications, a counter pressure system is used to prevent the lid or closure from bursting off the container. This is necessary because of the reduction in bond strength which generally occurs at the elevated retort temperatures. Moreover, in the case of containers with a lid or closure heat sealed to a flange which is coplanar with the container aperture, internal pressure will cause the lid or

closure to bulge over the aperture and, in turn, this bulging exerts a peel force on the heat seal.

[0006] Carbonated soft drinks require a container capable of withstanding internal pressures of 90 psi or higher. Such pressures, or even substantially lesser positive internal pressures, would exert on a conventional heat sealable closure a peeling force more than sufficient to cause burst failure. Increasing the strength of the heat seal bond sufficiently to withstand such forces would make manual peeling of the closure difficult or virtually impossible for many consumers. Consequently, heat sealable closures have not had wide commercial use with canned carbonated beverages. In present-day commercially available carbonated soft drink cans, having a so-called drawn-and-ironed aluminum alloy can body and an aluminum alloy can lid peripherally secured to the open upper end of the body, the can end is commonly formed with a scored area and provided with a riveted tab system which, when lifted, creates a lever action and exerts a downward force that generates a fracture along a scored line thereby creating an aperture. The region of the lid that lies within the scored area is simultaneously bent down into the top of the container.

[0007] A conventional can end or lid provided with a riveted tab and scored area must be fabricated from sheet which has sufficient strength and formability to meet the requirements. In particular, the gauge, alloy and temper must be chosen to meet the demands of the rivet-forming operation, to enable the scoring (which typically has a depth equal to about half the thickness of the lid) to withstand internal pressures which may exceed 90 psi (≈ 6 bar), and to impart sufficient strength to the rivet area of the lid so that the score line can be ruptured by manual application of a leveraged force using the tab. The aluminum alloy designated AA5182, rolled to about 0.0086" ($\approx 218\mu$) gauge currently meets these requirements in the most cost effective way. However, compared to some other sheet alloy products (for example, AA3104 can body sheet), it is quite costly. This is due in part to the comparatively high magnesium content ($\approx 4.5\%$ by weight) and also due to the more costly rolling practices which are necessary for this alloy. Moreover, during recycling and remelting operations, magnesium is preferentially oxidized, and therefore lost in the dross. This means that metal from recycled used beverage containers (UBCs) is not suitable for can end sheet production unless costly additions of magnesium are made to compensate for this magnesium loss.

[0008] In addition, the full can end must have sufficient strength and rigidity when attached to the can so that it will not buckle, reverse or deflect excessively under the stresses applied by the internal pressure from the contained beverage; the larger the area of a can lid, the greater is the strength necessary to prevent deflection and buckling or reversal. In recent years, there has been some reduction in commercial can end (lid) diameter, with concomitant reduction in lid gauge and area, affording savings in amount of metal used per lid. However, a conventional can lid must have a diameter large enough to accommodate the tab and the centrally positioned rivet as well as a scored area of sufficient size to provide the desirably large aperture currently preferred for pouring or drinking; this consideration has constrained the extent to which the diameter of conventional lids can be reduced. Also, even with the limited lid diameter reduction heretofore achieved, a conventional lid is ordi-

narily formed with a peripheral countersink to aid in minimizing deflection and reduce the likelihood of buckling or reversal of the lid, although the presence of the countersink (unavoidably near the location of drinking or pouring) is disadvantageous from a hygienic standpoint in that, especially during storage, it may collect dirt and foreign matter.

[0009] Another disadvantage of the riveted tab - scored area system is that the score line is vulnerable to corrosive attack. Scoring of the can end cuts through the protective layer of lacquer and exposes a crevice of unprotected metal. Any spillage or contamination of this score line by a beverage or other liquid may initiate localized corrosive attack.

[0010] Alternative structures have heretofore been proposed or produced with the objective of enabling use of heat sealable closures with containers for carbonated beverages or other substances that create elevated internal pressure. For instance, it has been proposed to provide a spherically domed (rather than planar) lid having an aperture covered by a similarly spherically curved closure member bonded thereto, or to provide a container in which the entire lid is heat-sealed to an angled (rather than planar) flange around the container periphery. In a further alternative, a can lid has been provided with plural small holes (rather than a single aperture) covered by a single foil laminate seal with a pull tab. These alternatives, however, have various limitations or drawbacks.

[0011] U.S. Pat. No. 3,889,844 describes a can closure in which a can end is shaped to impart a frustoconical area around a pour hole sealed with an adhesive tape tab so that the forces acting on the tape (exerted by can contents under pressure, such as carbonated beverages) tend to place the adhesive in shear instead of in peel. The size of the pour hole described in this patent provides a pour rate which is low as compared to present-day conventional carbonated beverage cans with scored can ends, and the attainment of long shelf life at pressures as high as 90 psi is not shown.

SUMMARY OF THE INVENTION

[0012] The present invention, in a first aspect, broadly contemplates the provision of a can comprising a metal can body having an open upper end; a substantially rigid metal can lid secured at its periphery to and closing the can body end, the lid having an upper surface; an annular flange formed in a portion of the lid and projecting upwardly from the lid upper surface, the flange having an upwardly sloping outer surface and an annular inner edge lying substantially in a plane and defining an aperture with an average diameter between about 0.625 inch and about 1 inch; and a flexible closure member of a material comprising a metal foil, extending entirely over the aperture and peelably bonded by a heat seal to the flange outer surface entirely around the aperture.

[0013] In currently preferred embodiments of the invention, the lid has a substantially flat upper surface. It is also strongly currently preferred that the aperture be circular, because in noncircular apertures there are locations around the perimeter where the tendency of the closure member to peel (burst) is enhanced. The "average diameter" in the case of a circular aperture is, of course, simply the diameter of the aperture.

[0014] It will be understood that directions such as "upper" or "upwardly" are used herein with reference to a can standing upright with the lid at the top.

[0015] Further in accordance with the invention, in currently preferred embodiments thereof, the flange outer surface is oriented at an angle of slope between about 12.5° and about 40° to the plane of the annular inner edge (aperture edge) of the flange; a currently especially preferred range for the angle is between about 20° and about 35°. The term "angle of slope" refers to the acute angle formed between the plane of the aperture edge and the line representing the flange outer surface as seen in a vertical plane intersecting the aperture edge at a point at which the line tangent to the aperture edge in the plane of the aperture edge is perpendicular to the vertical plane. The sloping outer surface of the annular flange may be straight-sided, i.e. frustoconical, or curved; if the surface is curved, the angle of slope is the angle of the line tangent thereto, in the aforesaid vertical plane, immediately adjacent the aperture edge.

[0016] When the can is filled with a carbonated beverage, the closure member is subjected to a differential pressure (hereinafter sometimes designated Δp), i.e. a positive difference between the pressure within the can and ambient pressure outside the can, in some circumstances as high as 90 psi or even more. This differential pressure exerts, on the closure member and heat seal, a force having a tear/shear component (i.e., tending to tear the closure member and shear the heat seal, such component being hereinafter referred to as the tear/shear force and being sometimes designated γ), and in some cases also a peel component.

[0017] In currently preferred embodiments of the invention, the closure member material is deformable, and the average diameter of the aperture, the angle of slope of the flange, and the deformability of the material are mutually selected such that the closure member, when subjected to differential pressures up to at least about 90 psi (preferably up to at least about 100 psi) in the can, bulges upwardly with an arc of curvature such that a line tangent to the arc at the inner edge of the flange lies at an angle (to the plane of the flange inner edge) not substantially greater than the angle of slope of the flange outer surface, thereby to eliminate any peel component of the force exerted by the differential pressure on the closure member and heat seal.

[0018] Also, in some currently preferred embodiments, the closure member and heat seal have a tear/shear force resistance of at least about 75 lb./in., and the average diameter of the aperture and the angle of slope of the flange are mutually selected such that when the closure member is subjected to differential pressure of up to at least about 90 psi (preferably up to at least about 100 psi) within the can, the tear/shear force exerted on the closure member and heat seal does not exceed the aforesaid tear/shear force resistance.

[0019] As a further particular feature of the invention, in currently preferred embodiments, the annular inner edge of the flange is formed with a reverse bead curl, which may be substantially tangent to the upwardly sloping outer surface of the flange.

[0020] Conveniently and advantageously, in at least many instances, the metal foil of the closure member is aluminum alloy foil, e.g. having a thickness between about 0.002 inch

($\approx 50\mu$) and about 0.004 inch ($\approx 100\mu$). Also advantageously, the heat seal may be formed as an annulus surrounding the aperture and having a width between about 0.079 inch and about 0.118 inch (about 2 to 3 mm). This width of heat seal is found to be sufficient to withstand tear/shear forces encountered in use, and at the same time it facilitates manual peeling of the closure member to open the aperture. To enable such peeling without difficulty, the 90° peel strength of the heat seal is between about 8 and about 20 N, preferably between about 10 and about 16 N. The closure may be provided with a tab portion having a manually graspable free end.

[0021] In contrast to the riveted tab structure of conventional carbonated beverage cans, a heat-sealable closure member may become completely separated from the can upon opening, and may then be separately discarded, creating environmental problems. To avoid this consequence, and further in accordance with the invention, the closure may be provided with an extension overlying the lid in opposed relation to the aforementioned tab portion, and the heat seal may include both an annulus surrounding the aperture as described above and a further seal portion bonding the extension to the lid such that the peel force required to separate the extension from the lid is greater than that required to separate the closure member from the lid at the annulus, the aperture being easily opened by peeling back the closure member from the flange while the closure member remains secured to the lid by the further seal portion. This promotes retention of the closure member on the lid, as desired for environmental reasons. Moreover, the peeled but retained metal foil closure member can be folded over the aperture to provide a measure of coverage and protection for the contents of a can which has been only partially emptied.

[0022] Additionally, a body of fragrance-providing material may be disposed between the closure member and the lid and surrounded by the heat seal such that when the closure member is subjected to a peel force effective to open the aperture, the body of fragrance-providing material becomes exposed. The fragrance thereby released, in proximate relation to the nostrils of a person drinking from the can, enhances the effective flavor sensed by the drinker.

[0023] The can body may be a drawn and ironed metal can body for holding a carbonated beverage. The lid may be formed with a peripheral rim engaging the open upper end of the can body and projecting upwardly above the upper surface of the lid, the body being formed with an outwardly concave lower end, and the rim and body lower end being mutually shaped and dimensioned to permit stable vertical stacking of the can with other identically shaped and dimensioned cans. In such a structure, although the flexible closure member (bulging because of the internal pressure) is domed so as to rise to a height above the annular flange, the height of the rim, the concavity of the body lower end, and the height to which the closure rises above the annular flange are such that there is sufficient clearance between the lid upper surface of the can and the concave bottom of another identical can stacked above it to accommodate the domed closure.

[0024] Metal foil as used for the closure (e.g. as a lacquered foil or as part of a foil-polymer laminate) has the advantage of affording excellent gas barrier properties, so

that the shelf life and quality of the product are comparable to that which is obtained with a normal can, or a glass bottle, and superior to most other beverage container systems (including PET bottles and other polymer containers). Aluminum foil, for instance, is an effectively perfect barrier for oxygen (important for beer to prevent development of off-flavors owing to oxidation) and for carbon dioxide (important where carbonation levels need to be maintained). It is also an effective barrier to prevent migration and loss of fragrance and flavor components.

[0025] The aperture defined by the flange preferably extends over a minor fraction of the area of the open end of the can body. Especially for holding contents such as carbonated beverages, in cans wherein the open end of the can body has a center of symmetry (e.g. being circular), the annular flange and the aperture are disposed eccentrically of the can body open end so as to be relatively close to the periphery of the lid, for ease of pouring or drinking. That is to say, the flange is disposed in a portion of the lid eccentric to the geometric axis of the can, i.e., close to a side of the can.

[0026] Although the shape of the aperture can take different forms, noncircular apertures are nonpreferred, and, in particular, angular apertures or aperture shapes with very small radii of curvature are not suitable for the present invention. If, instead of a circular aperture, an elliptical or irregularly shaped aperture is provided, e.g. having an aspect ratio between about 1.1 and 1.5, the flange (even if straight-sided) is not strictly frustoconical; it will be understood that the term "frustoconical" is used broadly herein to define an upwardly convergently sloping straight-sided flange continuously surrounding an aperture, whether the aperture is circular or not.

[0027] In further aspects, the invention embraces a can lid member as described above, mountable on a metal can body having an open upper end so as to be peripherally secured to and to close the can body end; the combination of this lid member with a flexible closure member extending entirely over the aperture and peelably bonded to the flange outer surface around the aperture; a carbonated or otherwise pressurized beverage package comprising a can as described above in combination with a body of a pressurized beverage contained within the can; and a method of producing a can containing a pressurized beverage, comprising filling a drawn and ironed metal can body, having an open upper end, with a pressurized beverage, and closing the open upper end of the can body by peripherally securing thereto a metal can lid member as described above having a flexible closure member extending entirely over the aperture defined by its annular flange and peelably bonded to the flange outer surface around the aperture.

[0028] In the can of the invention, the provision of the upwardly projecting annular flange defining the can aperture, and the securing of the flexible closure member by peelable bonding to the upwardly sloping outer surface of this flange, enable the use of a peelably bonded closure member on an otherwise conventional carbonated beverage can, despite the high differential pressure (positive internal pressure) acting on the closure through the aperture and the resultant outward bulging or doming of the flexible closure member. This is because the angle of slope of the flange can be made steep enough so that a line tangent to the arc of

curvature of the domed closure member at the inner edge of the flange lies at an angle (to the plane of the flange inner edge) which is not substantially greater than, and is preferably less than, the angle of slope of the flange outer surface. In such case, the internal pressure acting on the closure member does not exert any significant component of peeling force that would tend to separate the closure member from the flange by peeling. Instead, the forces acting on the peelably bonded flange area owing to tension in the closure member are predominantly shear in character. Heat seal bonds, for instance, are strong under shear loading, especially at ambient temperature; the inability of conventional heat sealed closures to withstand internal pressure in carbonated beverage cans has been caused by the substantial peeling forces exerted on such closures when the closures bulge, under the elevated pressure within a can of carbonated beverage, at a substantial angle to a planar horizontal flange surrounding an aperture.

[0029] For a given internal pressure condition, aperture dimension, and closure member, the minimization or elimination of peeling force exerted on a closure bond by elevated pressure within the can is dependent on the angle of slope of the flange. Stated generally, the greater the angle of slope, the easier it is to provide a bonded closure that will not burst from internal pressure yet can be easily manually peeled by a consumer, having regard to the extent of doming of practicable flexible foil closure members under the pressures within a carbonated beverage can. With the flat lid surface and upwardly projecting frustoconical flange of the present invention, any desired angle of slope can readily be provided, in contrast to the range of angles permitted by other geometries such as a uniformly spherically domed lid having an aperture therein. Moreover, the arrangement of flange, aperture, and domed closure of the invention, occupying only a portion of the area of the can end, enables the height of the closure to be restricted to an extent compatible with convenient vertical stacking of cans.

[0030] The use of a can end or lid having an aperture with a peelable heat-sealed closure, in accordance with the present invention as described above, affords additional advantages in that the strength and/or the size of the lid may be reduced (without decreasing the desired size of the aperture for pouring or drinking), as compared to a conventional can lid having a riveted tab and scored area. This is because the strength and size requirements imposed on the lid by the riveted tab and scoring are eliminated. In addition, the forming operations for the flange and aperture of the present invention are less demanding than for a riveted tab, the most critical being the formation of the reverse bead curl, in embodiments of the invention including that feature.

[0031] Reduction in strength requirements enables use of a less expensive alloy for the lid than the AA5182 currently used, and/or a reduction in lid gauge, thereby affording savings in metal cost. For example, in particular embodiments of the invention, the lid may be fabricated of an alloy similar in composition to AA5182, but with a reduced concentration of magnesium. Alternatively, AA3104 or 3004 alloys, which are the alloys most commonly used for the can body, could be used. In each case, the gauge of the sheet would be selected to provide the desired property combination. For the case of AA3104 alloy, the can end and can body would be the same alloy and this is advantageous in several respects. For example, the recycling of used beverage cans

(UBCs) benefits from the reduced magnesium oxide dross formation. Furthermore, there are benefits to be gained during metal processing. For example, since only one alloy is used for the can end and can body, the casting and rolling scheduling can be greatly simplified and rolling mill schedules can be optimized for a single alloy, allowing improvements in mill productivity. Similarly, it should be possible to reduce metal inventories. Alternatively, the lid may be made of other metals, such as steel, that are unsuitable for a riveted tab and scored area opening system.

[0032] Reduction in size requirements, a result of the elimination of the need to accommodate the riveted tab at a central location on the lid while also affording adequate area for a pouring/drinking opening of preferred large size, further reduces strength requirements. Whereas a lid diameter of about $2\frac{1}{8}$ inches represents a currently practicable lower limit for a can with a riveted tab and a scored area providing a desirably large opening, with the present invention the lid diameter can advantageously be reduced to less than 2 inches, indeed substantially less, yet without reducing the size of the pouring/drinking aperture. Since a reduced lid size will have a reduced tendency to buckle when pressurized, the gauge of metal used can be reduced by at least about 5% below the current value of 0.0086 inch ($\approx 218\mu$) used with $2\frac{1}{8}$ inch diameter AA5182 alloy lids. Alternatively, the design of the lid can be modified to eliminate the countersink recess which is conventionally formed in the peripheral area of can lids to prevent stiffening and thereby to prevent excessive deflection and buckling. In yet a further alternative, the reduced tendency of a smaller diameter lid to buckle can be exploited by using a lower strength alloy than AA5182, with the advantages in cost and recycling mentioned above.

[0033] The reduction in lid size attainable with the invention requires a reduction in diameter, or formation of a neck, in the upper portion of the can body on which the lid is mounted, so as to conform to the small lid diameter without detracting from the fluid capacity of the can. To this end, the upper part of the sidewall of a conventional drawn and ironed can body may be subjected to one or more neck-forming operations that reduce the upper body diameter to conform to the lid. Alternatively, the drawing and ironing operation may be modified so as to form the necked portion from the bottom portion of the can body (which is of higher gauge than the sidewall), forming an open end for the neck, and closing the other end of the can body (which, in this embodiment, is the lower end) by seaming a plain can end thereto before filling. The reduced diameter lid with the flanged aperture and heat-sealed closure is then seamed onto the open neck after the can is filled.

[0034] More generally, in the cans and lids of the invention the countersink may be reduced or eliminated even if the lid is of conventional diameter, owing to the stiffening effect of the annular flange, in combination with a suitable choice of alloy and gauge; additional stiffening features such as ribs, coined regions and/or raised or depressed panel areas may also be formed in the lid when the countersink is reduced or omitted.

[0035] Further features and advantages of the invention will be apparent from the detailed disclosure hereinbelow set forth, together with the accompanying drawings.

BRIEF DESCRIPTION OF THE DRAWINGS

[0036] **FIG. 1** is a perspective view of a can embodying the present invention in a particular form;

[0037] **FIG. 2A** is an enlarged and somewhat simplified fragmentary elevational sectional view of a portion of the lid member of the can of **FIG. 1**, including the aperture-defining flange and closure member;

[0038] **FIG. 2B** is a highly simplified and schematic representation of the same view as **FIG. 2A**;

[0039] **FIG. 3** is a view similar to **FIG. 2A** of a flexible closure member bonded to a conventional planar flange defining an aperture;

[0040] **FIG. 4** is a fragmentary view similar to **FIG. 3** of a portion of the flange and closure member of the embodiment of the invention shown in **FIGS. 2A and 2B**;

[0041] **FIG. 5** is a simplified and somewhat schematic top plan view of the can of **FIG. 1**;

[0042] **FIG. 6** is an exploded diagrammatic elevational sectional view of the can lid and closure member of **FIG. 5**;

[0043] **FIG. 7** is a plan view of the closure member of **FIG. 5**;

[0044] **FIG. 8** is a side elevational view, partly broken away, of two cans having the structure shown in **FIG. 1**, illustrating the ability of the cans to be stacked vertically;

[0045] **FIG. 9** is a view similar to **FIG. 2B** illustrating a condition of excessive bulging of the closure member;

[0046] **FIG. 10** is a graph representing the relationship between sealing temperature and peel strength in Example 2 described below;

[0047] **FIG. 11** is a graph representing the relationship between heat seal temperature and burst pressure in the same example;

[0048] **FIG. 12** is an enlarged fragmentary sectional elevational view of a portion of a lid member embodying the present invention;

[0049] **FIG. 13** is a schematic fragmentary sectional elevational view of a lid member embodying the invention;

[0050] **FIG. 14** is a graph showing bulge height of an exemplary closure member as a function of pressure within the can (i.e., differential pressure Δp);

[0051] **FIG. 15** is a schematic plan view of a can lid embodying the invention and having a "stay-on" closure member;

[0052] **FIG. 16** is a graph showing 90° peel force as a function of displacement of the closure member of **FIG. 15**;

[0053] **FIGS. 17A and 17B** are highly schematic fragmentary elevational sectional views in illustration of a further embodiment of the invention including a fragrance reservoir;

[0054] **FIG. 18** is a sectional elevational view of one form of can lid embodying the invention and including a fragrance reservoir;

[0055] **FIGS. 19 and 20** are views similar to **FIG. 15** of two can lids embodying the invention and including both a stay-on closure member and a fragrance reservoir;

[0056] **FIG. 21** is a sectional view of another form of can lid embodying the invention, in which the conventional countersink is omitted;

[0057] **FIG. 22** is an elevational view of a further embodiment of the can of the invention, having a reduced-diameter body neck and lid;

[0058] **FIG. 23** is an enlarged fragmentary perspective view of the upper portion of the can of **FIG. 22**, showing the lid with the heat-sealed closure member in place;

[0059] **FIG. 24** is a view similar to **FIG. 23** with the closure member removed;

[0060] **FIG. 25** is an elevational view of another embodiment of the can of the invention;

[0061] **FIG. 26** (prior art) is an exploded and highly schematic sectional view in illustration of a system for producing a conventional drawn and ironed can body;

[0062] **FIG. 27** is a fragmentary view, similar to **FIG. 26**, of one form of modification of the system of **FIG. 26** for producing the body of the can of **FIG. 25**;

[0063] **FIG. 28** is an elevational view of the can body as formed by the system of **FIG. 27**;

[0064] **FIG. 29** is a view similar to **FIG. 27** of an alternative modification of the system of **FIG. 26** for producing the body of the can of **FIG. 25**;

[0065] **FIGS. 30A, 30B and 30C** are simplified fragmentary elevational sectional views of can lids in accordance with the invention respectively having a conventional countersink, a countersink of reduced dimensions, and no countersink;

[0066] **FIGS. 31A, 31B, 31C, 31D and 31E** are simplified and greatly enlarged fragmentary perspective views of types of stiffening features that may be formed in a can lid;

[0067] **FIGS. 32A and 32B** are, respectively, a plan view and an elevational sectional view of a can lid, embodying the invention and omitting a countersink, with added stiffening features;

[0068] **FIGS. 33A and 33B** are, respectively, a plan view and an elevational sectional view of another can lid, embodying the invention and omitting a countersink, with added stiffening features; and

[0069] **FIGS. 34A and 34B** are, respectively, a plan view and an elevational sectional view of yet another can lid, embodying the invention and omitting a countersink, with added stiffening features.

DETAILED DESCRIPTION

[0070] The container of the invention will be described, with reference to the drawings, as embodied in a metal can **10** for holding a carbonated beverage such as soda or beer. The can **10** includes a one-piece can body **11** constituting the bottom **12** and continuous, upright, axially elongated, generally cylindrical side wall **14** of the can, and a lid **16** which, after the can has been filled with the beverage, is peripher-

ally secured to the open top end of the can body to provide a complete, liquid-tight container.

[0071] In this embodiment, the body **11** may be an entirely conventional drawn-and-ironed aluminum alloy can body, identical in structure, alloy composition, method of fabrication, configuration, gauge, dimensions and surface coatings to can bodies currently commercially used for carbonated and other beverages (alternatively, for example, the body may be a steel can body, such as are in common use in Europe). In particular, and in common with known can bodies, the bottom **12** of the body **11** is externally concave and the open top end of the body has a circular edge **18** lying in a plane perpendicular to the vertical geometric axis of the side wall **14**. The terms "aluminum" and "aluminum alloy" are used interchangeably herein to designate aluminum metal and aluminum-based alloys.

[0072] Except as hereinafter described, the lid **16** may also be a generally conventional aluminum alloy lid member of the type currently commercially used for beverage cans having drawn and ironed one-piece can bodies such as the body **11**. Thus, the alloy of which it is constituted, the steps and procedures employed in its fabrication (with the exceptions noted below), and its general overall configuration, dimensions, gauge and surface coatings as well as the manner in which it is secured to the top edge **18** of the can body **11**, may all be the same as in the case of present day can lids well-known in the art.

[0073] It should be noted, however, that since the can lid of the present invention is not subjected to the rivet-forming and scoring operations that must be performed on currently conventional can lids, since the strength and rigidity necessary for the conventional rivet and tab area to withstand the lever action are not required, and since gauge and strength requirements related to the presence of a score line do not apply, the invention permits the use of nonconventional can lid alloys, materials and/or lid gauges. For example, coated steel can lids, which are normally too difficult to open by the conventional scoring mechanisms, could be used in the practice of the invention. The current gauge used for AA 5182 alloy lids could be reduced and/or the alloy composition could be modified by reducing the proportion of Mg, thereby lowering costs. Similarly, AA 5182 alloy could be replaced as the alloy of the lid with a lower cost, lower strength alloy such as AA 3104 alloy or AA3004 alloy, commonly used for can bodies (but not, heretofore, for can lids). Used at an appropriate gauge, AA 3104 alloy or AA 3004 alloy may have sufficient strength for the lid structure of the present invention; it could offer the advantages of lower cost as compared to the AA 5182 alloy currently used for can lids and would also afford benefits for recycling, in that the can lid and body would be made of the same alloy.

[0074] In particular, the lid **16** in this illustrated embodiment is substantially rigid, and has a substantially flat upper surface **20** with a circular periphery, around which is formed a raised annular rim **22** projecting upwardly above the plane of the flat upper surface **20**. When the lid is mounted on the open upper end of a beverage-filled can body, in known manner, the rim **22** engages the upper edge **18** of the can body; the circular flat surface **20** lies substantially in a horizontal plane, perpendicular to the vertical geometric axis of the cylindrical side wall **14**, and is centered with respect to the latter axis.

[0075] The lower end **14a** of the side wall **14** of the can **10** is shaped (tapered) to interfit with the rim **22** of the lid of another identical can **10a**, when the can **10** is stacked vertically on top of the can **10a** as shown in FIG. 8. A multiplicity of the cans may thus be stably vertically stacked, one on another, as is true of present-day conventional cans of the same general type. The elevation of the lid rim **22** above the flat upper surface **20** of the lid, together with the concavity of the can bottom **14**, cooperatively define a central gap or space between the lid of one can and the bottom of the next can above it, in such a stacked arrangement.

[0076] Also in common with present-day conventional lid members used with one-piece drawn-and-ironed aluminum alloy beverage can bodies, the lid **16**, when secured to the beverage-filled can body, provides therewith a complete sealed enclosure holding the beverage. The lid is thus subjected to elevated internal pressure within the can (i.e., pressure higher than ambient atmospheric pressure) if the beverage is carbonated. However, the formed aluminum alloy lid is substantially rigid, so that it undergoes at most only a small deflection of its upper surface as a result of this pressure condition, and the upper surface **20** remains substantially flat notwithstanding the internal pressure acting on the lid.

[0077] The lid **16** is arranged to provide an aperture through which the beverage contained in the can may be poured or removed by drinking directly from the can, either with a straw inserted through the aperture or by juxtaposition of the consumer's mouth to the aperture. Heretofore, in cans for holding carbonated beverages or other such contents at elevated pressure, the aperture-providing feature has conventionally included a scored portion of the metal of the lid member and a riveted pull tab system for parting the lid metal along the score line to open the aperture.

[0078] The present invention, in contrast, provides a pre-formed open aperture **24** in the lid, and a peelable, flexible closure member **28** covering the aperture. In order to achieve adequate burst resistance without requiring excessive force to peel the closure member, a shallow upwardly projecting annular flange **30** is formed in the lid within the area of the flat upper surface **20**, to surround and define the aperture **24** and to provide a seat for the closure member. For purposes of illustration, the flange **30** and its counterparts in other embodiments of the invention hereinbelow described are shown as frustoconical (i.e., having straight-sided upwardly sloping outer surfaces), but it is to be understood that the upwardly sloping outer surface of such a flange, in cans and lids of the present invention, may alternatively be a curved sloping surface.

[0079] More particularly, the flange **30** projects upwardly from the upper surface **20** of the lid, and has an upwardly sloping outer flange surface **32** and an annular inner edge **34** defining the aperture **24**, which is illustrated as being of circular configuration but is not limited to a circular shape. The inner edge **34**, as shown in FIGS. 2A and 2B, is preferably formed as a bead **36** with a reverse curl, which is tangent to a horizontal plane represented by line P (FIGS. 2A and 2B) and to the line of slope of the outer flange surface **32** so that, once the closure member **28** is heat-sealed to the flange surface, the cut metal (typically an aluminum alloy) at edge **34** cannot come into contact with the con-

tained beverage. This is advantageous because the cut metal at the edge (unlike the major surfaces of the lid) has no protective coating, and would be attacked by acidic or salt-containing beverages if it were exposed thereto. The reverse curl of bead **36** also prevents a drinker's lips from touching and being injured by the cut metal at edge **34**, and avoids any possibility of damage to the closure member by contact with the cut metal. However, the invention may also be embodied in a can wherein the aperture has a standard (not reverse) bead curl, which also affords such benefits as safety for the consumer, it being noted that where the cut edge of the metal is not kept from contact with the contained liquid by a reverse curl, it may be protected by application to the cut edge of a lacquer.

[0080] The flexible closure member **28** is constituted of a sheet material comprising metal foil, e.g. aluminum foil; in the described embodiment of the invention, the closure member is fabricated of a suitably lacquered aluminum foil sheet or an aluminum foil-polymer laminate sheet. Stated more broadly, materials that may be used for the closure member include, without limitation, lacquer coated foil (where the lacquer is a suitable heat seal formulation); extrusion coated foil (where the polymer is applied by a standard or other extrusion coating process); the aforementioned foil-polymer laminate, wherein the foil is laminated to a polymer film using an adhesive tie layer; and foil-paper-lacquer combinations such as have heretofore been used for some low-cost packaging applications.

[0081] The closure member extends entirely over the aperture **24** and is secured to the flange outer surface **32** by a heat seal extending at least throughout the area of an annulus entirely surrounding the aperture. Since the reverse curl bead **36** does not project beyond the slope of the flange outer surface, the closure member smoothly overlies this bead as well as the flange outer surface, affording good sealing contact between the closure member and the flange.

[0082] The closure member, in the described embodiment of the invention, is bonded by heat sealing to the flange **30**, covering and closing the aperture **24**, before the lid member **16** is secured to a can body **11** filled with a carbonated beverage. Once the lid has been mounted on the body to complete the enclosure of the beverage, elevated pressure generated by the beverage acts on the inner surface portion of closure member **28** which is exposed through the aperture to the interior of the can, causing the flexible closure member to bulge outwardly. Further in accordance with the invention, however, the angle θ (**FIG. 2A**) of slope of the flange outer surface relative to the plane of the annular edge **34** (i.e., plane P) is selected to be such that a line tangent to the arc of curvature of the bulged closure member at the inner edge of the flange lies at an angle to plane P not substantially greater than the angle θ of slope of the flange outer surface. As indicated in **FIG. 2B**, since the upper surface **20** of the lid member **16** is flat and horizontal (and thus parallel to plane P), θ may alternatively be defined as the angle of slope of the flange outer surface to the flat lid surface **20**.

[0083] Preferably the angle θ is between about 12.5° and about 40° to the plane P; a more preferred lower limit for θ is about 15° , and a more preferred upper limit is about 35° , or even in some instances about 30° . In currently particularly preferred embodiments, the angle θ of slope is between about 20° and about 35° to the plane P.

[0084] After initial forming of the flange there is some spring-back of the metal so that tooling with a 35° forming angle will result (after spring-back) in a flange angle of about 30° . Furthermore, when the can is pressurized, the can end bows and the effective flange angle is further reduced, by an amount which depends on the internal pressure but is typically a few degrees. For the burst resistance calculations discussed below, it is the actual angle of the flange when the can is pressurized that is relevant (i.e., after spring-back and the bowing of the can end are taken into account) and not the angle of the forming tool.

[0085] In **FIGS. 2A and 2B**, A is the diameter of the aperture **24** in plane P, R is the radius of curvature of the bulged or domed closure member **28**, and h is the maximum vertical height of the domed closure member above the aperture plane P. In these figures, the foil closure is shown domed to the point at which the flange is tangential to the arc of the domed foil closure member **28**, i.e., at which the line of slope of the flange surface **32** as seen in a vertical plane is tangent to the arc of curvature of the closure **28** (as seen in the same vertical plane) at the edge of aperture **24**.

[0086] For the closure configuration illustrated in **FIGS. 2A and 2B**, the forces acting on the heat sealed flange area due to the tension in the foil, are predominantly shear in character, with no significant peel force component. In this case, the burst resistance will depend on the shear strength of the heat seal joint or the bulge strength of the foil or foil laminate itself. This ensures that the burst resistance of the lid is enhanced significantly compared to that of a standard heat sealed container.

[0087] Heat seal bonds are strong under shear loading, especially at ambient temperature, and an annular heat seal about 2 mm-3 mm wide is sufficient to resist the anticipated shear forces which result from the internal pressure. If the foil is domed to a lesser extent than shown in **FIGS. 2A and 2B**, relative to the flange slope angle θ , the foil laminate will tend to hold down the heat seal bond with a corresponding additional enhancement of the burst resistance. If, however, the foil were domed to a greater extent than is shown in **FIGS. 2A and 2B**, relative to the flange slope angle, a peel force component would arise at the inner edge of the aperture, with an increased likelihood of burst failure.

[0088] The frustoconical aperture-defining flange enables provision of a flange slope angle θ sufficient to accommodate the extent of doming or bulging of the closure member to be used therewith, under the elevated internal pressures for which the can is designed, and thereby enables the burst resistance to be enhanced significantly, for a closure with a peel force which is acceptable to the consumer. The peel force is dependent both on the inherent peel properties of the selected heat seal lacquer system, and on geometric effects associated with the complex bending and distortion which the closure foil undergoes during peeling.

[0089] As will therefore be clear, the flange slope angle and the form of the foil closure strongly influence the burst resistance. In addition to the flange slope angle and extent of doming of the closure, not only the resistance of the heat seal bond to shear forces but also the strength of the foil of the closure member are selected to withstand the forces acting thereon. If the flange slope angle, in accordance with the invention, is such as to substantially avoid any substantial peel force component of forces acting on the heat sealed area

owing to tension in the foil from the internal pressure acting on the closure member, and if the heat seal bond and the shear resistance of the bond are adequate, burst failure could occur by failure of the foil itself. The shear force required to break the heat seal bond can be adjusted either by increasing the width of the heat sealed region, or by selecting laminates or coating formulations which achieve a higher shear strength. Both of these expedients, however, would increase the peel force required to open the container.

[0090] The effect of heat sealing the closure member 28 to a sloping flange surface rather than a horizontal flange surface, will be apparent from a comparison of FIGS. 3 and 4. FIG. 3 represents an aperture 40 in a conventional lid member 41 wherein the flange 42 around the aperture is simply a flat horizontal portion of the lid upper surface, coplanar with the aperture edge 43. A flexible closure member 44 covering the aperture 40 and bonded by heat sealing to the coplanar flange 42 will bulge, in the same manner as the closure member 28 in FIG. 2A, if the lid member 41 is mounted on a can body filled with a carbonated beverage or other pressure-generating contents. Assuming that equal elevated pressures exist within the cans of FIGS. 2A and 3, that the diameters of apertures 24 and 40 are equal, and that the same flexible sheet material is used for the closure members 28 and 44, the extent of bulging of the closure members (defined by h and R) should be essentially identical in both cans. In the case of the planar flange of FIG. 3, the consequent tension force F_T acting on the heat-seal-bonded portion of the closure member 44 at the edge of the aperture 40 will have a substantial peeling force component F_p acting at 90° to the plane of the flange surface. In the case of the sloping flange of the invention, however, as shown in FIG. 4, owing to the above-described relation of angle θ to the angle of the tangent to the arc of curvature of the domed closure member 28 at the aperture edge 34 (in which, in FIG. 4, the reverse curl is omitted for simplicity of illustration), the same tension force F_T (which acts in the direction of the aforementioned tangent at the edge of the aperture) has no significant peeling force component F_p acting in direction D at 90° to the plane of the (sloping) flange surface 32.

[0091] Under the pressures that may obtain within a can of carbonated beverage, the peeling force component F_p acting on a flange that is coplanar with the aperture edge can be sufficient to cause the closure member to progressively separate from the flange by peeling until it bursts open, at least if the strength of the heat seal bond is within conventional limits as desired for ease of peeling by a user. The sloping of the flange prevents this from happening, and thereby increases the burst resistance of the heat-sealed closure member sufficiently to enable its safe use on a carbonated beverage can without having to increase the heat seal bond strength to a point which would make the closure member difficult to remove by a user.

[0092] It will be understood that the extent of bulging of the closure member under the influence of pressure within the can, and thus the angle of the tangent (relative to plane P) to the bulged or domed closure member at the aperture edge, is dependent on the pressure within the can and the elastic deformability of the closure member. Desirably, the slope angle θ of the flange surface 32 should be chosen to be sufficiently large so as to be compatible with the bulging characteristic of the chosen closure member material. The

provision of the flange, which serves as a seat for the heat sealing of the closure member, as a frustoconical projection from a (preferably substantially flat) upper surface of a substantially rigid lid, facilitates this provision of a relatively large slope angle. At the same time, by making the aperture area a minor fraction of the total area of the can open end, the height h of the domed closure may readily be kept sufficiently small to be accommodated between the lid of one can and the concave bottom of another when the cans are stacked vertically as shown in FIG. 8.

[0093] Further, it will be understood that the benefits of the invention may be realized even if the flexible closure member bulges slightly beyond the ideal limit of tangency to the slope of the flange. In such a case, the peel component of force will start to grow, but may still be insufficient to cause failure of the bond.

[0094] FIGS. 5-7 illustrate further the configuration and arrangement of the flange, aperture and closure member at the top of the can in the embodiment of FIG. 1. With a circular can lid member 16 having a diameter of 48 mm, mountable on a can body having a correspondingly dimensioned circular open upper end, a circular aperture 24 having a diameter of 20 mm is defined by a frustoconical annular flange 30 having a maximum diameter (in the plane of lid surface 20) of 30 mm. As best seen in FIG. 7, the foil-polymer laminate closure member 28 has a circular central portion 32 mm in diameter (large enough to completely overlie the sloping outer surface of the flange), with a short projection 28a on one side for overlying part of the flat upper surface of the lid and an integral tab portion 28b on the opposite side which, outwardly of the flange 30, is not heat sealed but is free to be bent and pulled. The exploded diagrammatic elevational view of FIG. 6 indicates the relative positions of the can lid 16 and the closure member 28, as well as the folding of the tab. The closure member is subjected to a preliminary forming step to impart a frustoconical shape (also indicated in FIG. 6) to its circular central portion for proper seating on and sealing to the flange 30.

[0095] The aperture 24 is shown in FIG. 5 as being disposed eccentrically of the geometric center (center of symmetry) of the can lid 16, i.e., relatively close to the edge of the lid, so that a user can easily bring the aperture to his or her mouth for drinking the contained beverage directly from the can. However, depending on use and contents, different positions for the aperture may be employed. Also, if desired, aperture configurations other than the circular shape shown may be provided.

[0096] The manufacture of the can of the invention, including particularly the lid and closure, may (as stated) be in many respects generally conventional. However, certain modifications of conventional practice and equipment, now to be described, are employed to achieve the novel flange shape and the heat sealing of the closure member thereto.

[0097] Illustratively, but without in any way limiting the invention thereto, the foil closure stock may be a suitable aluminum foil (e.g. made of alloy AA3104 or of a conventional foil alloy such as AA3003, 8011, 8111, 1100, 1200) with a foil gauge of 0.002"-0.004" ($\approx 50\mu$ to 100μ) which is either lacquered on one side with a suitable heat sealable lacquer, or laminated on one side with a suitable heat sealable polymer film (e.g., polyethylene, polypropylene, etc.), 0.001"-0.002" ($\approx 25\mu$ to 50μ) thick. The other (out-

wardly exposed) side should have a suitable protective lacquer coating. It may be desirable to print onto the foil using rotogravure, flexographic or another known printing method. It may also be desirable to emboss the laminate, or just the pull tab portion thereof, to provide an attractive surface texture which enhances the appearance of the closure and assists in opening by making the closure easier to grip.

[0098] In order to seal to the aperture, the closure members **28** with their described integral pull tabs are formed and stamped out from the foil laminate stock using a suitable press (standard presses can be used with tooling specifically designed for these closure members). In the embodiment where the frustoconical flange is preformed, the foil closure members are preshaped (by a drawing process) so that they will fit over the raised aperture of the lid.

[0099] A heat sealing machine with suitable tooling is used to heat seal the closures to the can lid. In the case where the frustoconical flange is preformed, the heat seal tooling is designed to conform to the flange shape. That is to say, the tooling is angled to match the flange (and the formed closure member). The exact heat sealing conditions are dependent on the polymer and heat seal coating formulation used. The temperature of the bottom heat sealing tool should be selected so that the coating on the inside of the lid member should not be significantly softened or melted during the heat sealing operation. For the commonly used can end coatings and for heat seal dwell times of about 0.3 sec. or less, the temperature should be less than about 220° C. and preferably about 200° C. or below. The upper tool temperature is set to ensure that the heat seal bond is achieved in an acceptably short time. Typical commercial heat sealing machines have dwell times of 0.3 sec. The dwell time, pressure and temperatures may be optimized for the particular heat seal application. Heat sealing the closure to the lid involves use of a customized heat sealing line (such as those built by Hans Rychiger AG, Steffisburg, Switzerland), with appropriately constructed heat seal tooling provided to bond the closure to the angled aperture.

[0100] The forming of the can lid member **16** itself with the frustoconical flange **30** and aperture **24** as described is relatively straightforward, using modified can end forming tooling, with provision for forming the reverse curl bead **36**. The can lids of the invention do not require the formation of a rivet or tab.

[0101] The lids, complete with heat sealed closures, are substantially compatible with existing can filling lines and will be a direct replacement for the currently commercially used lids for cans for carbonated beverages and the like. Modifications may be made in the lid handling equipment to minimize or eliminate the possibility of damaging the raised aperture and closure.

[0102] Alternatively, in the currently preferred method of fabrication, the can lid may initially be provided with the aperture **28** and reverse curl bead **36** around the edge thereof, and the closure member **28** may be heat sealed to the upper surface of the lid in covering relation to the aperture, before the upwardly sloping frustoconical configuration is imparted to the flange portion of the lid immediately surrounding the aperture. Forming of the frustoconical flange **30** then proceeds, with concomitant deformation of the

already heat sealed foil closure member, followed by mounting of the lid on a can body already filled with carbonated beverage.

[0103] As initially applied to the can lid, the portion of the closure member **28** extending across the aperture may be substantially planar as indicated at **28c** in **FIG. 12**, which shows a frustoconical flange **30** having an angle of slope θ of 23°. When the lid is mounted on a can body filled with a carbonated beverage, so as to completely enclose the beverage, the resultant pressure within the can creates a positive differential pressure Δp causing the deformable closure member to bulge upwardly. **FIG. 13** illustrates the location of the heat seal annulus **46** on the sloping outer surface of the frustoconical flange **30**.

[0104] A particular feature of the present invention is the dimension of the aperture **24**. There is a consumer preference for cans with good pouring characteristics (good pour rate with a smooth, streamlined flow). Cans with large opening ends (LOEs) have been introduced in recent years and have been successful, especially for beverages with lower carbonation levels (e.g. lemonade and iced tea), although in the case of highly carbonated beverages, problems with score line failure and burst resistance have been encountered. A conventional shape of apertures for beverage cans is approximately oval with an aspect ratio between about 1.1 and about 1.5. A standard aperture is 0.7 inch in diameter and an LOE is 1 inch×0.7 inch; thus, the current aperture size for a carbonated beverage container, expressed as average diameter, is from about 0.7 inch to about 0.875 inch.

[0105] Some can designs have also provided a separate vent hole in the lid to improve pouring and drinking characteristics, but the inclusion of the vent hole adds to manufacturing cost and may complicate the opening process for the consumer.

[0106] The aperture size and shape are important in determining pouring and drinking characteristics. In general, larger aperture sizes give better flow rates with a more even flow. The relation between aperture and flow rates is illustrated by the following test data obtained in experimental pouring tests with the can tilted from the upright position through an angle of 120°, so that the can walls make an angle of 30° to the horizontal, and oriented so that the aperture is at its lowest point on the can end:

TABLE 1

Aperture	Pour Rate (g./sec.)
Standard can aperture	56
LOE	70
0.5625" (14.3 mm), flat flange	18
0.625" (15.9 mm), flat flange	31
0.750" (19.0 mm), flat flange	50
0.875" (22.2 mm), flat flange	75
0.5625" (14.3 mm), angled flange	24
0.625" (15.9 mm), angled flange	35
0.750" (19.0 mm), angled flange	56
0.875" (22.2 mm), angled flange	93

[0107] In the above table, "angled flange" means an upwardly sloping frustoconical flange as provided in the present invention; "flat flange" means that the portion of the lid surrounding the aperture is substantially coplanar with the aperture edge, as in conventional can lids.

[0108] As will be apparent from Table 1, for equivalent hole sizes, the pour rate for “angled flange” apertures is higher by about 10 to 15% at a 30° tilt than that for “flat flange” apertures. The 0.750" angled flange aperture has a pouring rate at 30° tilt approximately the same as that of the current standard can aperture. The 0.5625" aperture (with both flat and angled flanges) has a significantly lower pour rate than that of the current standard can aperture. The 0.875" angled flange aperture provides a higher pour rate than the LOE design (which, like the standard can, has a flat flange). For the aperture range of interest, the pour rate is approximately proportional to aperture area.

[0109] As hereinafter further explained, the tear/shear forces acting on the closure member and seal tend to increase with aperture size, so that the maximum aperture diameter is limited by the need to provide a can with adequately high burst pressure or burst resistance (i.e., the

and heat seal must be able to withstand) may range from less than (or about) 25 lb./in. to about (or even somewhat more than) 75 lb./in., a tear/shear resistance of about 75 lb./in. being currently preferred in many cases. Typical filling line pressures for carbonated beverages are between about 50 and about 60 psi, though for some beverages (sports drinks, lemonade, etc.), lower carbonation levels are used. However, in order to take account of extreme conditions (temperature, agitation, etc.) a minimum test burst pressure requirement of 90 psi is currently specified for many applications, and a burst resistance of 100 psi would be even more desirable.

[0112] Table 2 sets forth values calculated using relation (1) above for tear/shear force γ (lb./in.) for various aperture diameters A and flange slope angles θ at a differential pressure Δ_p of 100psi.

TABLE 2

θ°	A =	γ (lb./in.)						
		0.500"	0.625"	0.750"	0.875"	1.000"	1.125"	1.250"
2.5		286.6	358.2	429.9	501.5	573.1	644.8	716.4
5		143.4	179.3	215.1	251.0	286.8	322.7	358.6
7.5		95.8	119.7	143.6	167.6	191.5	215.5	239.4
10		72.0	90.0	108.0	126.0	144.0	162.0	180.0
12.5		57.8	72.2	86.6	101.1	115.5	129.9	144.4
15		48.3	60.4	72.4	84.5	96.6	108.7	120.7
17.5		41.6	52.0	62.4	72.7	83.1	93.5	103.9
20		36.5	45.7	54.8	64.0	73.1	82.2	91.4
22.5		32.7	40.8	49.0	57.2	65.3	73.5	81.7
25		29.6	37.0	44.4	51.8	59.2	66.5	73.9

pressure at which the closure member and seal rupture or fail). Therefore, the range of average aperture diameter in accordance with the present invention is between about 0.625 inch and about 1 inch, to afford satisfactory pour rates (without any separate vent hole) and at the same time to achieve high burst resistance without sacrifice of other characteristics such as peelability.

[0110] Another important characteristic, for attainment of adequately high burst resistance, is the tear/shear force imposed on the heat seal and closure member by a given differential pressure. The tear/shear force γ (lb./in.) is determined by the differential pressure Δ_p (psi), aperture diameter A (inches) and angle of slope θ of the frustoconical flange 30, in accordance with the relation

$$\gamma = \frac{A \cdot \Delta_p}{4 \sin \theta} \quad (1)$$

[0111] In particular instances, depending (for example) on the degree of carbonation of the contained beverage and the consequent magnitude of differential pressure that the can, closure and seal must be designed to withstand, the design value of tear/shear force resistance for a can in accordance with the invention (i.e., the value that the closure member

[0113] These are the minimum strength requirements (lb./in.) for the closure member and heat seal to withstand a pressure differential Δ_p of 100 psi without rupture or failure (bursting), for each specified combination of aperture diameter A and slope angle θ . As is apparent, for a given differential pressure, the tear/shear force strength requirement decreases with increasing flange angle and increases with increasing aperture diameter.

[0114] By way of illustration, an aperture diameter of 0.875 inch and a flange angle of about 22.5° would require a closure foil with a breaking strength in excess of 57.2 lb./in. and an equivalent minimum heat seal shear strength, for burst resistance of 100 psi.

[0115] Typical aluminum lidding foils of 0.003 inch thickness can withstand a tear force in excess of 75 lb./in. Practicable heat seals capable of withstanding a shear force of 75 lb./in. can also readily be provided, in configurations suitable for the heat seal 46. Therefore, combinations of A and θ in Table 2 for which the calculated value of γ is 75 lb./in. or less enable satisfactory and practicable attainment of a burst resistance of 100 psi in the can of the present invention.

[0116] As already stated, to avoid a peel component in the force exerted on the closure member and heat seal by the differential pressure Δ_p , the bulge height h of the closure member above the plane P of the aperture 24 should not exceed a value h_{\max} at which the slope of the flange 30 is

tangent to the arc of the bulging closure at the edge of the aperture. This upper limiting value h_{\max} (in inches) is, again, determined by the angle of slope θ of the flange and the aperture diameter A (in inches) of the aperture **24**; in the case of a circular aperture, such limiting value can be calculated using the relation

$$h_{\max} = \frac{A}{2} \left(\frac{1}{\sin\theta} - \frac{1}{\tan\theta} \right) \quad (2)$$

[0117] It will be seen that the maximum permitted bulge height, to achieve the described freedom from any peel component, increases with aperture diameter and also increases with flange angle.

[0118] The actual bulge height in a closure member **28** produced by a given differential pressure Δ_p is dependent on the properties of the closure foil related to deformation, i.e., the deformability of the foil, as well as on the aperture diameter. **FIG. 14** illustrates the relationship of bulge height h (here given in mm) to pressure Δ_p for a $\frac{7}{8}$ inch aperture diameter and an exemplary aluminum foil 100μ (0.004 inch) thick. The Figure has been corrected for the small initial displacement of the foil relative to the flange (i.e., the foil was not perfectly flat after the forming and springback). The measurements were made with a lid clamped into place in the "buckle-tester." The position of the center of the foil covered aperture was measured carefully (using a precision laser measurement device) and the pressure was gradually increased. Measurements were taken at intervals of 10 psi up to 80 psi and the displacement at each pressure was computed and plotted in **FIG. 14**.

[0119] Examples of the maximum permitted bulge height (inches) as defined above, calculated for a circular aperture using relation (2), for various combinations of A (in inches) and θ , are set forth in Table 3:

TABLE 3

A (in.)	$\theta^\circ =$	h_{\max} (in.)					
		17.5	20	22.5	25	27.5	30
0.625		0.048	0.055	0.062	0.069	0.076	0.084
0.750		0.058	0.066	0.075	0.083	0.092	0.100
0.875		0.067	0.077	0.087	0.097	0.107	0.117
1.000		0.077	0.088	0.099	0.111	0.122	0.134

[0120] For an aperture diameter of 0.875 inch with a flange slope angle of 22.50, the maximum bulge height should be 0.087 inch to avoid peel force components.

[0121] If the bulge height exceeds the critical value, **FIG. 14** can be used to determine the angle of the tangent to the arc of the bulging closure foil at the edge of the aperture. If the stress within the foil can be determined, the peel component of the stress can be estimated. Provided that this component is less than the measured peel stress for the closure material, failure by peeling will not occur. However, it is preferred that the lid parameters be chosen to ensure that the bulge height does not exceed the above-defined limiting value at least for differential pressures up to 90 psi, more preferably for differential pressures up to 100 psi.

[0122] Metal foils have comparatively good creep resistance over the range of temperatures that may be experienced in service, and therefore afford an important advantage over polymeric closure member materials with respect to creep susceptibility and consequent short shelf life. Since creep is dependent on applied stress, increasing the thickness of the closure material can reduce or eliminate creep. For aluminum foil closure members, a thickness between about 0.003 and about 0.004 inch (about 75-100 μ) is sufficient to virtually eliminate creep.

[0123] The performance of the bond between the closure membrane and the lid flange is dependent on the properties of the adhesive layer and on the design of the joint. The flange angle is designed to ensure that the forces between the closure membrane and the flange are predominantly shear in character under the fully pressurized conditions of use. However, the shear stress in the joint can be affected by the width of the heat seal; i.e., increasing the width of the bond spreads the load and thereby reduces the stress intensity.

[0124] It is desirable for the width of the heat seal to be less than about 0.118 inch (3 mm) and preferably about 0.079 inch (2 mm). If the width is increased above about 0.118 inch (3 mm), the peel force required to open the container will be increased. Furthermore, an increased heat seal (and flange) width would mean that the drinking aperture has to be located further from the container edge, detracting from the convenience of the consumer by making the container less comfortable and more inconvenient to drink from.

[0125] Experimentally, it is found that a 0.079 inch (2 mm) wide heat seal annulus for the foil closure performs well in the can of the invention (see Example 4 below). Fully pressurized cans (60-70 psi) have been stored at ambient temperature ($\approx 20^\circ$ C.) for several months, with no detectable sign of creep in either the foil or in the adhesive bond joint.

[0126] In containers for beverages and the like with manually peelable closures, the peel force required to open the container should preferably fall within the range between about 1.8 lb. and 4.5 lb. (8N and 20N), and still more preferably within the range between about 2.25 lb. and 3.6 lb. (10N and 16N) as measured by a 90° peel test. The peel force required is dependent on the peel strength of the bond and on the effective width of the seal during the peeling procedure. In the case of an angled flange, there will also be a geometrical factor, which will affect the final peel force required. The strength and gauge of the foil will also contribute to peel strength since the peel action requires the foil to be bent and deformed.

[0127] In the case of heat seal bonding, the peel strength is influenced by the particular lacquer formulations on the two mating surfaces, and on the heat sealing conditions which are used. For example, in one preferred embodiment, the outer can end panel surface has a thin vinyl lacquer coating (Valspar Unicoat, up to about 2μ thick) and the aluminum foil closure material has a vinyl based heat seal lacquer (Alcan Rorschach TH388, between about 5 and 8μ thick).

[0128] For this combination of coatings, the peel strength falls within an acceptable range for peelability. At the same time, provided the closure foil has sufficient strength, the heat seal bond can meet the requirements for shear strength.

[0129] Variations in peel strength can be obtained by changes to the heat sealing temperature, the heat sealing pressure and/or the dwell time for sealing.

[0130] In addition to the aforementioned vinyl based lacquer systems, various other combinations of can end lacquer and heat seal coatings have been found to be suitable for the present invention. These are exemplified, without limitation, as follows:

Can lid coating (exposed side)	Foil Closure coating
Epoxy coating (solvent based lacquer)	Polypropylene based heat sealed lacquer
Polypropylene (extrusion coated)	
Laminated polypropylene	Polypropylene formulation: extrusion coated
Polyester coated (e.g. extrusion coated)	Polyester compatible heat seal coating
	Polystyrene/polyester blend

[0131] It should be recognized that the combination of specific coating formulations on the can lid (exposed side) and on the foil closure material (product side) needs to be carefully selected to provide the desired combinations of peel strength and shear strength. Furthermore, the coatings must also provide adequate protection from any corrosive attack of the metal by the product. The coatings must also comply with applicable food/beverage contact regulations.

[0132] The coatings, at the thicknesses applied, must also be capable of maintaining integrity during the forming operations to which the components of the lid are subjected. In particular, the coating on the lid must survive the bead curl forming operation.

[0133] It is found that coating formulations based on the classes of coatings listed above are able to meet all of these requirements. As will be seen from the above list, at least one of the two coating formulations (and preferably both) have a thermoplastic polymer as a major component (e.g. vinyl, polypropylene, polystyrene, polyester) and heat sealing is the preferred method of attaching the closure.

[0134] It will also be noted that the adhesion between the lacquers/coatings and the metal surfaces is important and suitable cleaning and, optionally, pretreatment of the foil surface prior to coating is recommended.

[0135] As already stated, for the peelable closures of the present invention, it is desirable that the foil closure be relatively easy for the consumer to peel back from the pouring/drinking aperture. However, it is also desirable to design the closure in such a way that the consumer is discouraged from removing the closure foil completely, since it may then be discarded as litter. A preferred design of closure for this purpose is illustrated in FIG. 15, which shows a can lid 116 having a flat upper surface and an eccentrically disposed aperture 124 surrounded by an angled flange to which a foil closure member 128 is bonded by an annular portion 146a of a heat seal. On the side of the aperture adjacent the lid edge, the closure member has an integrally formed pull tab 128b (folded back over the aperture, with its unfolded position indicated at 128b'). The closure member also has an integral "stay-on" extension

128a positioned in opposed relation to tab 128b (with respect to the aperture) and overlying the flat upper surface of the lid. Extension 128a is bonded to the lid by a further heat seal portion 146c, which is so dimensioned as to require a substantially greater peeling force (for separating extension 128a from the lid) than that required by annular heat seal portion 146a (for separating the closure member from the angled flange around the aperture).

[0136] In other words, the closure member 128 of FIG. 15 includes a "stay-on" tab area or extension 128a which is sealed to the lid panel 116 by portion 146c of the heat seal that has a size and shape which requires a substantially higher peel force (greater resistance to peeling) than the annular seal portion 146a surrounding the aperture 124, thereby discouraging the consumer from completely removing the closure foil. As a result of this design, when the consumer peels open the closure, the peel will initially be within the targeted range for each opening, e.g. from about 2.25 lb. to 4.5 lb. (about 10-20N). Then as the aperture is completely opened, the peel force will fall to a very low value so that the consumer will sense that the opening is completed. If the consumer continues to pull the closure, the required peel force will rise rapidly to a value which exceeds the normally accepted easy peel range, i.e. to >5.5 lb. (about 25N). An example of the peel characteristics of a closure of this invention is given in FIG. 16.

[0137] This variation in peel force requirement can be achieved most readily by careful design of the seal region, in particular by appropriately selecting the dimensions of the heat seal portions 146a and 146c. In the case of a heat sealed closure, this is easily achieved by the design of the heat seal tooling. With a pressure sensitive adhesive, it would be more difficult and would require the adhesive to be printed onto the closure film in the desired pattern.

[0138] FIG. 16 is a graph showing a typical variation of peel force (90° peel test) as the closure is peeled open. As the peel is initiated, the force rapidly increases as the foil peels away from the region of the flange on the pull tab side 128b. As the foil is peeled from the remainder of the flange and opens the aperture, the peel force remains fairly constant, rising to a second maximum at the end of the aperture. At this point, the foil is not sealed to the lid, and the peel force falls quickly to a low value. At the start of the "stay-on" extension region, the peel force rises to a high value to discourage the consumer from completely removing the closure foil.

[0139] Further control of the peel force can be obtained by varying the heat sealing conditions in the different regions of the closure. For example, if the temperature of the heat seal in the stay-on extension region were increased, a high peel strength would result. It is also possible to use a different heat seal lacquer, with a higher inherent peel strength, in the "stay-on" extension region. Yet another method of increasing the peel force requirement in the "stay-on" tab region is by the use of one or more ridges or other profiled features (not shown). Such features would serve to increase the effective area of the seal and to provide a degree of mechanical keying for the closure.

[0140] As discussed above with reference to FIG. 15, the peel force varies as the closure is peeled back. The detailed variation of the peel force required can be adjusted and controlled by the various methods described. The variation

shown in **FIG. 16** corresponds to a desirable behavior for the consumer, in that the uniform peel force after an initial higher start force provides ease of opening for the container; the subsequent drop in peel force gives the consumer an indication (by feel) that the aperture is completely opened; and, finally, the rapid rise of the force due to the “stay-on” extension signals the consumer that the closure is intended to stay on and be folded back for drinking.

[0141] With an aluminum foil closure material, employing a “stay-on” arrangement as described, the closure can be easily folded down so that it does not significantly interfere with the drinking experience of the consumer. Furthermore, since the foil has good dead-fold characteristics (i.e. it does not exhibit any noticeable spring back), the closure can be folded back over the aperture if desired. Although this does not reseal the can, it would prevent the undesired ingress of dirt or insects into the beverage between drinks, and may also reduce the spillage if a can is accidentally tipped.

[0142] Yet another advantageous feature of the invention, in particular embodiments as illustrated in **FIGS. 17-20**, is the incorporation of a source of a fragrance or aroma in the can lid, so that peeling of the closure member to open the can also acts to expose a small quantity of an oil or wax based aroma concentrate, located on the lid in a position which is in close proximity to the nostrils of a person drinking from the can aperture. The aroma is selected to enhance or complement the taste of the beverage.

[0143] It is well known that the senses of smell and taste are closely related, and in particular that the sense of smell can significantly enhance the taste experience. Preservation or enhancement of a smell associated with a particular beverage, thereby improving the aroma of the product, may serve to increase the overall enjoyment of the product. Fragrances which may be thus provided may include (by way of nonlimiting illustration) lemon, orange, lime, mint, etc.

[0144] The aroma-enhancing feature may, for example, advantageously be incorporated in a can lid **116** having a “stay-on” foil closure member **128** as described above with reference to **FIGS. 15-16**. A small part of the lid area, initially covered by the foil closure member (**FIG. 17A**), is exposed upon peeling of the closure member (**FIG. 17B**), is modified so as to receive a small quantity **156** of an oil- or wax-based fragrance. This can be achieved by forming a small upwardly opening depression or reservoir **158** in the lid **116** (**FIG. 18**) and/or by forming a similar receptacle indentation (facing the lid; not shown) in the foil closure member itself.

[0145] The reservoir, and hence the supply of fragrance, are disposed on the side of the aperture **124** away from the edge of the lid so as to be close to the nostrils of a person drinking from the can. This location is between the aperture **124** and the stay-on heat seal portion **146c** and is thus covered by the closure extension **128a** when the closure member is sealed on the lid.

[0146] A wide variety of concentrated fragrances are readily available and, for the described use, the volume required is about one drop (less than 0.01 ml). Since the fragrance is sealed between the lid **116** and the closure member **128**, there is little if any loss of fragrance during storage, owing to the excellent barrier properties of aluminum.

[0147] When the foil closure member is peeled back (**FIG. 17B**) to open the can it exposes the fragrant oil **156**, releasing the aroma. As will be apparent from the drawings, the fragrance reservoir **158** is positioned on the can lid in close proximity to the nose of a person drinking straight from the can, to maximize the effectiveness of the aroma.

[0148] For use with a lid having a fragrance reservoir, the heat seal **146** securing the closure member **128** to the lid **116** is configured to fully surround the reservoir **158** containing the supply of fragrance. Two specific heat seal designs for this purpose are respectively shown in **FIGS. 19 and 20**. In **FIG. 19**, the heat seal area **146a** around the aperture **124** is contiguous with the heat seal area **146b** surrounding the fragrance reservoir or well **158** and the heat seal portion **146c** that secures the “stay on” extension **128a** of the closure member to the lid; the design is such that as the lid is peeled back from the aperture, there is a high probability that the fragrance-containing depression **158** in the lid will be partially or fully exposed and the fragrance will start to be released. In **FIG. 20**, the heat seal area **146d** surrounding the fragrance containing reservoir is isolated from the heat seal portions **146a** (around the aperture) and **146c** (bonding the stay-on closure member extension to the lid), but again, the action of peeling back the closure member results in partial or complete opening of the reservoir to release the fragrance. In the case of **FIG. 20**, by isolating the fragrance reservoir **158** from the main heat seal areas **146a** and **146c**, the probability of premature evaporation of the fragrance owing to heat input from the heat sealing tools is significantly reduced.

[0149] In brief summary, the present invention provides a novel can end with a safe and convenient aperture and a heat sealable foil closure, suitable for use with carbonated beverages or similar products. Among the benefits and advantages that may be achieved with the cans of the invention are the following:

[0150] improved sanitary characteristics, because no external exposed surface is introduced into the beverage, as occurs when present-day scored lids are opened with a riveted pull-tab system;

[0151] enhanced aesthetics, in that the peelable foil closure can be embossed and printed (inside and/or outside);

[0152] increased selection of aperture size and shape since, while there will be some limitations, a wider range of aperture sizes and shapes will be possible than is the case with present-day scored lids;

[0153] greater safety, in particular because the reverse curl of the aperture-defining bead eliminates sharp edges;

[0154] ease of opening, and concomitant consumer satisfaction, since marketing studies in the food industry indicate that consumers prefer easy-peel closures to the scored ends of present-day carbonated beverage cans as well as to the use of can openers;

[0155] ease of use, since a can with this end design has better pouring characteristics and may be easier to drink from directly.

[0156] Especially preferred embodiments of the invention are carbonated beverage cans with readily peelable closure

members characterized by a burst resistance of at least about 90 psi (or higher, e.g. 100 psi or above) and a shelf life of at least six months or more. The creep resistance and barrier properties of foil closures, together with the shear strength of heat seals, enable attainment of the desired extended shelf life.

[0157] Still further features and advantages of the invention reside in the provision of cans with lids having the above described angled flange aperture and heat sealed closure member, wherein the lid diameter (hence, also, the lid area) is smaller than that of present-day conventional cans with riveted tabs and scored areas for opening, yet without any reduction in the size of the opening for pouring and/or drinking.

[0158] In recent years, the diameter of the can end (lid) used for carbonated and noncarbonated beverages has been significantly reduced. Most recently the size has been reduced from "204" size (about 2¼ inches in diameter) to "202" size (about 2⅜ inches in diameter). This size reduction alone represents a significant potential saving to can makers and fillers. However, a number of additional benefits can also be realized as a result of this size reduction.

[0159] For example, it is well known that a reduced diameter lid is less susceptible to buckling under the internal pressure. This can be exploited in a number of ways (the choice or combination depending on economic, aesthetic and other (e.g., hygiene, recycling, etc.) considerations. Essentially, a reduced lid diameter enables the lid profile design, alloy, temper and gauge to be reconsidered.

[0160] Furthermore, the smaller size means that adequate buckle strength can be achieved with a thinner gauge. For "204" size ends, the typical gauge was about 0.009 inch and for "202" ends, the gauge requirement is about 0.0086 inch.

[0161] As mentioned above, AA 5182, the currently preferred lid alloy, is a premium alloy (due to the Mg content) and is costly and difficult to roll. Moreover, for can end (lid) applications, the sheet must be coated on both sides. For these reasons, there is a significant economic incentive for can makers to reduce the lid size and gauge as much as possible.

[0162] The trend for cans to have larger opening ends (LOE) means that, with conventional riveted tab lids, the opportunity for further reduction in end diameter is very limited, since the tab and the centrally positioned rivet require the lid to be of a certain minimum diameter.

[0163] By use of the angled flange aperture and heat sealed foil closure system of the present invention, the lid diameter can be significantly reduced (e.g. to below 2 inches in diameter), while still retaining a large pouring opening. The reduction in lid diameter also enables the gauge of the lid to be further reduced (or, alternatively, enables use of a lower strength and lower cost alloy), since buckle resistance is easier to achieve with a smaller diameter lid.

[0164] With this approach, it should be possible to reduce the can end diameter by at least 5% to the "200" size (about a 10% area reduction, compared to the current "202" size), with an additional reduction of about 5% in gauge (to a gauge of less than 0.0082 inch), while still meeting the target buckle resistance of the can lid. Thereby significant savings in metal may be achieved, although an extra necking

stage must be incorporated into the can body making operation to conform the upper end of the can body dimensionally to the reduced-diameter lid, adding an expense that would partially offset the cost savings.

[0165] The reduction in can lid diameter attainable with the invention also affords opportunities to reduce or eliminate the "countersink" feature of the can lid, which is advantageous, since the countersink (formed around the periphery of the lid) is prone to contamination by dust or debris. FIG. 21 illustrates a lid 160 embodying the invention and free of countersinking, i.e., having no peripheral countersink (such as is shown, for example, at 162 in each of FIGS. 12 and 18); the substantially planar upper surface 164 of the lid extends all the way to the raised annular rim 166. It will also be recognized that the reduction or elimination of the countersink feature also reduces the metal usage (by up to about 5%), providing further potential cost savings.

[0166] It should be noted that, where it is desired to be able to stack cans on each other, a smaller diameter lid may require some redesign of the can body. In previous can designs, the bottom profile has been designed to stack against the lid. However, as lid diameters have decreased, it is becoming more difficult to achieve this. With the current "202" size lid, the can bottom design has been modified to achieve this stackability. However, the narrowing of the base is approaching the point where the stability of the can (to tipping) is becoming a concern. If the lid is further reduced in size it may therefore be necessary to redesign the can base further to enable stable stacking.

[0167] FIGS. 22-24 illustrate a specific embodiment of the invention in a beverage can including a one-piece can body 170 with a narrow neck 172 and a reduced-diameter can end or lid 174 (which has an angled flange aperture 176 and foil bonded heat sealed closure 178) with no countersink or recess.

[0168] The domed bottom 180 and sidewall 182 of the body 170 are formed with the draw and iron procedure currently in widespread use. The can body sidewall is then necked as shown at 172 to a small diameter of approximately 1 to 1.5 inches, and flanged to enable attachment of the lid 174. After the can is filled, the small diameter lid with the peelable foil bonded closure 178 as described above is seamed to the open upper end of the necked can.

[0169] The main purpose of the countersink in current can lid designs is to minimize deflection and also to reduce the probability of buckling or reversal of the can end under internal pressure. In the embodiment of FIGS. 22-24, the lid has a small diameter, and therefore will not deflect as much as a larger diameter end would. For that reason, there is no need for a recess or countersink. Since there is no countersink or recess, can end failure will not involve buckling. The maximum internal pressure for the end will be determined by the strength and gauge of the can end and the foil closure material, the bonding strength between the foil and end, and the seam integrity. Hence the can end material can be made from much lower gauge metal than that (e.g. AA 5182) which is currently used. The alloy used could also be the same as that used for the can body, for instance, AA 3104 alloy.

[0170] The narrow neck 172 gives the can a bottle shape, which may be preferred by many consumers for aesthetic

reasons, especially if this shape is enhanced with graphics and/or embedded design elements (not shown).

[0171] Illustrative dimensions of the can of FIG. 22 include a maximum can body diameter (bottom portion) of 2.60 inches, a neck tapering upwardly to receive a lid having an outer diameter of 1.56 inches, and an aperture with a diameter of 0.75 inch, the overall height of the can being 6.50 inches.

[0172] Another exemplary embodiment of the invention in a necked can with a reduced diameter lid 188 having an angled flange aperture and heat sealed closure is shown in FIG. 25. The can comprises a body 190 with an integral neck 192. The base of the container consists of a panel 194 similar to a conventional can lid (but lacking any rivet, tab, scored area or other opening system) and is seamed onto the open lower end of the can body in the same way as conventionally utilized to join a lid to the upper end of a drawn and ironed can body.

[0173] The forming of the body 190 may be understood by reference to the can body maker tooling shown in FIG. 26 and the alternative modifications thereof respectively illustrated in FIGS. 27 and 29. FIG. 26 shows, in simplified schematic cross-section, a standard can body maker (known in the prior art) comprising a hollow mandrel 200 with a shaped end cap 202, a series of ironing rings 204a, 204b, 204c, and a "dome" 206. The dome and the shaped end of the mandrel are designed to generate the familiar outwardly concave can bottom dome profile. This can body making operation results in a significant thinning of the metal sidewalls due to the ironing process, but the thickness of the metal in the bottom of the can is not significantly reduced.

[0174] FIG. 27 shows one modification for producing the body of the can of FIG. 25. The features of particular significance are the dome tool 208 which is designed to generate the neck 192 of the new can body 190, and the end cap 210 of the mandrel 212 which is shaped so as to match the shape of the dome tool (allowing a suitable clearance).

[0175] The detailed shape of this tooling is optimized so as to control metal flow during the forming operation, and to minimize the likelihood of metal failure (tearoffs and the like). In particular, small radii of curvature are avoided and the extent of the deformation is kept to a minimum consistent with the requirements for a neck. The neck 192 itself is slightly tapered so that the finished body 190 can be easily removed from the mandrel 212. The can body 190, complete with neck 192, is shown in FIG. 28.

[0176] With this formed shape as a starting point, a number of additional steps are employed to produce the final can of FIG. 25. The additional steps include trimming or punching an opening in the upper end of the neck 192 to constitute an open upper end of the can body, on which the lid 188 is to be secured; trimming the other end 214 of the can to remove earing scrap; and attaching a plain metal can end shell 194 to the latter end by a seaming operation. The can body is then filled, for example with a carbonated beverage, and the lid 188 with its angled flange aperture and heat sealed closure member is secured to the open upper end of the neck 192.

[0177] In addition to this preferred method, two alternative processes for producing the modified can body will be described. In the first alternative, the can body 190 with

formed neck 192 is produced using a double action forming process shown schematically in FIG. 29. The features of particular significance are that the dome tool of FIG. 27 is replaced by a tool 220 which is designed to generate the neck of the new container (as before), and the end cap of the mandrel is replaced by an annular piece 222. In the center of this a second movable tool 224 is introduced so the complete configuration operates as a double action press tool, with the outer annular portion generating the outer profile of the neck region, and the inner tool applying an additional second forming step to form the neck of the can body. The press itself needs to be modified to give the appropriate "double action" operation (double action presses and forming operations are well known in, for example, the cup forming process). The additional steps for trimming, forming of the opening and application of the can bottom end and lid would be similar to those described in the preferred method.

[0178] The second alternative method (not illustrated in the drawings) involves the production of a modified can body with a convex domed end, by a standard drawing and ironing process and a subsequent hydroforming operation similar to that described by Belvac Production Machinery Inc., Lynchburg, Va., for shaping of can walls. This hydroforming process involves the use of a high pressure jet of fluid such as water and a shaped mold, to complete the forming of the neck region of the can. By using a split mold, the sidewall could optionally be shaped for decorative purposes.

[0179] It should be recognized that embodiments such as that of FIG. 25 may offer the following advantages:

[0180] The can body and neck are formed in a single high speed process and can utilize existing can body makers (with different tooling).

[0181] The neck is formed from metal which has not been thinned by the ironing process.

[0182] Although some re-tooling would be required, it should be relatively straightforward to modify filling lines to handle cans of this design, since they would be similar in shape to glass or PET bottles.

[0183] It will be recognized that this design and process will require changes to the tooling and container handling and inspection systems. However added costs due to these factors will, partly or completely, be offset by the savings listed above.

[0184] Although omission of the countersink from the lid has been described above for embodiments of the invention having lids of reduced diameter as compared to the conventional lid size represented by a 202 can, the invention more broadly contemplates the reduction or elimination of the countersink from cans having lids of conventional 202 size (i.e., a lid diameter of 2.25 inches) as well as smaller diameters. The countersink, though contributing to overall stiffness and resistance to buckling, is undesirable because any dirt or spillage on the lid tends to collect in the countersink; also, its presence in a lid design increases the metal required for the lid. The annular flange-peelable closure opening arrangement of the can lid of the invention, in combination with a suitable choice of alloy and gauge, enables reduction or elimination of the countersink. In such case, since the countersink (when present) contributes to the overall stiffness and resistance to buckling of the lid, addi-

tional stiffening features such as raised or depressed ribs, coined areas, or raised or depressed panel areas may be formed in the lid.

[0185] FIG. 30A, corresponding in pertinent respects to FIG. 18, shows a can lid 316a embodying the invention, including an aperture 324 closed by a peelable closure member 328 and defined by an upwardly projecting annular flange 330, having a countersink 362a of conventional shape and dimensions, e.g. about 0.090 inch deep (dimension d_1) in the case of a 202 can lid. FIG. 30B shows a similar can lid 316b in which the depth d_2 of the countersink 362b has been reduced by two-thirds (to 0.030 inch) as compared to d_1 in FIG. 30A, and the width of the countersink has also been lessened. This small countersink provides a degree of stiffening and buckle resistance but, if sufficiently shallow (an exemplary or currently preferred range being a depth of 0.015 to 0.030 inch), is less likely to accumulate dust and debris. FIG. 30C, corresponding in pertinent respects to FIG. 21, shows another similar can lid 316c in which the countersink has been entirely eliminated; in its place is a planar annular region 362c.

[0186] The choice of depth of the reduced countersink 362b (FIG. 30B) may in practice be based on consumer perception, providing the deepest possible countersink that does not attract negative attention on the part of consumers. Once a countersink depth has been established, lid gauge, alloy and other design modifications such as added stiffening features are selected to assure adequate buckle resistance.

[0187] Examples of types of stiffening features that may be formed in can lids for such purposes are illustrated in FIGS. 31A-31E, wherein the can lid is designated 316. These features include a depressed rib 364 (FIG. 31A), typically 0.03 inch deep and 0.05 inch wide; a raised rib 366 (FIG. 31B); a raised panel area 368 (FIG. 31C) with a sloped area about 0.03 inch wide and a raised area is about 0.03 inch high; a depressed panel area 370 (FIG. 31D); and a coined area 372 (FIG. 31E). The coined area is thinned, with slightly thickened regions along its edges; a typical illustrative width of a coined area is 0.03 inch but this dimension can vary considerably.

[0188] FIGS. 32A and B, 33A and B, and 34A and B illustrate various specific exemplary combinations of these features to enhance stiffness and buckle resistance in 202 can lids (each having a diameter of 2.25 inches, and respectively designated 316D, 316E and 316F), embodying the invention, and in which countersinks have been eliminated as indicated at 362c. The stiffening features are identified by the same respective reference numerals as in FIGS. 31A-31E. In FIGS. 32A and B and 33A and B, the peelable closure member 328a has a circular periphery; in FIGS. 34A and B, the aperture 324a has a shape similar to current can end apertures known in the trade as LOE (Large Opening Ends). Many variations of the illustrated arrangements are possible.

[0189] By way of further illustration of the invention, reference may be made to the following specific examples, in which Example 1 is a hypothetical example and Examples 2 and 3 describe burst resistance tests performed on actual samples of can lids with heat-sealed closures embodying features of the invention, while Example 4 describes actual tests related to shelf life. In these Examples, identifications of aluminum alloys by four-digit numbers with the prefix

“AA” refer to designations of aluminum alloy compositions registered with the Aluminum Association, as will be understood by persons skilled in the art.

EXAMPLE 1

[0190] An illustrative can end (lid) embodying the present invention with a heat sealed foil/polymer laminate closure might be constructed with the following specification:

Aperture diameter (A):	1"
Flange angle:	20–25°
Laminate:	.004" foil (AA 3104) + .001" polymer (e.g., polyethylene, polypropylene, polyester)
Heat seal width:	0.1"
Can lid sheet:	0.009" (AA 5182 alloy) with a heat sealable coating

[0191] It will be understood that a range of values for each parameter should be possible. The target burst resistance for such a lid would be >90 psi and the target peel force (at 90° to the plane of the aperture) would be <4 lbs.

EXAMPLE 2

[0192] Tests were performed to determine peel strength and burst resistance for can ends (lids) of “202” can end size (a standard can size designation) in accordance with the invention, having an annular frustoconical flange with an 18° angle of slope defining an aperture $\frac{3}{4}$ " in diameter, covered by a foil closure heat sealed to the flange around the aperture. The lids were formed from can end sheet of AA5182 aluminum alloy at a gauge of 0.0086", and their outer surfaces were coated with “Valspar” uncoat at a coating weight of 1.5 mg/in² (approximately 1.5 μ thick). The closures were made from heat sealable stock of 50 μ foil of AA3105 aluminum alloy, coated on its inner surface (the surface in contact with the aperture-defining frustoconical flange) with Rorschach TH388 vinyl heat seal lacquer at a coating weight of 6 g/m² (about 6 μ thick). Heat sealing was performed at various selected tool temperatures (on the side of the foil closure) of from 230° to 280° C., with a pressure of 975 N and a time of 0.3 sec.

[0193] Initially, to determine peel strength, T-peel test pieces were prepared from the can end sheet and heat sealable foil stock described above by heat sealing 15 mm wide strips of the foil stock to 15 mm wide can end sheet samples for different heat seal temperatures (as listed in FIG. 10). Results, summarized in FIG. 10, show that the peel strength can be adjusted for this combination of materials by modifying the heat seal temperature. As mentioned above, a peel force of between about 10 N and about 15 N is generally regarded as acceptable for an easy opening container. Since the anticipated width of the heat seal for closures embodying the present invention may be typically or conveniently approximately 15 mm, the peel forces will fall within this acceptable range.

[0194] To test burst resistance, a number of formed and heat sealed can ends as described were subjected to a standard burst test in which the rim of the can end is clamped to a rubber gasket seal and a gradually increasing air pressure is applied to the inner lid surface. The deformation

of the lid and seal can be observed during the test and the maximum pressure at failure is recorded. After testing the lids are examined to determine the mode of failure.

[0195] The results of these burst tests are shown in FIG. 11. For these tests, burst pressures of approximately 60 psi were recorded. During the tests it was noted that the foil closure 28 stretched and "domed" to a point where the tension in the foil had developed a significant peel component, i.e., the tangent (in a vertical plane) to the bulged foil closure 28 at the edge of the aperture 24 exceeded the 18° slope angle of the flange 30, as illustrated diagrammatically in FIG. 9. Failure of the seal occurred by a peel initiated at the inner edge of the aperture.

[0196] A 60 psi burst resistance is sufficient for low levels of carbonation or for normally carbonated beverages under standard conditions of use. However, since carbonated products must be capable of tolerating varying degrees of extreme conditions (elevated temperature, agitation, etc.), the normal targeted burst resistance is generally 90 psi or higher. In the case of the materials employed in this Example, higher burst resistance should be achieved with this gauge of foil if a higher flange angle (e.g. 25°) were to be used.

EXAMPLE 3

[0197] A further series of can ends in accordance with the invention were prepared and tested. The lid members were the same (dimensions, gauge, alloy, coating, flange slope angle and aperture diameter) as in EXAMPLE 2, but the closures were made of heat sealable foil stock of 70 μ foil of AA9802 aluminum alloy with an inner surface coated with a vinyl heat seal lacquer of unknown formulation. Heat sealing was performed with a tool temperature (on the foil closure side) of 280° C., under the same pressure and time conditions as in EXAMPLE 2.

[0198] These materials (can end sheet and foil closure) were subjected to peel strength testing. Peel strengths of greater than 20 N/15 mm were recorded for these samples. This is too high for convenient peeling and indicates that the vinyl lacquer was not a suitable formulation.

[0199] Samples of the lids and closures were formed, subjected to heat sealing, and tested for burst resistance. Burst resistance was found to be >90 psi. During the burst tests, the foil closures bulged to form a shallow dome, but the distortion was not sufficient to create a significant peel component to the resultant tension force.

[0200] Failure of the lids eventually occurred by distortion of the can end shell metal. The foil and the heat seal survived the test satisfactorily.

[0201] With the thicker foil of this Example, the doming which occurs at pressures below 90 psi (for the 3/4" aperture) was below the level at which a peel component of force would arise.

EXAMPLE 4

[0202] A further series of can ends in accordance with the invention were prepared and tested. The lid members differed from those of EXAMPLES 2 and 3 in having a flange slope angle of about 23° and an aperture diameter of 7/8". The can end lacquer was Valspar Unicoat (vinyl based) lacquer as before, at a thickness of between 1.5 and 2 μ . The closures were made of heat sealable foil stock of 80 μ gauge foil of AA3104 aluminum alloy with an inner surface coated with

a polystyrene/polyester blend heat seal lacquer designated TH312 (Alcan Rorschach) applied at 8 g/m². Heat sealing was performed with a top tool temperature of 200° C., a bottom tool temperature of 200° C., a dwell time of 0.3 second, and a heat seal width of 0.079 inch (2 mm). Heat sealing was carried out before the angled flange was formed.

[0203] Burst tests were performed on the lids. In tests performed before the angled flange was formed, failure of the heat seal occurred at between 40 and 55 psi. In tests performed after forming the flange, using a standard can end bulge test, failure by buckling of the can end occurred at between 85 and 90 psi. In tests also performed after forming the flange but using a modified clamping tool to prevent end buckling, failure of the heat seal occurred between about 110 psi and 120 psi (the lowest value recorded was 106 psi).

[0204] Peel strength was tested using a 90° peel test. The peel force varied during the test but was within the range between about 2½ lbs (≈11.3 Newtons) and 4 lbs (≈18 Newtons).

[0205] To test shelf life, can ends of this Example were used for cans filled with carbonated soft drinks at an estimated filling pressure of ≈60 psi and stored at ambient temperature. Samples prepared and tested in this way have maintained full pressurization for over six months.

EXAMPLE 5

[0206] The shelf life of cans in accordance with the invention was tested by preparing a can having a lid in accordance with the invention, including an angled flange having an 18° angle of slope and defining a circular aperture 0.750 inch in diameter. The closure was aluminum foil 0.004 inch (100 μ) thick, with a vinyl/acrylic lacquer ("TH 388") used for the heat seal, which had a width of 0.079 inch (2 mm). The internal pressure of the can was 50 psi. The can was examined weekly for over eight weeks. Throughout this period, there were no detectable changes in bulge height of the foil closure and there was no detectable change in the heat seal joint (i.e., no sliding).

[0207] In a further test, another can was prepared, having a lid in accordance with the invention, including an angled flange having an 18° angle of slope and defining a circular aperture 0.875 inch in diameter. The closure was aluminum foil 0.004 inch (100 μ) thick, with a vinyl/acrylic lacquer ("TH 388") used for the heat seal, which had a width of 0.079 inch (2 mm). The internal pressure of the can was 60 psi. The can was examined weekly for over six weeks. Throughout this period, there was no change in bulge height of the foil closure and no detectable change in the heat seal joint (i.e., no sliding).

[0208] It is to be understood that the invention is not limited to the features and embodiments hereinabove specifically set forth, but may be carried out in other ways without departure from its spirit.

What is claimed is:

1. A can comprising:

- (a) a metal can body having an open upper end;
- (b) a substantially rigid metal can lid secured at its periphery to and closing said can body end, said lid having an upper surface;
- (c) an annular flange formed in a portion of said lid and projecting upwardly from said lid upper surface, said flange having an upwardly sloping outer surface and an

annular inner edge lying substantially in a plane and defining an aperture with an average diameter between about 0.625 inch and about 1 inch; and

(d) a flexible closure member of a material comprising a metal foil, extending entirely over said aperture and peelably bonded by a heat seal to said flange outer surface entirely around said aperture.

2. A can as defined in claim 1, wherein said can has a geometric axis, said lid upper surface is substantially flat, said aperture is circular and said flange is disposed in a portion of said lid eccentric to said geometric axis.

3. A can as defined in claim 1, wherein said closure member and heat seal have a tear/shear force resistance of at least about lb./in., and wherein said average diameter of said aperture and the upward slope of said flange are mutually selected such that when the closure member is subjected to differential pressure of a given value between about 50 and about 100 p.s.i. within the can, the tear/shear force exerted on the closure member and heat seal does not exceed said tear/shear force resistance.

4. A can as defined in claim 3, wherein said tear/shear force resistance is between about 25 and about 75 lb./in.

5. A can as defined in claim 47, wherein said closure member material is deformable, and wherein said average diameter of said aperture, said angle of slope of said flange, and the deformability of said material are mutually selected such that said closure member, when subjected to differential pressures up to at least about 90 p.s.i. in the can, bulges upwardly with an arc of curvature such that a line tangent to said arc at said inner edge of said flange lies at an angle to said plane not substantially greater than said angle of slope of the flange outer surface.

6. A can as defined in claim 47, wherein said closure member material is deformable, and wherein said average diameter of said aperture, said angle of slope of said flange, and the deformability of said material are mutually selected such that said closure member, when subjected to differential pressures up to at least about 100 p.s.i. in the can, bulges upwardly with an arc of curvature such that a line tangent to said arc at said inner edge of said flange lies at an angle to said plane not substantially greater than said angle of slope of the flange outer surface.

7. A can as defined in claim 1, wherein said closure member and heat seal have a tear/shear force resistance of at least about 75 lb./in., and wherein said average diameter of said aperture and the upward slope of said flange are mutually selected such that when the closure member is subjected to differential pressure of not more than about 90 p.s.i. within the can, the tear/shear force exerted on the closure member and heat seal does not exceed said tear/shear force resistance.

8. A can as defined in claim 1, wherein said closure member and heat seal have a tear/shear force resistance of at least about 75 lb./in., and wherein said average diameter of said aperture and the upward slope of said flange are mutually selected such that when the closure member is subjected to differential pressure of not more than about 100 p.s.i. within the can, the tear/shear force exerted on the closure member and heat seal does not exceed said tear/shear force resistance.

9. A can as defined in claim 47, wherein said closure member and heat seal have a tear/shear force resistance of at least about 75 lb./in., and wherein said average diameter of said aperture and said angle of slope of said flange are

mutually selected such that when the closure member is subjected to differential pressure of not more than about 90 p.s.i. within the can, the tear/shear force exerted on the closure member and heat seal does not exceed said tear/shear force resistance.

10. A can as defined in claim 6, wherein said closure member and heat seal have a tear/shear force resistance of at least about 75 lb./in., and wherein said average diameter of said aperture and said angle of slope of said flange are mutually selected such that when the closure member is subjected to differential pressure of not more than about 100 p.s.i. within the can, the tear/shear force exerted on the closure member and heat seal does not exceed said tear/shear force resistance.

11. A can as defined in claim 1, wherein said heat seal has a 90° peel strength between about 8 N and about 20 N.

12. A can as defined in claim 1, wherein said annular inner edge is formed with a reverse bead curl.

13. A can as defined in claim 12, wherein said reverse bead curl is substantially tangent to the upwardly sloping outer surface of the flange.

14. A can as defined in claim 1, wherein said metal foil is aluminum alloy foil.

15. A can as defined in claim 14, wherein said aluminum alloy foil has a thickness between about 0.003 inch and about 0.004 inch.

16. A can as defined in claim 1, wherein said heat seal is formed as an annulus surrounding said aperture and having a width between about 0.079 inch and about 0.118 inch.

17. A can as defined in claim 1, wherein said closure has a tab portion with a manually graspable free end and an extension overlying said lid in opposed relation to said tab portion, said heat seal including an annulus surrounding said aperture and a further seal portion bonding said extension to said lid such that the peel force required to separate the extension from the lid is greater than that required to separate the closure member from the lid at the annulus, whereby the aperture can be opened by peeling back the closure member while the closure member remains secured to the lid by said further seal portion.

18. A can as defined in claim 17, including a body of fragrance-providing material disposed between the closure member and the lid and surrounded by the heat seal such that when the closure member is subjected to a peel force effective to open the aperture, the body of fragrance-providing material becomes exposed.

19. A can as defined in claim 1, including a body of fragrance-providing material disposed between the closure member and the lid and surrounded by the heat seal such that when the closure member is subjected to a peel force effective to open the aperture, the body of fragrance-providing material becomes exposed.

20. A can as defined in claim 1, wherein said body is a drawn and ironed metal can body for holding a carbonated beverage; wherein the lid is formed with a peripheral rim engaging the open upper end of the can body and projecting upwardly above the upper surface of the lid; wherein the body is formed with an outwardly concave lower end, the rim and body lower end being mutually shaped and dimensioned to permit stable vertical stacking of the can with other identically shaped and dimensioned cans; wherein the flexible closure member is domed so as to rise to a height above the annular flange; and wherein the height of the rim, the concavity of the body lower end, and the height to which the

closure rises above the annular flange are such that there is sufficient clearance between the lid upper surface of the can and the concave bottom of another identical can stacked above it to accommodate the domed closure.

21. A can lid member mountable on a metal can body having an open upper end so as to be secured at its periphery to and to close said can body end, said lid comprising a substantially rigid unitary metal member having an upper surface with an annular flange formed in a portion of said lid and projecting upwardly from said lid upper surface, said flange having an upwardly sloping outer surface and an annular inner edge lying substantially in a plane and defining an aperture with an average diameter between about 0.625 inch and about 1 inch, said flange being arranged and configured to be closed by a flexible closure member extending entirely over said aperture and peelably bonded to said flange outer surface around said aperture.

22. A can lid mountable on a metal can body having an open upper end so as to be secured at its periphery to and to close said can body end, said lid comprising a substantially rigid unitary metal can lid member having an upper surface with an annular flange formed in a portion of said lid and projecting upwardly from said lid upper surface, said flange having an upwardly sloping outer surface and an annular inner edge lying substantially in a plane and defining an aperture with an average diameter between about 0.625 inch and about 1 inch; and a flexible metal foil closure member extending entirely over said aperture and peelably bonded by a heat seal to said flange outer surface entirely around said aperture.

23. A carbonated, or otherwise pressurized, beverage package comprising:

- (a) a can including a metal can body having an open upper end and a substantially rigid metal can lid secured at its periphery to and closing said can body end, said lid having an upper surface;
- (b) a body of a carbonated, or otherwise pressurized, beverage contained within said can;
- (c) an annular flange formed in said lid and projecting upwardly from said lid upper surface, said flange having an upwardly sloping outer surface and an annular inner edge lying substantially in a plane and defining an aperture with an average diameter between about 0.625 inch and about 1 inch; and
- (d) a flexible metal foil closure member extending entirely over said aperture and peelably bonded by a heat seal to said flange outer surface entirely around said aperture.

24. A method of producing a can containing a carbonated, or otherwise pressurized, beverage, comprising:

- (a) filling a drawn and ironed metal can body, having an open upper end, with a carbonated, or otherwise pressurized, beverage, and
- (b) closing said open upper end of said can body by securing a substantially rigid metal can lid at its periphery to said can body end, said lid having an upper surface and an annular flange formed in said lid and projecting upwardly from said lid upper surface, said flange having an upwardly sloping outer surface and an annular inner edge lying substantially in a plane and defining an aperture with an average diameter between

about 0.625 inch and about 1 inch, and a flexible metal foil closure member extending entirely over said aperture and peelably bonded by a heat seal to said flange outer surface entirely around said aperture.

25. A can for holding liquid, comprising:

- (a) a metal can body having an open upper end;
- (b) a substantially rigid metal can lid peripherally secured to and closing said can body end, said lid having an upper surface and defining an aperture therein for pouring or drinking liquid from the can; and
- (d) a flexible closure member extending entirely over said aperture and peelably bonded by a heat seal to said lid entirely around said aperture;

wherein the improvement comprises:

- (e) said closure including a tab portion with a manually graspable free end and an extension overlying said lid in opposed relation to said tab portion, said heat seal including an annulus surrounding said aperture and a further seal portion bonding said extension to said lid such that the peel force required to separate the extension from the lid is greater than that required to separate the closure member from the lid at the annulus, whereby the aperture can be opened by peeling back the closure member while the closure member remains secured to the lid by said further seal portion.

26. A can for holding liquid, comprising:

- (a) a metal can body having an open upper end;
- (b) a substantially rigid metal can lid peripherally secured to and closing said can body end, said lid having an upper surface and defining an aperture therein for pouring or drinking liquid from the can; and
- (d) a flexible closure member extending entirely over said aperture and peelably bonded by a heat seal to said lid entirely around said aperture;

wherein the improvement comprises:

- (e) a body of fragrance-providing material disposed between the closure member and the lid and surrounded by the heat seal such that when the closure member is subjected to a peel force effective to open the aperture, the body of fragrance-providing material becomes exposed.

27. A can as defined in claim 1, wherein the can lid is formed of the same alloy as the can body.

28. A can as defined in claim 27, wherein said alloy is AA3104 alloy or AA 3004 alloy.

29. A can as defined in claim 1, wherein the can lid is formed of AA3104 alloy or AA 3004 alloy.

30. A can as defined in claim 1, wherein the can lid is formed of steel.

31. A can as defined in claim 1, wherein the can lid has a diameter of less than two inches.

32. A can as defined in claim 31, wherein the can lid has a gauge of less than 0.0082 inch.

33. A can as defined in claim 31, wherein the can lid is substantially free of countersinking.

- 34.** A can comprising:
- (a) a metal can body having an open upper end, a lower portion with a maximum diameter and an upper portion formed as a neck of reduced diameter relative to said maximum diameter;
 - (b) a substantially rigid metal can lid secured at its periphery to and closing said can body end, said lid having an upper surface;
 - (c) an annular flange formed in a portion of said lid and projecting upwardly from said lid upper surface, said flange having an upwardly sloping outer surface and an annular inner edge lying substantially in a plane and defining an aperture; and
 - (d) a flexible closure member of a material comprising a metal foil, extending entirely over said aperture and peelably bonded by a heat seal to said flange outer surface entirely around said aperture.
- 35.** A can as defined in claim 34, wherein said body is a drawn and ironed metal can body having an initially cylindrical sidewall with an upper portion, and wherein said neck is produced by forming said sidewall upper portion.
- 36.** A can as defined in claim 34, wherein said body is a drawn and ironed metal can body having a generally cylindrical sidewall, an initially closed end portion integral therewith, and an open second end; wherein said neck is produced by forming said end portion; wherein said open second end is closed by seaming a can end thereto; and wherein said open upper end is produced by forming an endwise opening in said neck.
- 37.** A can as defined in claim 1, wherein the annular flange is frustoconical.
- 38.** A can as defined in claim 1, wherein the can lid is substantially free of countersinking.
- 39.** A can as defined in claim 38, wherein the can lid is formed with stiffening features.
- 40.** A can as defined in claim 39, wherein said stiffening features are selected from the group consisting of raised ribs, depressed ribs, raised panel areas, depressed panel areas and coined areas.
- 41.** A can as defined in claim 1, wherein the can lid has a diameter of about 2.25 inches and a countersink not more than about 0.03 inch deep.
- 42.** A can as defined in claim 41, wherein the can lid is formed with stiffening features selected from the group consisting of raised ribs, depressed ribs, raised panel areas, depressed panel areas and coined areas.
- 43.** A can as defined in claim 38, wherein the can lid has a diameter of about 2.25 inches.
- 44.** A can lid as defined in claim 22, wherein the can lid member is substantially free of countersinking.
- 45.** A beverage package as defined in claim 23, wherein the can lid is substantially free of countersinking.
- 46.** A can as defined in claim 45, wherein the can lid is formed with stiffening features selected from the group consisting of raised ribs, depressed ribs, raised panel areas, depressed panel areas and coined areas.
- 47.** A can as defined in claim 1, wherein said flange outer surface is oriented at an angle of slope between about 12.5° and about 40° to said plane.
- 48.** A can lid member as defined in claim 21, wherein said flange outer surface is oriented at an angle of slope between about 12.5° and about 40° to said plane.
- 49.** A can lid as defined in claim 22, wherein said flange outer surface is oriented at an angle of slope between about 12.5° and about 40° to said plane.
- 50.** A beverage package as defined in claim 23, wherein said flange outer surface is oriented at an angle of slope between about 12.5° and about 40° to said plane.
- 51.** A method as defined in claim 24, wherein said flange outer surface is oriented at an angle of slope between about 12.5° and about 40° to said plane.
- 52.** A can as defined in claim 1, wherein said flange outer surface is oriented at an angle of slope between about 20° and about 35° to said plane.
- 53.** A can lid member as defined in claim 21, wherein said flange outer surface is oriented at an angle of slope between about 20° and about 35° to said plane.
- 54.** A can lid as defined in claim 22, wherein said flange outer surface is oriented at an angle of slope between about 20° and about 35° to said plane.
- 55.** A beverage package as defined in claim 23, wherein said flange outer surface is oriented at an angle of slope between about 20° and about 35° to said plane.
- 56.** A method as defined in claim 24, wherein said flange outer surface is oriented at an angle of slope between about 20° and about 35° to said plane.
- 57.** A can as defined in claim 1, wherein said flange outer surface is oriented at an angle of slope between about 12.5° and about 30° to said plane.
- 58.** A can lid member as defined in claim 21, wherein said flange outer surface is oriented at an angle of slope between about 12.5° and about 30° to said plane.
- 59.** A can lid as defined in claim 22, wherein said flange outer surface is oriented at an angle of slope between about 12.5° and about 30° to said plane.
- 60.** A beverage package as defined in claim 23, wherein said flange outer surface is oriented at an angle of slope between about 12.5° and about 30° to said plane.
- 61.** A method as defined in claim 24, wherein said flange outer surface is oriented at an angle of slope between about 12.5° and about 30° to said plane.

* * * * *