

May 23, 1950

A. F. LUKES

2,508,615

EXHAUST VALVE FOR INTERNAL-COMBUSTION ENGINES

Filed April 22, 1946

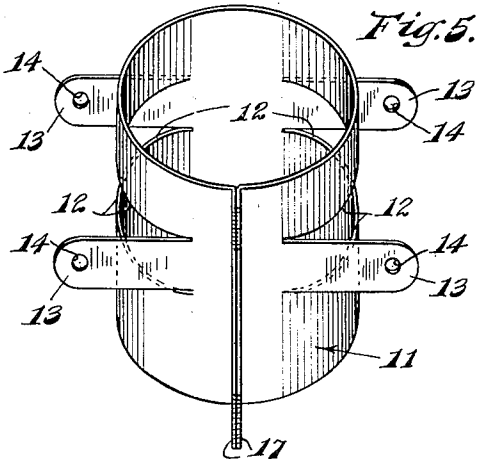
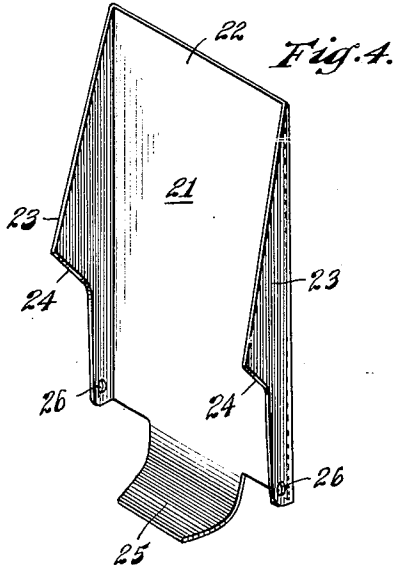
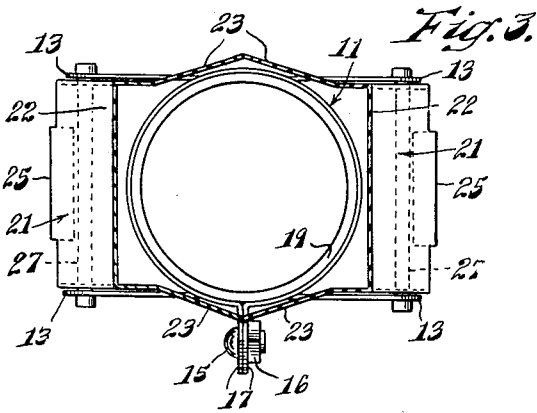
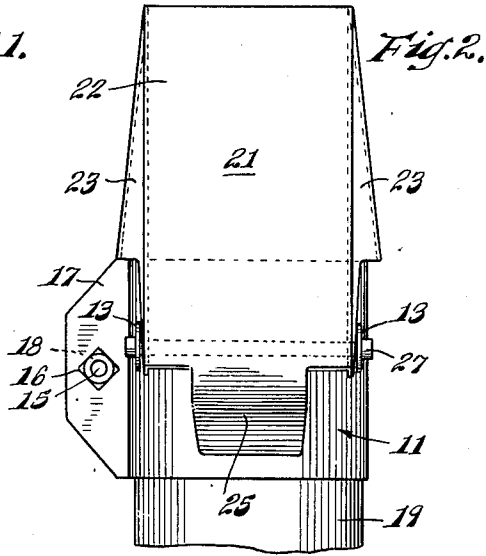
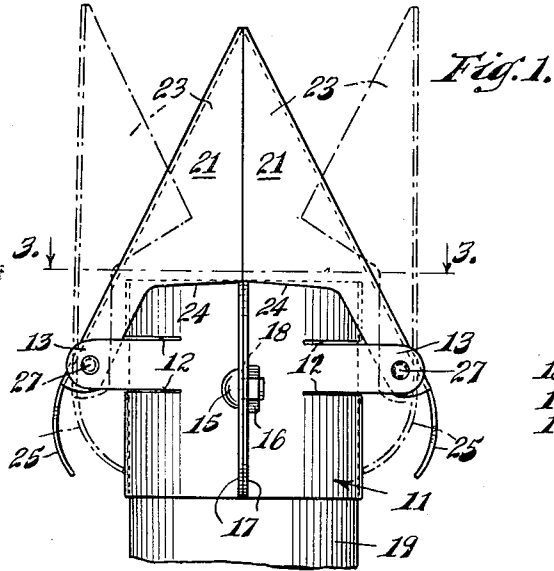

Inventor.
Adolph F. Lukes.
By Bair & Dreeman
Atty's

UNITED STATES PATENT OFFICE

2,508,615

EXHAUST VALVE FOR INTERNAL-COMBUSTION ENGINES

Adolph F. Lukes, Waterloo, Iowa

Application April 22, 1946; Serial No. 663,770

2 Claims. (Cl. 98-59)

1

This invention relates to an exhaust valve for internal combustion engines and particularly to a valve for protecting that opening of a vertical internal engine exhaust pipe which exhausts gases from the engine to the atmosphere.

It is an object of the invention to provide an exhaust valve for the purpose described which is substantially permanently secured to the exhaust pipe of the engine and which does not interfere with the free exhaust of gases and at the same time effectively prevents dust, snow, and rain from entering the exhaust pipe when the engine is not operating. If such foreign materials enter the exhaust pipe when the vehicle is standing outdoors and the internal combustion engine is not operating, trouble in starting and operation of the engine and deterioration of the exhaust pipe and fittings inevitably result.

It is also an object of the invention to dispense with makeshift covers for vertical exhaust pipes for internal combustion engines, such as tin cans and the like, and to provide a practical, permanent exhaust valve for excluding foreign matter from such exhaust pipes.

Another object of the invention is to provide an exhaust valve of the type described which is readily opened by the passage of exhaust gases, and further to provide such ready opening by a plurality of slightly counterweighted similarly shaped pivoted flaps which cooperate to close the top of the exhaust pipe when the engine is idle.

It is another object of the invention to form the exhaust valve of a minimum of stamped parts to reduce the cost thereof and utilize as few dies as possible; more particularly, it is an object of the invention to provide two dies to make three stamped parts which, with pivot pins, form the entire valve.

With these and other objects in view, my invention consists in the construction, arrangement and combination of the various parts of my device whereby the objects contemplated are attained, as hereinafter more fully set forth, pointed out in my claims and illustrated in the accompanying drawings, wherein:

Figure 1 is a front view of the exhaust valve applied to the top of an exhaust pipe, the dot and dash lines showing the flaps in the open position;

Figure 2 is a side view of the exhaust valve shown in Figure 1;

Figure 3 is a horizontal sectional view taken on line 3-3 of Figure 1;

Figure 4 is a detail perspective view of one of the similar flaps; and

2

Figure 5 is a detail perspective view of the collar which surrounds the exhaust pipe and supports the flaps.

Referring to the drawing for a detailed description of the invention, numeral 11 designates a collar which is preferably formed from a single flat sheet of metal which is punched to form slots 12 from which four ears 13 are bent. Holes 14 are provided in the ears 13. After cutting and bending the ears, the flat sheet of metal is rolled and a nut and bolts 15 and 16 pull vertical edges 17 together by passing through holes 18 in the edges 17 so that the collar may be readily slid over an exhaust pipe 19 of an internal combustion engine (not shown).

Two preferably similar sheet metal flaps, generally indicated by the numeral 21, are formed of sheet metal in the same die and comprise a flat portion 22 having flanged vertical edges 23, shouldered at 24 and bent slightly outwardly above the shoulders, and a rounded projection 25 on the bottom of the flat portion to form a stop. Holes 26 are provided in the bottoms of the flanges 23 and a pivot pin 27 for each flap 21 extends through the holes 26 in the flap and holes 14 in the ears 13 to pivotally support the flaps 21 on the ears 13.

As is apparent from Figure 1, when the flaps 21 are in the closed position, the shoulders 24 are substantially horizontal and the flanges 23 above the shoulders meet in a substantially vertical line, while the tops of the flat portions 22 of the flaps 21 meet in a substantially horizontal line. The top of the exhaust pipe 19 is, therefore, completely and effectively covered to prevent the ingress of snow, rain or dust. Furthermore, it will be noted that the center of gravity of the flaps 21 is above and slightly inwardly of the pivot pins 27, so that gravity normally retains the flaps in the closed position shown in the full lines of Figure 1.

However, when the engine is operating, the pressure of the exhaust gases strikes the flat surfaces 22 of the flaps 21 and the flaps pivot about the pins 27 and assume the position shown in dot and dash lines in Figure 1, thus permitting unrestricted exhaust of gases from the exhaust pipe 19. It is obvious that at this time foreign matter will not enter the exhaust pipe, or if snow or rain does enter, it is quickly vaporized by the hot exhaust gases. The stops 25 strike the collar 11 and prevent further rotation of the flaps, the center of gravity thereof still remaining above and inwardly of the pivot pins 27, so that upon cessation of the passage of exhaust gases, the

3

flaps 21 fall by gravity to the full line position shown in Figure 1.

Although I have herein shown and described a preferred embodiment of my invention, manifestly it is susceptible of modification and rearrangement of the parts without departing from the spirit and scope thereof. I do not, therefore, wish to be understood as limiting my invention to the precise form herein disclosed, except as I may be so limited by the appended claims.

I claim as my invention:

1. In an exhaust valve for use with an upwardly extending exposed terminal portion of an exhaust pipe of an internal combustion engine, a collar member formed of a single sheet of material having two pairs of oppositely facing ears punched and projecting therefrom, said projecting pairs of ears lying in vertical planes and supporting horizontal pins extending between each pair of ears, said sheet material being bent to form the annular collar and to position the two pairs of ears diametrically, means for securing the ends of the collar together to clamp said collar on said exhaust pipe, a plurality of substantially identical flaps, each having a pair of oppositely facing flanges thereon, said flanges having apertures therein adapted to pivotally mount said flaps on said horizontally extending pins, said flaps being adapted to cover said exhaust pipe when the engine is idle and to uncover the exhaust pipe when the engine is running and exhaust gases are forced against said flaps, and means for limiting the uncovering movement of said flaps to a position insuring movement of said flaps toward closed position upon reduction of pressure of the exhaust gases.

2. In an exhaust valve for use with an upwardly extending exposed terminal portion of an exhaust pipe of an internal combustion engine, a pair of flaps for covering and uncovering said open end of the exhaust pipe, said flaps being identical in shape, a collar secured to said pipe for pivotally supporting said flaps, said collar being formed of a single sheet of material bent to cylindrical shape, said flaps each being formed

4

of a single piece and comprising a substantially rectangular flat surface, a pair of flanges bent to oppositely facing positions at substantially right angles to said flat surface, and a curved tab projected from the bottom edge of the flap, said flaps being positioned so that the exhaust gases impinge against the flat surface so as to open the flaps, the curved tab projecting from the bottom edge of the flap positioned to cooperate with the exhaust stack to limit the opening movement of the flaps to a position insuring movement of said flaps toward closed position upon reduction of pressure of the exhaust gases, said oppositely facing flanges having apertures therein adjacent their lower ends for pivotally mounting the flap upon said collar, the upper portion of said flanges being wedge-shaped and tapering to a vertex at the upper edge of said flap, said wedge-shaped portions of the flanges of one flap cooperating with similar wedge-shaped portions of the flanges of the other flap to form side closures of the region above the terminal portion of the exhaust pipe and the upper edges of the flat surfaces of the flaps also cooperating with each other to form a closure.

ADOLPH F. LUKES.

REFERENCES CITED

The following references are of record in the file of this patent:

UNITED STATES PATENTS

Number	Name	Date
544,390	Shannon	Aug. 13, 1895
1,045,481	Walther	Nov. 26, 1912
1,064,734	Howe	June 17, 1913
1,090,389	French et al.	Mar. 17, 1914
1,222,394	Grimes	Apr. 10, 1917
1,503,915	Posner	Aug. 5, 1924
1,532,635	Osburn	Apr. 7, 1925
2,350,102	Fairbanks	May 30, 1944
2,396,567	Goddard	Mar. 12, 1946
2,420,700	Curphy	May 20, 1947
2,421,838	Harmon et al.	June 10, 1947