

(21) Application No: 1904804.0

(22) Date of Filing: 04.04.2019

(71) Applicant(s):
Mill Industries Limited
 8 Aysgarth Close, NUNEATON, Warwickshire,
 CV11 6WA, United Kingdom

(72) Inventor(s):
Roy Allen McCarthy

(74) Agent and/or Address for Service:
IP-Active.com Ltd
 The TechnoCentre,
 Coventry University Technology Park, Puma Way,
 Coventry, CV1 2TT, United Kingdom

(51) INT CL:
B66F 19/00 (2006.01) **A61G 3/06** (2006.01)
B62B 1/22 (2006.01)

(56) Documents Cited:
GB 2552938 A **CN 203753178 U**

(58) Field of Search:
 INT CL **A61G, B60S, B62B, B66F**
 Other: **WPI, EPODOC**

(54) Title of the Invention: **Lifting devices**
 Abstract Title: **Lifting device for loading a mobility scooter into a vehicle**

(57) A lifting device 10 for lifting a relatively heavy and/or bulky item 12 such as a mobility scooter into and out of a vehicle load carrying space 14 includes a hook part 18 with a relatively low friction contact surface such as a roller or wheel 24 and a load attachment part 16 with one or more load attachment surfaces 20 and a securing arrangement 22 such as flexible straps 34. In use the contact surface contacts and is moved along a load carrying surface 26 of the vehicle load carrying space 14. The hook part 18 may extend from a side of the device 10 opposite to the side upon which the item 12 is secured.

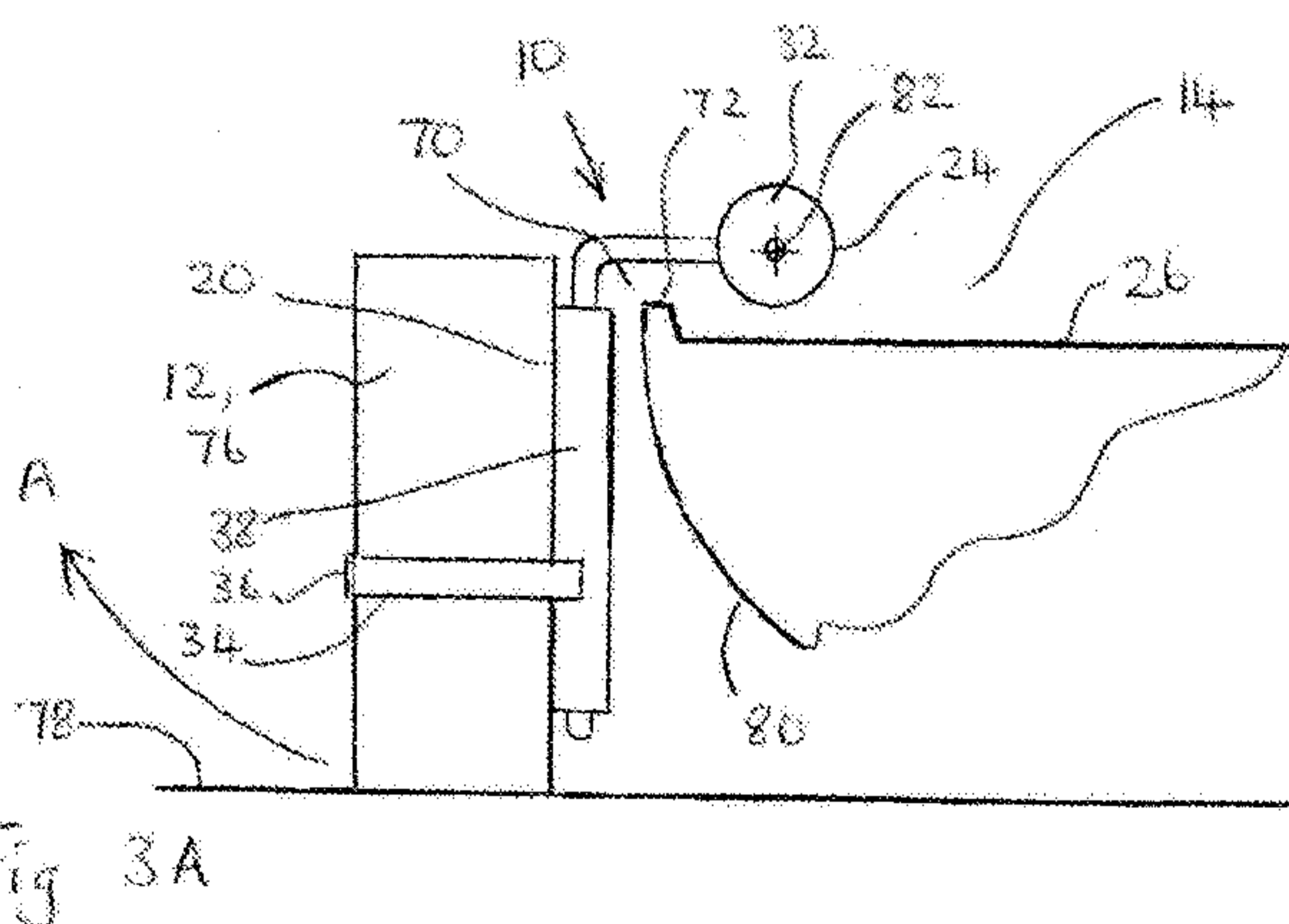
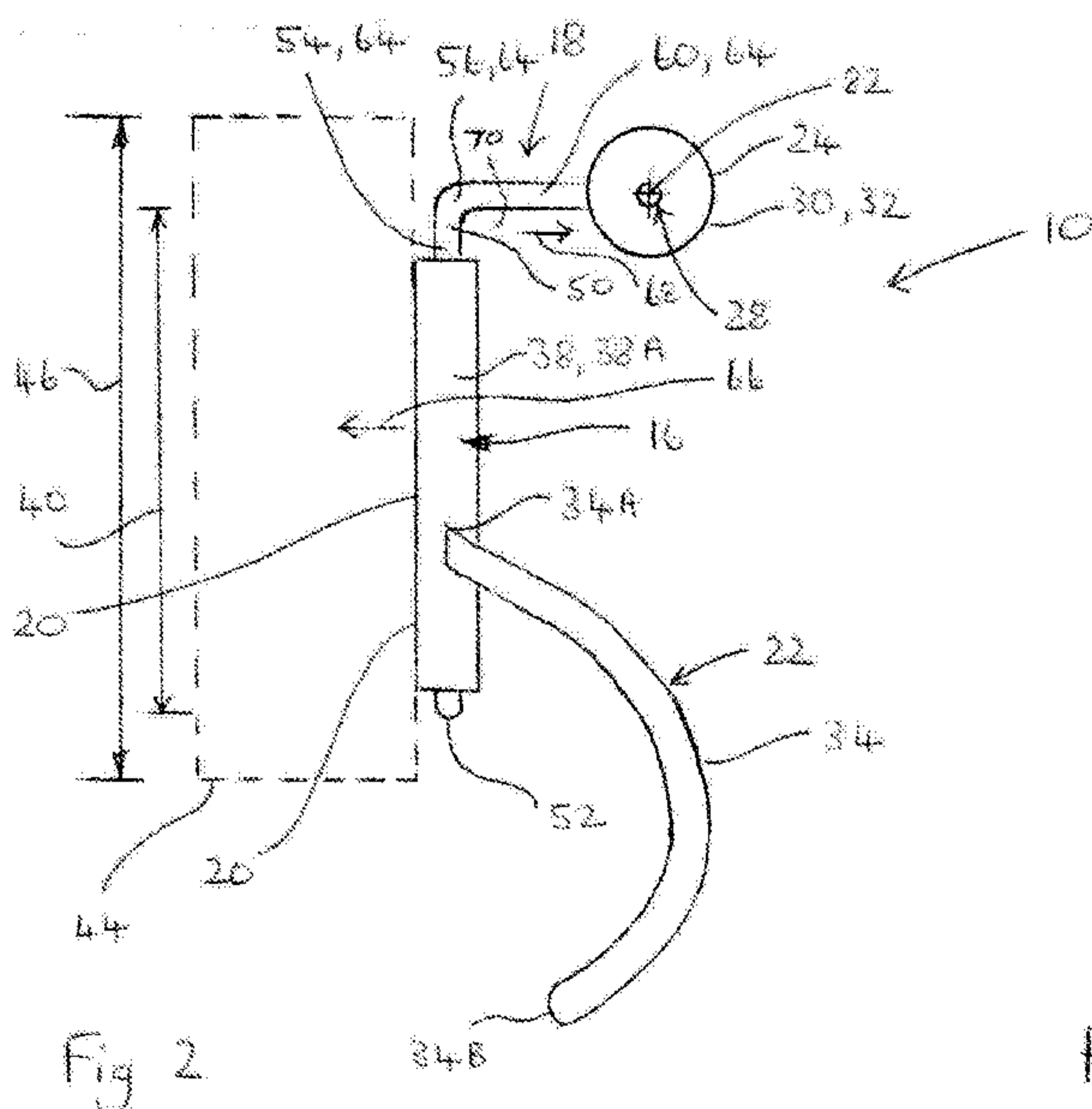

1/2

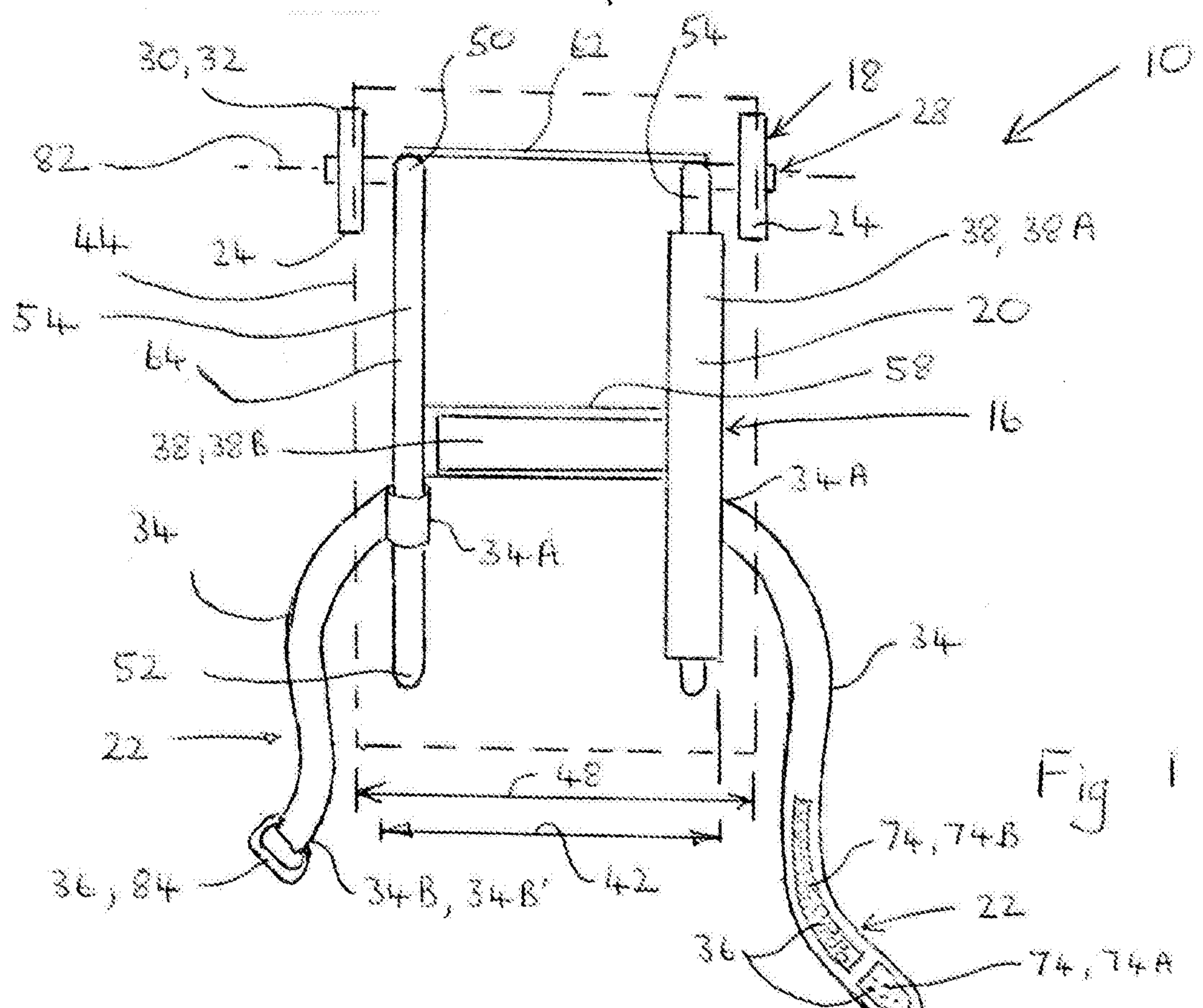

Fig 1

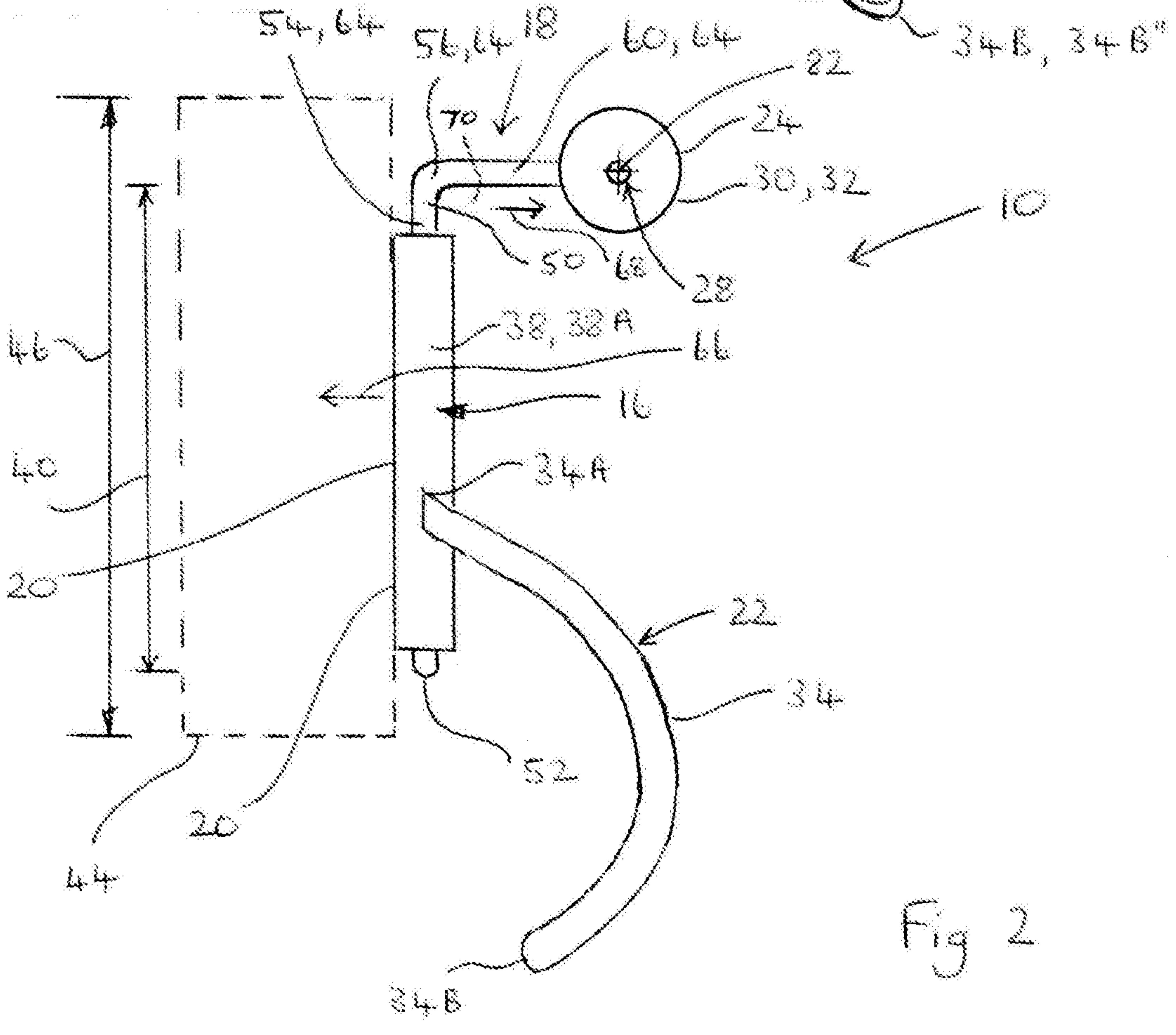

Fig 2

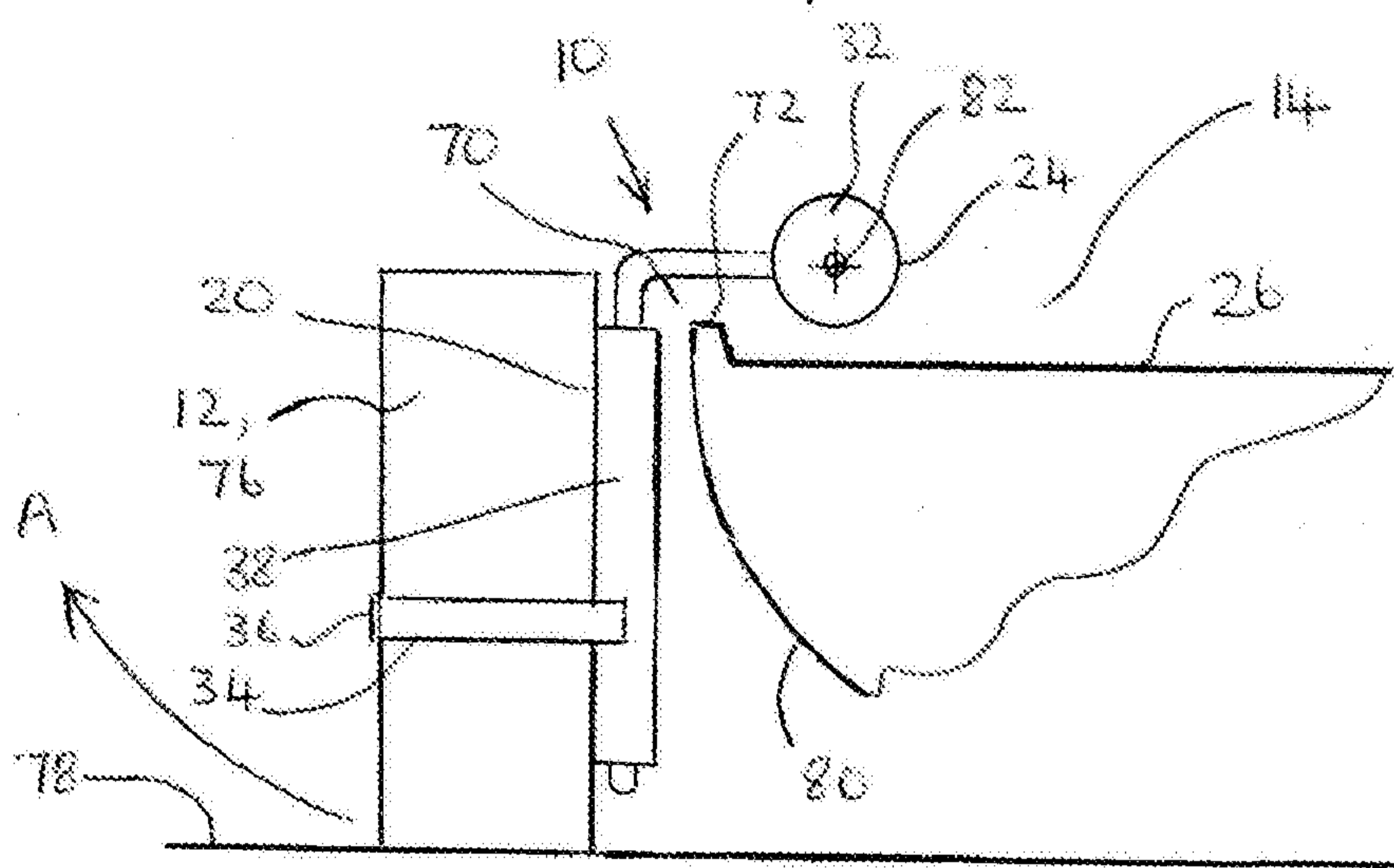

Fig 3A

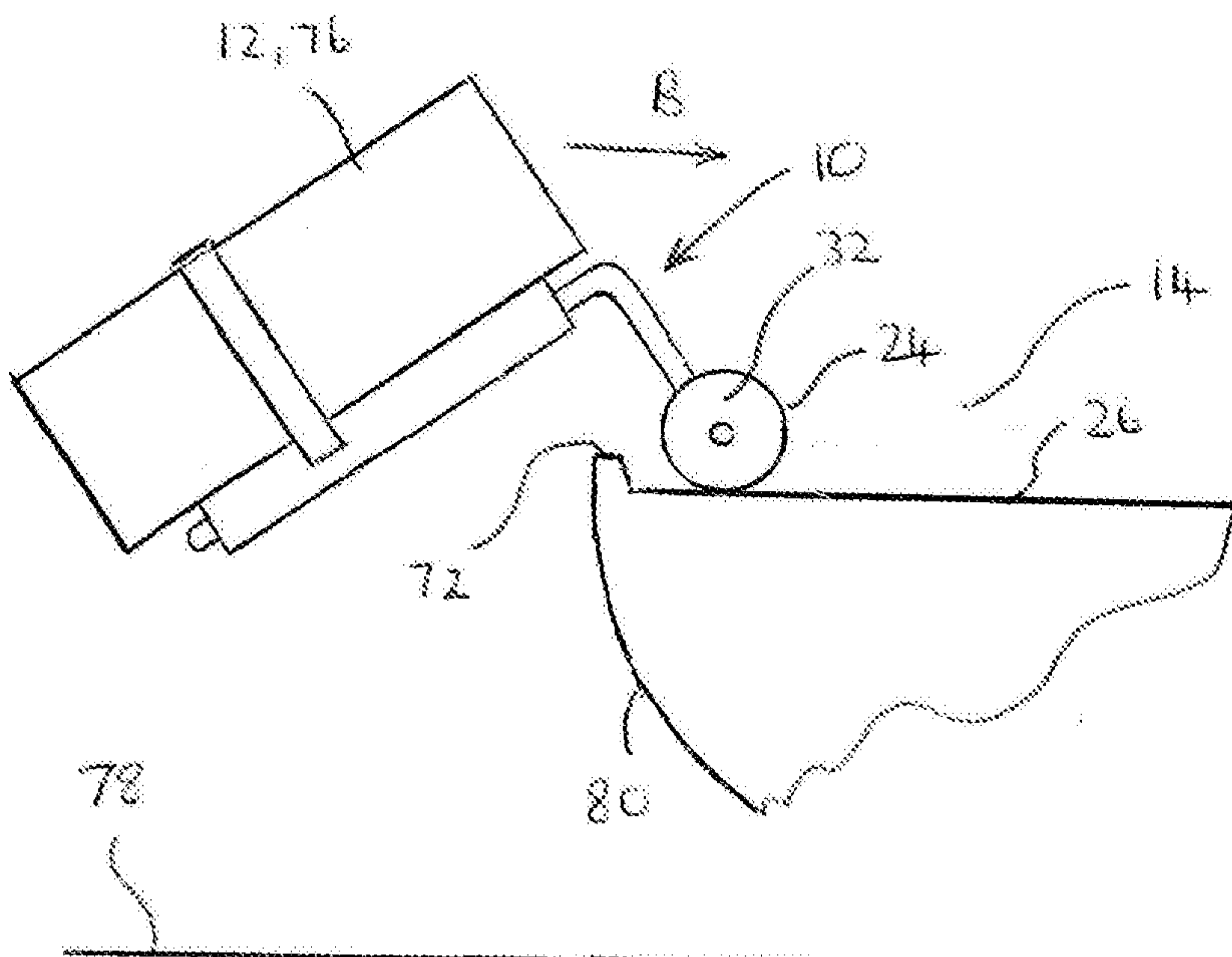

Fig 3B

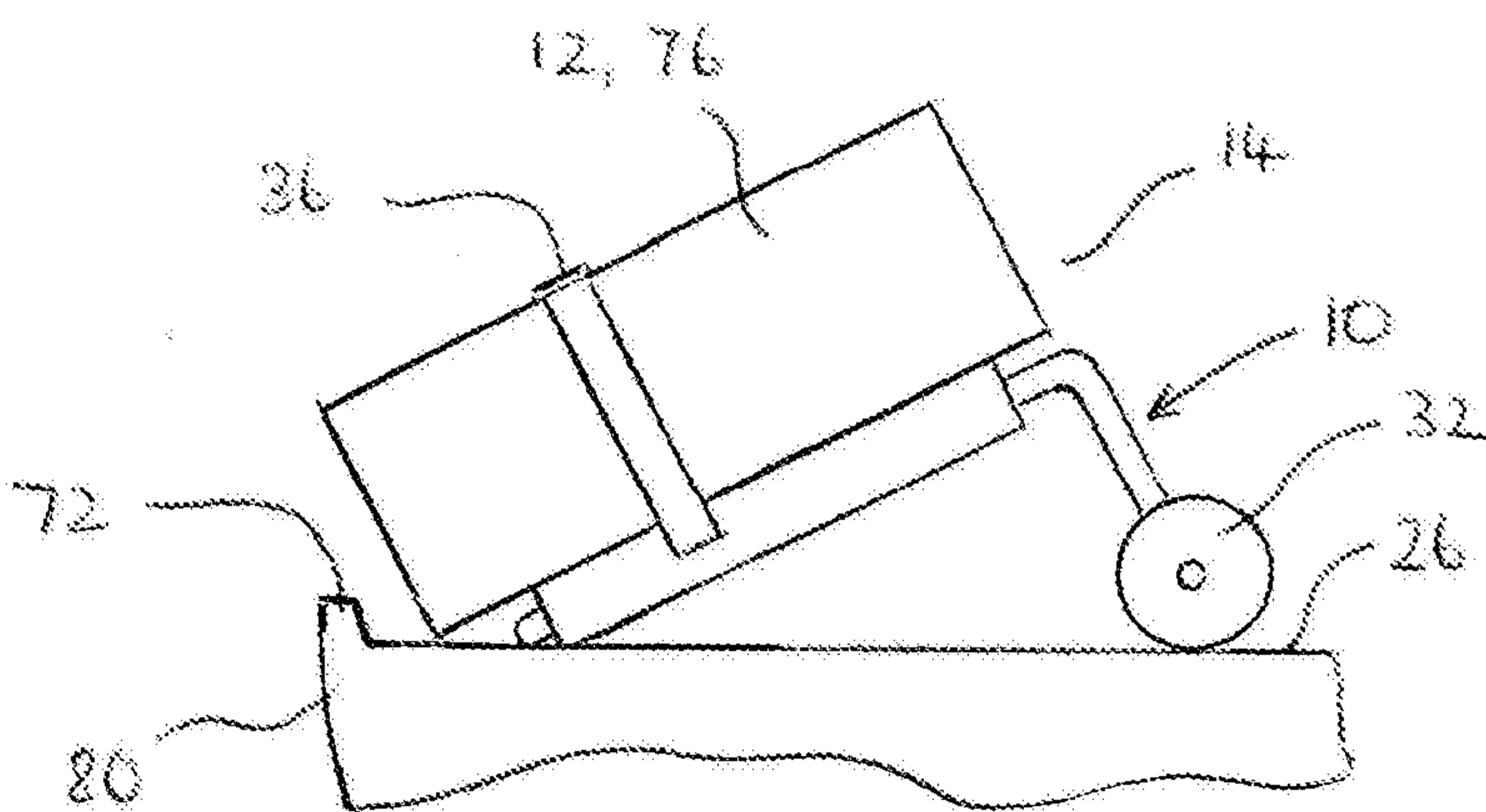

Fig 3C

Lifting Devices

Technical Field

5 The present invention relates to lifting devices, particularly but not exclusively lifting devices for lifting heavy and/or bulky items such as mobility scooters into and out of vehicle load carrying spaces.

Background

10

 Mobility scooters have become popular as a way of providing those who find walking difficult with some mobility and thus a measure of independence. However, mobility scooters can be difficult to load into vehicles since they comprise a heavy battery and motor. Various solutions have been put forward to overcome this problem. One solution comprises providing a relatively small folding scooter which can be folded into a compact size for ease of handling. However, even in a relatively compact folded condition, the scooter and the battery remain an inconveniently heavy item. Another solution comprises installing a small hoist arm in the vehicle to lift the scooter. However, hoist arms are expensive, involve an inherent risk in lifting a heavy load and require a degree of skill, strength and dexterity to operate. Hoist arms also require ongoing maintenance and safety checks.

15

20

Statements of Invention

25

 According to a first aspect of the present invention, there is provided a lifting device for lifting a relatively heavy and/or bulky item such as a mobility scooter into and out of a vehicle load carrying space, the device including a load attachment part and a hook part, the load attachment part comprising one or more load attachment surfaces to which, in use, in a loaded condition, the item is attached, the device including a securing arrangement for securing the item to the load attachment part, the hook part including a relatively low friction contact surface which, in use, contacts and is moved along a load carrying surface of the vehicle load carrying space.

30

Possibly, the contact surface is curved, and, in use, may roll relative to the load attachment part. Possibly, in use, in loading the item into the vehicle load carrying space, the contact surface rolls along the load carrying surface.

5

Possibly, the hook part includes a hook part member. Possibly, the hook part includes a rotational mounting, which may rotationally mount the contact surface to the hook part member.

10

Possibly, the contact surface is a surface of a roller. Possibly, the roller is a wheel.

15

Possibly, the hook part comprises a pair of spaced apart contact surfaces, and may comprise a pair of the wheels, a pair of the rotational mountings and a pair of the hook part members. Possibly, each wheel is mounted to one of the hook part members by one of the rotational mountings. Possibly, each of the wheels comprises one of the contact surfaces.

20

Possibly, each of the wheels is mounted for rotation around a common axis.

25

Possibly, the hook part and the load attachment part define a hook space therebetween, in which, in use, a vehicle edge/lip is receivable.

Possibly, the securing arrangement comprises a pair of flexible strap members, each of which may extend from the load attachment part and which together, in use, in the loaded condition, may extend around the item.

30

Possibly, the securing arrangement includes a releasable fastening, which is movable between an open condition in which the item can be moved towards or away from the load attachment surface and a fastened condition in which the item cannot be moved towards or away from the load attachment surface.

Possibly, the releasable fastening comprises any from the group containing hook and loop/fleece material, a ratchet fastening, a buckle, a prong buckle, a roll pin buckle, a quick release buckle, a tie-down cam buckle, a slide
5 buckle.

Possibly, the or each load attachment surface is directed in a first direction. Possibly, the hook part extends from the load attachment part in a second direction, which is an opposite direction to the first direction.
10

Possibly, the load attachment part includes cushioning for contact with the item. Possibly, the or each load attachment surface comprises part of surfaces of the cushioning.

15 Possibly, the load attachment part is substantially planar. Possibly, the load attachment part has a length and a width.

Possibly, the load attachment part defines a load space.

20 Possibly, the device is movable between the loaded condition, in which an item is located in the load space, possibly against or on the load attachment part, and an unloaded condition, which the item has not been located in the load space.

25 Possibly, in the unloaded condition, the load space is substantially free of obstruction.

Possibly, the load space has a length and a width. Possibly, the load space length is at least as long as the load attachment part length. Possibly,
30 the load space width is at least as wide as the load attachment part width.

Possibly, the load attachment part includes a first end and a second end. Possibly, the load space extends beyond one or both ends of the load attachment part.

5 Possibly, the hook part extends from the load attachment part on an opposite side of the load attachment part to the load space, and may extend from a location at or towards the first end of the load attachment part.

10 Possibly, at the second end of the load attachment part, the load attachment part is plain ended.

Possibly, the load attachment part comprises a pair of longitudinally extending load attachment part members.

15 Possibly, each of the load attachment part members is, at the first end, connected to one of the hook part members, possibly by a connector part, which may comprise a substantially 90° bend.

20 Possibly, the device includes a pair of frame members, each of which may be in the form of a tube and may be formed of a metal such as mild steel. Each frame member may comprise one of the load attachment part members, one of the connector parts and one of the hook part members, and may be formed integrally.

25 Possibly, at the second end, the or each of the load attachment part members is plain ended.

Possibly, the load attachment part includes one or more bracing members, which may extend between the load attachment part members.

30

Possibly, the hook part includes a bracing member, which may extend between the hook part members.

Possibly, the lifting device is a mobility scooter lifting device, for lifting a mobility scooter. Possibly, the mobility scooter is in a folded condition during lifting.

5 According to a second aspect of the present invention, there is provided a method of lifting a relatively heavy and/or bulky item such as a mobility scooter into and out of a vehicle load carrying space, the method including providing a lifting device, the device including a load attachment part and a hook part, the load attachment part comprising one or more load attachment surfaces to
10 which, in use, an item is attached, the device including a securing arrangement for securing the item to the load attachment part, the hook part including a relatively low friction contact surface which in use contacts and is moved along a load carrying surface of the vehicle load carrying space.

15 Possibly, the device includes any of the features described in any of the preceding statements or following description. Possibly, the method includes any of the steps described in any of the preceding statements or following description.

20 Figures

An embodiment of the present invention will now be described, by way of example only, and with reference to the accompanying drawings, in which:-

25 Fig. 1 is a front view of a lifting device, with a load space indicated in dashed lines;

 Fig. 2 is a side view of the device, again with the load space indicated in dashed lines;

 Figs. 3A to 3C are schematic side views showing steps in the use of the
30 lifting device in lifting a relatively heavy and/or bulky item such as a mobility scooter into and out of a vehicle load carrying space.

In the drawings, where multiple instances of the same or similar features exist, only a representative one or some of the instances of the features have been provided with numeric references for clarity.

5 Description

10 Figs. 1 to 3 show a lifting device 10 for lifting a relatively heavy and/or bulky item 12 such as a mobility scooter into and out of a vehicle load carrying space 14. The device 10 includes a load attachment part 16 and a hook part 18.

15 The load attachment part 16 comprises one or more load attachment surfaces 20 to which, in use, in a loaded condition, the item 12 is attached. The device 10 includes a securing arrangement 22 for securing the item 12 to the load attachment part 16. The hook part 18 includes a relatively low friction contact surface 24 which, in use, contacts and is moved along a load carrying surface 26 of the vehicle load carrying space 14.

20 In this specification, the term “relatively low friction surface” is used to denote a surface which because of its shape and/or surface finish is easier to move across the load carrying surface 26 than would otherwise be the case. Thus a relatively low friction surface could include a smooth or polished surface which is easier to move than a rough surface; a curved surface which is easier to move than a flat surface; and a rolling surface which is easier to move than
25 a non-rolling surface.

In some embodiments of the invention, the contact surface 24 could be curved.

30 In some embodiments of the invention, the contact surface 24 could, in use, roll relative to the load attachment part 16.

In the example shown, the hook part 18 includes a pair of the contact surfaces 24, a pair of wheels 32, a pair of rotational mountings 28 and a pair of hook part members 60. Each wheel 32 is mounted to one of the hook part members 60, which are spaced apart, by one of the rotational mountings 28.

5 Each of the wheels 32 comprises one of the contact surfaces 24.

The rotational mountings 28 mount the wheels 32 for rotation around a common wheel axis 82.

10 The hook part 18 and the load attachment part 16 define a hook space 70 therebetween.

The load attachment part 16 comprises a pair of substantially straight, parallel, spaced apart, longitudinally extending load attachment part members

15 54.

The load attachment part 16 has a first end 50 and a second end 52.

In one example, at the first end 50 of the load attachment part 16, each

20 of the load attachment part members 54 could be connected to one of the hook part members 60 by a connector part 56, which comprises a substantially 90° bend.

In the example shown, the device 10 includes a pair of frame members

25 64, each of which is in the form of a tube and formed of a metal such as mild steel. Each frame member 64 is formed integrally and comprises one of the load attachment part members 54, one of the 90° bend connector parts 56 and one of the hook part members 60.

30 The securing arrangement 22 comprises a pair of flexible strap members 34, each of which extends substantially from a mid-region of a different one of the load attachment part members 54. The securing arrangement 22 includes a releasable fastening 36, which is movable between an open condition in

which the item 12 can be moved towards or away from the load attachment surface 20 and a fastened condition in which the item 12 cannot be moved towards or away from the load attachment surface 20.

5 The releasable fastening 36 could comprise any from the group containing hook and loop/fleece material, a ratchet fastening, a buckle, a prong buckle, a roll pin buckle, a quick release buckle, a cam buckle, a slide buckle.

10 In the example shown, the releasable fastening 36 comprises hook and loop material 74 and a ring 84.

15 Each strap member 34 includes a fixed end 34A fastened to one of the load attachment part members 54 and a free end 34B. The ring 84 is located at a first one of the free ends 34B'. At or towards a second of the free ends 34B'' are located, on one side of the respective strap member 34, an area of hook material 74A and an area of loop material 74B.

20 The or each load attachment surface 20 is directed in a first direction 66. The hook part 18 extends from the load attachment part 16 in a second direction 68, which is an opposite direction to the first direction 66.

25 The load attachment part 16 includes a cushioning 38 for contact with the item 12. The load attachment surfaces 20 comprise part of surfaces of the cushioning 38.

30 In the example shown, the cushioning 38 includes a cushioning layer 38A provided in tubular form around part of the load attachment part members 54. In Fig. 1, only one of the load attachment part members 54 is shown with the layer 38A for the purposes of illustration. In practice, each of the load attachment part members 54 has a cushioning layer 38A thereon.

The load attachment part 16 is substantially planar. The load attachment part 16 has a length 40 and a width 42. The load attachment part 16 defines a load space 44. In Figs. 1 and 2 the dashed lines represent the load space 44.

5 In an unloaded condition, in which the item 12 has not been located in the load space 44, the load space 44 is substantially free of obstruction. The load space 44 has a length 46 and a width 48. The load space length 46 is at least as long as the load attachment part length 40 and the load space width 48 is at least as wide as the load attachment part width 42.

10

In the loaded condition, the item 12 is located in the load space 44, against or on the load attachment part 16.

15

The load space 44 extends beyond one or both ends 50, 52 of the load attachment part 16.

20

The hook part 18 extends from the load attachment part 16 on an opposite side of the load attachment part 16 to the load space 44, from a location at or towards the first end 50 of the load attachment part 16.

At a second end 52, each of the load attachment part members 54 is plain ended.

25

The load attachment part 16 includes a bracing member 58, which extends between the load attachment part members 54. The cushioning 38 could include a cushioning pad 38B located on the bracing member 58.

30

The hook part 18 includes a bracing member 62, which extends between the hook part members 60.

In the example shown, the device 10 is a mobility scooter lifting device. The item 12 is a mobility scooter 76.

In use

Figs. 3A to 3C show steps in the use of the lifting device 10 in lifting the item 12 into and out of the vehicle load carrying space 14.

5

In one example, the item 12 is a mobility scooter 76 which, for transportation, is in a folded condition.

Initially, the item 12 is located on a ground surface 78, alongside a vehicle 80. The vehicle 80 comprises the load carrying surface 26 and defines the load carrying space 14, which could be a space in a trunk, a boot or on a load bed of a pick-up, truck or lorry.

In the example shown, the load carrying surface 26 has an upstanding lip 72 at an outer edge thereof.

The lifting device 10 is located between the item 12 and the vehicle 80, against the item 12 so that the load attachment surfaces 20 of the cushioning 38 contact the item 12 and the item 12 is in the load space 44. The strap members 34 are moved to extend around the item 12. To move the fastening 36 from the open condition to the fastened condition, the second free end 34B'' is passed through the ring 84 and looped back on itself so that the area of hook material 74A engages the area of loop material 74B. In the fastened condition, the lifting device 10 is held firmly and securely against the item 12.

25

In locating the lifting device 10 against the item 12 it will be observed that the lifting device 10 itself is not located on the ground surface 78, but spaced upwardly therefrom. Ideally the lifting device 10 is located against the item 12 so that the hook part 18 locates at least partially over the load carrying surface 26 in the load carrying space 14, with the wheels 32 inside the load carrying space beyond the lip 72 as shown in Fig. 3A, and the lip 72 is located in the hook space 70 between the hook part 18 and the load attachment part 16.

30

Advantageously, the planar load attachment part 16 and the unobstructed load space 44 permit the lifting device 10 to be located against the item 12 at any convenient location along the length of the item 12. For example, in the case of a shorter item, the lifting device 10 could be located in an upper region of the item 12, and in the case of a longer item, the lifting device 10 could be located in a mid or lower region of the item 12.

The item 12 is then tilted until the contact surfaces 24 of the wheels 32 contact the load carrying surface 26 and a lower end of the item 12 is then lifted, as indicated by arrow A in Fig. 3A, pivoting the combined item 12 and lifting device 10 around the wheel axis 82, to arrive at the position shown in Fig. 3B, with the item 12 lifted clear of the ground surface 78.

Advantageously, the support of one end of the item 12 by the lifting device 10 and the provision of a fulcrum (provided by the wheel axis 82) provides a mechanical advantage and reduces the effort required to lift the item 12.

The hook part 18 and the hook space 70 permit the device 10 and the item 12 to be easily lifted over the lip 70.

The combined item 12 and lifting device 10 are then moved further into the load carrying space 14 and along the load carrying surface 26 as indicated by arrow B by pushing the item 12 so that the wheels 32 rotate, and the contact surfaces 24 roll along the load carrying surface 26. The rolling contact surfaces 24 of the wheels 32 are relatively low in friction, facilitating the movement of the combined item 12 and lifting device 10.

When the item 12 is fully in the load carrying space 14, the lower end of the item 12 can be lowered to the load carrying surface 26 as shown in Fig. 3C. The combined item 12 and lifting device 10 in the fastened condition can then be secured to the load carrying surface 26 and transported. On arrival at a

destination, the combined item 12 and lifting device 10 can be unloaded from the vehicle 80 by reversing the above steps.

5 Alternatively, when the item 12 is fully in the load carrying space 14, the fastening 36 could be moved to the open condition, permitting the lifting device 10 to be detached from the item 12 during transportation.

10 There is thus provided a lifting device which is simple to manufacture and use. The simplicity of construction helps keep weight to a minimum, a key consideration for a lifting device which itself must be lifted.

It is a feature of the invention that the device 10 can be relatively small relative to the item 12 and only needs to be attached to one end of the item 12. Again this feature permits a simple and lightweight construction.

15

Other Modifications

20 Various other modifications could be made without departing from the scope of the invention. The lifting device and the various components thereof could be of any suitable size and shape, and could be formed of any suitable material (within the scope of the specific definitions herein).

25 The load attachment part and the hook part could be formed, for example, of mild steel, aluminium, galvanised mild steel or stainless steel.

The connector part 56 could comprise a different angle bend, for example, 45°.

30 The securing arrangement 22 could include any suitable number of strap members 34.

The contact surface 24 could be a stationery surface, which could be curved eg a surface of a skid. The contact surface 24 could be a surface of a

single, relatively wide roller (not shown) which extends between the hook part members 60.

5 The lifting device 10 could be used for any suitable item, and for lifting onto any suitable load carrying surface.

10 In some examples, the size and shape of the device 10 could be bespoke to the item 12. For example, the load attachment part members 54 and/or the load attachment part bracing member 58 could include formations (not shown) which engage with or accommodate features of the item 12.

15 There is thus provided a lifting device 10 with a number of advantages over conventional arrangements. In particular, the device 10 is simple and lightweight in construction, does not add much weight to the item 12 being lifted and can accommodate a variety of different item sizes. The device 10 is easily attached to and detached from the item 12. The device 10 provides a fulcrum (the wheel axis 82) for the load, providing mechanical advantage and reducing the effort required to lift the item 12.

Claims

1. A lifting device for lifting a relatively heavy and/or bulky item such as a mobility scooter into and out of a vehicle load carrying space, the device including a load attachment part and a hook part, the load attachment part comprising one or more load attachment surfaces to which, in use, in a loaded condition, the item is attached, the device including a securing arrangement for securing the item to the load attachment part, the hook part including a relatively low friction contact surface which, in use, contacts and is moved along a load carrying surface of the vehicle load carrying space.
2. A device according to claim 1, in which the contact surface is curved.
3. A device according to claim 2, in which, in use, the contact surface rolls relative to the load attachment part.
4. A device according to claim 3, in which in use, in loading the item into the vehicle load carrying space, the contact surface rolls along the load carrying surface.
5. A device according to claim any of the preceding claims, in which the hook part includes a hook part member.
6. A device according to claim 5 when dependent on claims 3 or 4, in which the hook part includes a rotational mounting, which rotationally mounts the contact surface to the hook part member.
7. A device according to claim 6, in which the contact surface is a surface of a roller.
8. A device according to claim 7, in which the roller is a wheel.
9. A device according to any of claims 6 to 8 when dependent on claim 5, in which the hook part comprises a pair of spaced apart contact surfaces, a

pair of the rotational mountings and a pair of the hook part members, and each contact surface is mounted to one of the hook part members by one of the rotational mountings and in which each of the contact surfaces is mounted for rotation around a common axis.

5

10. A device according to any of the preceding claims, in which the hook part and the load attachment part define a hook space therebetween, in which, in use, a vehicle edge/lip is receivable.

10 11. A device according to any of the preceding claims, in which the securing arrangement comprises a pair of flexible strap members, each of which extends from the load attachment part and which together, in use, in the loaded condition, extend around the item.

15 12. A device according to claim 11, in which the securing arrangement includes a releasable fastening, which is movable between an open condition in which the item can be moved towards or away from the load attachment surface and a fastened condition in which the item cannot be moved towards or away from the load attachment surface, and the releasable fastening
20 may comprise any from the group containing hook and loop/fleece material, a ratchet fastening, a buckle, a prong buckle, a roll pin buckle, a quick release buckle, a tie-down cam buckle, a slide buckle.

25 13. A device according to any of the preceding claims, in which the or each load attachment surface is directed in a first direction, and the hook part extends from the load attachment part in a second direction, which is an opposite direction to the first direction.

30 14. A device according to any of the preceding claims, in which the load attachment part includes cushioning for contact with the item, and in which the or each load attachment surface comprises part of surfaces of the cushioning.

15. A device according to any of the preceding claims, in which the load attachment part defines a load space, and in which the device is movable between the loaded condition, in which an item is located in the load space, possibly against or on the load attachment part, and an unloaded condition, which the item has not been located in the load space, and, in which, in the unloaded condition, the load space is substantially free of obstruction.

16. A device according to claim 15, in which the load attachment part is substantially planar and in which the load attachment part has a length and a width, and, in which, the load space has a length and a width; and in which the load space length may be at least as long as the load attachment part length; and in which the load space width may be at least as wide as the load attachment part width.

17. A device according to claims 15 or 16, in which the load attachment part includes a first end and a second end, and, in which, the load space extends beyond one or both ends of the load attachment part.

18. A device according to any of the preceding claims, in which the load attachment part includes a first end and a second end, and in which the hook part extends from the load attachment part on an opposite side of the load attachment part to the load space, and may extend from a location at or towards the first end of the load attachment part.

19. A device according to claim 18, in which, at the second end of the load attachment part, the load attachment part is plain ended.

20. A device according to any of the preceding claims, in which the load attachment part comprises a pair of longitudinally extending load attachment part members, each having a first end and a second end; and, in which each of the load attachment part members is, at the first end, connected to one

of the hook part members, possibly by a connector part, which may comprise a substantially 90° bend.

5 21. A device according to claim 20, in which the device includes a pair of frame members, each of which may be in the form of a tube and may be formed of a metal such as mild steel; each frame member comprising one of the load attachment part members, one of the connector parts and one of the hook part members.

10 22. A device according to claims 20 or 21, in which the load attachment part includes one or more bracing members, which may extend between the load attachment part members.

15 23. A device according to any of claims 20 to 22, in which the hook part includes a bracing member, which may extend between the hook part members.

24. A device according to any of the preceding claims, in which the lifting device is a mobility scooter lifting device, for lifting a mobility scooter, which may be in a folded condition during lifting.

20 25. A method of lifting a method of lifting a relatively heavy and/or bulky item such as a mobility scooter into and out of a vehicle load carrying space, the method including providing a lifting device, the device including a load attachment part and a hook part, the load attachment part comprising one
25 or more load attachment surfaces to which, in use, an item is attached, the device including a securing arrangement for securing the item to the load attachment part, the hook part including a relatively low friction contact surface which in use contacts and is moved along a load carrying surface of the vehicle load carrying space.

30



Application No: GB1904804.0

Examiner: Mr Karl Whitfield

Claims searched: 1 to 25

Date of search: 3 September 2020

Patents Act 1977: Search Report under Section 17

Documents considered to be relevant:

Category	Relevant to claims	Identity of document and passage or figure of particular relevance
X	1-8, 10-19 & 24	GB 2552938 A (BAYLIS) fig. 4
X	1-24	CN 203753178 U (QINGDAO) fig. 2

Categories:

X	Document indicating lack of novelty or inventive step	A	Document indicating technological background and/or state of the art.
Y	Document indicating lack of inventive step if combined with one or more other documents of same category.	P	Document published on or after the declared priority date but before the filing date of this invention.
&	Member of the same patent family	E	Patent document published on or after, but with priority date earlier than, the filing date of this application.

Field of Search:

Search of GB, EP, WO & US patent documents classified in the following areas of the UKC^X :

--

Worldwide search of patent documents classified in the following areas of the IPC

A61G; B60S; B62B; B66F

The following online and other databases have been used in the preparation of this search report

WPI, EPODOC

International Classification:

Subclass	Subgroup	Valid From
B66F	0019/00	01/01/2006
A61G	0003/06	01/01/2006
B62B	0001/22	01/01/2006