



US00D736366S

(12) **United States Design Patent**
Picco et al.

(10) **Patent No.:** **US D736,366 S**

(45) **Date of Patent:** **** Aug. 11, 2015**

(54) **HVAC DEVICE**

(71) Applicants: **Michael Picco**, Concord (CA); **Santino Figliomeni**, Nobelton (CA); **Siegi Niedermair**, Concord (CA)

(72) Inventors: **Michael Picco**, Concord (CA); **Santino Figliomeni**, Nobelton (CA); **Siegi Niedermair**, Concord (CA)

(73) Assignee: **PRO-TEC-VENT LTD.**, Ontario (CA)

(**) Term: **14 Years**

(21) Appl. No.: **29/434,689**

(22) Filed: **Oct. 16, 2012**

(51) **LOC (10) Cl.** **23-04**

(52) **U.S. Cl.**
USPC **D23/386**

(58) **Field of Classification Search**
USPC D23/385-395, 397, 370-373, 365, 354, D23/399-403, 421, 499; 454/309, 275-277, 454/284, 287-291, 358-363; 52/302.1, 52/32.07; 285/229, 189, 183, 123.1, 15, 285/114, 110, 424, 197
See application file for complete search history.

(56) **References Cited**

U.S. PATENT DOCUMENTS

D298,053	S	*	10/1988	Waltz et al.	D23/387
D298,276	S	*	10/1988	Butcher	D23/354
D298,853	S	*	12/1988	Waltz et al.	D23/387
D338,713	S	*	8/1993	Cox et al.	D23/328
D362,059	S	*	9/1995	Wojcik	D23/393
D382,049	S	*	8/1997	Trampp	D23/365
5,733,191	A	*	3/1998	Lam et al.	454/290
D393,708	S	*	4/1998	Assadi	D23/388
D394,901	S	*	6/1998	Governale et al.	D23/354
D402,356	S	*	12/1998	Hodge	D23/365
6,234,893	B1	*	5/2001	Meredith	454/289
D449,880	S	*	10/2001	Webb	D23/393
6,506,113	B2	*	1/2003	Berger	454/290
D494,265	S	*	8/2004	Snyder et al.	D23/393
D494,669	S	*	8/2004	Achen	D23/388

D496,992	S	*	10/2004	Lafond	D23/388
D609,800	S	*	2/2010	Chen	D23/385
D618,779	S	*	6/2010	Jenkins	D23/365
8,142,265	B2	*	3/2012	Carter	454/290
8,419,515	B1	*	4/2013	Dillon	454/284

* cited by examiner

Primary Examiner — David Muller

(74) *Attorney, Agent, or Firm* — Blue Filament Law PLLC; Avery N. Goldstein

(57) **CLAIM**

The ornamental design for a HVAC device, as shown and described.

DESCRIPTION

FIG. 1 is a top perspective view of the assembled HVAC device;

FIG. 2 is a front view of the assembled HVAC device of FIG. 1;

FIG. 3 is a rear view of the assembled HVAC device of FIG. 1;

FIG. 4 is a bottom view of the assembled HVAC device of FIG. 1;

FIG. 5 is a right side view of the assembled HVAC device of FIG. 1;

FIG. 6 is a left side view of the assembled HVAC device of FIG. 1;

FIG. 7 is a top view of the assembled HVAC device of FIG. 1;

FIG. 8 is a top perspective view of a base portion of the HVAC device;

FIG. 9 is a bottom perspective view of the base portion of the HVAC device;

FIG. 10 is a top plan view of the base portion of the HVAC device;

FIG. 11 is a bottom plan view of the base portion of the HVAC device;

FIG. 12 is a left side view of the base portion of the HVAC device;

FIG. 13 is a right side view of the base portion of the HVAC device;

FIG. 14 is a front view of the base portion of the HVAC device;

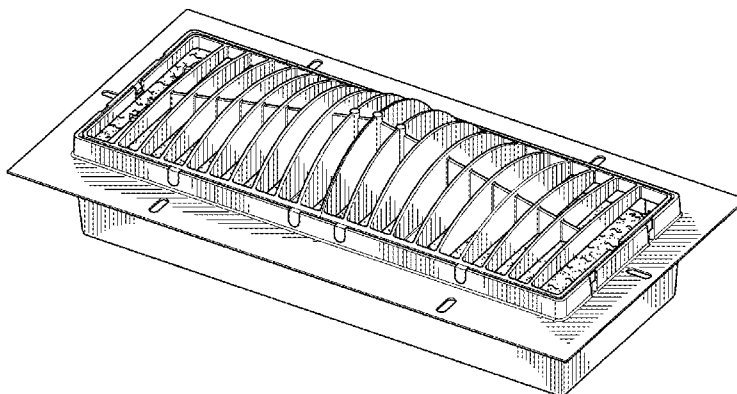

FIG. 15 is a rear view of the base portion of the HVAC device;
FIG. 16 is a top perspective view of a basket portion of the HVAC device;
FIG. 17 is a bottom perspective view of the basket portion of the HVAC device;
FIG. 18 is a bottom plan view of the basket portion of the HVAC device;
FIG. 19 is a top plan view of the basket portion of the HVAC device;
FIG. 20 is a left side view of the basket portion of the HVAC device;
FIG. 21 is a right side view of the basket portion of the HVAC device;
FIG. 22 is a front view of the basket portion of the HVAC device;
FIG. 23 is a rear view of the basket portion of the HVAC device;
FIG. 24 is a bottom perspective view of a grill portion of the HVAC device;
FIG. 25 is a top perspective view of the grill portion of the HVAC device;
FIG. 26 is a top plan view of the grill portion of the HVAC device;
FIG. 27 is a bottom plan view of the grill portion of the HVAC device;
FIG. 28 is a left side view of the grill portion of the HVAC device;
FIG. 29 is a right side view of the grill portion of the HVAC device;
FIG. 30 is a front view of the grill portion of the HVAC device;
FIG. 31 is a rear view of the grill portion of the HVAC device;
FIG. 32 is a top perspective view of a filter portion of the HVAC device, the bottom perspective view being identical;
FIG. 33 is a top plan view of the filter portion of the HVAC device, the bottom plan view being identical;
FIG. 34 is a left side view of the filter portion of the HVAC device, the right side view being identical;
FIG. 35 is a front view of the filter portion of the HVAC device, the rear view being identical;
FIG. 36 is a top perspective view of a reinforcing portion of the HVAC device;
FIG. 37 is a bottom perspective view of the reinforcing portion of the HVAC device;
FIG. 38 is a top plan view of the reinforcing portion of the HVAC device;

FIG. 39 is a bottom plan view of the reinforcing portion of the HVAC device;
FIG. 40 is a left side view of the reinforcing portion of the HVAC device;
FIG. 41 is a right side view of the reinforcing portion of the HVAC device;
FIG. 42 is a front view of the reinforcing portion of the HVAC device;
FIG. 43 is a rear view of the reinforcing portion of the HVAC device;
FIG. 44 is a top perspective view of the basket portion in use with the base portion;
FIG. 45 is a bottom perspective view of the structure of FIG. 44;
FIG. 46 is a top plan view of the structure of FIG. 44;
FIG. 47 is a bottom plan view of the structure of FIG. 44;
FIG. 48 is a left side view of the structure of FIG. 44;
FIG. 49 is a right side view of the structure of FIG. 44;
FIG. 50 is a front view of the structure of FIG. 44;
FIG. 51 is a rear view of the structure of FIG. 44;
FIG. 52 is a top perspective view of the structure of FIG. 44 in use with the filter portion;
FIG. 53 is a bottom perspective view of the structure of FIG. 52;
FIG. 54 is a top plan view of the structure of FIG. 52;
FIG. 55 is a bottom plan view of the structure of FIG. 52;
FIG. 56 is a left side view of the structure of FIG. 52;
FIG. 57 is a right side view of the structure of FIG. 52;
FIG. 58 is a front view of the structure of FIG. 52;
FIG. 59 is a rear view of the structure of FIG. 52;
FIG. 60 is a top perspective view of the grill portion in use with the base portion;
FIG. 61 is a bottom perspective view of the structure of FIG. 60;
FIG. 62 is a top plan view of the structure of FIG. 60;
FIG. 63 is a bottom plan view of the structure of FIG. 60;
FIG. 64 is a left side view of the structure of FIG. 60;
FIG. 65 is a right side view of the structure of FIG. 60;
FIG. 66 is a front view of the structure of FIG. 60; and,
FIG. 67 is a rear view of the structure of FIG. 60.
The views depicted in FIGS. 1-67 comprise a single inventive HVAC device and are shown separately for ease of illustration.

1 Claim, 25 Drawing Sheets

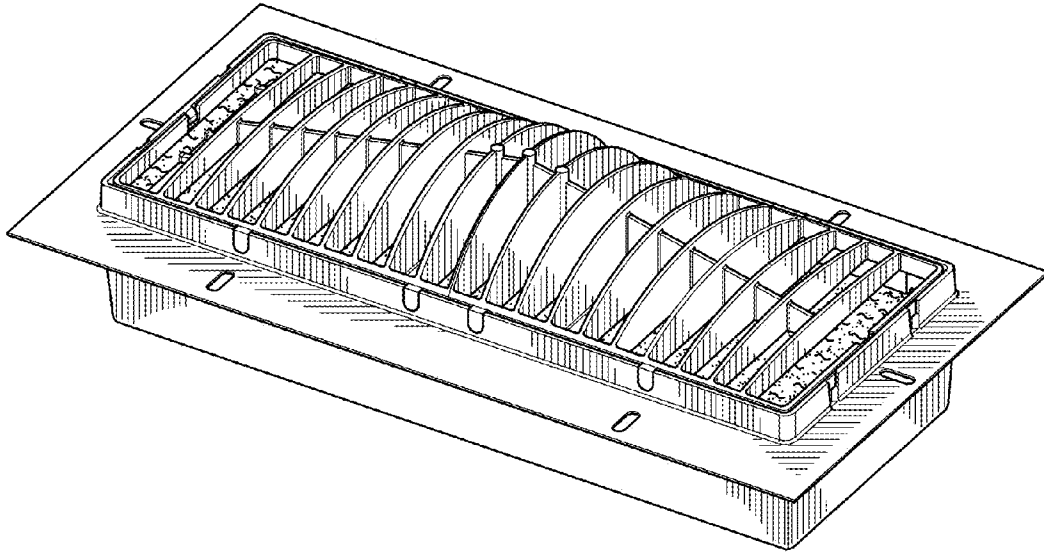

FIG. 1

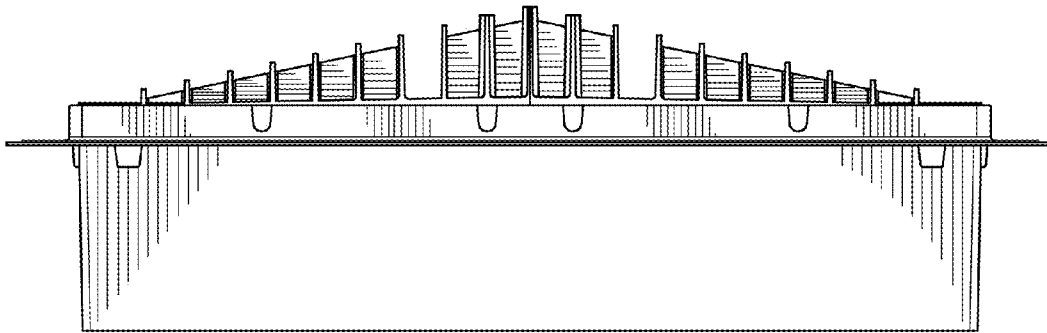

FIG. 2

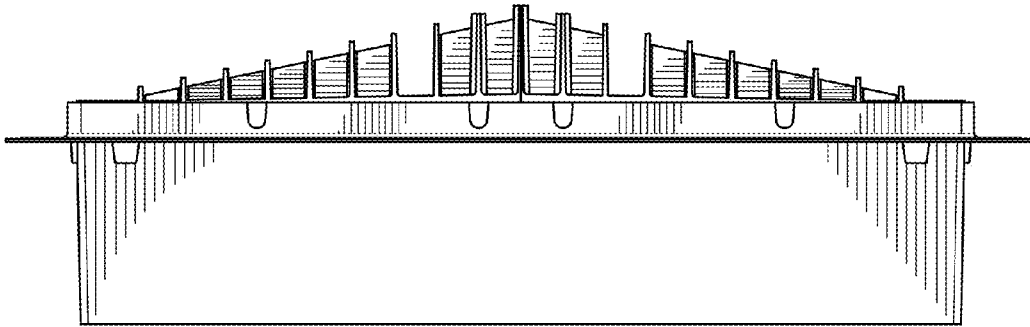

FIG. 3

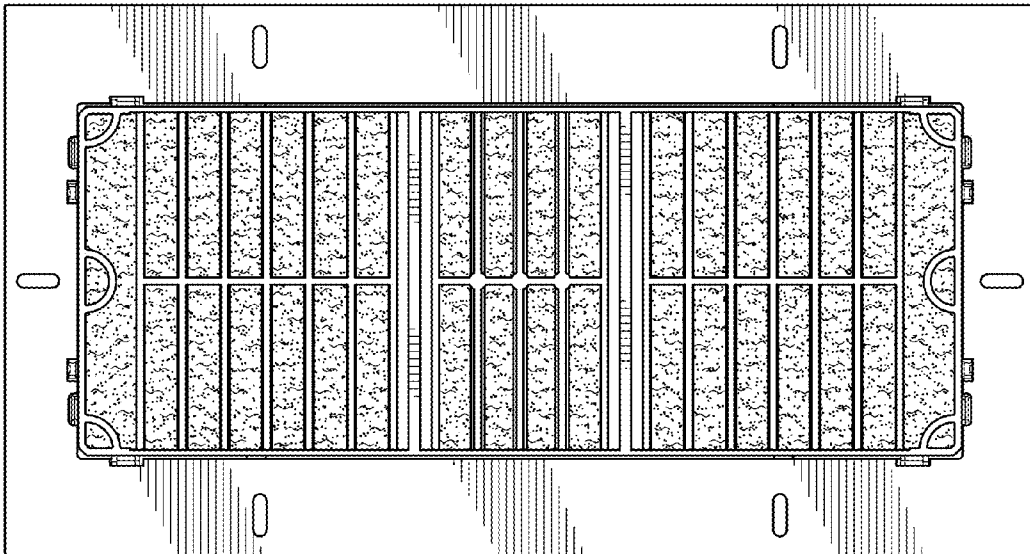

FIG. 4

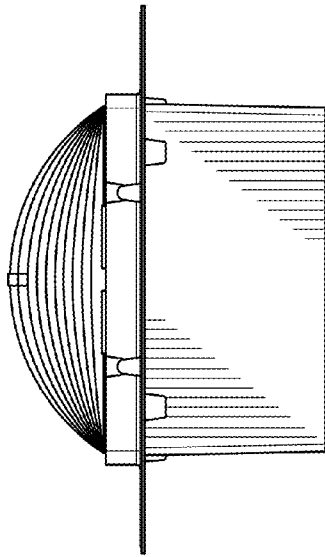

FIG. 5

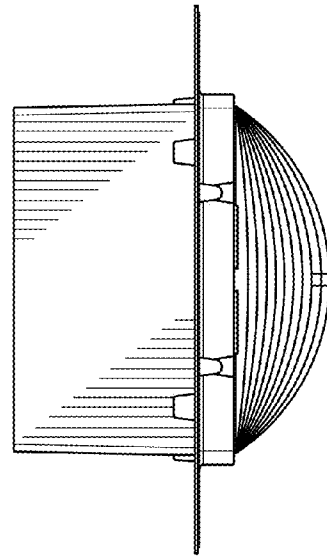

FIG. 6

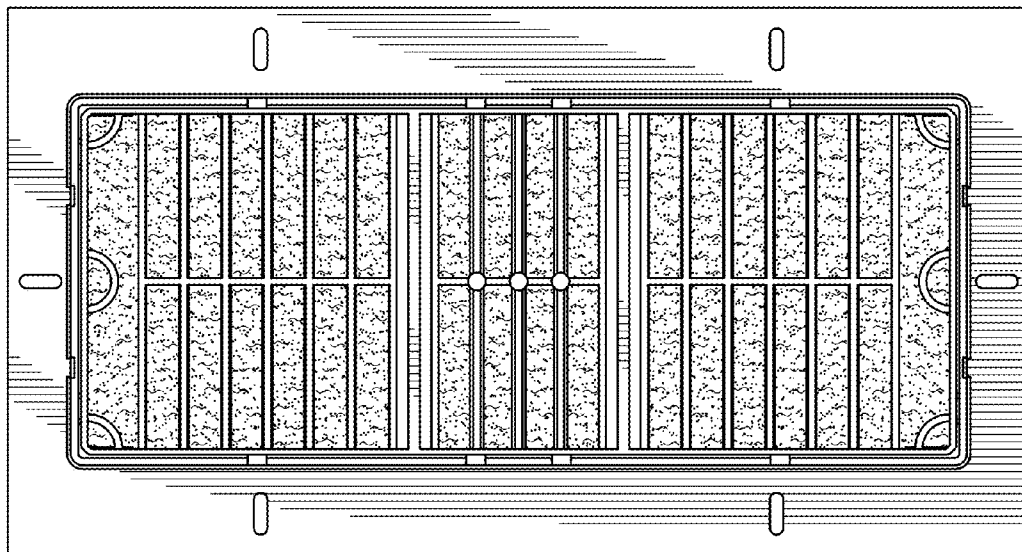

FIG. 7

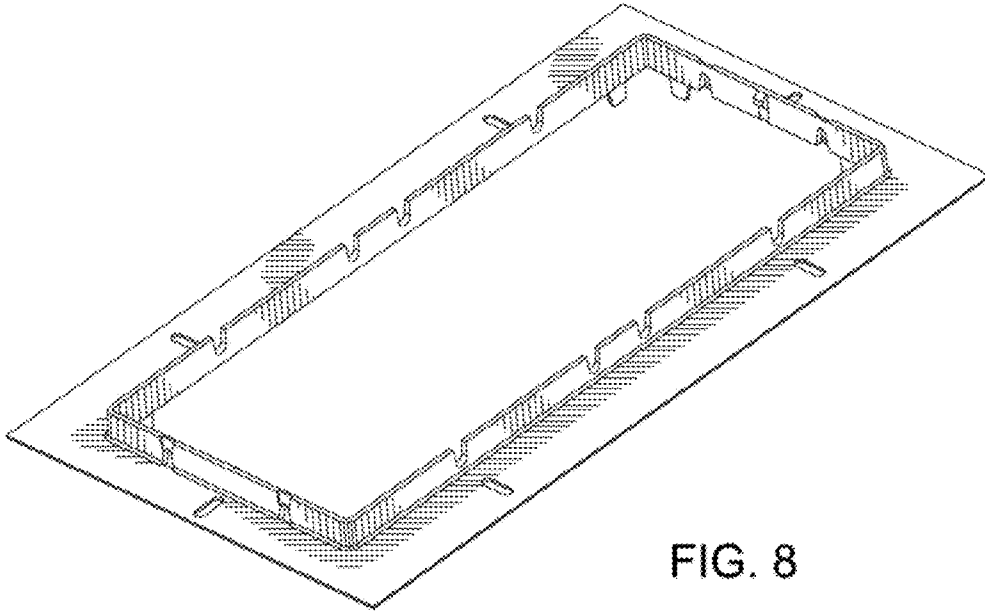

FIG. 8

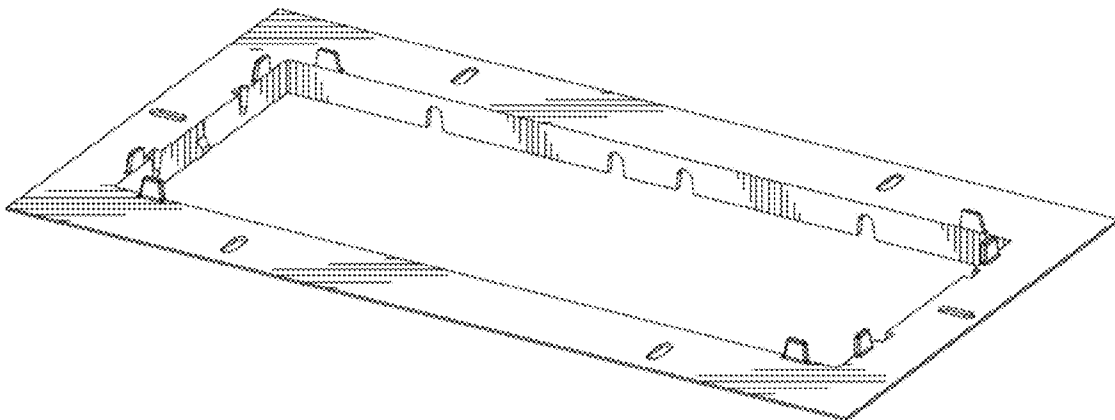

FIG. 9

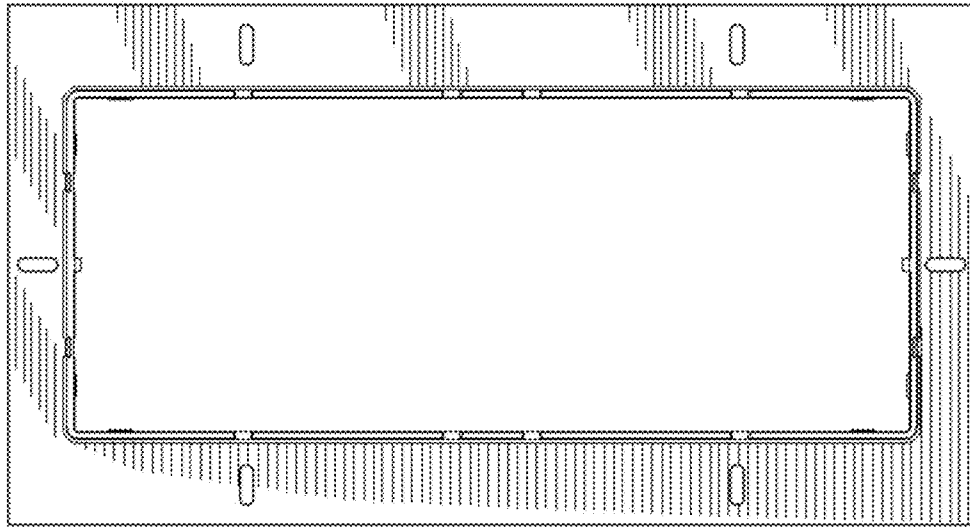

FIG. 10

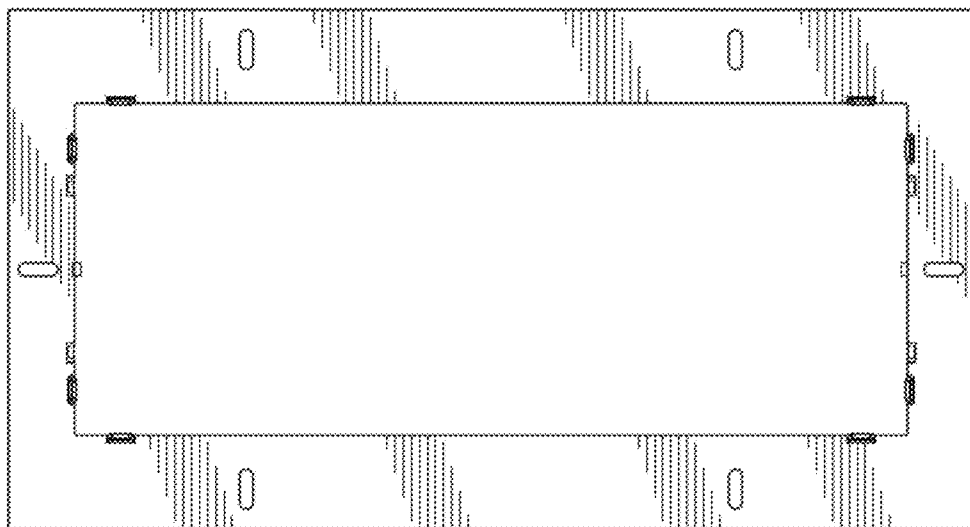

FIG. 11



FIG. 12



FIG. 13



FIG. 14



FIG. 15

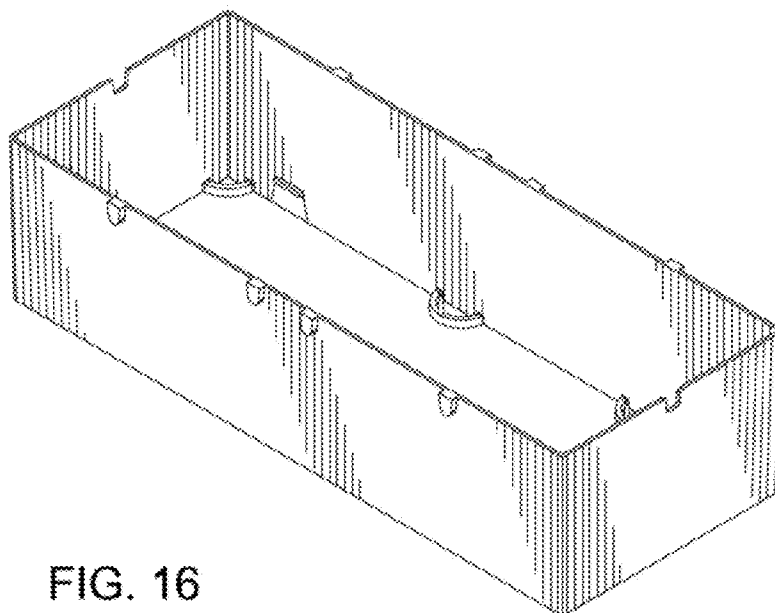

FIG. 16

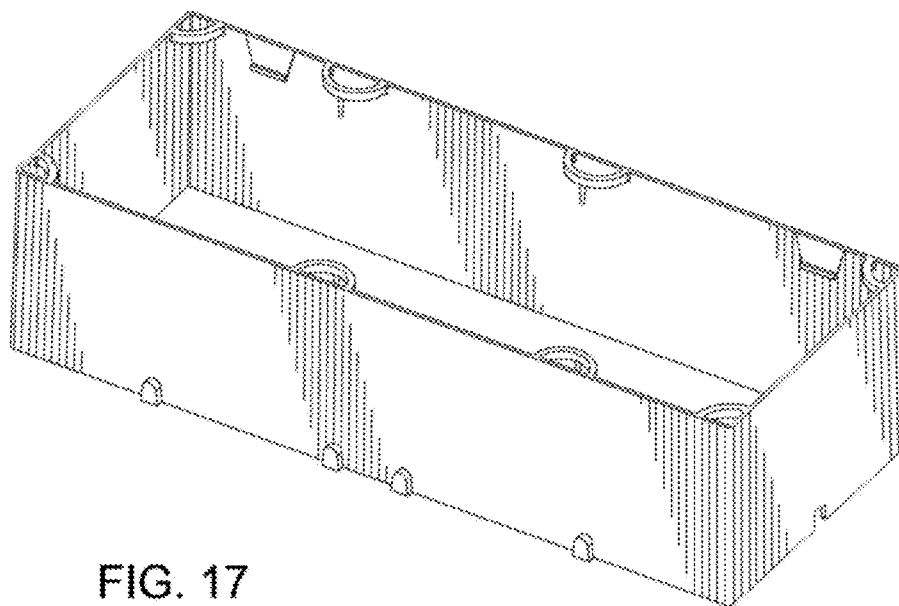

FIG. 17

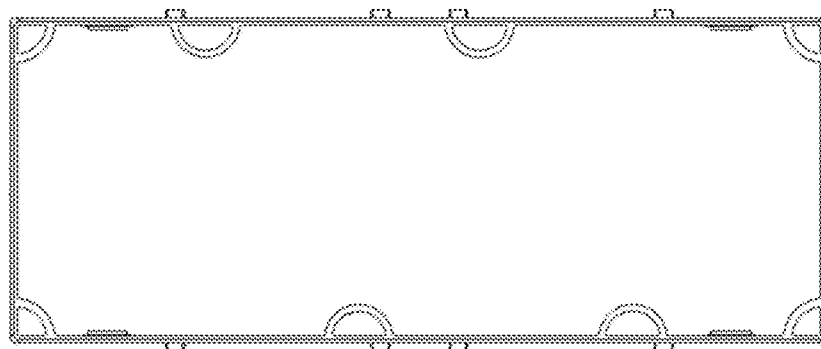

FIG. 18

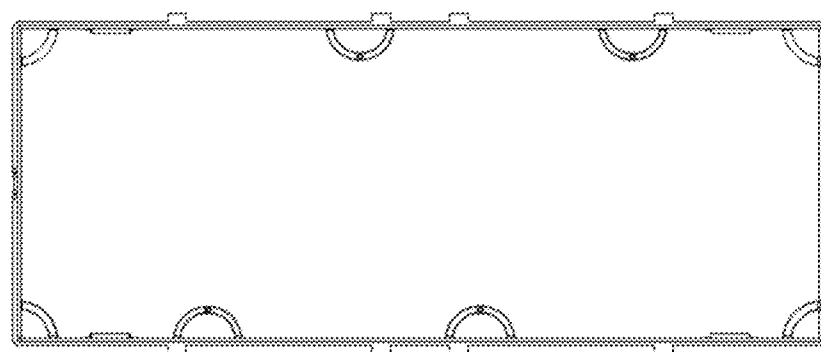

FIG. 19

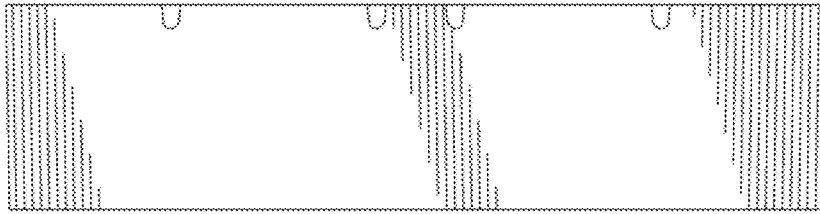

FIG. 20

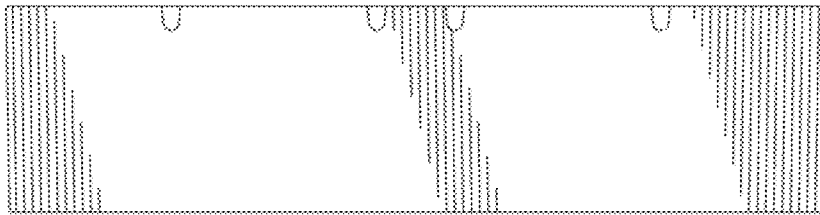

FIG. 21

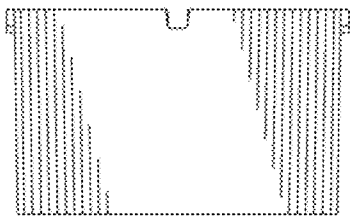

FIG. 22

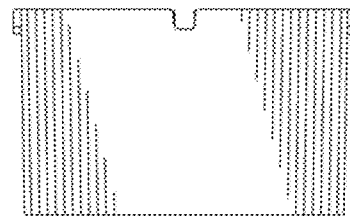

FIG. 23

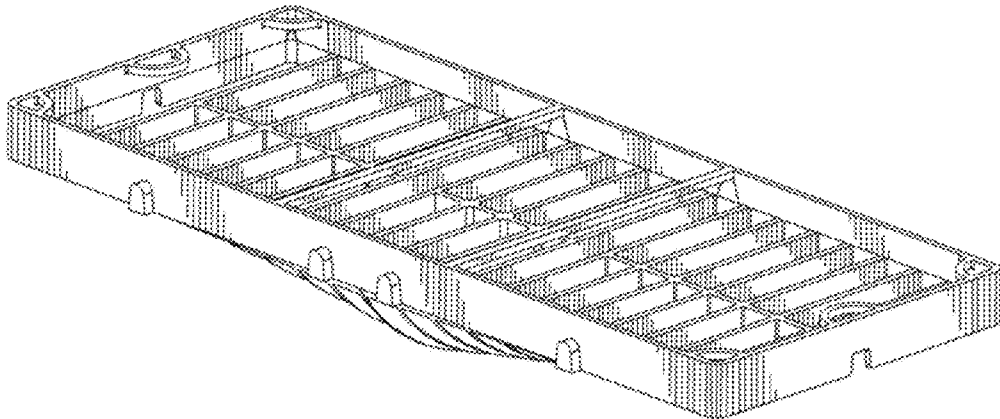

FIG. 24

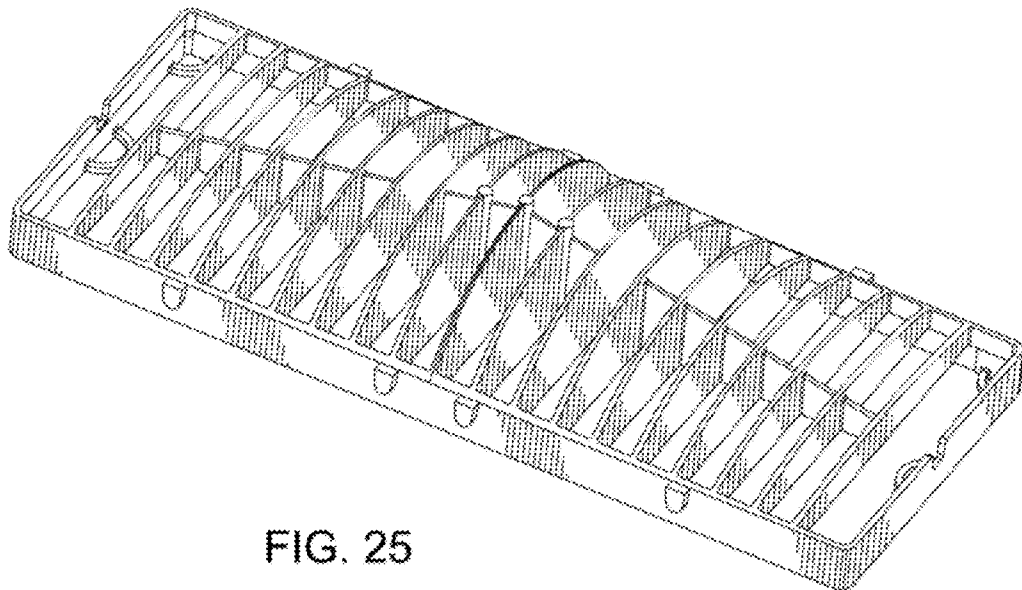

FIG. 25

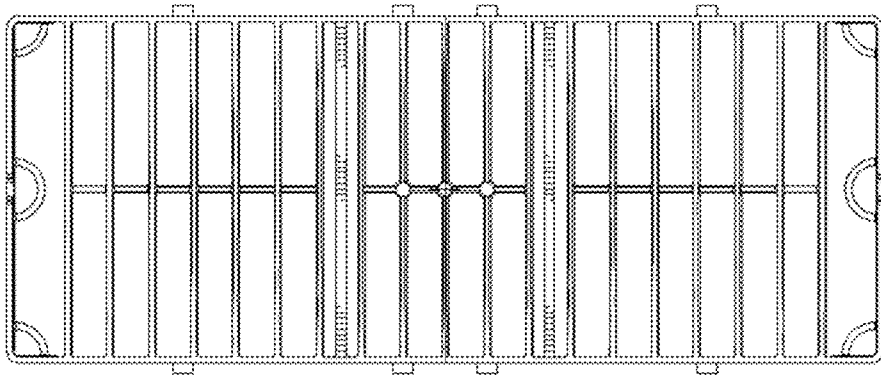

FIG. 26

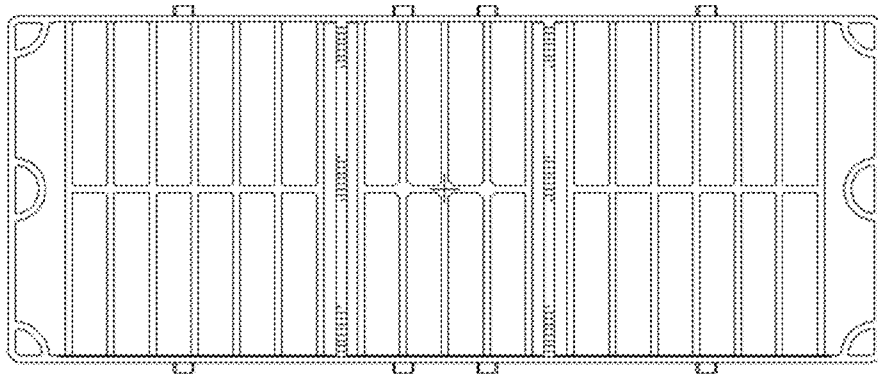

FIG. 27

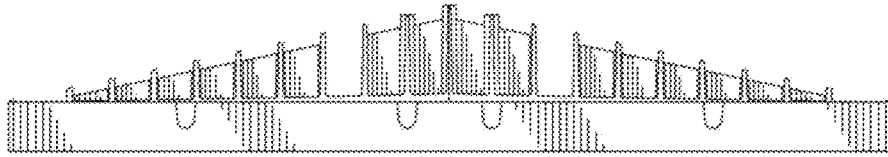

FIG. 28

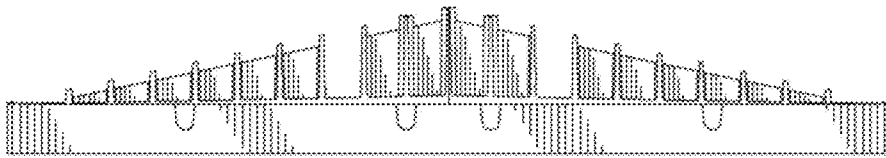

FIG. 29

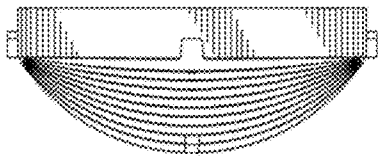

FIG. 30

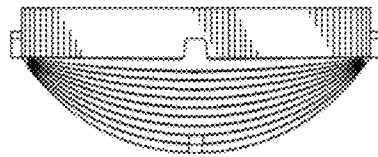

FIG. 31

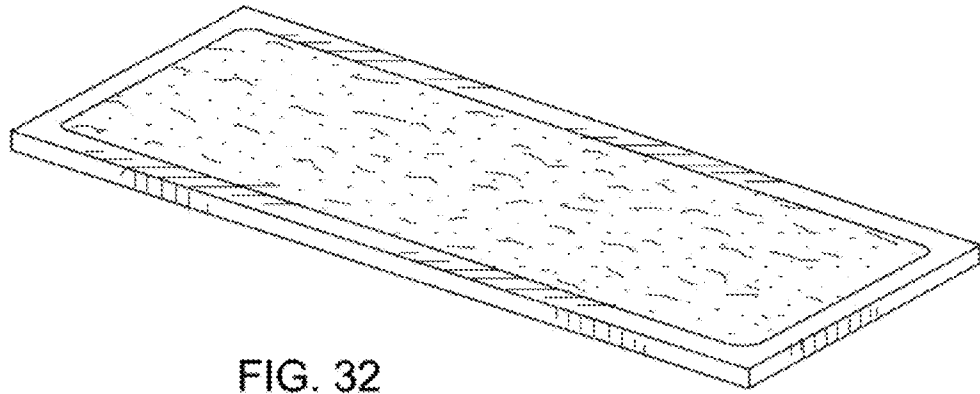

FIG. 32

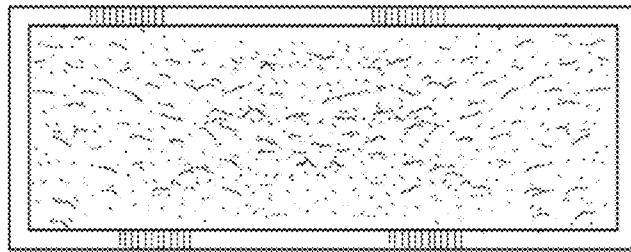

FIG. 33

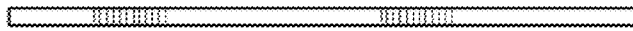

FIG. 34

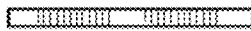

FIG. 35

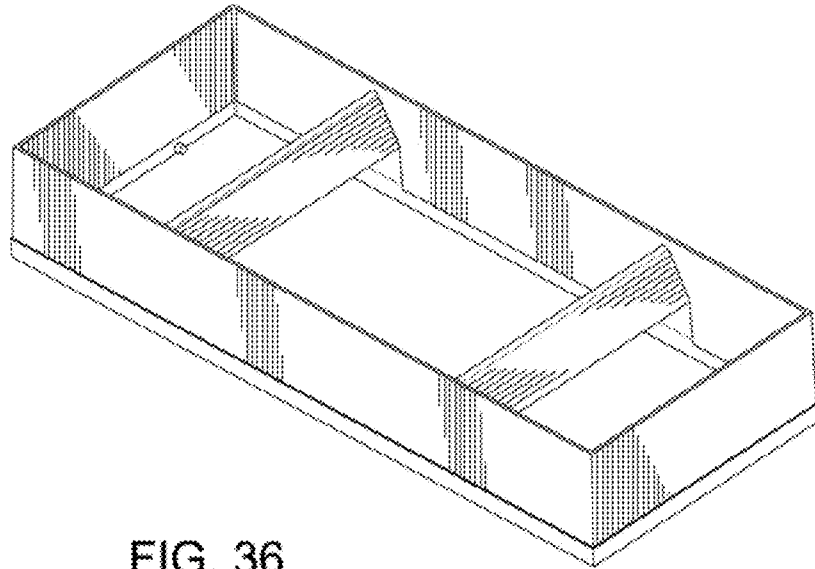

FIG. 36

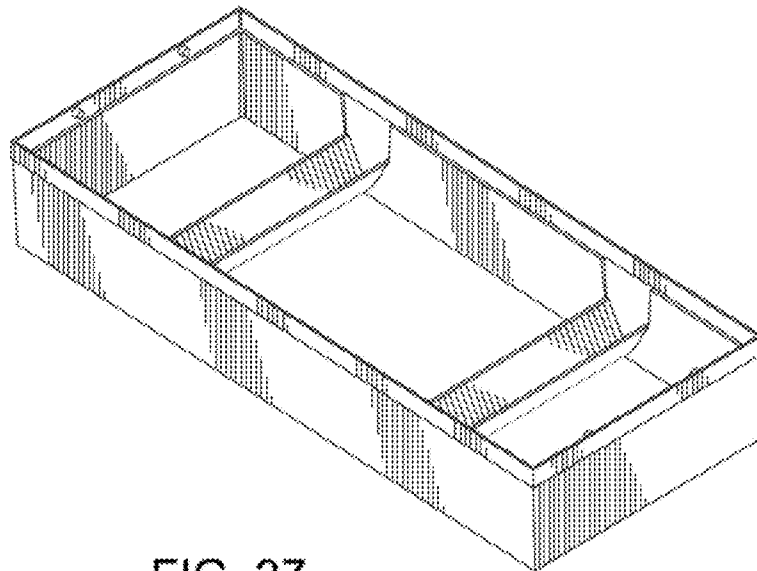

FIG. 37

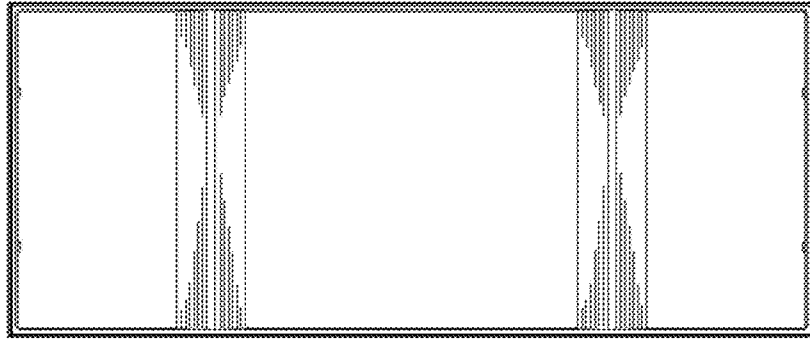

FIG. 38

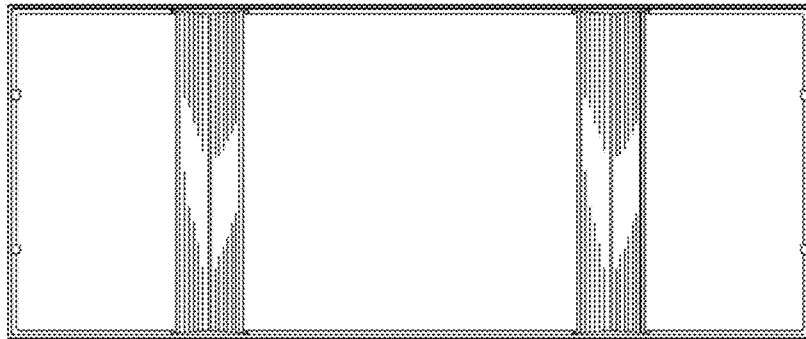

FIG. 39

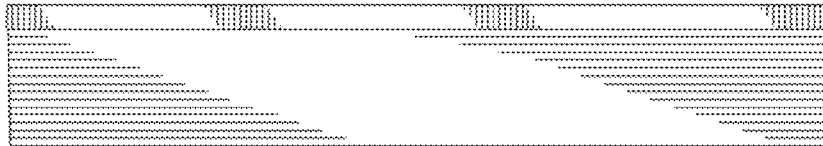

FIG. 40

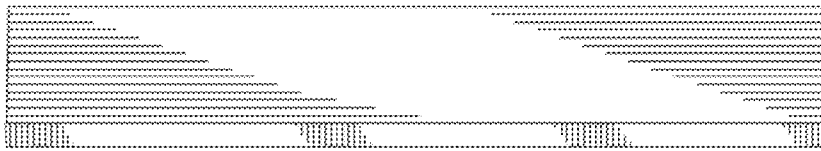

FIG. 41



FIG. 42



FIG. 43

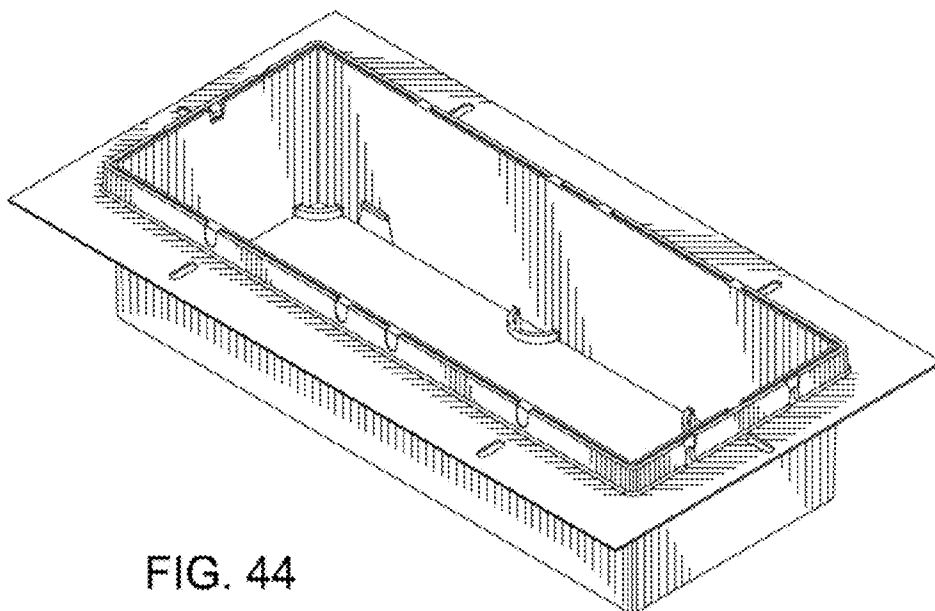

FIG. 44

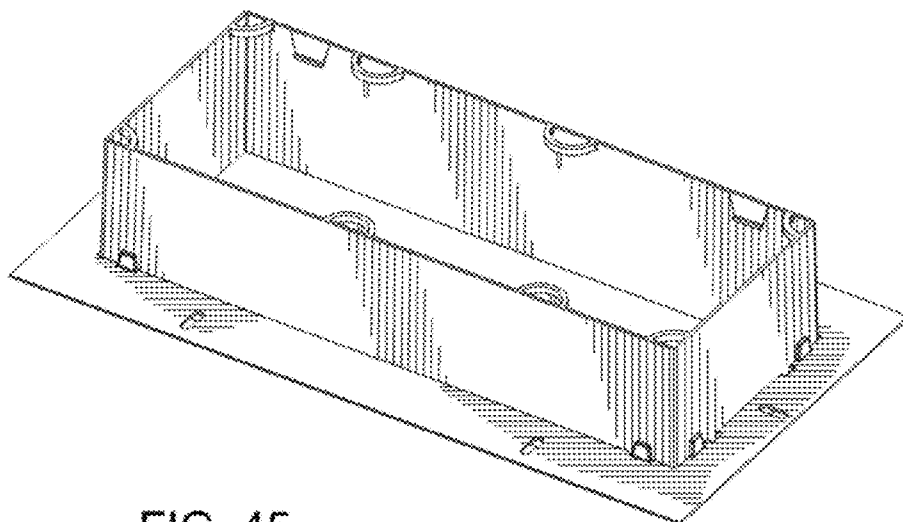

FIG. 45

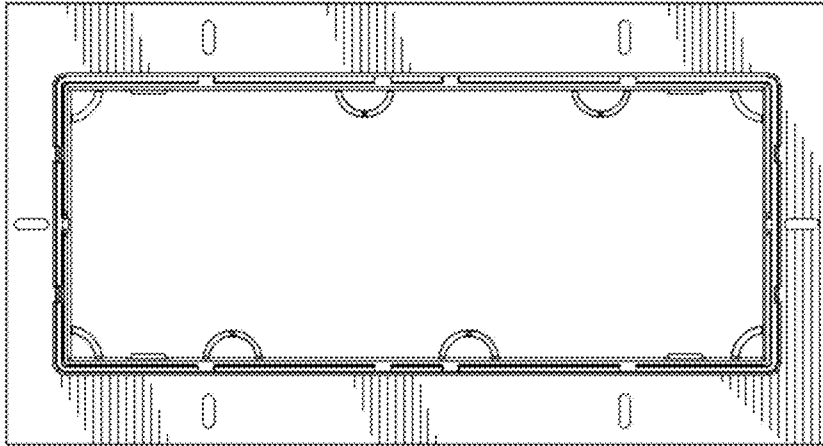

FIG. 46

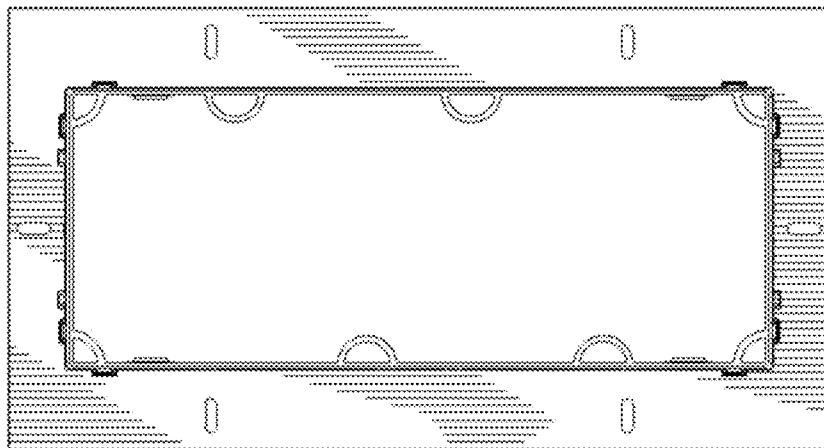

FIG. 47

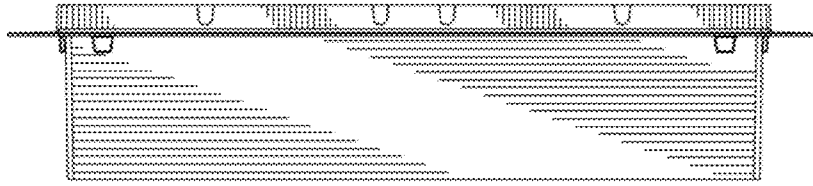

FIG. 48

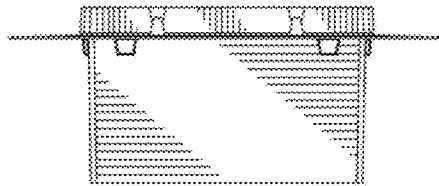

FIG. 49



FIG. 50

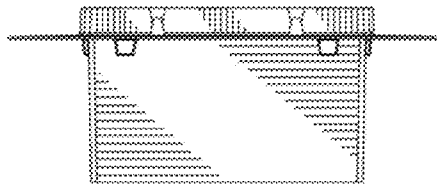

FIG. 51

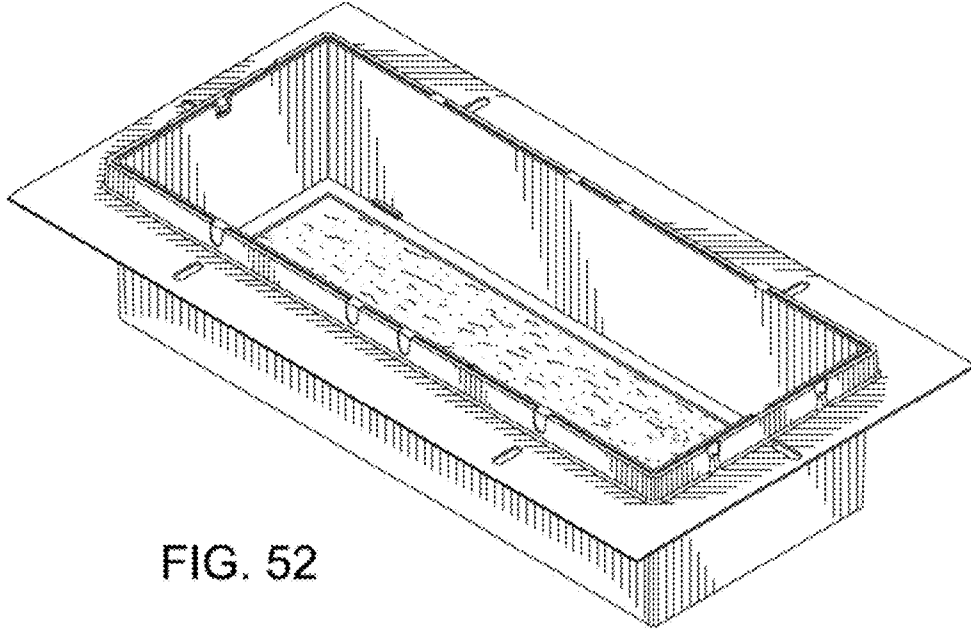

FIG. 52

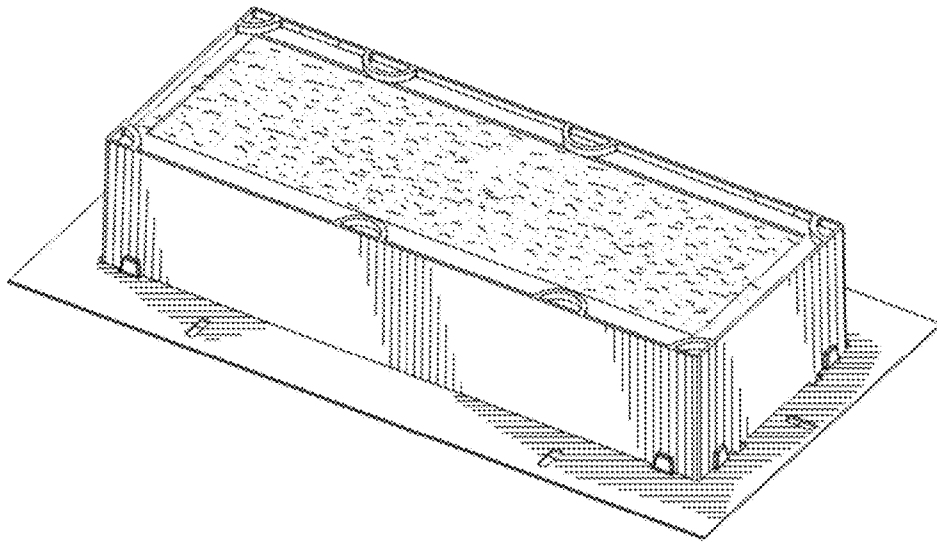

FIG. 53

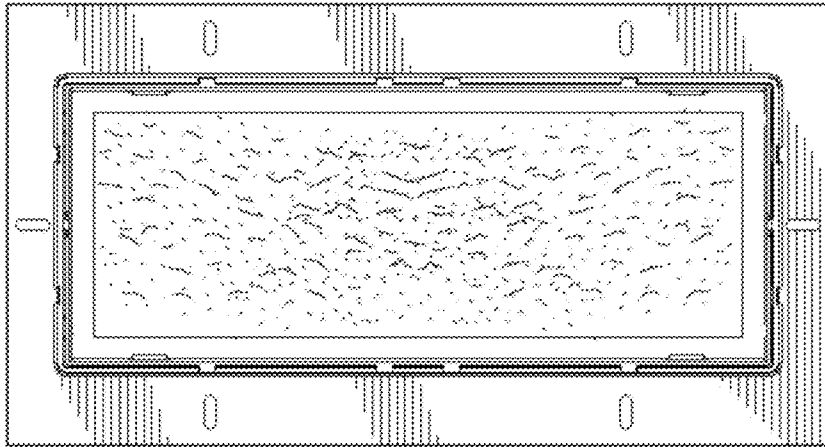

FIG. 54

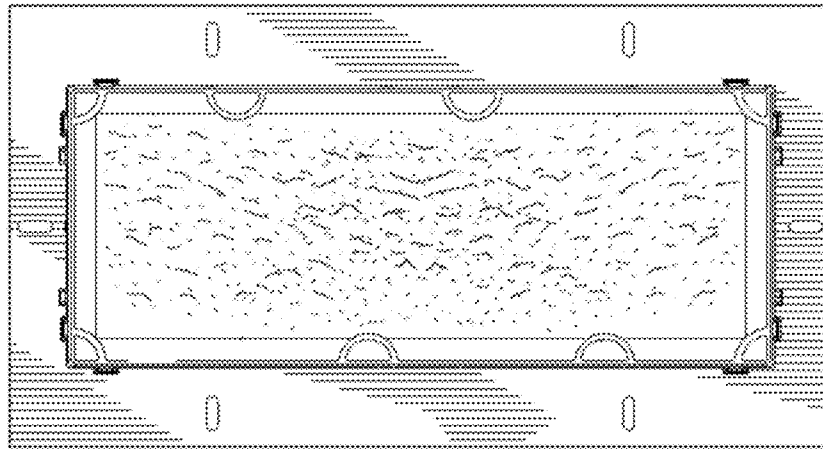

FIG. 55

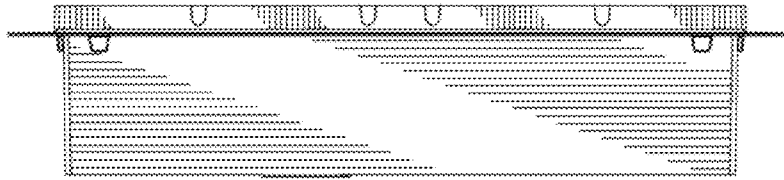

FIG. 56

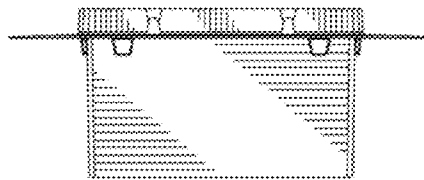

FIG. 57



FIG. 58



FIG. 59

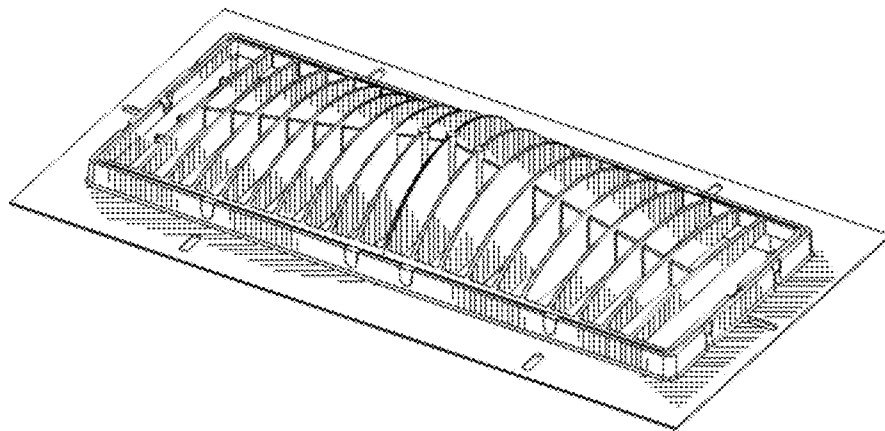

FIG. 60

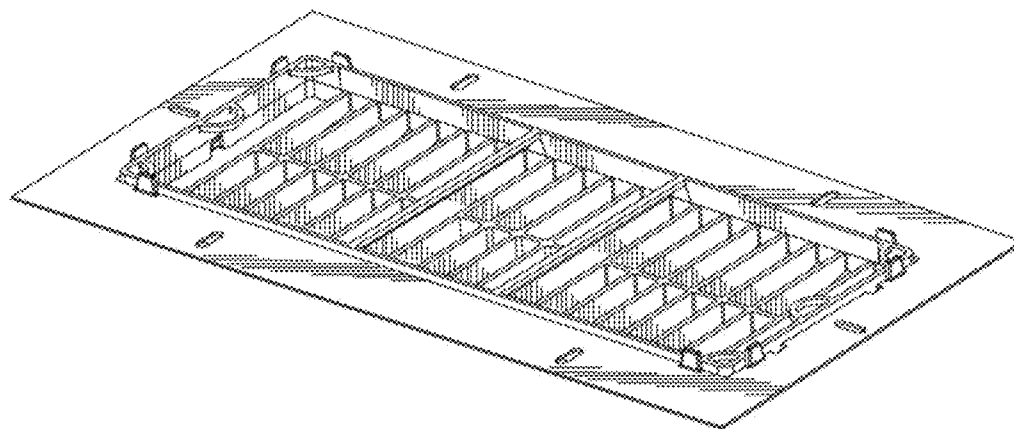

FIG. 61

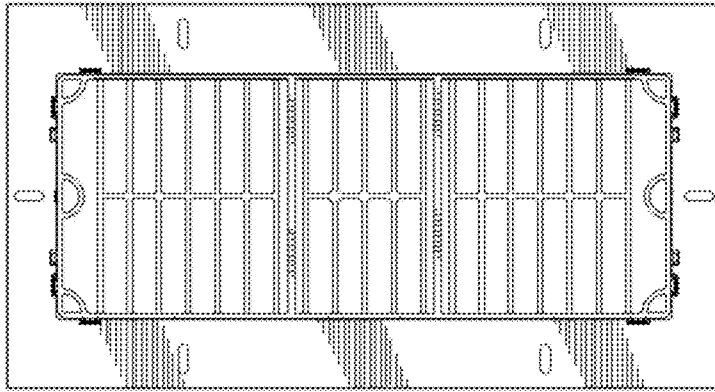

FIG. 62

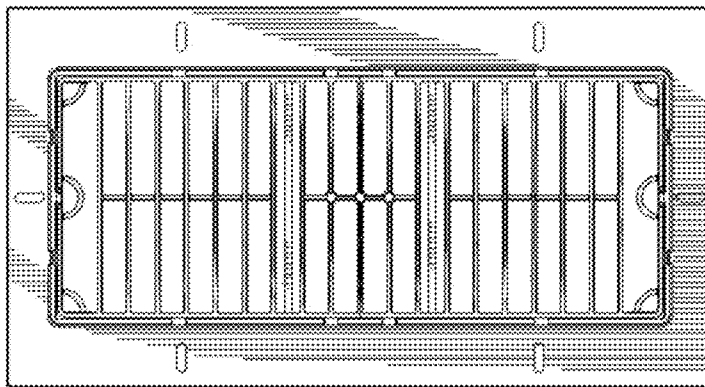

FIG. 63

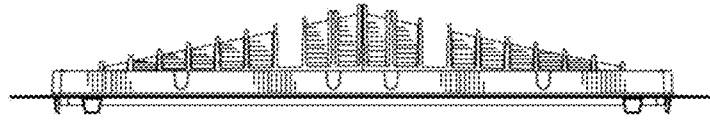

FIG. 64

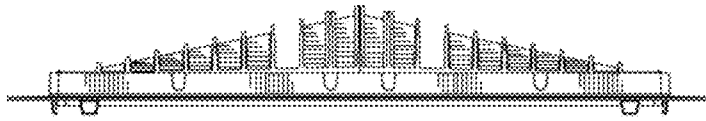

FIG. 65

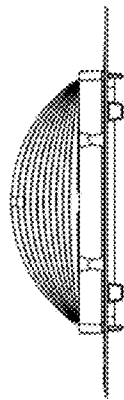

FIG. 66

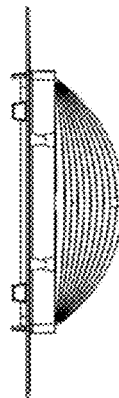

FIG. 67