



US 20040191087A1

(19) **United States**

(12) **Patent Application Publication**
Liu

(10) **Pub. No.: US 2004/0191087 A1**

(43) **Pub. Date: Sep. 30, 2004**

(54) **CEILING FAN WITH BI-DIRECTIONAL ROTATION CONTROL**

(52) **U.S. Cl. 417/326**

(76) **Inventor: Chang-Ming Liu, Taichung City (TW)**

(57) **ABSTRACT**

Correspondence Address:
LADAS & PARRY
224 SOUTH MICHIGAN AVENUE, SUITE
1200
CHICAGO, IL 60604 (US)

A ceiling fan includes a motor having motor coils, blades connected to the motor, a support assembly including a canopy and a hanger rod that is suspended from the canopy and that extends to the motor, a remote fan controller arranged inside the canopy, and a direction control unit connected to the remote fan controller and the motor coils. The direction control unit includes a relay switch circuit arranged in the canopy. The remote fan controller is adapted to receive a control signal transmitted wirelessly by a remote controlling device, and controls actuation of the relay switch circuit in response to the control signal received thereby so as to change direction of current in the motor coils in order to control direction of rotation of the motor.

(21) **Appl. No.: 10/397,607**

(22) **Filed: Mar. 26, 2003**

Publication Classification

(51) **Int. Cl.⁷ F04B 35/00**

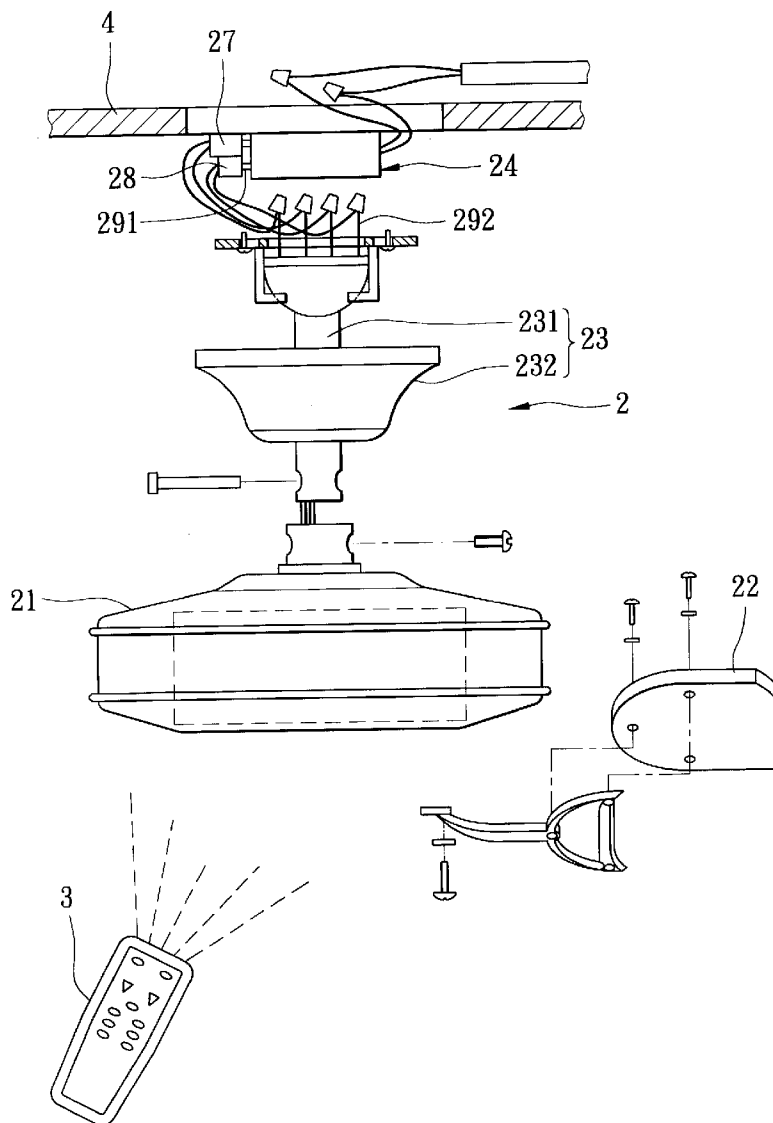

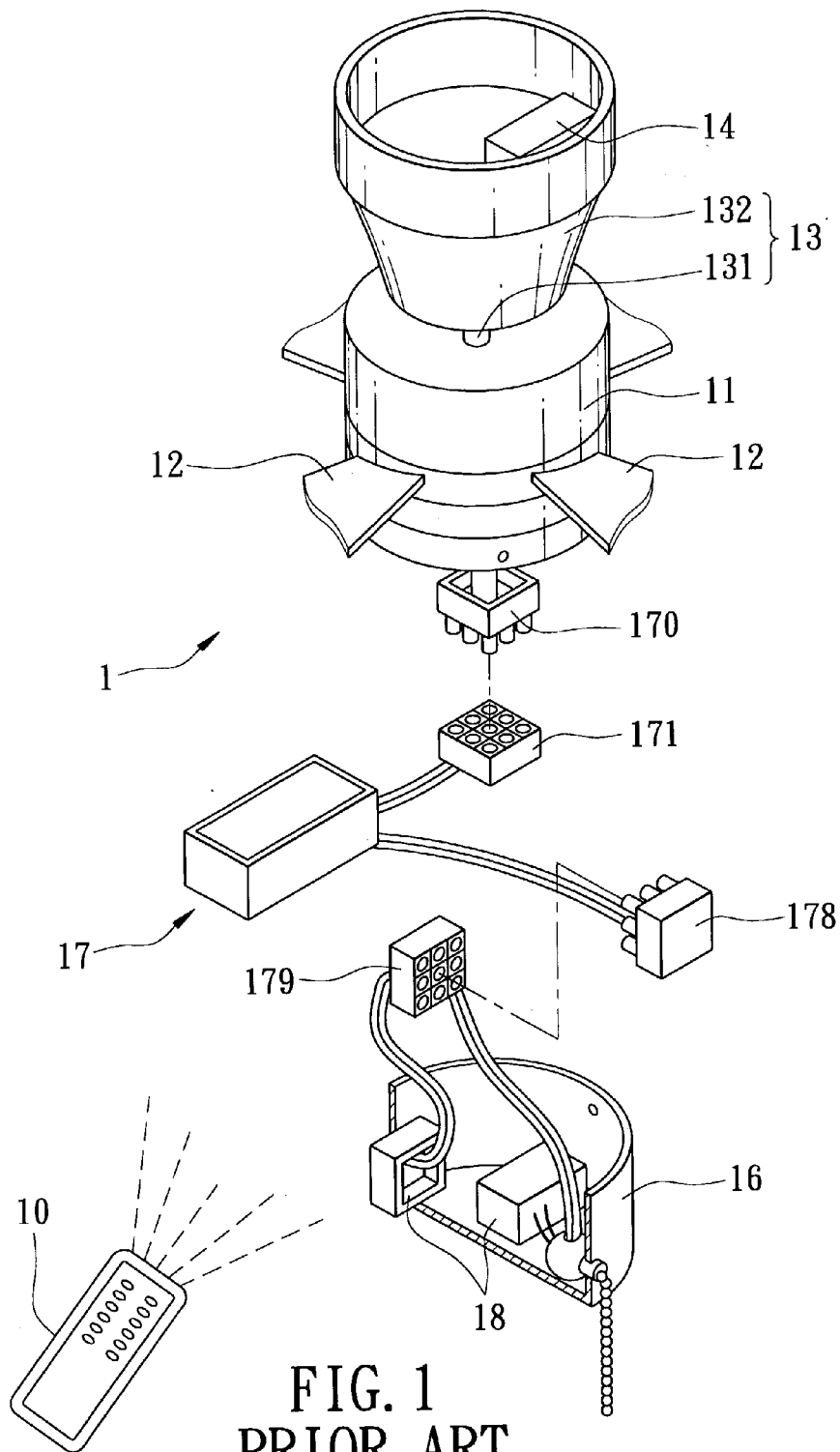

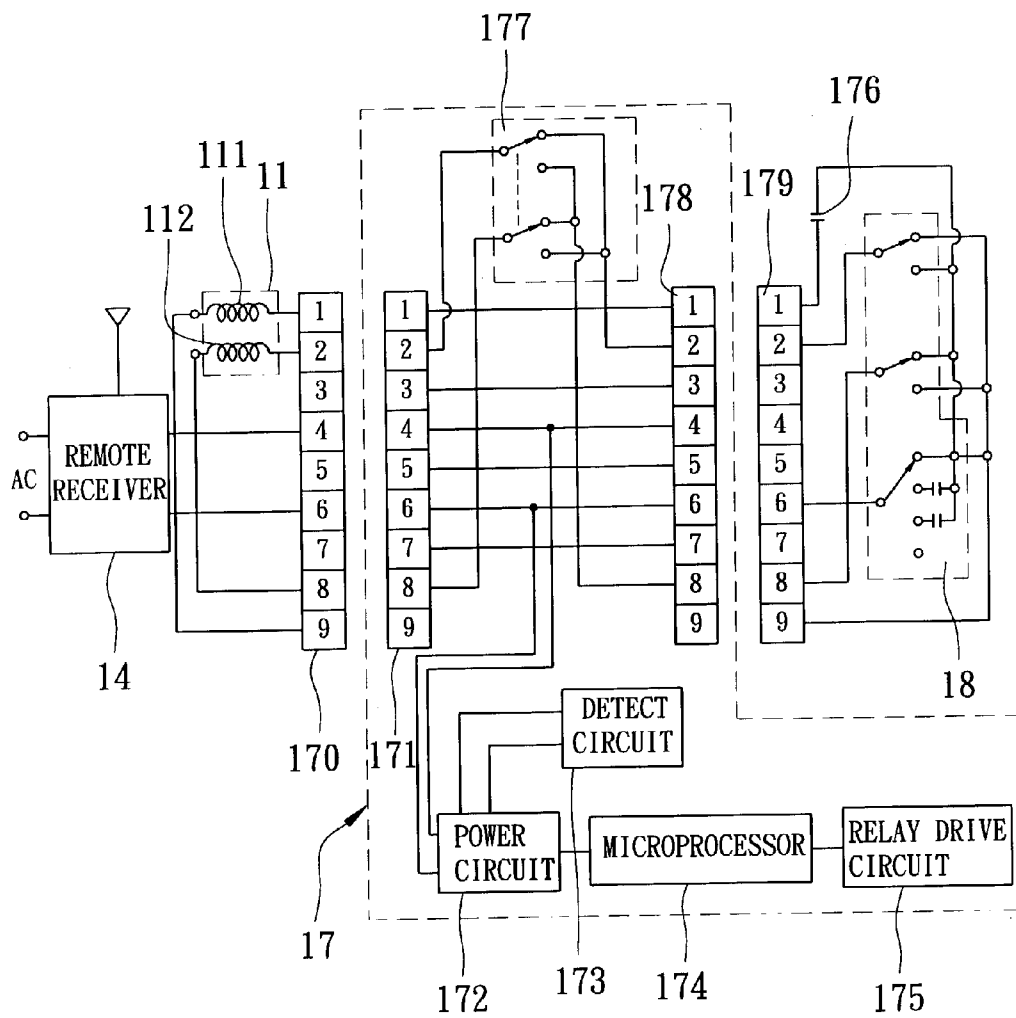

FIG. 2
PRIOR ART

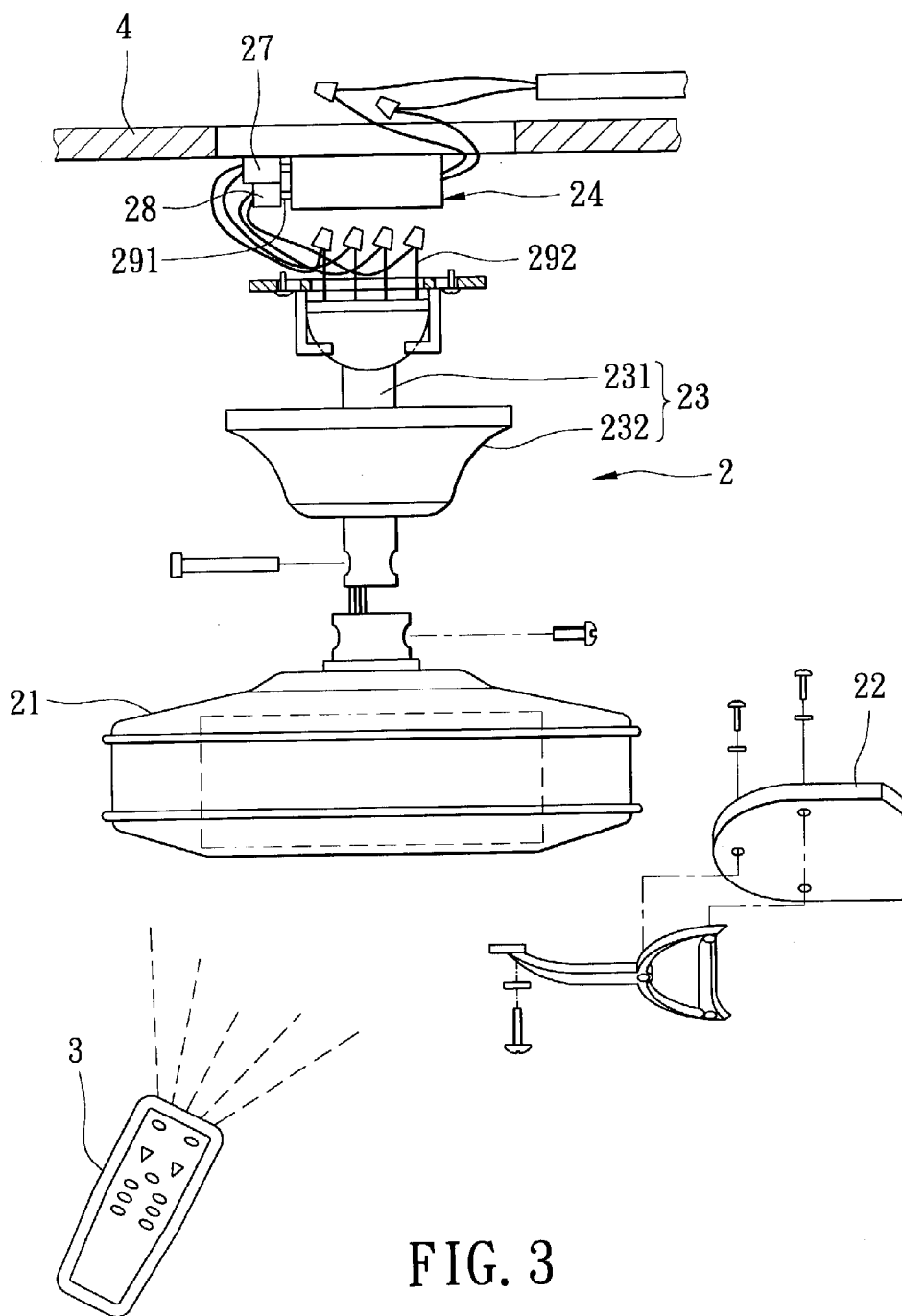

FIG. 3

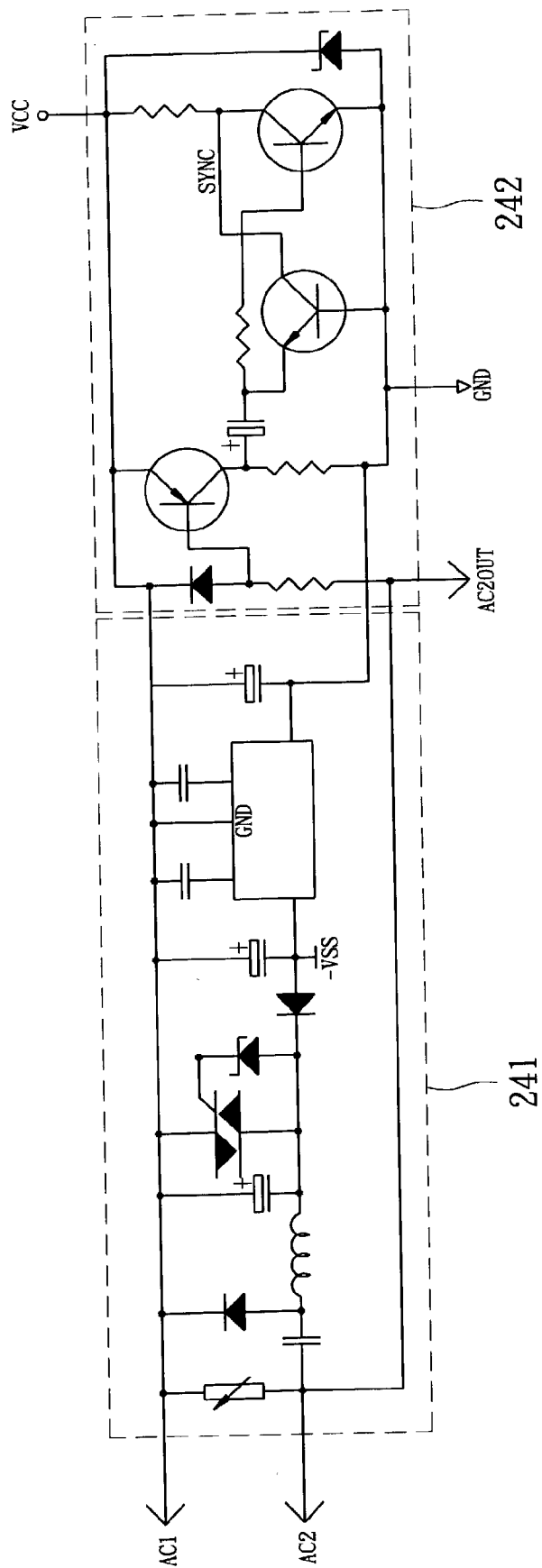

FIG. 5

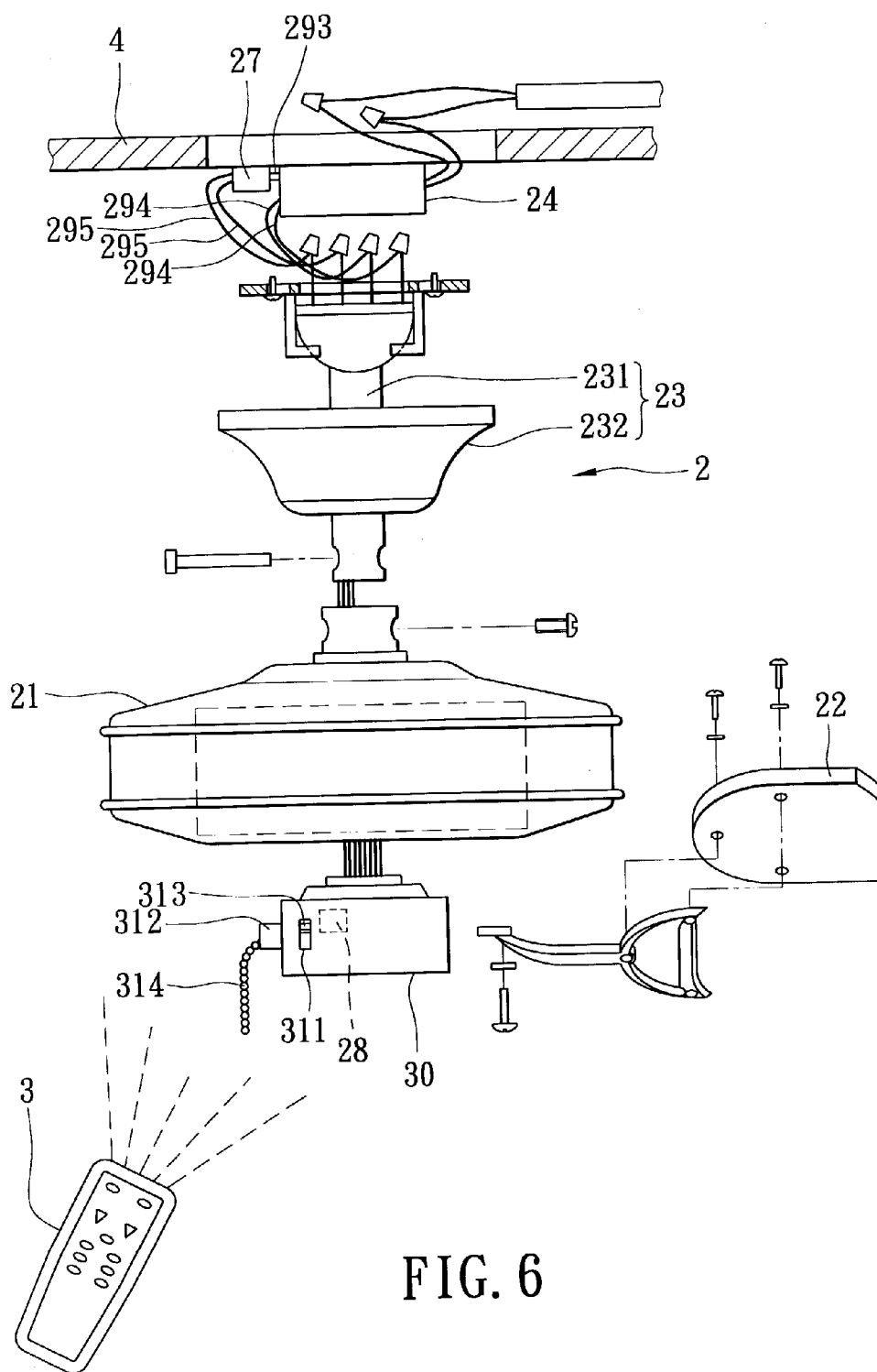
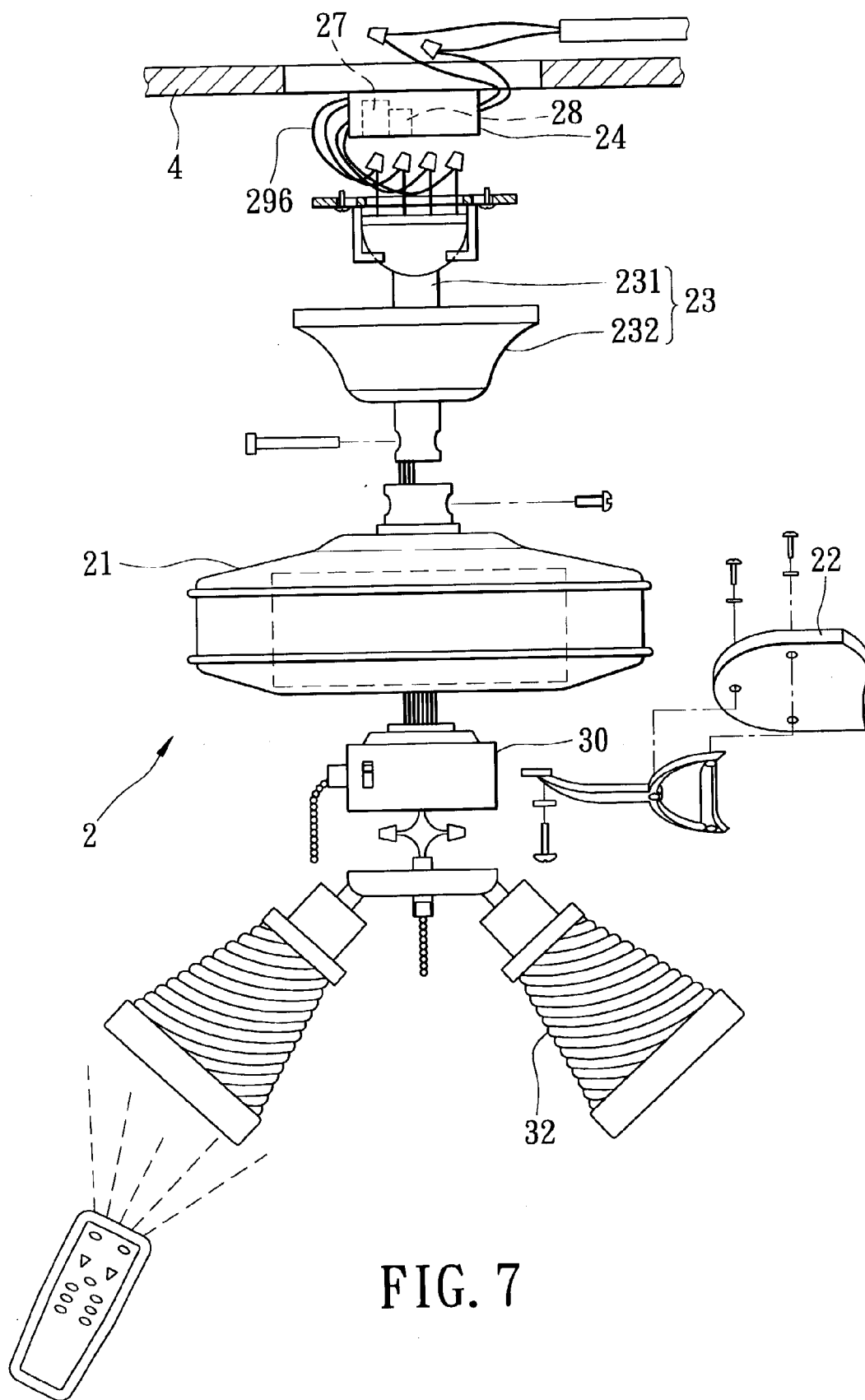

FIG. 6



CEILING FAN WITH BI-DIRECTIONAL ROTATION CONTROL

BACKGROUND OF THE INVENTION

[0001] 1. Field of the Invention

[0002] The invention relates to a ceiling fan, more particularly to a ceiling fan with bi-directional rotation control that can be implemented with relative ease and at a relatively low cost.

[0003] 2. Description of the Related Art

[0004] Referring to **FIGS. 1 and 2**, a conventional ceiling fan **1** disclosed in U.S. Pat. No. 6,211,632 is shown to include a motor **11**, blades **12** connected to the motor **11**, a support assembly **13**, a remote receiver **14**, a switch box **16**, and a direction control unit **17**. The support assembly **13** includes a canopy **132** and a hanger rod **131** suspended from the canopy **132** and extended through the motor **11**. The remote receiver **14** is arranged inside the canopy **132**, and is used in combination with a remote controller **10** to control actuation of the motor **11** through the direction control unit **17**. The switch box **16** is secured to the bottom end of the hanger rod **131**. The direction control unit **17** is arranged inside the switch box **16**, and includes male and female connectors **170, 171** for connecting the direction control unit **17** to the remote receiver **14** and motor coils **111, 112** of the motor **11**, a power circuit **172** for supplying power to the direction control unit **17** via the connectors **170, 171**, a detect circuit **173** for sensing signal received by the remote receiver **14**, a microprocessor **174** connected to and receiving a control signal from the detect circuit **173**, and a relay drive circuit **175** connected to and controlled by the microprocessor **174**. The direction control unit **17** further includes a switch circuit **177** having two relay switches operated synchronously under the control of the relay drive circuit **175**. The switch circuit **177** is connected to the motor coils **111, 112** via the male and female connectors **170, 171**. When the relay drive circuit **175** is activated, the relay switches of the switch circuit **177** change states to change the direction of current in the motor coil **111, 112** to result in a change in the rotation direction of the motor **11**. A manually operated control unit **18** is also arranged in the switch box **16** and is connected electrically to the direction control unit **17** via a coupling capacitor **176** and female and male connectors **179, 178**. Therefore, operation of the ceiling fan **1** can be manually controlled as well via the control unit **18**.

[0005] In the aforesaid ceiling fan **1**, the direction control unit **17** is arranged in the switch box **16** to simplify installation of the direction control unit **17**. However, the arrangement as such requires connectors **170, 171** to connect the direction control unit **17** to the motor coils **111, 112**, the remote receiver **14**, and an external power supply. Moreover, as many as nine connection lines are required to be disposed in the relatively thin hanger rod **131** in order to establish the required connections of the various fan components to the direction control unit **17**. The wiring installation is thus relatively difficult to conduct.

SUMMARY OF THE INVENTION

[0006] Therefore, the object of the present invention is to provide a ceiling fan with bi-directional rotation control that can be implemented with relative ease and at a relatively low cost.

[0007] According to the present invention, a ceiling fan comprises a motor having motor coils, blades connected to the motor, a support assembly including a canopy and a hanger rod that is suspended from the canopy and that extends to the motor, a remote fan controller arranged inside the canopy, and a direction control unit connected to the remote fan controller and the motor coils. The direction control unit includes a relay switch circuit arranged in the canopy. The remote fan controller is adapted to receive a control signal transmitted wirelessly by a remote controlling device, and controls actuation of the relay switch circuit in response to the control signal received thereby so as to change direction of current in the motor coils in order to control direction of rotation of the motor.

[0008] Preferably, the direction control unit further includes an energizing capacitor connected to the relay switch circuit and the motor coils.

[0009] In one embodiment, the energizing capacitor is arranged in the canopy, and four connecting lines are connected to the relay switch circuit and the energizing capacitor and extend into the hanger rod to connect with the motor coils.

[0010] In another embodiment, the hanger rod extends through the motor and has a bottom end provided with a switch box. The energizing capacitor is arranged in the switch box, and four connecting lines are connected to the relay switch circuit and the remote fan controller and extend through the hanger rod and into the switch box to interconnect the relay switch circuit and the energizing capacitor. Four other connecting lines extend from the switch box and into the hanger rod to interconnect the relay switch circuit and the energizing capacitor with the motor coils.

[0011] In yet another embodiment, the hanger rod similarly extends through the motor and has a bottom end provided with a switch box. The relay switch circuit and the energizing capacitor of the direction control unit are integrated into the remote fan controller in the canopy, and four connecting lines are connected to the remote fan controller and extend through the hanger rod and into the switch box. Four other connecting lines extend from the switch box and into hanger rod to interconnect the relay switch circuit and the energizing capacitor with the motor coils.

BRIEF DESCRIPTION OF THE DRAWINGS

[0012] Other features and advantages of the present invention will become apparent in the following detailed description of the preferred embodiments with reference to the accompanying drawings, of which:

[0013] **FIG. 1** is a partly exploded, fragmentary perspective view of a conventional ceiling fan with bi-directional rotation control;

[0014] **FIG. 2** is a schematic circuit diagram of the conventional ceiling fan of **FIG. 1**;

[0015] **FIG. 3** is a partly exploded, schematic view of the first preferred embodiment of a ceiling fan according to the present invention;

[0016] **FIG. 4** is a schematic circuit diagram of the first preferred embodiment;

[0017] **FIG. 5** is a schematic circuit diagram illustrating a power circuit and a SYNC signal generator of a remote fan controller of the first preferred embodiment;

[0018] FIG. 6 is a partly exploded, schematic view of the second preferred embodiment of a ceiling fan according to the present invention; and

[0019] FIG. 7 is a partly exploded, schematic view of the third preferred embodiment of a ceiling fan according to the present invention.

DETAILED DESCRIPTION OF THE PREFERRED EMBODIMENTS

[0020] Before the present invention is described in greater detail, it should be noted that like elements are denoted by the same reference numerals throughout the disclosure.

[0021] Referring to FIGS. 3, 4 and 5, the first preferred embodiment of a ceiling fan 2 according to the present invention is shown to include a motor 21, blades 22 (only one is shown) connected to the motor 21 in a conventional manner, a support assembly 23, a remote fan controller 24, and a direction control unit. The support assembly 23 is conventional in construction, and includes a canopy 232, and a hanger rod 231 suspended from the canopy 232 and extending to the motor 21. The canopy 232 is adapted to be fixed to a ceiling 4. The remote fan controller 24 is arranged inside the canopy 232, and includes a power circuit 241, a SYNC signal generator 242 connected to the power circuit 241, a microprocessor 243 connected to the SYNC signal generator 242, a speed control circuit 244 connected to the microprocessor 243 and capable of controlling rotation speed of the motor 21, a memory 245 connected to the microprocessor 243 for data storage and retrieval, and a remote receiver 246 connected to the microprocessor 243 and operable so as to detect infrared control signals that are transmitted wirelessly by a handheld remote controlling device 3. The direction control unit is connected electrically to the remote fan controller 24 and motor coils 211, 212 of the motor 21, and includes a relay switch circuit 27 and an energizing capacitor 28. A control line 247 of the microprocessor 243 controls actuation of the relay switch circuit 27. In this embodiment, both the relay switch circuit 27 and the energizing capacitor 28 are disposed in the canopy 232. Moreover, four connecting lines 291 connect the remote fan controller 24 to the relay switch circuit 27 and the energizing capacitor 28. Four other connecting lines 292 are connected to the relay switch circuit 27 and the energizing capacitor 28 and extend into the hanger rod 231 to connect with the motor coils 211, 212.

[0022] During operation, in response to the infrared control signal transmitted by the remote controlling device 3 and received by the remote receiver 246 of the remote fan controller 24, the microprocessor 243 can control actuation of the relay switch circuit 27 to change direction of current in the motor coils 211, 212 from a normal closed state, where the motor 21 is permitted to rotate in a positive direction, to a normal open state, where the motor 21 is permitted to rotate in a negative direction. Preferably, under the control of the microprocessor 243, which refers to the SYNC signal from the SYNC signal generator 242, rotation of the motor 21 is first stopped before the direction of rotation of the motor 21 is reversed from the positive direction to the negative direction and vice versa.

[0023] FIG. 6 illustrates the second preferred embodiment of a ceiling fan 2 according to the present invention. Unlike

the previous embodiment, the hanger rod 231 extends through the motor 21 and has a switch box 30 mounted on a bottom end thereof.

[0024] A conventional manually operated control unit is arranged in the switch box 30 and includes a direction control switch 311 and a speed control switch 312. The direction control switch 311 is provided with a slide button 313, which is operable so as to select rotation of the motor 21 in the positive or negative direction. The speed control switch 312 is associated with a pull chain 314 to control rotation speed of the motor 21.

[0025] When compared with the previous embodiment, the direction control unit also includes the relay switch circuit 27 and the energizing capacitor 28. However, while the relay switch circuit 27 remains arranged in the canopy 232, the energizing capacitor 28 in this embodiment is arranged in the switch box 30. With additional reference to FIG. 4, two first connecting lines 293 connect the remote fan controller 24 to the relay switch circuit 27. Two second connecting lines 294 from the remote fan controller 24 and two third connecting lines 295 from the relay switch circuit 27 extend through the hanger rod 231 and into the switch box 30 to connect with the terminals of the energizing capacitor 28. Four other connecting lines extend from the switch box 30 and into the hanger rod 231 to connect with the motor coils 211, 212, thereby establishing electrical connection between the motor coils 211, 212 and the relay switch circuit 27 and the energizing capacitor 28 of the direction control unit.

[0026] In the second preferred embodiment, control of the direction of rotation and the rotation speed is possible with the use of the control switches 311, 312 or the remote controlling device 3.

[0027] FIG. 7 illustrates the third preferred embodiment of a ceiling fan 3 according to the present invention. Like the embodiment of FIG. 6, the hanger rod 231 extends through the motor 21 and has a switch box 30 mounted on a bottom end thereof. The switch box 30 further has a lamp unit 32 mounted thereon.

[0028] Like the previous embodiments, the direction control unit also includes the relay switch circuit 27 and the energizing capacitor 28. However, the relay switch circuit 27 and the energizing capacitor 28 of the direction control unit are integrated into the remote fan controller 24, which is arranged in the canopy 232. Accordingly, in this embodiment, four connecting lines 296 from the remote fan controller 24 extend through the hanger rod 231 and into the switch box 30. Four other connecting lines extend from the switch box 30 and into the hanger rod 231 to connect with the motor coils 211, 212, thereby establishing electrical connection between the motor coils 211, 212 and the relay switch circuit 27 and the energizing capacitor 28 of the direction control unit. Because the connecting lines 296 extend into the switch box 30, power can be supplied to the lamp unit 32 through the connecting lines 296.

[0029] Due to the fewer number of connecting lines that are required to extend through the hanger rod 231 to permit remote controlled operation of the ceiling fan 2, it is apparent that the ceiling fan 2 with bi-directional rotation control according to this invention can indeed be implemented with relative ease and at a relatively low cost. The object of the invention is thus met.

[0030] While the present invention has been described in connection with what is considered the most practical and preferred embodiments, it is understood that this invention is not limited to the disclosed embodiments but is intended to cover various arrangements included within the spirit and scope of the broadest interpretation so as to encompass all such modifications and equivalent arrangements.

I claim:

1. A ceiling fan comprising a motor having motor coils, blades connected to said motor, a support assembly including a canopy and a hanger rod that is suspended from said canopy and that extends to said motor, a remote fan controller arranged inside said canopy, and a direction control unit connected to said remote fan controller and said motor coils, said direction control unit including a relay switch circuit arranged in said canopy,

wherein said remote fan controller is adapted to receive a control signal transmitted wirelessly by a remote controlling device, and controls actuation of said relay switch circuit in response to the control signal received thereby so as to change direction of current in said motor coils in order to control direction of rotation of said motor.

2. The ceiling fan as claimed in claim 1, wherein said direction control unit further includes an energizing capacitor connected to said relay switch circuit and said motor coils.

3. The ceiling fan as claimed in claim 2, wherein said energizing capacitor is arranged in said canopy.

4. The ceiling fan as claimed in claim 3, further comprising four connecting lines that are connected to said relay switch circuit and said energizing capacitor and that extend into said hanger rod to connect with said motor coils.

5. The ceiling fan as claimed in claim 2, wherein said hanger rod extends through said motor and has a bottom end provided with a switch box.

6. The ceiling fan as claimed in claim 5, wherein said energizing capacitor is arranged in said switch box, said ceiling fan further comprising four connecting lines that are connected to said relay switch circuit and said remote fan controller and that extend through said hanger rod and into said switch box to interconnect said relay switch circuit and said energizing capacitor, and four other connecting lines that extend from said switch box and into said hanger rod to interconnect said relay switch circuit and said energizing capacitor with said motor coils.

7. The ceiling fan as claimed in claim 5, wherein said relay switch circuit and said energizing capacitor of said direction control unit are integrated into said remote fan controller in said canopy, said ceiling fan further comprising four connecting lines that are connected to said remote fan controller and that extend through said hanger rod and into said switch box, and four other connecting lines that extend from said switch box and into hanger rod to interconnect said relay switch circuit and said energizing capacitor with said motor coils.

* * * * *