



US 20060157364A1

(19) **United States**

(12) **Patent Application Publication**  
**Sproul et al.**

(10) **Pub. No.: US 2006/0157364 A1**

(43) **Pub. Date: Jul. 20, 2006**

(54) **TOOL STORAGE SYSTEM**

**Publication Classification**

(76) Inventors: **Paul J. Sproul**, Burlington, WI (US);  
**David J. Krause**, Lake Geneva, WI (US)

(51) **Int. Cl.**  
**B65D 85/28** (2006.01)

(52) **U.S. Cl.** ..... **206/372**

(57) **ABSTRACT**

A tool storage system includes a body, such as a panel, to which tools may be attached, a base to which the body is removably fastened, and a fastening mechanism for connecting the body to the base so that the body may be attached to the base or removed and used remote therefrom. In one form, the fastening mechanism includes a hinge connected to the body and the base for providing an axis about which the body may be rotated with respect to the base, and a latch connected to the base and movable between a first position, or secured position, wherein the latch secures the body to the base and a second position, or released position, wherein the latch releases the body so that it may be removed from the base. In another form, the body is secured to the base via a plurality of latches. In yet another form, the body is secured to the base via quarter turn fasteners.

Correspondence Address:  
**FITCH EVEN TABIN AND FLANNERY**  
**120 SOUTH LA SALLE STREET**  
**SUITE 1600**  
**CHICAGO, IL 60603-3406 (US)**

(21) Appl. No.: **11/330,812**

(22) Filed: **Jan. 12, 2006**

**Related U.S. Application Data**

(60) Provisional application No. 60/643,848, filed on Jan. 14, 2005.

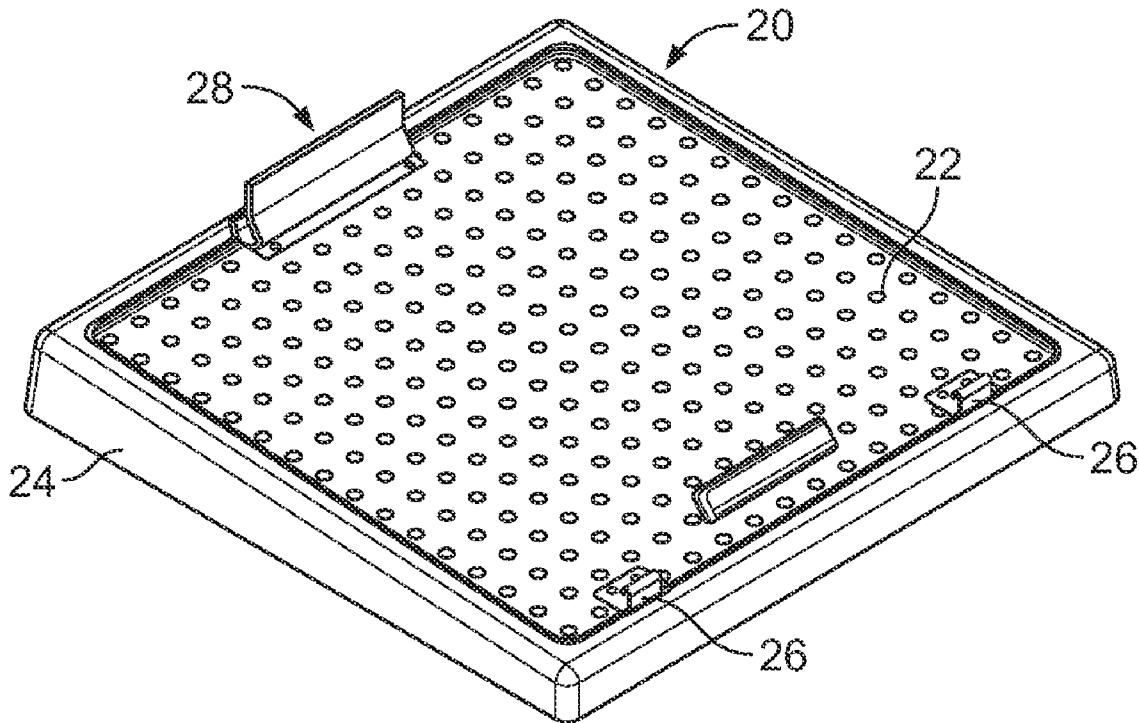

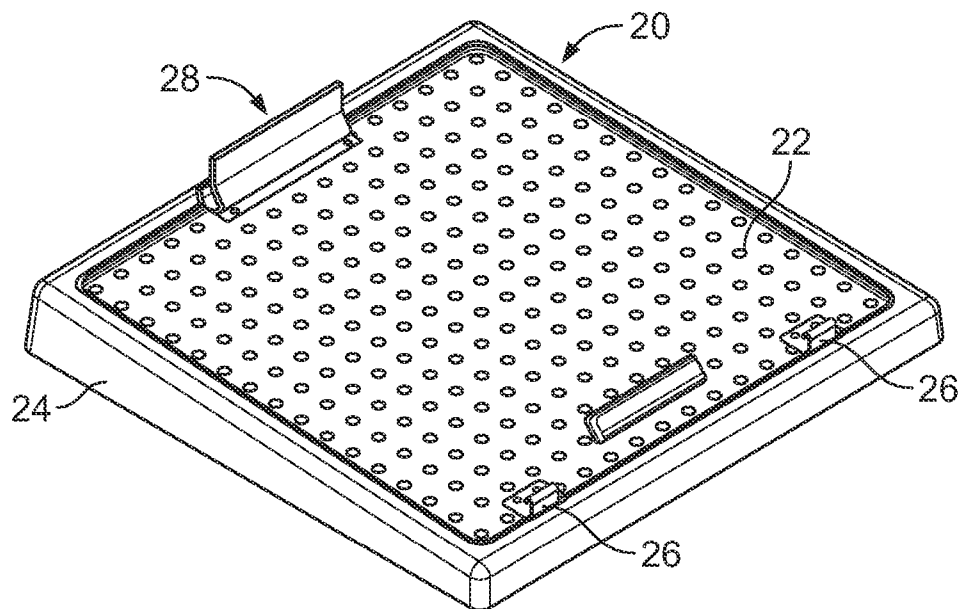

FIG. 1A

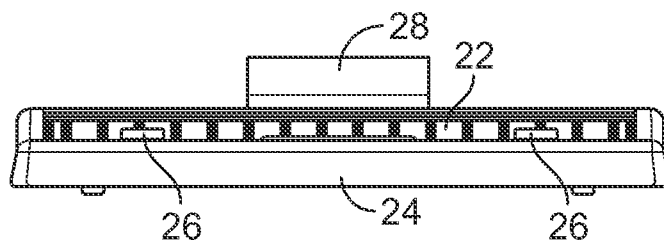

FIG. 1B



FIG. 1C

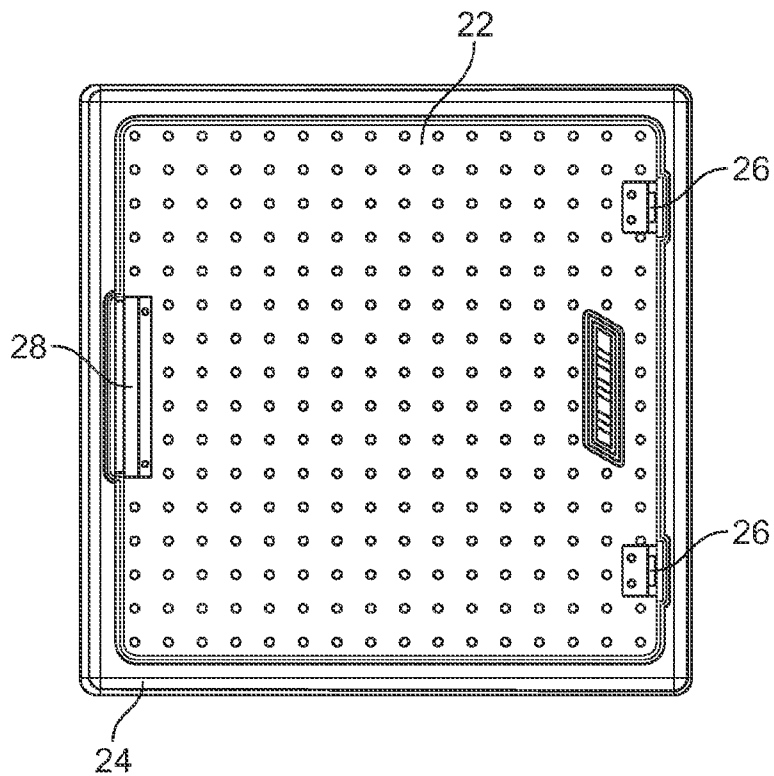

FIG. 1D

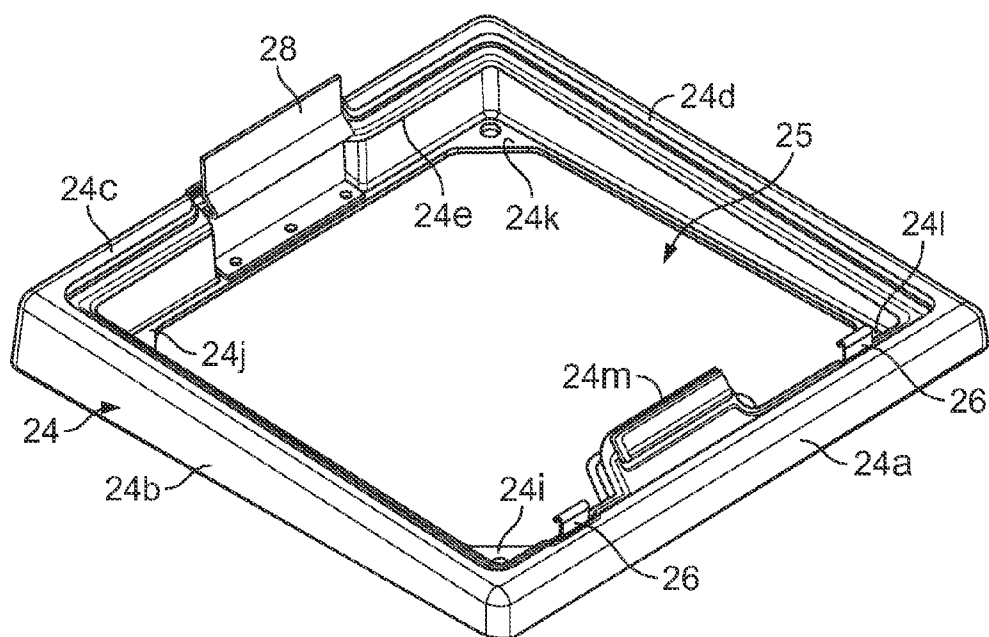

FIG. 2A

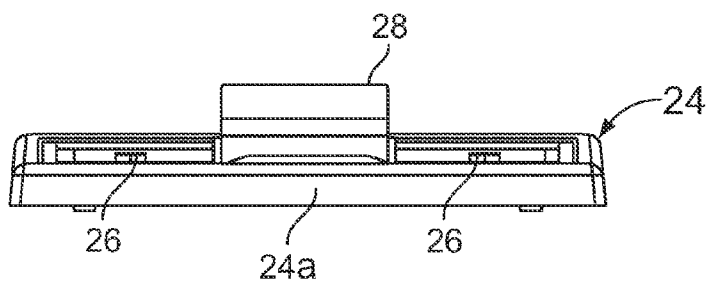

FIG. 2B

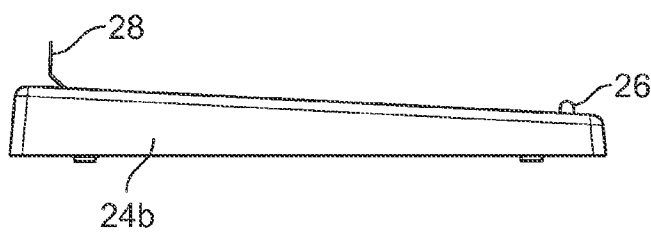

FIG. 2C

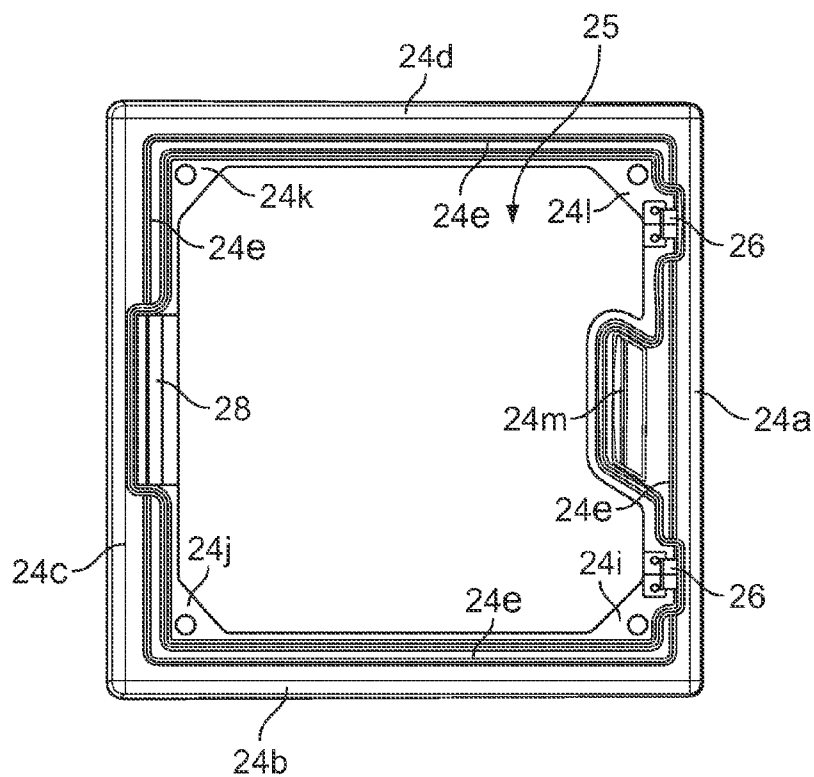

FIG. 2D

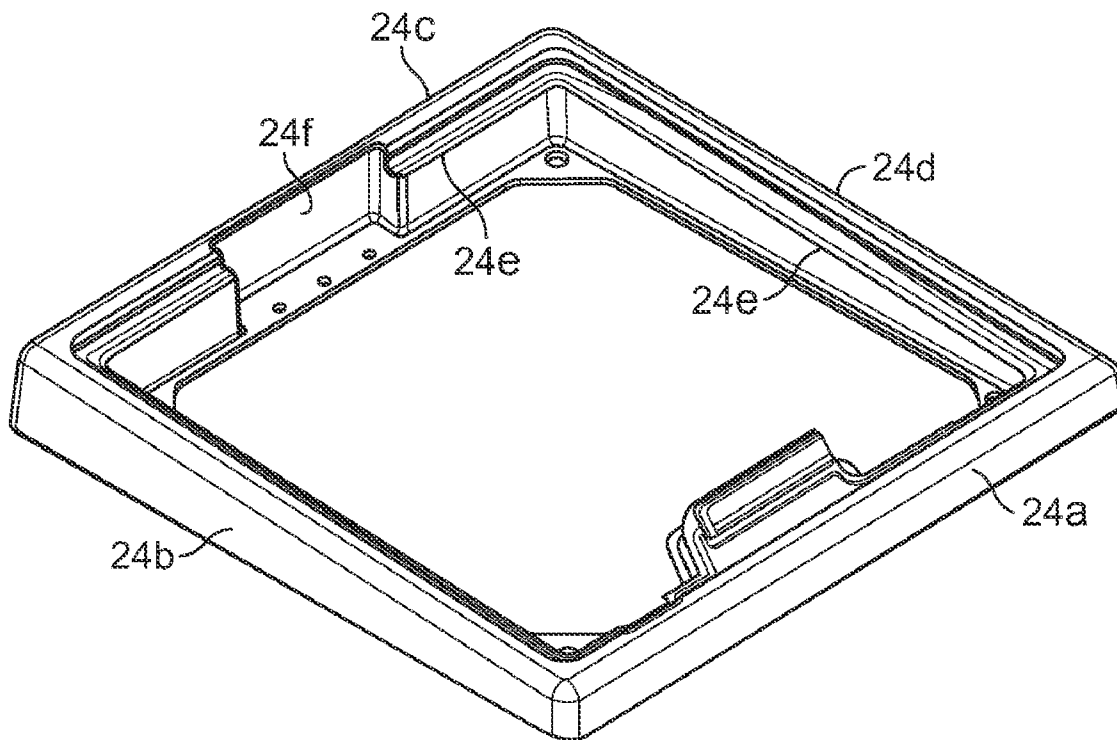

FIG. 2E

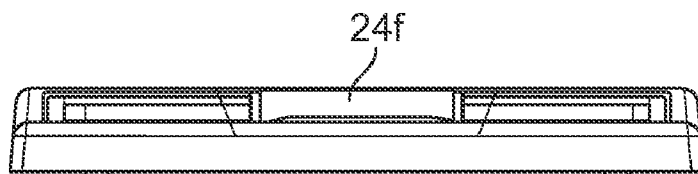

FIG. 2F



FIG. 2G

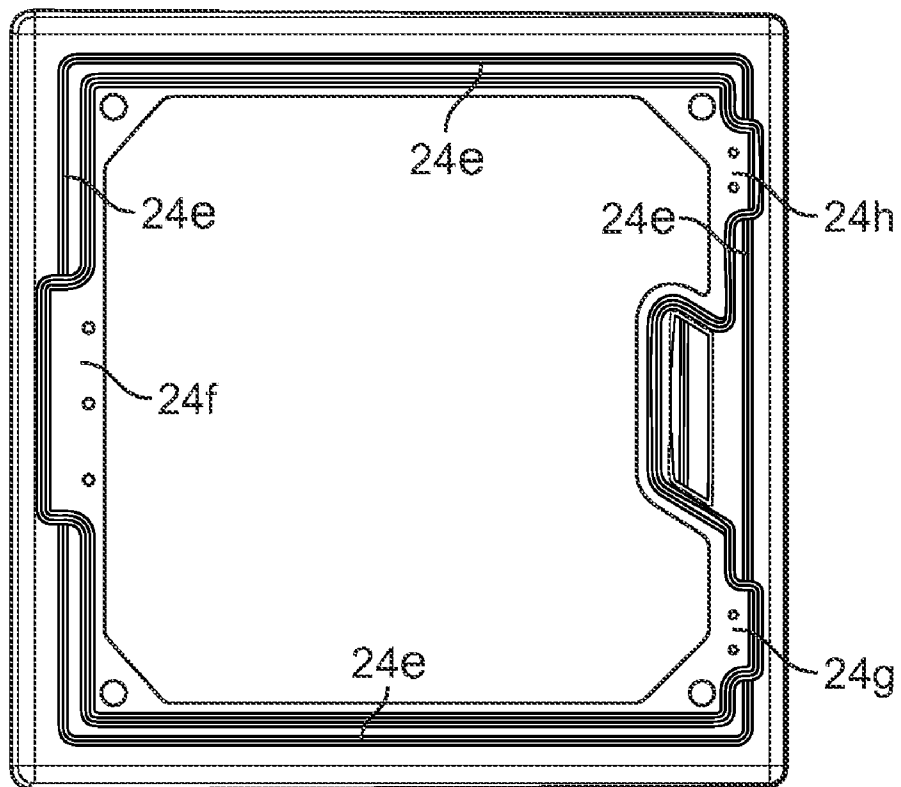

FIG. 2H

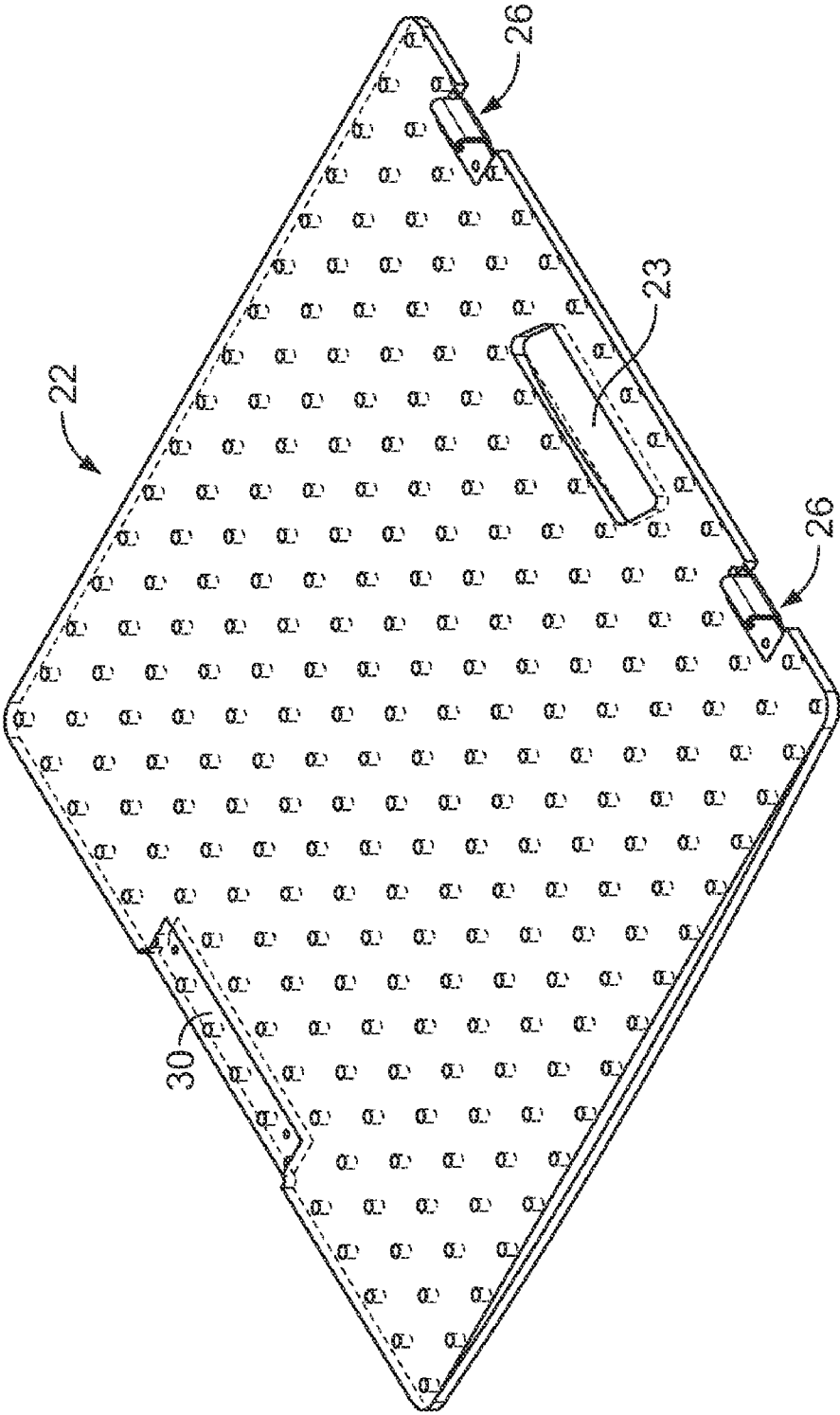

FIG. 3A

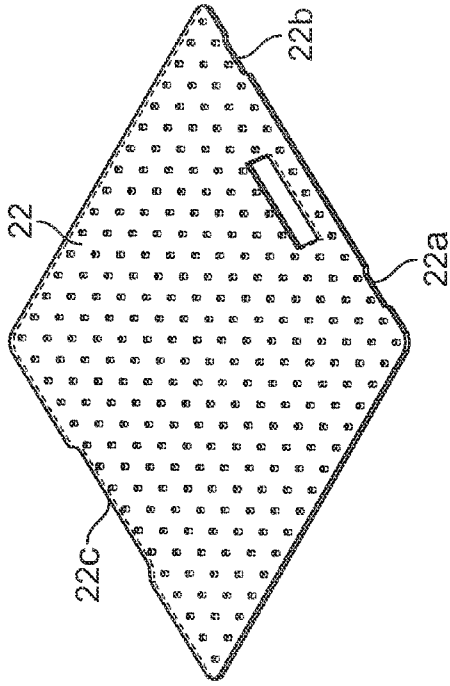

FIG. 3B



FIG. 3C

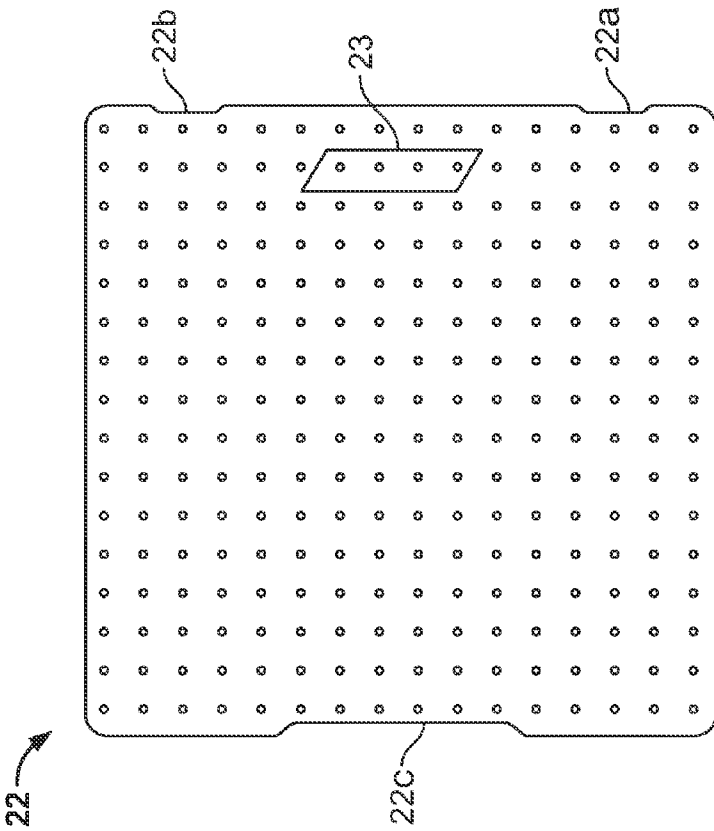

FIG. 3E



FIG. 3D

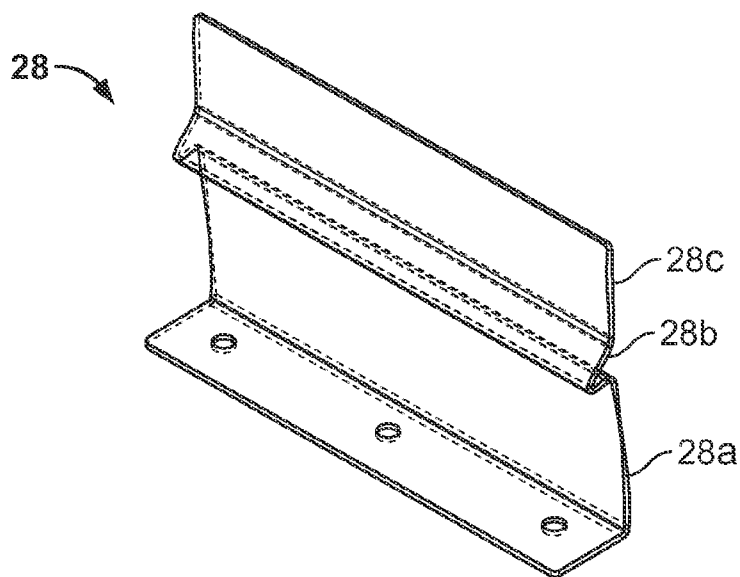

FIG. 4A

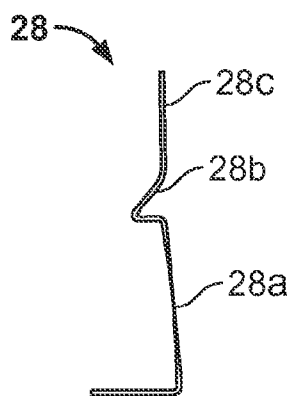

FIG. 4B

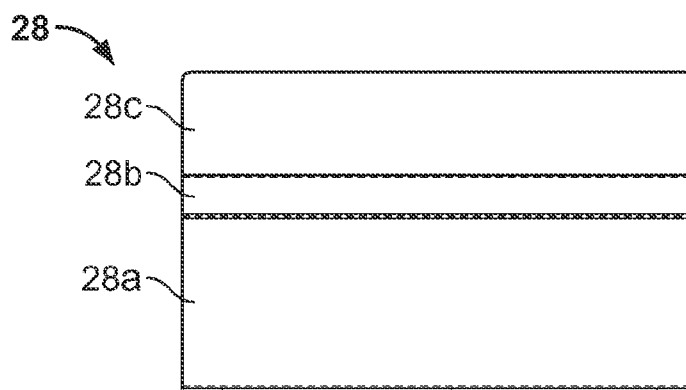

FIG. 4C

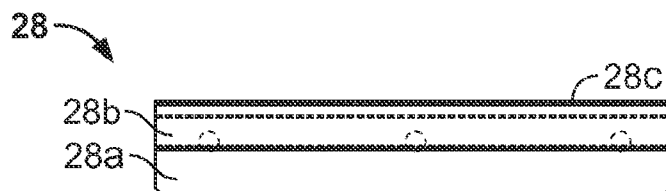

FIG. 4D

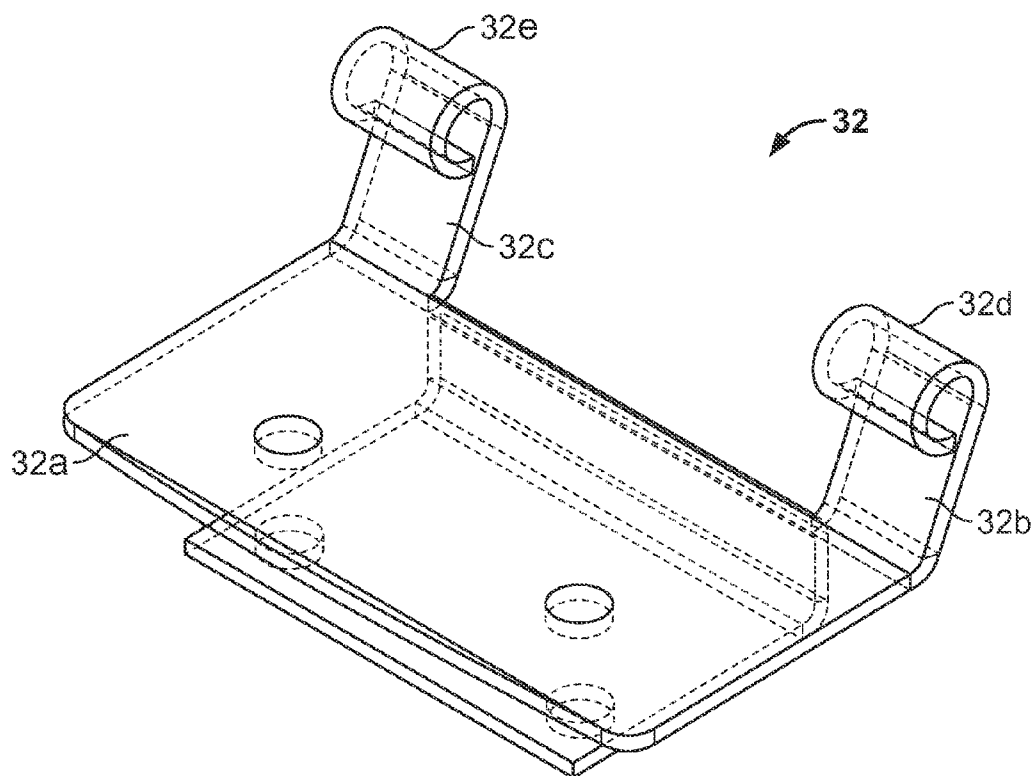

FIG. 5A

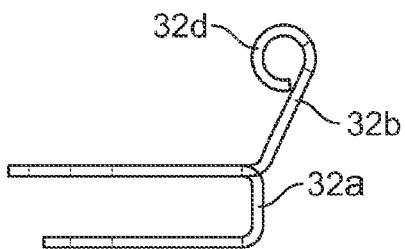

FIG. 5B

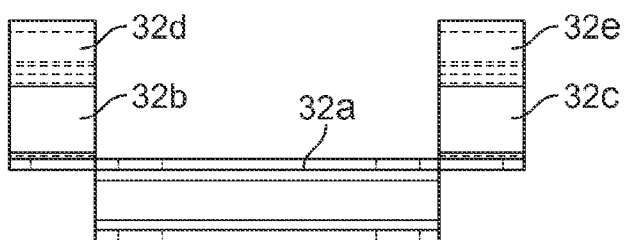

FIG. 5C

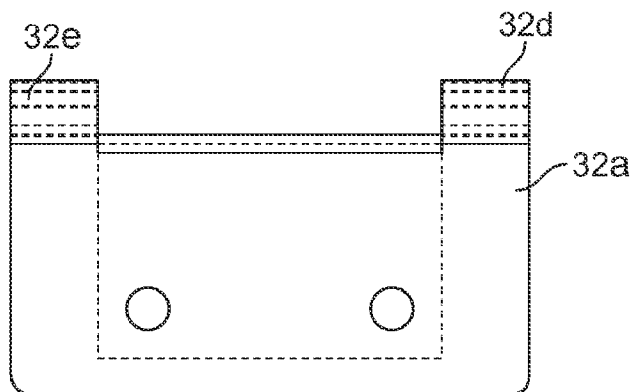

FIG. 5D

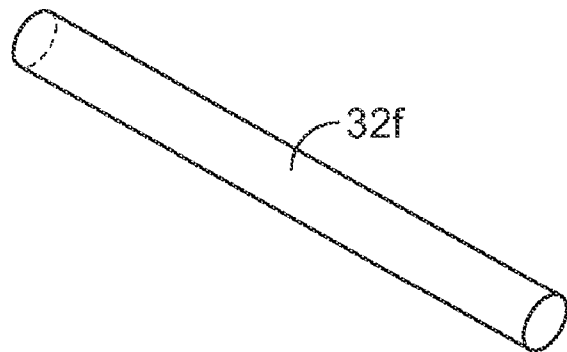

FIG. 6A

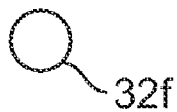

FIG. 6B



FIG. 6C

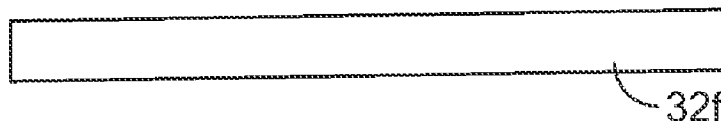

FIG. 6D

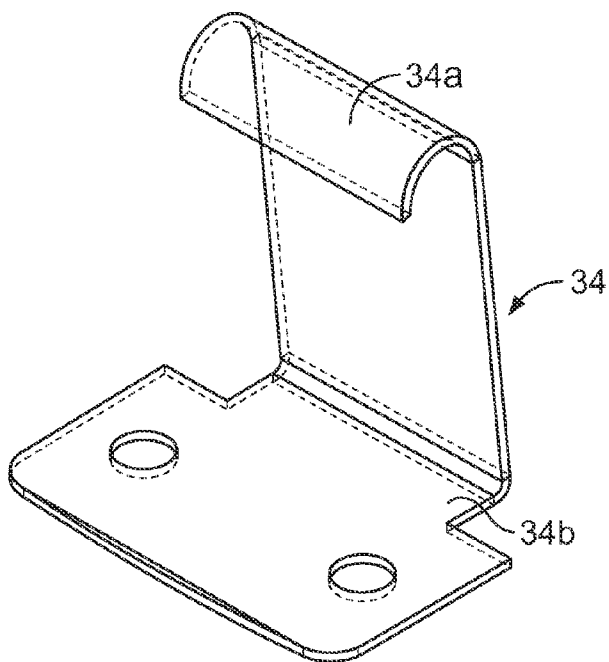

FIG. 7A

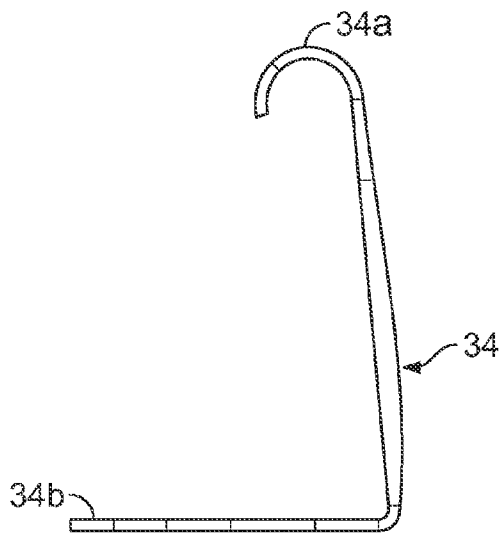

FIG. 7B

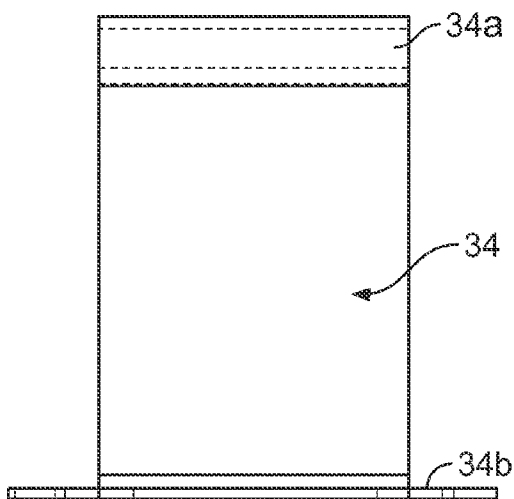

FIG. 7C

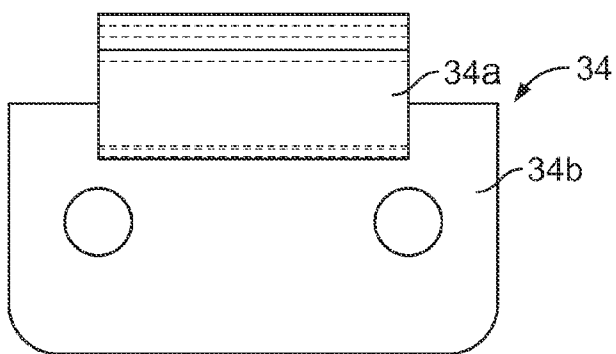

FIG. 7D

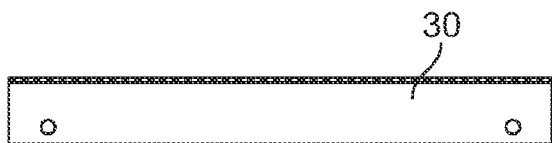

FIG. 8D

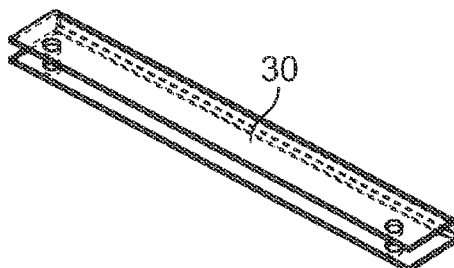

FIG. 8A

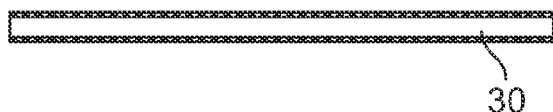

FIG. 8C



FIG. 8B

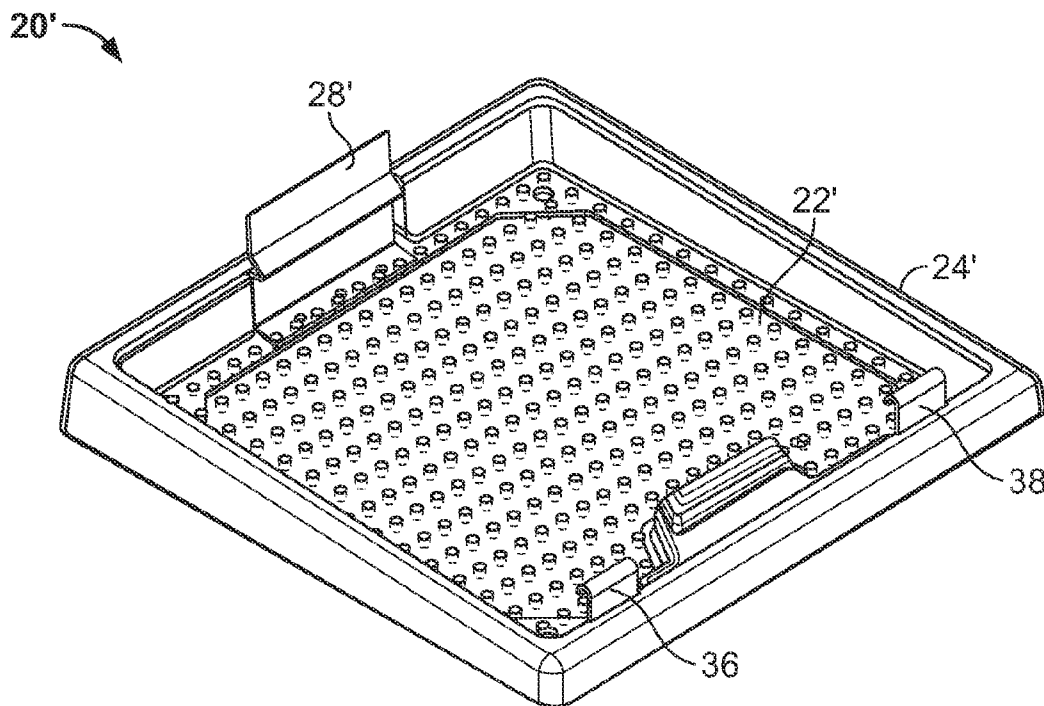

FIG. 9A

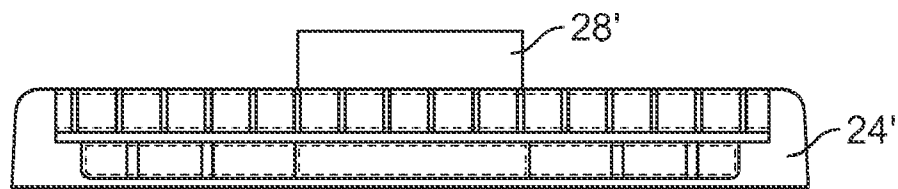

FIG. 9B

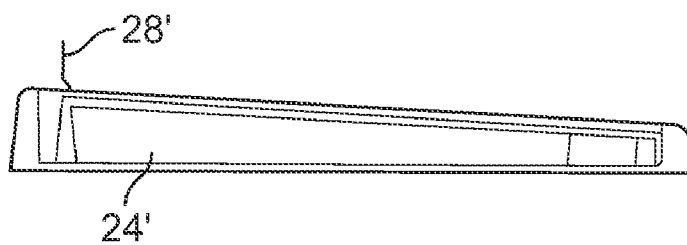

FIG. 9C

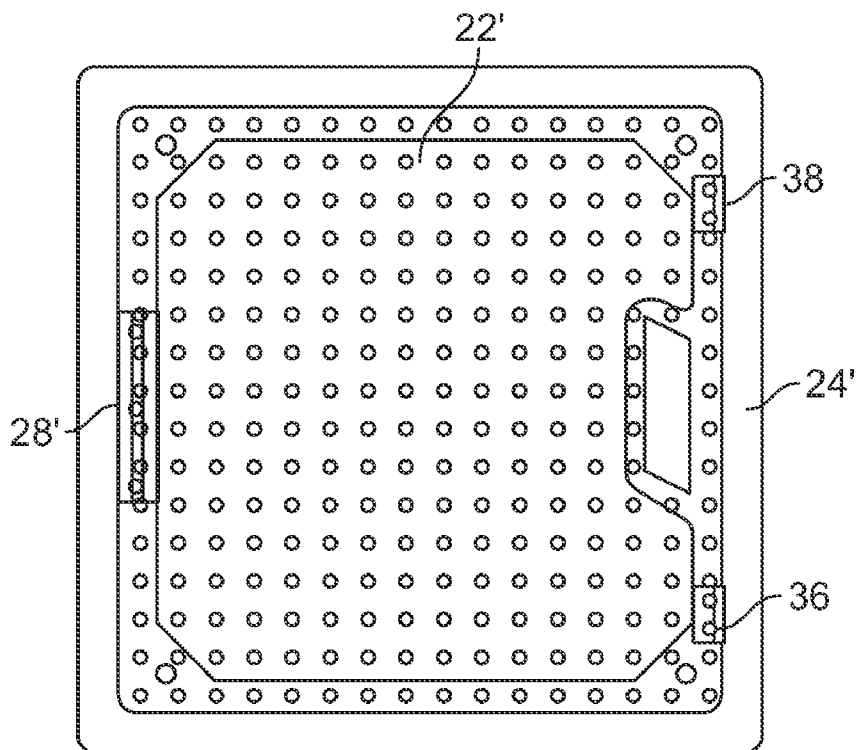

FIG. 9D

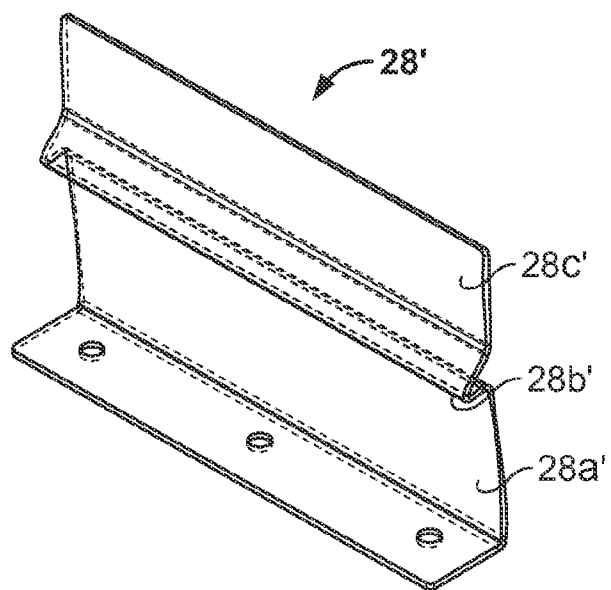

FIG. 10A

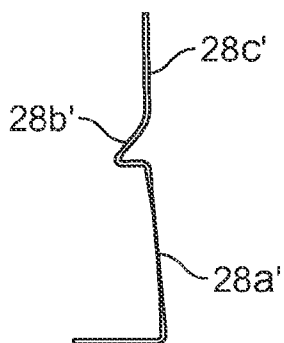

FIG. 10B

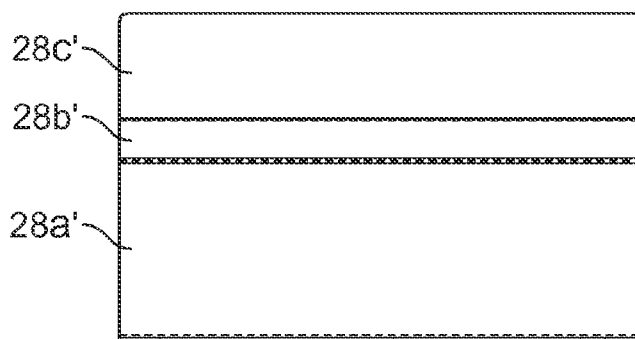

FIG. 10C

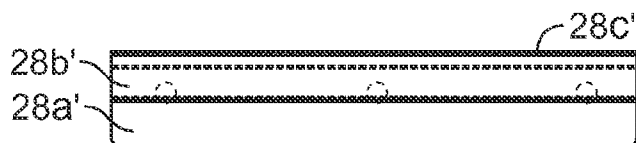

FIG. 10D

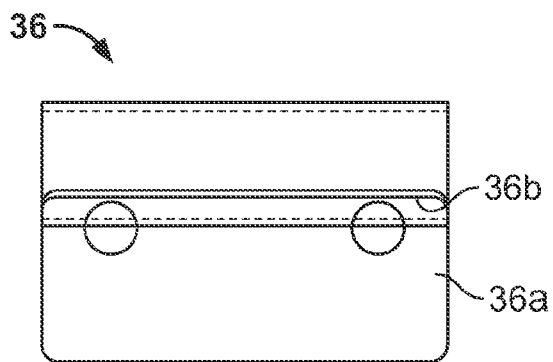

FIG. 11D

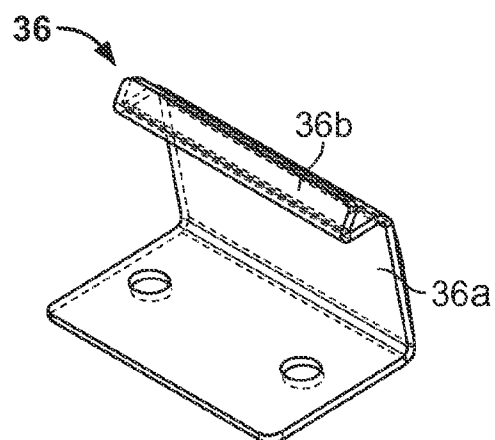

FIG. 11A

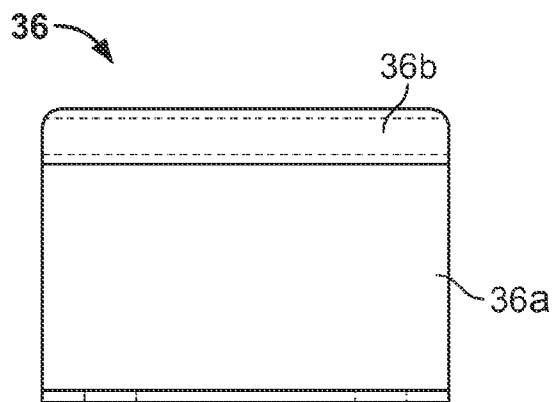

FIG. 11C

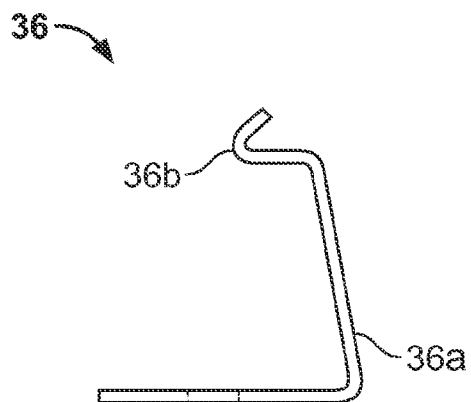

FIG. 11B

**TOOL STORAGE SYSTEM**

**CROSS-REFERENCE TO RELATED APPLICATION**

[0001] This application claims benefit of U.S. Provisional Application No. 60/643,848, filed Jan. 14, 2005, which is hereby incorporated herein by reference in its entirety.

**BACKGROUND OF THE INVENTION**

[0002] 1. Field of the Invention

[0003] The present invention relates to an improved tool storage system, and more particularly, an improved fastening mechanism for a tool display panel.

[0004] 2. Description of the Related Art

[0005] Tools are stored in a variety of different manners. For example, some tools are stored on panels which not only retain the tool but also display the tool so that a user or potential purchaser can easily find what he or she is looking for. In addition, these storage systems may be used in a variety of different applications. Conventional tool trucks or mobile tool stores, for example, often use panels, such as peg board, to store tools so that the tools may easily be displayed in the vehicle or located and removed from the vehicle when the tool salesman wishes to bring a particular tool or tools into a potential customer's workplace, such as a shop.

[0006] A shortcoming with conventional tool storage systems, however, is that the salesman typically cannot easily transport the tools from the tool truck to the potential customer's workplace. For example, the salesman may have to spend needless time and energy individually removing each tool from the peg board before entering the customer's workplace. This problem is further compounded when removing tools from hard to reach surfaces, such as the ceiling of the tool truck, where the tools are traditionally secured to the ceiling via shock cord or the like.

[0007] Once removed, the salesman will likely have to place the tools in a bag or other carrier in order to transport the tools from the tool truck to the customer's workplace. These carriers typically do not make the tools easy to display to the potential customer, thereby hindering the salesman's ability to show and sell tools. For example, salesmen that have to dig through bags to pull out and display tools to potential customers often lose the potential customer's interest.

[0008] Accordingly, it has been determined that the need exists for an improved tool storage system and fastening mechanism therefor that overcome the aforementioned limitations.

**SUMMARY OF THE INVENTION**

[0009] A tool storage system includes a body, such as a panel, to which tools may be attached, a base to which the body is removably fastened, and a fastening mechanism for connecting the body to the base so that the body may be attached to the base or removed and used remote therefrom. In one form, the fastening mechanism includes a hinge connected to the body and the base for providing an axis about which the body may be rotated with respect to the base, and a latch connected to the base and movable between

a first position, or secured position, wherein the latch secures the body to the base and a second position, or released position, wherein the latch releases the body so that it may be removed from the base. In another form, the body is secured to the base via a plurality of latches. In yet another form, the body is secured to the base via other fasteners, such as quarter turn fasteners.

**BRIEF DESCRIPTION OF THE DRAWINGS**

[0010] FIGS. 1A-D are perspective, end, side and top views, respectively, of a tool storage system in accordance with the invention;

[0011] FIGS. 2A-D are perspective, end, side and top views, respectively, of the base of the tool storage system of FIGS. 1A-D, showing a portion of the fastening mechanism illustrated therein;

[0012] FIGS. 2E-H are perspective, end, side and top views, respectively, of the base of the tool storage system of FIGS. 1A-D, without the portions of the fastening mechanism;

[0013] FIG. 3A is a perspective view of the body of the tool storage system of FIGS. 1A-D, showing a portion of the fastening mechanism illustrated therein;

[0014] FIGS. 3B-E are perspective, end, side and top views, respectively, of the body of the tool storage system of FIGS. 1A-D, without the portions of the fastening mechanisms;

[0015] FIGS. 4A-D are perspective, end, side and top views, respectively, of the latch of the tool storage system of FIGS. 1A-D;

[0016] FIGS. 5A-D are perspective, end, side and top views, respectively, of the hinge mount bracket of the tool storage system of FIGS. 1A-D;

[0017] FIGS. 6A-D are perspective, end, side and top views, respectively, of the bar for the hinge mount bracket of the tool storage system of FIGS. 1A-D;

[0018] FIGS. 7A-D are perspective, end, side and top views, respectively, of the hinge receptacle of the tool storage system of FIGS. 1A-D;

[0019] FIGS. 8A-D are perspective, end, side and top views, respectively, of the guard of the tool storage system of FIGS. 1A-D;

[0020] FIGS. 9A-D are perspective, end, side and top views, respectively, of an alternate tool storage system in accordance with the invention;

[0021] FIGS. 10A-D are perspective, end, side and top views, respectively, of the first latch of the tool storage system of FIGS. 9A-D; and

[0022] FIGS. 11A-D are perspective, end, side and top views, respectively, of the second latch of the tool storage system of FIGS. 9A-D.

**DESCRIPTION OF THE PREFERRED EMBODIMENTS**

[0023] Turning now to the drawings and, in particular FIGS. 1A-D, wherein a tool storage system in accordance with the invention is shown generally at reference numeral

20, the tool storage system 20 includes a body, such as panel 22, to which tools may be attached, a base 24 to which the body 22 is removably fastened, and a fastening mechanism for connecting the body to the base so that the body may be attached to the base or removed and used remote therefrom. In the embodiment illustrated, the fastening mechanism includes a hinge 26 connected to the body 22 and the base 24 for providing an axis about which the body 22 may be rotated with respect to the base 24, and a latch 28 connected to the base 22 and movable between a first position, or secured position, wherein the latch 28 secures the body 22 to the base 24 and a second position, or released position, wherein the latch 28 releases the body 22 so that it may be removed from the base 24.

[0024] The base 24 preferably forms a receptacle for receiving the body 22. In the form illustrated in FIGS. 2A-F, for example, the base 24 forms a generally rectangular wall structure having a first wall 24a, a second wall 24b, a third wall 24c and a fourth wall 24d, which collectively define a rectangular recess or opening 25 into which the body 22 may be disposed. In this embodiment, the walls 24a-d define an interior shoulder or step 24e that reduces the diameter of the rectangular opening 25 and provides a generally flat surface or ledge against which the body 22 may be positioned. As will be discussed in greater detail below, the body 22 may then be sandwiched between the shoulder 24e and the fastening mechanism to secure the body 22 into the base 24.

[0025] The base 24 may also include a mounting bracket for mounting the base 24 to a structure, such as a wall or ceiling. For example, in the form illustrated in FIGS. 1A-2H, the corners of adjoining wall members 24a-d are connected to form triangular mounts 24i, 24j, 24k and 24l. The mounts 24i-l are generally flat surfaces that define through holes or bores into which fasteners may be disposed.

[0026] The base 24 may also include designated areas designed for mounting the latch 28 and/or hinge 26 therefrom. For example, in the form illustrated in FIGS. 2A-H, the base 24 defines a recess or depression 24f for receiving the latch 28 and recesses or depressions 24g and 24h for receiving hinges 26. In a preferred form, the recesses 24f-h allow portions of the latch 28 and hinge 26 to remain out of the way of the body 22 so that they do not obstruct the body 22 or its ability to be secured to the base. The center lines of recesses 24f-h are preferably aligned with and colinear to the center lines of the latch 28 and hinges 26, respectively. The recesses 24f-h also form generally flat surfaces to which the latch 28 and hinges 26 may be mounted. As illustrated in FIG. 2H, the flat surface of recesses 24f-h may define through openings or bores which correspond to openings or bores defined by the latch 28 and hinges 26 so that the these items may be fastened to the base 24 via any traditional fastening means, such as screws, bolts or rivets. The latch recess 24f and hinge recesses 24g-h are preferably located on opposite sides of the base 24 so that the body 22 pivots or swings away from the latch 28 when the latch is moved into the second position in order to avoid inadvertently latching the body 22.

[0027] Although the embodiment illustrated shows one latch 28 and two hinges 26, it should be understood that in alternate embodiments, the latch 28 may be replaced with a plurality of latches or that the hinge 26 may be replaced with a single hinge 26. In addition, the location of the latches and

hinges can be varied. For example, the two hinges 26 illustrated in FIGS. 1A-D may be replaced with a single hinge with the single hinge either being centered on a side of the body 22 or running almost the entire length of the body 22. In another form, the apparatus may have two latches located either on a wall opposite the wall with the hinge or on the walls adjoining the wall with the hinge. In the latter configuration, however, the latches will preferably be located at the end of the adjoining wall farthest from the wall with the hinge 26 in order to make it easier to remove the body 22 from the base 24. In yet other embodiments, the latches and hinges may be connected via other fasteners, such as adhesives, if desired.

[0028] The base 24 may also define a surface for presenting indicia such as trademarks. In the form illustrated in FIGS. 1A-2H, the base defines an indicia surface 24m that extends from the inner wall surface of front wall 24a. The indicia surface 24m extends up from a surface generally coplanar with the shoulder 24e of wall 24a and forms a projection, such as an island, that extends through an opening defined by body 22. This configuration allows the indicia to be visible regardless of whether or not the body 22 is secured to the base 24 and will be discussed in further detail below with respect to body 22. The body 24 may also be angled in order to make the indicia more visible. The shoulder 24e is also preferably angled in order to angle the body 22 disposed therein so that it easier to identify the tools that are connected to the body 22 when it is secured to the base 24.

[0029] Although the base 24 illustrated in FIGS. 1A-2H is shown with an interior shoulder 24e, it should be understood that alternate embodiments may be provided without a shoulder. For example, in one form, the interior wall members of walls 24a-d may simply be sloped, angled or tapered in order to reduce the diameter of opening 25 to capture body 22. In another form, the body 22 may simply rest against the top of the base 24, rather than being recessed or disposed within the base 24.

[0030] The body 22 preferably corresponds in shape to that of the base 24 and, more particularly, to that of the opening 25 defined by the base 24. In the embodiment illustrated in FIGS. 3A-E, the body 22 is a fiber-board having a plurality of perforations for receiving hooks and/or other fasteners, such as shock cord, to secure tools to the body 24. The fiber board or peg-board 22 preferably defines an opening 23 to form a handle for carrying the body 22 when it is removed from the base 24. The opening 23 also provides an aperture through which the indicia surface 24m discussed above may be viewed or even disposed.

[0031] The body 22 may also include designated areas designed for mounting the hinge 26 therefrom. For example, in the form illustrated in FIGS. 3A-E, the body 22 defines recesses 22a and 22b for receiving hinges 26. The recesses 22a-b allow the hinges to be placed further in on the body 22 so that they remain out of the way of the base 24 and/or do not interfere with the body's ability to be secured to the base 24. The center lines of the hinges 26 are preferably aligned with and colinear to the center lines of the recesses 22a-b and the hinges 26 are preferably fastened to the body 22 with a fastener, such as a screw, bolt, rivet or adhesive.

[0032] In order to protect the body 22 from wear caused by repeated latching and unlatching of latch 28, the body 22

may also include a guard for covering at least a portion of the body 22 that comes into contact with the latch 28. In the form illustrated in FIGS. 1A-D and 8A-D, the body 22 includes a recess or depression 22c for receiving a generally U-shaped guard 30, which is a metal sheet wrapped around the top, side and bottom of the body 22 adjacent the recess 22c. The guard 30 may be attached to the body 22 via a conventional fastener and preferably will be as wide as the latch 28 to ensure that no portion of the latch 28 comes into direct contact with the fiber-board body 22. In alternate embodiments, the guard 30 may simply be a flat plate or a plurality of flat plates that cover a portion of the body 22 which comes into contact with the latch 28.

[0033] A preferred form of latch 28 is illustrated in FIGS. 4A-D. This latch 28 is made of a metal, such as steel, and has a first portion 28a defining a mount for connecting the latch 28 to the base 24, a second portion 28b defining a mating structure for mating with the body 22 to secure the body to the base 24, and a third portion 28c defining a handle, grip or operable end for actuating the latch 28. The first portion 28a is generally L-shaped, but preferably has a bend less than ninety degrees in order to bias the latch 28 in its latched position (e.g., biasing the latch 28 in the first position). In the form illustrated, the first portion 28a has a bend of approximately eighty-five degrees and defines at least one bore for aligning with a corresponding bore in the base 24 so that the latch 28 may be connected thereto via a fastener.

[0034] The second portion 28b has a structure for mating with the body 22 to secure the body to the base 24 when it is disposed therein. In the form illustrated, the mating structure is a protrusion, such as a shoulder, extending from the latch 28 which prevents a portion of the body 22 from being removed from the opening 25 of base 24 when the latch 28 is in the first position. The protrusion 28b extends out from the first portion 28a at a ninety degree angle and provides a generally flat surface or edge against which the body 22 may be positioned. The protrusion then slopes back in towards the third portion 28c of the latch.

[0035] The slope formed by protrusion 28c allows the latch 28 to automatically move from the first position to the second position so that the body 22 can be secured to the base 24 without the need for an operator to manually move the latch 28 from the first position to the second position. More particularly, when the body is inserted into the opening 25 to be secured to the base 24, the body 22 or latch guard 30 (if present) engages the slope of the protrusion 28b and causes the latch 28 to move from the first position to the second position until the body 22 and guard 30 have cleared the edge of the protrusion 28b. Once the body 22 and guard 30 clear the protrusion 28c, the latch 38 is automatically returned to the first position due to the bend in first portion 28a, thereby securing the body 22 between the shoulder 24e and the flat surface or edge of protrusion 28b. This passive locking configuration allows the body 22 to be quickly secured to the base 24 without requiring additional steps, such as manually moving the latch 28 from the first position to the second position.

[0036] The third portion 28c extends from the second portion 28b and forms a handle or grip for actuating the latch 28. In the form illustrated, the third portion 28c includes a generally flat surface formed at the distal end of the latch 28 which the operator may use to manually move the latch

between the first and second positions. In view of the passive locking feature discussed above, the operator may use the operative end 28c to move the latch 28 from the first position to the second position when the body 22 is to be removed from the base 24. Once the body 22 and guard 30 have cleared the second portion 28b of latch 28, the latch 28 may be released and will automatically return to its latched or first position. In a preferred form, the third portion 28c provides a large generally flat surface upon which additional indicia may be placed. For example, the handle may be marked with a trademark or list the items or class of items that are attached to the body 22.

[0037] As mentioned above, the apparatus 20 may be provided with a hinge 26 which allows the side of the body 22 nearest the latch 28 to be pivoted or rotated out of the base 24. Any conventional hinge may be used, however, in the form illustrated in FIGS. 1A-D, the hinge 26 includes a first hinge component, such as hinge mount 32 (FIGS. 5A-6D), which is connected to the body 22, and a second hinge component, such as hinge receptacle 34 (FIGS. 7A-D), which is connected to the base 24. The hinge mount 32 has a generally U-shaped bracket 32a having a sleeve extending therefrom. More particularly, first and second arms 32b and 32c, respectively, extend from the bracket 32a and form respective circular sleeves 32d and 32e. A pin or rod 32f is inserted through the sleeves 32d-e and forms a bar with which the second hinge component 34 may mate. The bracket 32a may be mounted to the body using a conventional fastener. For example, in the form illustrated, the legs of the U-shaped bracket define two pairs of openings or bores. The openings on one leg align with corresponding openings on the other leg so that the bracket may be mounted to the body 22 via a bolt or rivet passing through the bracket from one leg to the other.

[0038] The second hinge structure 34 mates with the first hinge structure 32 so that the body 22 may be rotated with respect to the base 24. In the form illustrated, the second hinge structure 34 is a receptacle for receiving at least a portion of the bar formed by first hinge structure 32. More particularly, the receptacle 34 has a mating structure, such as hook 34a, for engaging the bar 32f of first hinge member 32, and a mount, such as mounting bracket 34b, for connecting the second hinge structure 34 to the base 24. The second hinge structure 34 is preferably made out of spring steel with the hook 34a extending from the bracket 34b at an angle less than ninety degrees. In the embodiment illustrated, the hook 34a extends from the bracket 34b at an eighty-five degree angle. This angle or bend forces the hook 34a into engagement with the first hinge component 32 and ensures that the body 22 will be firmly secured to the base 24 when inserted therein.

[0039] When the bar 32f is inserted into the hook 34a, the body 22 may be rotated about an axis defined by the bar 32f. Thus, when latch 28 is moved to the second position, the body 22 may be rotated out of the base 24 and preferably suspended therefrom. To remove the body 22 from the base 24, the operator simply needs to remove the bar 32f from the hook 34a. In the form illustrated, the distal end of the hook 34a is semi-circular in shape so that the bar 32f can be easily inserted therein or removed therefrom.

[0040] This configuration is useful for a variety of reasons. For example, by allowing the body 22 to rotate at least

partially out of the base **24**, the apparatus **20** makes it easier for an operator to view and select tools attached to the body **22**. For instance, if the base **24** is mounted to the wall or ceiling of a tool truck, the operator may actuate the latch **28** to pivot the body at least partially out of the base **24** so that he or she can better view and/or select the tools attached thereto. The rotation of the body **22** out of the base **24** may also lower the tools to an easier height for the operator to look at and/or select the tools from. By allowing the body **22** to be removed from the base **24**, the operator can quickly and easily transport tools from one location to another. Using the tool truck example from above, a salesman can readily remove the body **22** and transport some or all of the tools thereon from the tool truck and into a potential customer's place of business. The tray-like configuration of the body **22** further allows the tools to be easily displayed to the potential customer and returned to the truck after the meeting with the potential customer is over. The handle defined by the body **22** and opening **23**, make it easier to transport the tray of tools as well. Lastly, by allowing the body **22** to be rotated at least partially out of the base **24**, the apparatus **20** provides the user with more surface area to grab the body of tools. This is particularly helpful when dealing with heavier tools and/or when dealing with a body or tray **22** having a large number of tools connected thereto.

[0041] It should be understood that in alternate embodiments, the location of the hinge components may be reversed. For example, the hinge mount **32a** may be connected to the base **24** and the mating hinge structure **34** connected to the body **22**. Similarly, the latch **28** may be located on the body **22** rather than the base **24**. However, in this configuration, the base **24** will be designed with an edge for the protrusion **28c** to catch to secure the body to the base. In yet other embodiments, some of the components discussed above may be made integral to one another. For example, the mating hinge component **34** may be integrally formed in the base **24** rather than provided as a separate structure or bracket.

[0042] Thus, in operation, tools (not shown) may be connected to the body **22** via any conventional means, such as by using shock cord or the like, and stored in the base **24**. The tool and/or entire body **22** may be removed from the base **24** by simply moving the latch **28** into the second position thereby releasing an end of the body **22** so that it may be pivoted out from the base. The user may then simply remove the desired tools from the body **22** and rotate the body back into the base **24**, or may remove the entire body **22** to transport the tray of tools to a remote location.

[0043] An alternate embodiment of the tool storage system **20** is illustrated in FIGS. **9A-D** and includes a body connected to the base via a plurality of latches rather than a latch and hinge configuration. For convenience, items which are similar to those discussed above with respect to FIGS. **1A-8D** will be identified using the same reference numeral in combination with an apostrophe (') merely to distinguish one embodiment from the other. In the embodiment illustrated in FIGS. **9A-D**, the body **22'** is secured to the base **24'** via a first latch **28'** and second and third latches **36** and **38**, respectively. Like latch **28'**, latches **36** and **38** are movable between a first position wherein the latch secures a first portion of the body **22'** to the base **24'** and a second position wherein the latch releases the first body portion so that it may be removed from the base **24'**. Latches **36** and **38** also

have a similar construction to latch **28'** including a portion for mating with the body **22'** and a portion for mounting the latches **36** and **38** to the base **24'**. Noticeably absent, however, is a gripping portion or handle. The reason latches **36** and **38** do not have handle portions is that the operator need not move these latches into their second position in order to remove the body **22'** from the base **24'**. Rather, the operator can simply move latch **28'**, which is illustrated in detail in FIGS. **10A-10D**, to its second position to release a portion of body **22'** and then remove the remainder of body **22'** by sliding the remainder of the body out of latches **36** and **38**. In other embodiments, latches **36** and **38** may be provided with a gripping portion or handle if such a feature is desired.

[0044] FIGS. **11A-D** provide a variety of views of latch **36**, which is identical to latch **38**. As illustrated, latch **36** has a first portion **36a** that is generally L-shaped. The first portion **36a** is preferably bent at an angle less than ninety degrees in order to bias the latch **36** into engagement with the body **22'** (e.g., biasing the latch **36** into its first or latched position). The first portion **36a** further defines at least one opening or bore for aligning with a corresponding bore in the base **24'** so that the latch **36** may be connected thereto via a fastener such as a screw, bolt or rivet.

[0045] A second portion **36b** extends from the first portion **36a** and defines a mating structure for mating with the body **22'** to secure the body to the base **24'** when it is disposed therein. In the form illustrated, the second portion **36b** forms a protrusion, such as a shoulder, extending from the latch **36** which prevents a portion of the body **22'** from being removed from the opening **25'** of base **24'** when the latch **36** is in the first position. The protrusion **36b** extends out from the first portion **36a** at a ninety degree angle and provides a generally flat surface or edge against which the body **22'** may be positioned. The protrusion then slopes back in at an angle to allow the latch **36** to automatically move from the first position to the second position so that the body **22'** can be secured to the base **24'** without the need for an operator to manually move the latch **36** from the first position to the second position. Using this passive locking configuration, an operator can secure the body **22'** to the base **24'** by simply pressing the body **22'** against latches **28'**, **36** and **38**, thereby allowing the latches to move to their respective second positions and return to their respective first positions once the body **22'** has cleared the edge of each latch. Alternatively, the operator may insert an end of the body **22'** into latches **36** and **38** and press the opposite end of body **22'** into engagement with the main latch **28'**. Regardless of the manner in which body **22'** is inserted into the base **24'**, the body **22'** can be quickly snapped into place in the base **24'** without requiring additional steps, such as manually actuating any of the latches. Conversely, the body **22'** can be removed from the base by manually moving latch **28'** to its released position and pulling the body **22'** out of the base **24'**.

[0046] Although no guards are provided to protect the body **22'** from latches **28'**, **36** or **38** in the embodiment illustrated in FIGS. **9A-D**, it should be understood that guards, similar to guard **30**, may be attached to body **22'** to avoid wear associated with repeated latching and unlatching of the body via latches **28'**, **36** and **38**. The embodiment illustrated in FIGS. **9A-D** also illustrates three latches being used. It should be understood, however, that alternate embodiments may be used with fewer or more latches as

desired and the locations of the latches may be altered so long as the components achieve the same goal which is to secure the body to the base.

[0047] In the embodiments illustrated herein, the bodies are preferably made of a fiber board, such as a composite wood peg-board or a perforated fiberglass panel, the bases are preferably made of a polymer, such as plastic or rubber, the latches are preferably made of metal clips, such as spring steel clips, and the hinges are preferably made of a metal, such as steel. Various dimensions for these components are also provided in the attached drawings. However, it should be understood that these components may be provided in a variety of shapes and sizes in accordance with the invention. In yet another embodiment, the latches may be replaced with quarter turn fasteners, such as those provided by Southco, Inc. of Concordville, Pa. (USA).

[0048] Additionally, while the latches **28**, **28'** and **36** have been disclosed herein as including protrusions **28b**, **28b'**, and **36b**, respectively, for securing the body **22** within the base **24**, it should be appreciated that an alternate form of the latches **28**, **28'**, and **36** may include recesses adapted to secure the body **22** within the base **24**. So configured, the recesses may be formed similar to the protrusions **28b**, **28b'**, **36b** in that they could include a substantially flat portion and an angled portion. In fact, it may be envisioned that such recesses formed on the latches **28** and **28'** may be formed as identical mirror images of the protrusions illustrated in **FIGS. 4A-4D** and **10A-10D**. Additionally, the recess formed on the latch **36** may be formed as an identical mirror image of the protrusion **36b**. In any such event, the recesses would be utilized to receive an edge of the body **22** therein. The angled portion of the recess would assist the body **22** into complete insertion into the recess and the flat portion would lock the body **22** relative thereto. In yet other forms, the recesses may have an alternate configuration which is not necessarily similar to the protrusions disclosed herein but is capable of serving the principles of the present invention.

[0049] Further yet, it should be appreciated that while the above-described tool storage system **20** has been disclosed as accommodating tools on an exposed side of the body **22**, it is also envisioned that tools may be stored on the hidden side of the body **22** when the body is attached to the base **24**. So configured, the tools attached to the hidden side of the body **22** would be accommodated in the opening **25** of the base **24**. In one form, the step **24e** within the opening **25** is offset by a predetermined distance from a bottom of the opening, thereby providing sufficient room for storing the tools. Therefore, it should be understood and appreciated that such storage would enable a tool salesman to store and transport twice as many tools as compared to storing tools only on one side of the body **22**.

[0050] Finally, it should be appreciated that while dimensions for various features of the tool storage system **20** according to the various forms and embodiments of the present invention have been provided herein, a more detailed description of the dimensions of one form are provided in U.S. Provisional Application No. 60/643,848, filed Jan. 14, 2005, which the present application claims the benefit of and is hereby incorporated herein by reference in its entirety. Additionally, however, it should be appreciated that the dimensions so provided merely describe a single example of the present invention and alternate configura-

tions of the tool storage system **20** having different dimensions are intended to be within the scope of the claims.

What is claimed is:

1. A tool storage system comprising:

a body to which tools may be attached;

a base to which the body is removably fastened; and

a fastening mechanism for connecting the body to the base so that the body may be attached to the base or removed and used remote therefrom.

2. An apparatus according to claim 1 wherein the fastening mechanism comprises:

a hinge connected to the body and the base for providing an axis about which the body may be rotated with respect to the base; and

a latch connected to the base and movable between a first position wherein the latch secures the body to the base and a second position wherein the latch releases the body so that it may be removed from the base.

3. An apparatus according to claim 2 wherein the hinge comprises a plurality of hinges connected to a first side of the base and the latch comprises a spring clip connected to a second side of the base so that the body can be rotated about an axis defined by the plurality of hinges when the latch is in the second position.

4. An apparatus according to claim 3 wherein the plurality of hinges and spring clip latch are located on opposite sides of the base so that the body rotates away from the latch about the axis defined by the hinges when the latch is in the second position.

5. An apparatus according to claim 2 wherein the hinge comprises a first hinge component connected to the body and a second hinge component connected to the base, the first hinge component being removable from the second hinge component so that the body may be removed from the base.

6. An apparatus according to claim 5 wherein the first hinge component has a bar extending from the body and the second hinge component has a receptacle for receiving at least a portion of the bar to form the hinge about which the body may be rotated.

7. An apparatus according to claim 2 further comprising a guard connected to the body and positioned to engage at least a portion of the latch thereby preventing the latch from damaging the body.

8. An apparatus according to claim 7 wherein the latch and guard are made of metal.

9. An apparatus according to claim 1 wherein the fastening mechanism comprises:

a first latch connected to the base and movable between a first position wherein the latch secures a first portion of the body to the base and a second position wherein the latches releases the first body portion so that it may be removed from the base; and

a second latch connected to the base and movable between a first position wherein the latch secures a second portion of the body to the base and a second position wherein the latch releases the second body portion so that it may be removed from the base.

**10.** An apparatus according to claim 9 wherein the latches are spring clips that extend toward each other from opposite sides of the base.

**11.** An apparatus according to claim 9 further comprising a third latch connected to the base and movable between a first position wherein the third latch secures a third portion of the body to the base and a second position wherein the third latch releases the third body portion so that it may be removed from the base.

**12.** An apparatus according to claim 11 wherein the latches are spring clips with the first latch connected to a first side of the base and the second and third latches connecting to a second side of the base.

**13.** An apparatus according to claim 12 wherein the first and second sides of the base are opposite sides of the base.

**14.** A mobile tool platform, comprising:

a storage compartment fixedly mounted to the tool platform;

a quick-release mechanism supported by a portion of the storage compartment; and

a panel adapted to be detachably connected to the storage compartment via at least the quick-release mechanism and store and display at least a tool thereon.

**15.** The mobile tool platform of claim 14, wherein the quick-release mechanism includes a biased latch supported

by the storage compartment and moveable between a biased first position and a second position, wherein the latch is adapted to secure the panel to the storage compartment while in the first position and release the panel from the storage compartment while in the second position.

**16.** The mobile tool platform of claim 15, wherein the latch includes a protrusion adapted to engage the panel while in the first position, thereby securing the panel to the storage compartment.

**17.** The mobile tool platform of claim 15, further comprising a hinge having a first component fixed to the panel and a second component supported by the storage compartment, the first and second components adapted to interlock when the panel is secured to the storage compartment by the quick-release mechanism and provide a pivotal relationship between the panel and the storage compartment when the panel is unsecured therefrom.

**18.** The mobile tool platform of claim 14, further comprising a base supported by the storage compartment, the base including the quick-release mechanism.

**19.** The mobile tool platform of claim 18, wherein the base includes an opening within which the quick-release mechanism is adapted to secure the panel.

\* \* \* \* \*