

No. 681,712.

Patented Sept. 3, 1901.

P. KENNEDY.

MEANS FOR CONTROLLING ELECTRIC CURRENTS.

(Application filed Mar. 26, 1898. Renewed Apr. 1, 1901.)

(No Model.)

4 Sheets—Sheet 1.

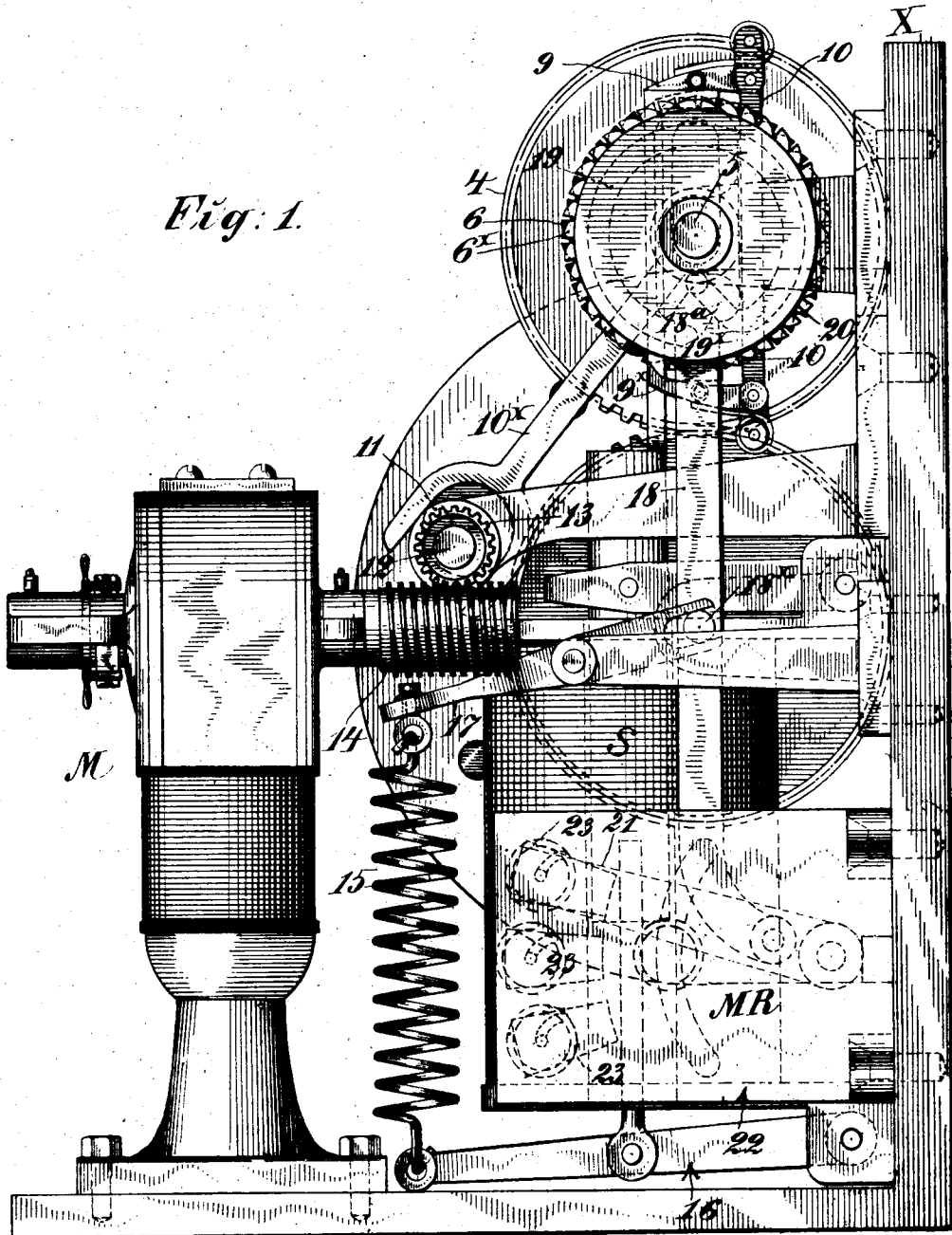

WITNESSES:  
*F. N. Roehrich*  
*J. H. Wiman*

INVENTOR  
*Patrick Kennedy*  
BY  
*Henry Comstock*  
ATTORNEY



P. KENNEDY.

MEANS FOR CONTROLLING ELECTRIC CURRENTS.

(Application filed Mar. 26, 1898. Renewed Apr. 1, 1901.)

(No Model.)

4 Sheets—Sheet 3.

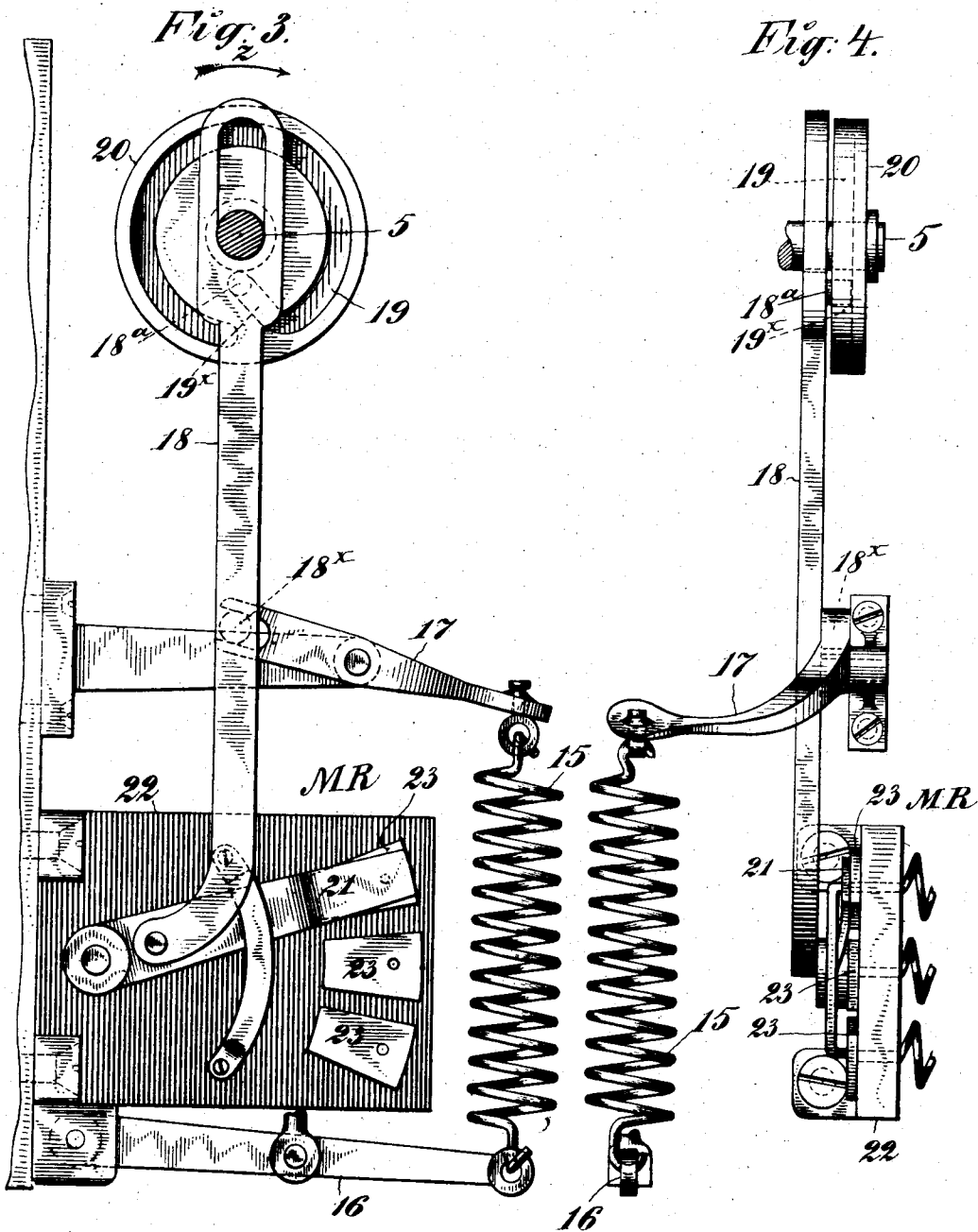

WITNESSES:  
*F. N. Roehrich*  
*J. H. Wiman*

INVENTOR  
*Patrick Kennedy*  
 BY  
*Henry Comstock*  
 ATTORNEY

P. KENNEDY.

MEANS FOR CONTROLLING ELECTRIC CURRENTS.

(Application filed Mar. 26, 1898. Renewed Apr. 1, 1901.)

4 Sheets—Sheet 4.

(No Model.)

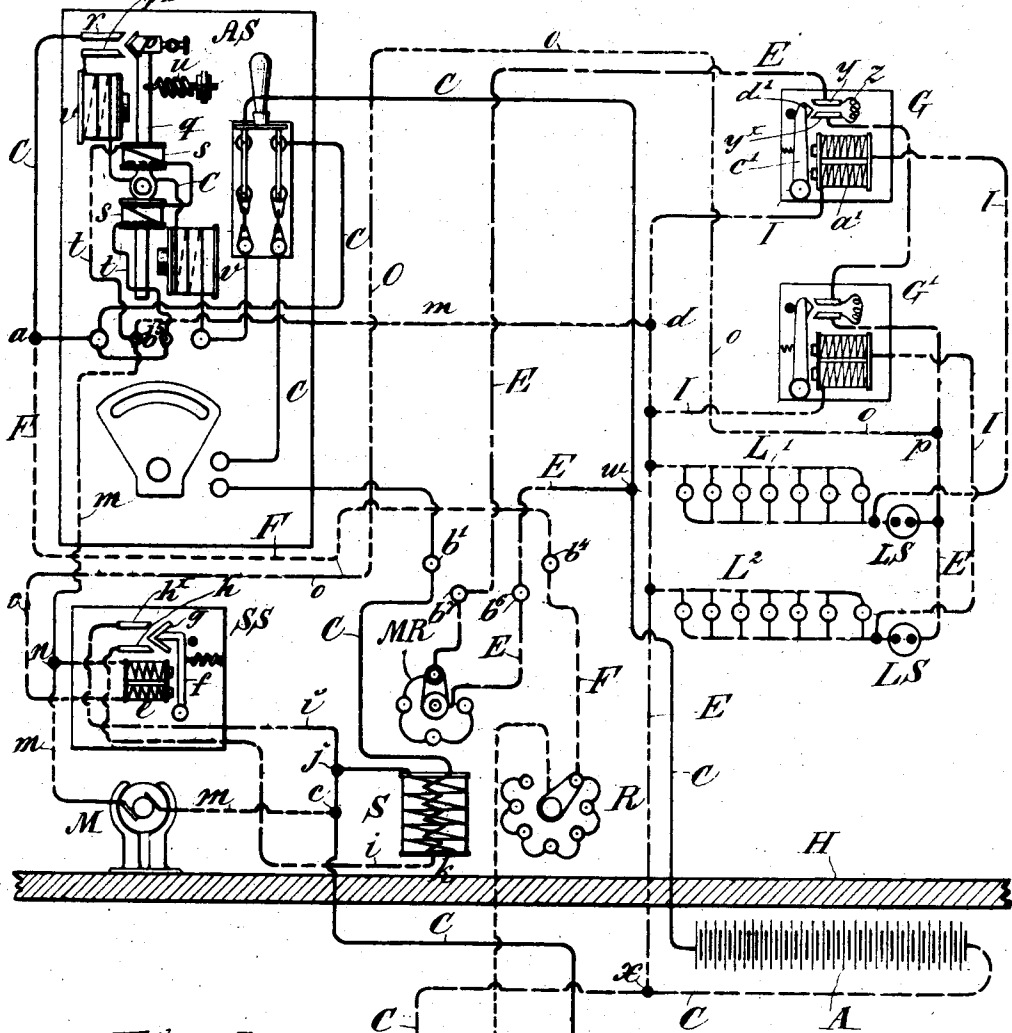
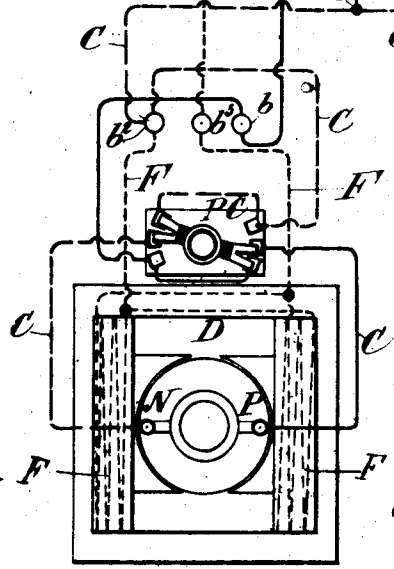

Fig. 5.



WITNESSES:  
*Fr. N. Roehrich*  
*L. N. Wiman*

INVENTOR  
*Patrick Kennedy*  
 BY  
*Henry Comets*  
 ATTORNEY

# UNITED STATES PATENT OFFICE.

PATRICK KENNEDY, OF BROOKLYN, NEW YORK, ASSIGNOR TO THE AMERICAN RAILWAY ELECTRIC LIGHT CO., OF WEST VIRGINIA.

## MEANS FOR CONTROLLING ELECTRIC CURRENTS.

SPECIFICATION forming part of Letters Patent No. 681,712, dated September 3, 1901.

Application filed March 26, 1898. Renewed April 1, 1901. Serial No. 53,945. (No model.)

*To all whom it may concern:*

Be it known that I, PATRICK KENNEDY, a citizen of the United States, residing in the borough of Brooklyn, in the county of Kings and city and State of New York, have invented certain new and useful Improvements in Means for Controlling Electric Currents, of which the following is a specification.

This invention relates to means or devices for controlling electric currents generated by a dynamo, and especially to such means when used in connection with a dynamo and an external circuit fed by said dynamo and containing an accumulator and a series of lamps under circumstances where the dynamo is subject to variations in speed, as in car-lighting, or where the dynamo is driven from a windmill.

The purpose of the invention is in the main to provide automatic means for regulating the current in the exterior circuit fed by the dynamo in order to maintain said current substantially uniform and to adapt it automatically to altered conditions, all as will be hereinafter fully described with reference to the accompanying drawings, illustrating the invention.

In the drawings, Figure 1 is a side elevation of the mechanism for varying the resistance thrown into the coils of the field-magnets of the dynamo, and Fig. 2 is a front view of the same. Figs. 3 and 4 are detail views of the mechanism for automatically throwing a resistance into the lamp-circuit for reasons that will be hereinafter explained. Fig. 5 is a diagrammatic view showing the circuits, automatic switches, &c.

Before proceeding to minutely describe my present invention I will call attention to the United States Patent No. 594,744, granted to me November 30, 1897, for means for controlling electric currents, as some of the mechanisms described in that patent are used in connection with the improvements embodied in the present application, and those features shown in the former patent are not fully illustrated herein. In my said Patent No. 594,744 there is shown a dynamo, a solenoid, the coil of which is in the main circuit, fed by said dynamo, a resistance box or rheostat containing coils in circuit with the coils of the

field-magnet of the dynamo, and a ratchet device (similar to that shown herein) controlled by the movable core of the solenoid for putting more or less resistance into the field-magnet coils, according to the strength of the main current supplied by the dynamo. In said patent the reciprocating pawls, which form a part of the ratchet mechanism, are driven directly from the armature-shaft of the dynamo, while in the present invention these pawls are driven, in the case of a car-lighting plant, by a small electric motor driven from said dynamo. In the said patent electromagnetic means were provided for putting tension on the spring, which resists the movement of the solenoid-core, but in the present case other means are provided for this purpose, as will be explained.

The invention will now be described, and its novel features carefully defined in the claims.

In Fig. 5, D designates the dynamo which furnishes the current; F, the field-magnets thereof; S, the solenoid; R, the rheostat; A, the accumulator or storage battery, in multiple in the main exterior circuit, fed by the dynamo; L' L<sup>2</sup>, series of lamps in multiple in the main circuit, and L S switches which switch in the several series of lamps. A S represent an automatic switch which when the generator is not operating cuts the latter out from the lamp-circuit, leaving the lamps to be supplied from the accumulator only. S S' represent an automatic switch which serves to shunt out or short-circuit a part of the coil of the solenoid when the lamps are in operation, thus necessitating a greater amount of current flowing through the solenoid-coil to overcome the resistance of the solenoid-spring. M is the small motor which actuates the pawls of the ratchet device, and P C represent an automatic pole-changer used on cars to adapt the electrical devices to the car in whichever direction the latter may be moving. This may be the same pole-changing device that is illustrated and claimed in my former patent.

Referring to Figs. 1 and 2, R is a rheostat such as that described in my former patent and consisting of a fixed disk 1 and a contact-finger 2, secured on a shaft 3, mounted

in a bearing on a suitable frame X to rotate concentrically with said disk. This shaft is geared by wheels 4 (for convenience only) to a shaft 5, which carries the two reversed ratchet-wheels 6 and 6<sup>x</sup>. S is the solenoid, the core 7 of which carries pawl-detachers 8 and 8<sup>x</sup>, which serve to detach, respectively, the spring-pawls 9 and 9<sup>x</sup> from the teeth of the respective ratchet-wheels 6 and 6<sup>x</sup>. These pawls are pivoted on the respective upper and lower ends of a rocker 10, mounted to rock on the shaft 5, so as to reciprocate the pawls alternately. The rocker 10 has an operating-arm 10<sup>x</sup>, with a fork at its free end, within which rotates an eccentric 11, fixed on a shaft 12, mounted in bearings on the frame X. Rotation of this shaft imparts vibrating motion to the rocker 10, and through it motion to the pawls, so that the pawl that happens to be engaged with its ratchet-wheel will rotate the contact-finger 2 over the disk 1 in one direction. The movement of the core of the solenoid S up or down determines in which direction the finger 2 shall move over the terminals on the disk. This construction of the rheostat and ratchet device is substantially the same as that described in my former patent; but where the device is to be used in car-lighting it may be desirable to actuate this mechanism by some other means than the arbor of the dynamo-armature, and therefore as a means for driving the shaft 12 a worm-wheel 13 on this shaft is made to gear, Fig. 1, with a worm 14 on the arbor or shaft of the armature of the small motor M, and this latter may be driven by a circuit derived from the main circuit fed by the dynamo D and accumulator A, as will be hereinafter explained.

I will now describe the means herein employed for maintaining the tension of the spring 15, which resists the downward movement of the core 7 of the solenoid S. The said core is coupled to a lever 16, fulcrumed at one end to the frame X, and to the outer end of this lever is coupled the lower end of the spring 15. The upper end of said spring is coupled to one arm of a lever 17, the other arm thereof being forked or slotted and engaging a stud 18<sup>a</sup> in an upright operating-rod 18. At its upper end this rod has a slotted guide-bearing, Fig. 3, on the shaft 5 and carries a stud 18<sup>a</sup>, which engages a cam-groove 19 in a cam-disk 20, fixed on the end of said shaft 5. The main portion of this groove 19 is concentric; but at that end of it which may be termed the "beginning" it has an abrupt inclined portion 19<sup>x</sup>, (seen in dotted lines in Fig. 3,) which extends in obliquely toward the center of the disk 20. Now when the parts are at rest, as in Figs. 3 and 4, there is little tension on the spring 15, and it will be obvious that the tension of said spring will mark the limit which the strength of the current flowing through the solenoid must reach before resistance is thrown into the field-magnet circuit. The greater this tension the

stronger must be the current to overcome it. In some cases, however, it is desirable to automatically reduce the tension of the current to a considerable degree—as, for example, when all the lamps are turned off. This is the position of the parts shown in Figs. 3 and 4. When the current begins to flow through the exterior circuit, the cam-disk 20 is rotated in the direction of the arrow *z* in Fig. 3 and the wall of the inclined portion 19<sup>x</sup> of the cam-groove 19 acts on the stud 18<sup>a</sup> to force down the operating-rod 18, and this acts on the lever 17 to put tension on the spring 15. When the stud 18<sup>a</sup> shall have entered the concentric portion of the cam-groove 19, the tension on the spring 15 will be maintained during the further rotation of the disk 20. While the shaft 5 is rotating to an extent sufficient to put the tension on the spring 15—that is, during the rotary movement of the disk 20 at the beginning far enough to put the stud 18<sup>a</sup> into the concentric part of the cam-groove 19—no resistance will be put in the field-magnet circuit. The depression of the operating-rod 18 has another function, which will now be described.

In Figs. 3, 4, and 5, M R represent a resistance or rheostat in the main circuit, this rheostat comprising in Fig. 3 an arm or finger 21, pivoted to a plate 22, mounted on the frame X and coupled to the lower end of the rod 18, so that as this rod is depressed by the cam-groove 19<sup>x</sup> said finger moves over the contact-terminals 23, thus switching one or more resistance-coils into the main circuit. The purpose of this will be explained. In this system, which employs lamps of high efficiency and low voltage, as the electromotive force in charging the accumulator is usually in excess of that in discharging this resistance M R is put in the main circuit between the accumulator A and the lamps. This enables the voltage in the circuit between the dynamo and the accumulator to be maintained without danger of burning out the lamps.

The circuits, switches, &c., shown in Fig. 5 will now be explained, premising that the instalment is supposed to be on a car for lighting the same and that H represents the bottom or floor of the car, the dynamo, pole-changer, and accumulator being below the same. The positive or outgoing side of the main circuit C (represented by an unbroken line) leaves the positive brush P of the dynamo D, passes to and through the pole-changer P C, thence to a binding-post *b*, thence to and through the coil of the solenoid S, thence to a binding-post *b'*, thence to the automatic switch A S, and thence, when this switch is closed, to one terminal of the accumulator A. The negative or return portion of the main circuit C (represented by dashes) leaves the other terminal of the accumulator, extends thence to a binding-post *b*<sup>2</sup>, and thence to and through the pole-changer to the negative brush N of the dynamo. The

field-magnet circuit F is represented by short dashes. Its positive side passes to a binding-post  $b^2$ , thence to and through the rheostat R, thence to a binding-post  $b^4$ , and thence to the point  $a$ , where it joins the positive of the main circuit C. The negative side of the field-magnet circuit joins the negative side of the main circuit at the binding-post  $b^2$ . The branch circuit  $m$  through the motor M leaves the main positive circuit at  $c$ , its positive side being represented by a long dash and three short dashes. The negative portion (represented by a long dash and four short dashes) leaves the motor and passes thence to a binding-post  $b^5$  at the switch A S. From this point it passes to the negative side of the lamp-circuit at  $d$ . The switch S S, (seen on a large scale in Fig. 2,) which is adapted to shunt out one-half of the coil of the solenoid S, consists of an electromagnet  $e$ , an armature  $f$ , carrying a contact-piece  $g$ , and two terminals  $h$  and  $h^x$ . The shunt-circuit  $i$  (designated by two long and two short dashes) leaves the main circuit C at  $j$  and extends to the terminal  $h^x$ , and from the other terminal  $h$  it extends to the middle part of the solenoid-coil at  $k$ . The magnet  $e$  is connected on one side with the motor-circuit  $m$  at  $n$  and on the other side by a wire  $o$  with the positive side of the lamp-circuit at  $p$ . When the current in the main circuit becomes strong enough, the magnet  $e$  attracts the armature  $f$ , connects the two terminals  $h$  and  $h^x$ , and shunts out the outer half of the coil of the solenoid S.

The switch A S will now be described. There is a break in the positive side of the main circuit C at the two switch-terminals  $r$  and  $r^x$ , which break is adapted to be closed by a contact-piece  $p$  on a pivoted armature  $q$ . On this armature are two bobbins  $s$ , the coils of which are in a branch  $t$  from the main circuit. When the dynamo is set in motion and the current in the circuit  $t$  becomes strong enough, the spring  $u$ , behind the armature  $q$ , is overcome and the armature swings toward the poles of two magnets  $v$ , whose coils are in the main circuit C. This has the effect to close the main circuit at the terminals  $r$  and  $r^x$ , and the pull of the magnets  $v$  holds it closed. The positive side of the lamp-circuit E leaves the main circuit C at  $w$  and is designated by two long dashes and a short one. It extends thence to a binding-post  $b^6$ , thence to the main rheostat M R, thence to a binding-post  $b^7$ , thence through automatic resistance devices G G', one for each set of lamps, and thence to the lamps. The negative side of the lamp-circuit E is represented by one long dash and two short ones. It connects with the negative side of the main circuit at  $x$ . It is desirable that when a set of lamps, as L', is turned off a resistance be put in the lamp-circuit to compensate for the rise in the electromotive force of the accumulator and for the quantity of the discharging-current which has been reduced by cutting out these lamps, thereby

preventing the rapid deterioration of the lamps. This end is attained by putting into the lamp-circuit a resistance for each set of lamps and providing means for automatically shunting out such resistance when the set of lamps corresponding thereto is turned on, the resistance being again automatically switched in when that set of lamps is turned off at its switch. Such a device is seen at G in Fig. 5, and it comprises an electromagnet  $a'$ , an armature  $c'$ , carrying a contact-piece  $d'$ , two terminals  $y$  and  $y^x$  in the positive side of the lamp-circuit E, and a resistance  $z$ , connecting the two terminals  $y$  and  $y^x$ . When a set of lamps, as L', is turned off, the current in the lamp-circuit flows through the resistance  $z$ ; but when the lamps are turned on at the switch L S a current is established through a branch I of the lamp-circuit, which includes the coils of the electromagnet  $a'$ . The latter is excited, attracts the armature  $c'$ , puts the piece  $d'$  in contact with the terminals  $y$  and  $y^x$ , and thus shunts out the resistance  $z$ . Two sets of lamps are shown, each provided with such a shunting device; but any number of sets of lamps may be employed, each having a device like the devices G and G'. It will be understood that at starting the dynamo, the accumulator A being charged, when the electromotive force of the dynamo shall have risen sufficiently to overcome the electromotive force of the accumulator the automatic switch A S will operate to close the main circuit of the dynamo and accumulator. When the lamps are on, it becomes necessary to develop a greater current than when the dynamo is charging the accumulator alone, and this feature of the regulation is effected by the operation of the switch S S, which shunts out or short-circuits one-half or some proportion of the coil of the solenoid, whereby a much stronger current is required therein to put into the field-magnet circuit the same resistance as before. When the lamps are on and the dynamo is not in operation, the switch A S will be open and the lamp-circuit will be fed from the accumulator. The regulator can, for example, be adjusted to maintain a constant current from the dynamo for any electromotive force between thirty and sixty volts, and the automatic switch can also be adjusted for operation at any electromotive force between these points.

The operation and purpose of the device seen in Figs. 2 and 4 will now be explained. When the dynamo is not running and the switch A S is open, the tension of the spring 15 will be at its minimum, and by reason of the position of the stud 18<sup>a</sup> in the cam-groove 19 the resistance in the lamp-circuit at the rheostat M R will be entirely cut out. Now when the dynamo is set in motion and has reached a speed sufficient to furnish an electromotive force high enough to overcome the electromotive force of the accumulator the automatic switch A S will close the main circuit and the slight current flowing through

the solenoid-coil will draw down the core of the solenoid, and thereby allow one of the pawls to engage its ratchet, thus throwing a portion of the resistance M R into the lamp-circuit and at the same time increasing the tension on the spring 15 of the solenoid and moving the core of the latter upward, so as to lift the operating-pawl free from its ratchet-wheel and arrest further action by the pawl until the increase in speed of the dynamo has increased the current to a point sufficient to overcome the tension of the solenoid-spring, when the core of the solenoid again sets the pawl in action, and this will take place successively until all the resistance at the rheostat M R is thrown into the lamp-circuit and the tension on the solenoid-spring has reached the maximum. The stud 18<sup>a</sup> will now have entered the concentric part of the cam-groove 19 and no further effect will be produced on the spring 15 and resistance M R in the lamp-circuit. A further acceleration in the speed of the dynamo increases the current, and this acts through the solenoid and its core to rotate the shaft 5, and thus throw some resistance into the field-magnet circuit at the rheostat R, thereby cutting down the current flowing through the solenoid, which reacts on the ratchet mechanism to regulate the current. When the speed of the dynamo is diminished, a reverse action takes place step by step, the cam-disk 20 now rotating backward until the stud 18<sup>a</sup> enters the portion 19<sup>x</sup> of the cam-slot in the disk and comes finally to the position seen in Fig. 3. In this position all the resistance at M R will be cut out and the spring 15 will be at its minimum tension again. When the stud 18<sup>a</sup> is at the respective ends of the cam-groove in the disk 20, the ratchet-wheels 6 and 6<sup>x</sup> will present, respectively, to their pawls untoothed or smooth peripheries. This prevents the pawls from acting when they can no longer rotate the shaft 5. The object in shunting out some portion of the solenoid-coil by the switch S S is to permit the use of a dynamo of sufficient capacity to furnish all the current required for the lamps in use and also, if necessary, to give the accumulators the maximum predetermined charging-current, and then when the lamps are not in use and the dynamo is in operation the accumulator will not have to receive an excessive charging-current, because the solenoid-coil not being shunted a smaller amount of current will serve to counteract the tension of the spring 15, and therefore the proper resistance will be automatically thrown in the field-magnet circuit by the amount of current required for the accumulator and lamps. It is well known that an excessive charging-current forced through an accumulator or storage battery is destructive to the elements of the battery, and hence a provision which limits the amount of current to the maximum charging-current for the storage battery becomes inoperative in a system of this kind, where a dynamo is employed

to charge a storage battery and supply-lamps at the same time, and which when the lamps are not in use supplies the storage battery alone.

Having thus described my invention, I claim—

1. In a device for controlling electric currents, the combination with a dynamo, a main exterior circuit fed by said dynamo, an accumulator in said circuit, a series of lamps in parallel in a branch of said circuit, a solenoid S in the said circuit, a field-magnet circuit F, a rheostat R in said circuit, mechanism controlled by the core of said solenoid and operating the finger of said rheostat, and an automatic switch S S which short-circuits a part of the coil of the solenoid when the lamps are turned on, substantially as set forth.

2. In a device for controlling electric currents for lighting, the combination with a dynamo, an exterior circuit fed by said dynamo, an accumulator in said circuit, and a series of lamps in a branch of said circuit beyond the accumulator, of a resistance or rheostat M R in said lamp-circuit between the lamps and the accumulator, and a cam device for putting said resistance automatically into the circuit when the current begins to flow through the outer circuit, thus enabling the voltage in the circuit between the dynamo and accumulator to be maintained without danger to the lamps, said cam device comprising a rotating cam, and a rod coupled to the arm of the rheostat and connected with said cam for operation, substantially as set forth.

3. In a device for controlling electric currents, the combination with the dynamo, an exterior circuit fed by said dynamo, the field-magnet circuit of the dynamo, a rheostat R in said field-magnet circuit, a ratchet mechanism for operating the finger of said rheostat, and a solenoid S, the core of which controls said ratchet mechanism, of the motor M, geared to and operating said ratchet mechanism, a branch circuit from the main circuit and through said motor for driving the latter, and an automatic switch in a branch of the main circuit which shunts out a part of the solenoid-coil when the current in the main circuit reaches a predetermined strength, substantially as set forth.

4. In a device for controlling electric currents, the combination with a dynamo, an exterior circuit fed by said dynamo, an accumulator in said circuit, a series of lamps in parallel in a branch of said circuit beyond the accumulator, an automatic switch A S, controlling a break in the main circuit between the dynamo and the accumulator; a rheostat M R in the circuit between the lamps and accumulator, whereby the voltage in the circuit between the dynamo and the accumulator may be maintained without injury to the lamps, and a rotating cam and a cam-rod for operating the arm of said rheostat, substantially as set forth.

5. In a device for controlling electric currents, the combination with a dynamo, an exterior circuit fed by said dynamo, a series of lamps in parallel in a branch of said circuit, and a switch to turn the said lamps on and off, of a resistance in circuit with said series of lamps, and an electromagnetic switch, in a branch of the lamp-circuit and adapted to shunt out said resistance automatically when the lamps are switched on, substantially as set forth.

6. In an electric-current regulator, the combination with the dynamo, the exterior circuit fed thereby, the solenoid S in said circuit, the solenoid-spring 15, the rotating shaft 5, carrying the cam-disk 20, having in it the cam-groove 19, 19<sup>x</sup>, the said cam-disk, the slide-bar 18 having a stud engaging said cam-groove, the lever 17, one arm of which is coupled to the solenoid-spring and the other to said slide-bar, whereby the depression of said bar puts tension on said spring, and the ratchet mechanism, substantially as described, for imparting rotation to the shaft 5.

7. In an electric-current regulator, the combination with a dynamo, an exterior, lamp-circuit fed by said dynamo, lamps in parallel in said circuit, a rotatable shaft 5, a ratchet mechanism substantially as described for rotating said shaft, a cam-disk 20, fixed on said shaft and having in it a cam-groove 19, 19<sup>x</sup>, and a slide-bar 18, having a stud which engages the said cam-groove, of the rheostat MR in the lamp-circuit, its arm being coupled to said slide-bar for operation thereby, substantially as set forth.

8. In a system for lighting or analogous purposes having as a source of current an in-

termittently-operated dynamo, a circuit containing a storage battery and the translating devices, means for connecting the dynamo with said circuit after it has reached a speed sufficient to develop an electromotive force substantially equal to that of the battery, means for gradually increasing the resistance of the translating-device circuit up to a predetermined point in response to further increase in the electromotive force of the dynamo without correspondingly increasing the resistance in the dynamo-circuit; and means for subsequently increasing the resistance in the dynamo-circuit, substantially as set forth.

9. In a system for lighting or analogous purposes having as a source of current an intermittingly-operated dynamo, a circuit containing a storage battery and the translating devices, means for connecting the dynamo with said circuit after it has reached a speed sufficient to develop an electromotive force substantially equal to that of the battery, a rheostat having a traveling member and resistance-coils in the translating-device circuit, and resistance-coils in the dynamo field-circuit, the translating-device resistance being in advance of the dynamo-resistance in the direction of travel of said traveling member; and means for operating said traveling member in response to an increase of electromotive force of the dynamo.

In witness whereof I have hereunto signed my name, this 23d day of March, 1898; in the presence of two subscribing witnesses.

PATRICK KENNEDY.

Witnesses:

HENRY CONNETT,  
PETER A. ROSS.