



US00D859233S

(12) **United States Design Patent**
Izard et al.

(10) **Patent No.:** **US D859,233 S**

(45) **Date of Patent:** **** Sep. 10, 2019**

(54) **VEHICLE GRILLE**
(71) Applicant: **GM GLOBAL TECHNOLOGY OPERATIONS LLC**, Detroit, MI (US)

(72) Inventors: **Brian M. Izard**, Northville, MI (US);
Benjamin Wilkins, Royal Oak, MI (US)

(73) Assignee: **GM GLOBAL TECHNOLOGY OPERATIONS LLC**, Detroit, MI (US)

(**) Term: **15 Years**

(21) Appl. No.: **29/654,204**

(22) Filed: **Jun. 21, 2018**

(51) **LOC (12) Cl.** **12-16**

(52) **U.S. Cl.**
USPC **D12/163**

(58) **Field of Classification Search**
USPC D12/169, 196, 86, 90-92, 163, 190, 98,
D12/164; 293/102, 113, 115, 117, 120,
293/193.11; 296/180.1, 180.2; 180/68.1,
180/68.6
CPC B60R 19/52; B60K 11/08; B62D 25/08;
B62B 9/16
See application file for complete search history.

D605,977 S	12/2009	Zipfel et al.
D605,978 S	12/2009	Wolff et al.
D608,249 S	1/2010	Peters
D608,690 S	1/2010	Folden et al.
D608,691 S	1/2010	Zak, Jr. et al.
D609,608 S	2/2010	Boniface et al.
D611,387 S	3/2010	Thompson et al.
D611,879 S	3/2010	Kim et al.
D612,297 S	3/2010	Peters et al.
D613,645 S	4/2010	Song et al.
D615,458 S	5/2010	Thompson et al.
D618,595 S	6/2010	Ware et al.
D623,090 S	9/2010	Cox et al.
D627,262 S	11/2010	Ikeda et al.
D635,488 S	4/2011	Phipps
D644,147 S	8/2011	Suh et al.
D644,567 S	9/2011	Kozub
D657,718 S	4/2012	Zipfel et al.
D659,052 S	5/2012	Ware et al.
D659,053 S	5/2012	Ware et al.
D668,182 S	10/2012	Barba Franco et al.
D668,183 S	10/2012	Smart
D678,820 S	3/2013	Son et al.
D678,821 S	3/2013	Ikeda et al.

(Continued)

Primary Examiner — Melody N Brown

(57) **CLAIM**

The ornamental design for a vehicle grille, as shown and described.

DESCRIPTION

FIG. 1 is a front and left side perspective view of a vehicle grille showing our new design;
FIG. 2 is a front view thereof;
FIG. 3 is a left side elevation view thereof, the right side being substantially a mirror image of the left side shown; and,
FIG. 4 is a top view thereof.
The broken lines in the drawings illustrate portions of the vehicle grille that form no part of the claimed design.

1 Claim, 4 Drawing Sheets

(56) **References Cited**
U.S. PATENT DOCUMENTS

D570,742 S	6/2008	Takagi et al.
D592,105 S	5/2009	Dean et al.
D597,447 S	8/2009	Folden
D600,595 S	9/2009	Nakamura et al.
D601,925 S	10/2009	O'Donnell
D603,755 S	11/2009	Peters
D604,203 S	11/2009	O'Donnell
D605,082 S	12/2009	Munson
D605,083 S	12/2009	Manoogian, II et al.

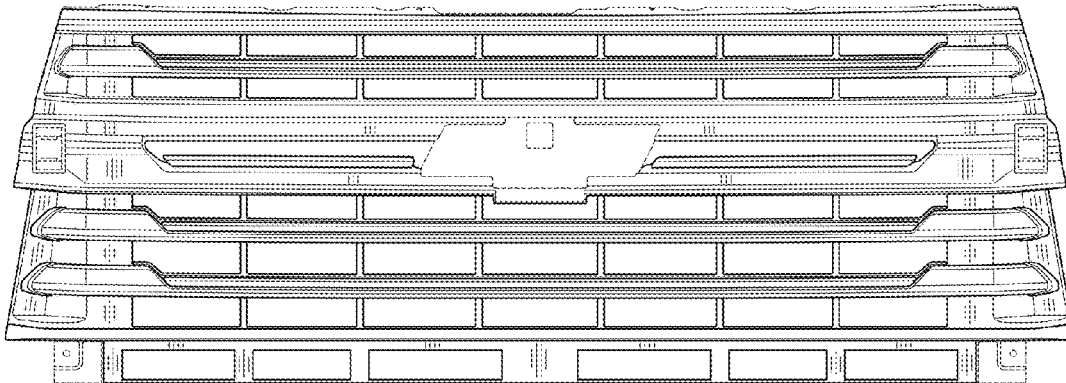

(56)

References Cited

U.S. PATENT DOCUMENTS

D680,909 S	4/2013	Munson et al.	D753,560 S	4/2016	McMahan et al.
D680,910 S	4/2013	David	D753,567 S	4/2016	Boniface et al.
D684,899 S	6/2013	Baker	D754,571 S	4/2016	Boniface et al.
D686,536 S	7/2013	McCabe et al.	D754,572 S	4/2016	McMahan et al.
D692,798 S	11/2013	Thurber	D755,088 S	5/2016	McMahan et al.
D692,799 S	11/2013	Smith et al.	D756,869 S	5/2016	McMahan et al.
D696,157 S	12/2013	Loeb	D758,271 S	6/2016	McMahan et al.
D699,629 S	2/2014	Ikeda et al.	D764,975 S	8/2016	Aengenheyster
D700,871 S	3/2014	O'Donnell et al.	D764,976 S	8/2016	Aengenheyster
D703,103 S	4/2014	Lee	D767,449 S	9/2016	Pevovar et al.
D704,103 S	5/2014	Mack et al.	D767,450 S	9/2016	Lee et al.
D705,132 S	5/2014	Ware et al.	D767,451 S	9/2016	Kozub et al.
D705,699 S	5/2014	Ware et al.	D767,454 S	9/2016	McMahan et al.
D713,298 S	9/2014	Dyson	D767,458 S	9/2016	Kim
D713,764 S	9/2014	Ferlazzo et al.	D767,459 S	9/2016	Kim
D716,696 S	11/2014	Thole et al.	D767,460 S	9/2016	Kozub et al.
D716,706 S	11/2014	Thole et al.	D767,461 S	9/2016	Kozub et al.
D716,709 S	11/2014	Thole et al.	D771,528 S	11/2016	Smith et al.
D717,696 S	11/2014	Thole et al.	D771,529 S	11/2016	Thole et al.
D718,189 S	11/2014	Krieg et al.	D771,532 S	11/2016	Kapitonov
D718,683 S	12/2014	Thole et al.	D771,533 S	11/2016	Kapitonov
D722,282 S	2/2015	Loeb	D772,766 S	11/2016	Kozub et al.
D722,533 S	2/2015	Thole et al.	D772,767 S	11/2016	Kim
D722,534 S	2/2015	Munson et al.	D773,084 S	11/2016	Kapitonov
D724,510 S	3/2015	McMahan et al.	D773,086 S	11/2016	McCabe et al.
D725,001 S	3/2015	McMahan et al.	D774,226 S	12/2016	McCabe et al.
D726,591 S	4/2015	Jacob	D775,003 S	12/2016	Pevovar et al.
D730,776 S	6/2015	Smart	D775,007 S	12/2016	Thole et al.
D730,783 S	6/2015	Henriques et al.	D775,010 S	12/2016	Kim et al.
D732,427 S	6/2015	Loeb	D775,049 S	12/2016	Scheer et al.
D732,429 S	6/2015	Loeb	D775,549 S	1/2017	Karras
D732,430 S	6/2015	Loeb	D775,554 S	1/2017	Kapitonov
D732,431 S	6/2015	Loeb	D776,020 S	1/2017	Kapitonov
D732,432 S	6/2015	Aengenheyster	D776,581 S	1/2017	Pevovar et al.
D732,433 S	6/2015	Aengenheyster	D776,583 S	1/2017	Scheer et al.
D732,435 S	6/2015	Mackay	D776,841 S	1/2017	Kozub et al.
D733,002 S	6/2015	Loeb	D776,843 S	1/2017	McCabe et al.
D735,611 S	8/2015	Aengenheyster	D776,846 S	1/2017	Willett et al.
D735,627 S	8/2015	Smith	D777,359 S	1/2017	Kozub et al.
D736,451 S	8/2015	Smith	D777,360 S	1/2017	Kozub et al.
D739,306 S	9/2015	McMahan et al.	D777,361 S	1/2017	Kozub et al.
D739,317 S	9/2015	McMahan et al.	D777,604 S	1/2017	McNerney
D741,223 S	10/2015	Kim et al.	D777,605 S	1/2017	Ferlazzo et al.
D743,309 S	11/2015	Thole et al.	D777,620 S	1/2017	Pevovar et al.
D743,313 S	11/2015	Smith et al.	D777,621 S	1/2017	Kim
D743,314 S	11/2015	Thole et al.	D777,622 S	1/2017	Kozub et al.
D743,857 S	11/2015	McMahan et al.	D777,628 S	1/2017	Kozub et al.
D744,158 S	11/2015	Willett et al.	D777,955 S	1/2017	Willett et al.
D745,086 S	12/2015	Finos et al.	D778,212 S	2/2017	Kozub et al.
D745,719 S	12/2015	Boniface et al.	D778,215 S	2/2017	Kozub et al.
D745,725 S	12/2015	McMahan et al.	D780,064 S	2/2017	Smith et al.
D745,726 S	12/2015	McMahan et al.	D780,067 S	2/2017	Zipfel et al.
D745,837 S	12/2015	Smith et al.	D780,068 S	2/2017	Whitla et al.
D746,726 S	1/2016	Smith et al.	D780,077 S	2/2017	Kim et al.
D746,727 S	1/2016	Smith et al.	D780,081 S	2/2017	Lee
D746,728 S	1/2016	Smith et al.	D780,084 S	2/2017	Scheer et al.
D746,729 S	1/2016	Boniface et al.	D780,631 S	3/2017	Kozub et al.
D746,730 S	1/2016	Kim et al.	D780,644 S	3/2017	Kim et al.
D747,514 S	1/2016	McMahan et al.	D781,184 S	3/2017	Thole et al.
D747,515 S	1/2016	McMahan et al.	D781,192 S	3/2017	Kozub et al.
D747,819 S	1/2016	Thole et al.	D782,379 S	3/2017	Wassell
D749,021 S	2/2016	Boniface et al.	D783,482 S	4/2017	Smith et al.
D749,026 S	2/2016	Smith et al.	D784,213 S	4/2017	Karras
D749,027 S	2/2016	McMahan et al.	D784,223 S	4/2017	Lee
D749,246 S	2/2016	Thole et al.	D784,226 S	4/2017	Cheng
D749,249 S	2/2016	Thole et al.	D784,579 S	4/2017	Cheng et al.
D749,250 S	2/2016	Thole et al.	D784,877 S	4/2017	Lee
D749,985 S	2/2016	Kozub et al.	D784,886 S	4/2017	Smith et al.
D749,997 S	2/2016	McMahan et al.	D785,521 S	5/2017	Smith et al.
D750,001 S	2/2016	Thole et al.	D786,149 S	5/2017	Pevovar et al.
D753,032 S	4/2016	Smith et al.	D786,743 S	5/2017	Smith et al.
D753,033 S	4/2016	Thole et al.	D786,750 S	5/2017	Lee
D753,034 S	4/2016	Thole et al.	D787,446 S	5/2017	Cockerill
D753,035 S	4/2016	Boniface et al.	D787,984 S	5/2017	Fang
D753,559 S	4/2016	McMahan et al.	D787,988 S	5/2017	Lee
			D787,989 S	5/2017	Kozub et al.
			D787,990 S	5/2017	Kozub et al.
			D787,992 S	5/2017	Lee
			D787,993 S	5/2017	McCabe et al.

(56)

References Cited

U.S. PATENT DOCUMENTS

D788,001 S	5/2017	Lee	D804,378 S	12/2017	Perkins
D788,641 S	6/2017	Arnold	D804,379 S	12/2017	McMahan
D788,644 S	6/2017	Mueller	D805,006 S	12/2017	Nakamura
D788,645 S	6/2017	Mueller	D805,013 S	12/2017	Whitla
D789,250 S	6/2017	Arnold	D805,014 S	12/2017	Zipfel
D789,260 S	6/2017	Smith	D805,441 S	12/2017	Karras
D789,575 S	6/2017	Willett	D805,964 S	12/2017	Whitla
D789,841 S	6/2017	Malczewski	D805,965 S	12/2017	Davis
D789,849 S	6/2017	Lee	D805,966 S	12/2017	Perkins
D791,018 S	7/2017	Mylenek	D805,985 S	12/2017	Nakamura
D791,644 S	7/2017	Fang	D807,232 S	1/2018	Bailie
D792,290 S	7/2017	Smith et al.	D807,239 S	1/2018	Perkins
D792,293 S	7/2017	McCabe et al.	D807,240 S	1/2018	Perkins
D792,294 S	7/2017	McCabe et al.	D807,241 S	1/2018	Perkins
D792,295 S	7/2017	McCabe et al.	D809,442 S	2/2018	Zipfel et al.
D792,815 S	7/2017	Kozub	D811,269 S	2/2018	Thompson et al.
D792,816 S	7/2017	Kozub	D811,942 S	3/2018	Jacob
D793,290 S	8/2017	Kozub	D811,957 S	3/2018	Whitla et al.
D793,292 S	8/2017	Lee	D811,958 S	3/2018	Zipfel et al.
D793,293 S	8/2017	Lee et al.	D811,959 S	3/2018	Perkins
D793,294 S	8/2017	Lee	D811,960 S	3/2018	Nakamura
D793,295 S	8/2017	McCabe et al.	D811,961 S	3/2018	Sullivan
D793,296 S	8/2017	Smith et al.	D811,962 S	3/2018	Sullivan
D793,297 S	8/2017	Smith et al.	D811,963 S	3/2018	Sullivan
D793,299 S	8/2017	Krieg et al.	D811,964 S	3/2018	Perkins
D793,300 S	8/2017	Krieg et al.	D811,965 S	3/2018	Moffett et al.
D793,301 S	8/2017	Kozub	D812,525 S	3/2018	Lee
D793,302 S	8/2017	Kozub	D812,526 S	3/2018	Zipfel et al.
D793,311 S	8/2017	Whitla et al.	D812,527 S	3/2018	Perkins
D793,590 S	8/2017	Kozub et al.	D812,528 S	3/2018	Nakamura
D793,591 S	8/2017	Kozub et al.	D813,098 S	3/2018	Thompson et al.
D793,917 S	* 8/2017	Kozub D12/163	D813,109 S	3/2018	Zipfel et al.
D793,918 S	8/2017	Kozub	D813,110 S	3/2018	Whitla et al.
D794,229 S	8/2017	Barry	D813,111 S	3/2018	Sullivan
D794,230 S	8/2017	Kozub	D813,116 S	3/2018	Park
D795,747 S	8/2017	Bailie	D813,117 S	3/2018	Sullivan
D795,757 S	8/2017	Pevovar et al.	D813,121 S	3/2018	Swanseger
D795,758 S	8/2017	Karras	D813,730 S	3/2018	Zipfel et al.
D795,759 S	8/2017	Kozub et al.	D813,731 S	3/2018	McMahan
D795,760 S	8/2017	Kozub et al.	D813,732 S	3/2018	Whitla et al.
D795,762 S	8/2017	Lee	D813,733 S	3/2018	Lee
D795,763 S	8/2017	Kozub	D813,734 S	3/2018	Nakamura
D796,088 S	8/2017	McCabe et al.	D813,740 S	3/2018	Park
D796,093 S	8/2017	Mainville	D813,741 S	3/2018	Perkins
D796,390 S	9/2017	Pevovar et al.	D813,742 S	3/2018	McMahan et al.
D797,537 S	9/2017	Cooper et al.	D813,743 S	3/2018	Lee
D797,603 S	9/2017	Noone et al.	D813,744 S	3/2018	Whitla et al.
D797,614 S	9/2017	Lee	D813,748 S	3/2018	Kim
D797,616 S	9/2017	Lee	D813,753 S	3/2018	Loeb
D797,624 S	9/2017	Nakamura	D813,754 S	3/2018	Loeb
D797,625 S	9/2017	Perkins	D813,755 S	3/2018	Loeb
D797,631 S	9/2017	Pevovar et al.	D813,756 S	3/2018	Loeb
D797,632 S	9/2017	Zipfel et al.	D813,757 S	3/2018	Kozub
D797,967 S	9/2017	Barry	D813,758 S	3/2018	Gonzales
D797,970 S	9/2017	Mainville	D813,759 S	3/2018	Perkins
D797,971 S	9/2017	Mainville	D814,369 S	4/2018	Loeb
D797,972 S	9/2017	Whitla et al.	D814,982 S	4/2018	Whitla et al.
D798,204 S	9/2017	Mainville	D814,983 S	4/2018	Whitla et al.
D799,384 S	10/2017	Kozub et al.	D815,570 S	4/2018	McMahan et al.
D799,385 S	10/2017	Kozub et al.	D815,572 S	4/2018	Perkins
D799,386 S	10/2017	Kozub et al.	D815,573 S	4/2018	Whitla et al.
D799,728 S	10/2017	Whitla et al.	D815,574 S	4/2018	Mainville
D801,236 S	10/2017	Kozub et al.	D815,993 S	4/2018	Kozub et al.
D801,577 S	10/2017	Ruiz	D815,994 S	4/2018	Nakamura
D801,882 S	11/2017	Kozub et al.	D816,003 S	4/2018	Perkins
D802,205 S	11/2017	Ruiz	D816,558 S	5/2018	McMahan et al.
D802,478 S	11/2017	Perkins	D816,559 S	5/2018	McMahan et al.
D802,491 S	11/2017	Mainville	D816,561 S	5/2018	McMahan
D802,496 S	11/2017	Mainville	D816,562 S	5/2018	Whitla et al.
D802,502 S	11/2017	McMahan	D816,563 S	5/2018	McMahan et al.
D803,727 S	11/2017	Noone et al.	D816,564 S	5/2018	Kim
D803,731 S	11/2017	Zipfel	D816,565 S	5/2018	Kim
D804,370 S	12/2017	Kozub et al.	D816,566 S	5/2018	Loeb
D804,371 S	12/2017	Whitla et al.	D817,836 S	5/2018	McMahan et al.
D804,372 S	12/2017	Kozub	D818,156 S	5/2018	Kim et al.
			D818,157 S	5/2018	Zipfel et al.
			D818,158 S	5/2018	Zipfel et al.
			D818,159 S	5/2018	Zipfel et al.
			D818,160 S	5/2018	Perkins

(56)

References Cited

U.S. PATENT DOCUMENTS

D818,406 S	5/2018	McMahan et al.	
D818,876 S	5/2018	Whitla et al.	
D818,877 S	5/2018	Nakamura et al.	
D818,878 S	5/2018	McMahan et al.	
D818,892 S	5/2018	Lee	
D818,893 S	5/2018	Kim	
D818,903 S	5/2018	Zipfel et al.	
D818,906 S	5/2018	McMahan	
D818,907 S	5/2018	Whitla et al.	
D818,915 S	5/2018	Kozub et al.	
D818,922 S	5/2018	Whitla et al.	
D819,505 S	6/2018	McMahan et al.	
D819,519 S	6/2018	Whitla et al.	
D830,918 S	* 10/2018	Kozub	D12/163

* cited by examiner

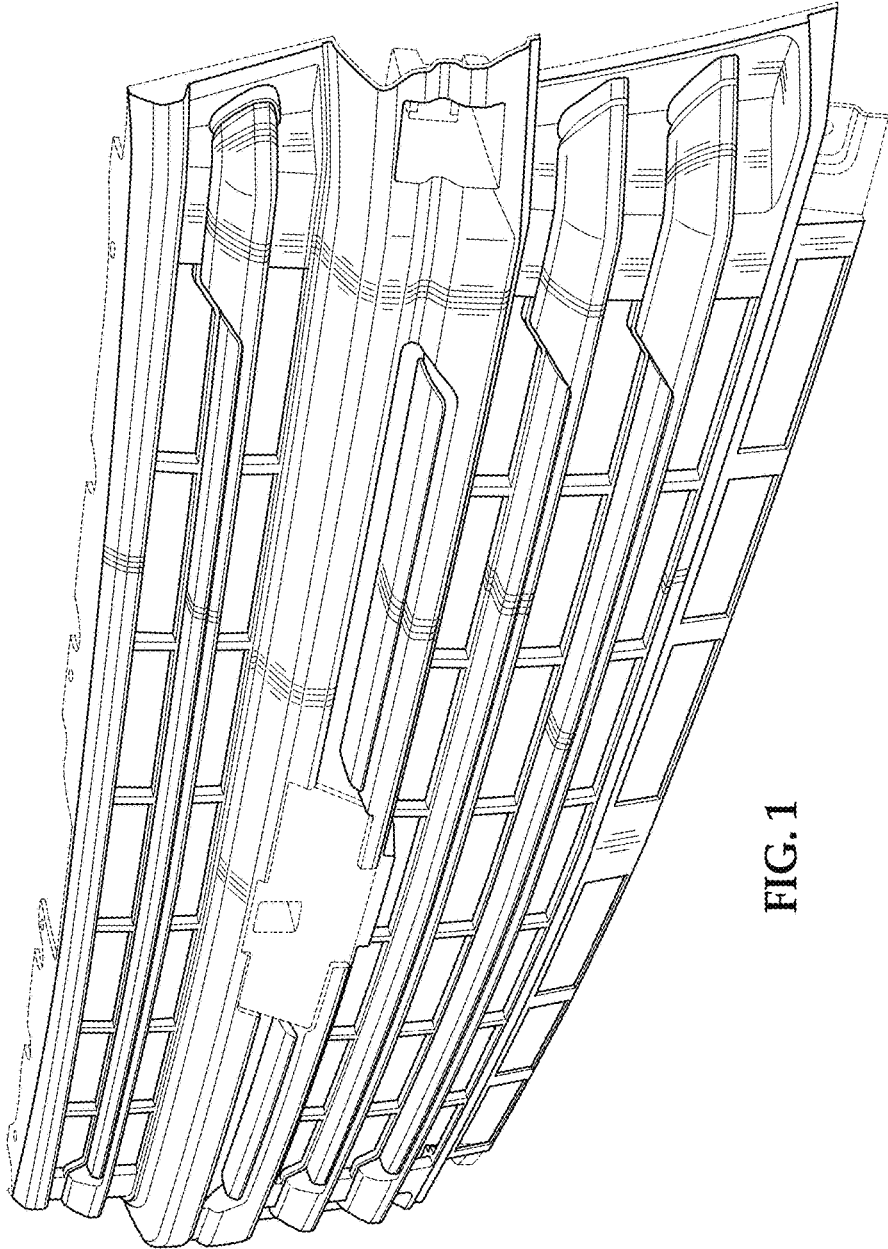

FIG. 1

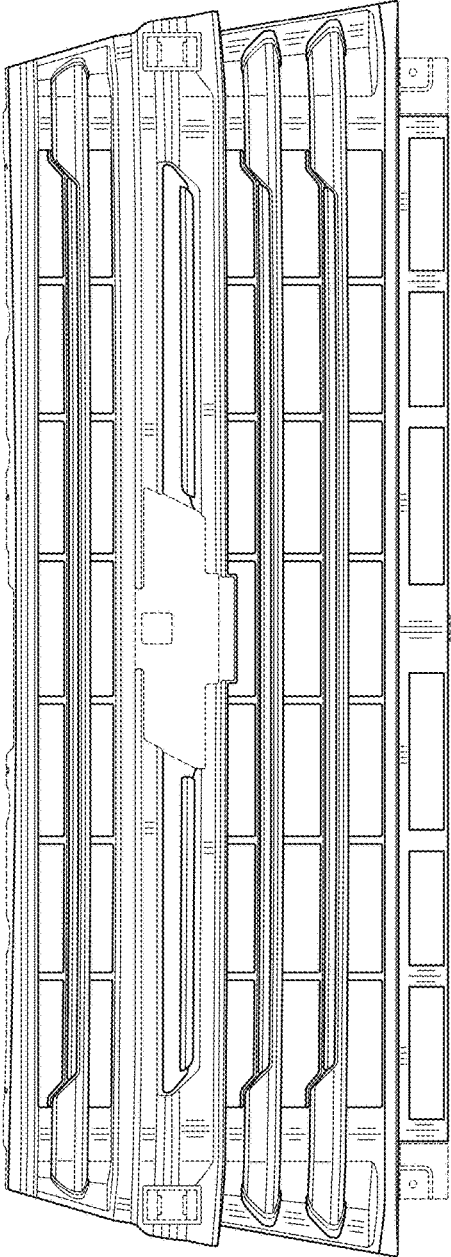

FIG. 2

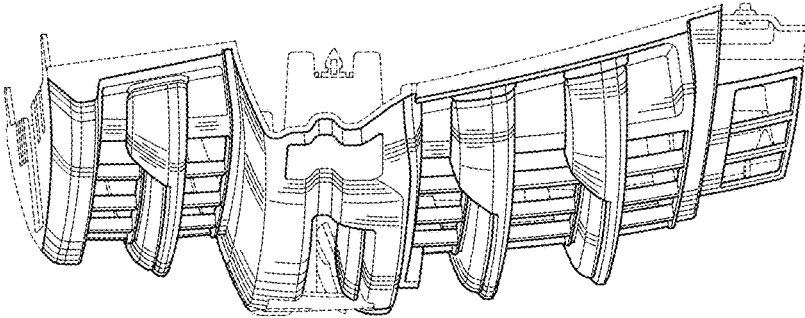

FIG. 3

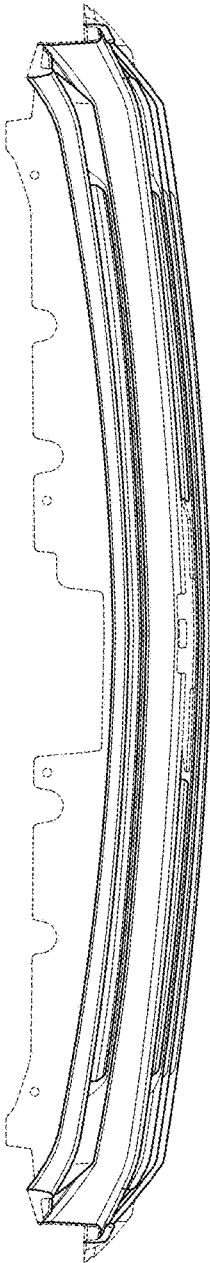

FIG. 4