

(19)



(11)

EP 2 709 495 B1

(12)

EUROPEAN PATENT SPECIFICATION

(45) Date of publication and mention of the grant of the patent:
07.11.2018 Bulletin 2018/45

(51) Int Cl.:
A47G 19/22 (2006.01) B65D 21/02 (2006.01)

(21) Application number: **12785980.9**

(86) International application number:
PCT/US2012/038380

(22) Date of filing: **17.05.2012**

(87) International publication number:
WO 2012/158937 (22.11.2012 Gazette 2012/47)

(54) BEVERAGE GLASS AND BEVERAGE GLASS ASSEMBLY

TRINKGLAS UND TRINKGLASANORDNUNG

VERRE POUR BOISSON ET ENSEMBLE VERRE POUR BOISSON

(84) Designated Contracting States:
AL AT BE BG CH CY CZ DE DK EE ES FI FR GB GR HR HU IE IS IT LI LT LU LV MC MK MT NL NO PL PT RO RS SE SI SK SM TR

(74) Representative: **Harris, Oliver John Richard et al**
Novagraaf UK
2nd Floor
Renown House
33-34 Bury Street
London EC3A 5AR (GB)

(30) Priority: **19.05.2011 US 201113111454**

(43) Date of publication of application:
26.03.2014 Bulletin 2014/13

(56) References cited:
WO-A1-2010/106239 DE-U1- 29 622 585
FR-A1- 2 554 786 US-A- 4 382 506
US-A- 4 679 699 US-A- 4 685 565
US-A1- 2003 221 987 US-A1- 2007 012 693
US-A1- 2008 083 639 US-A1- 2010 025 351
US-A1- 2010 176 022 US-A1- 2010 314 274

(73) Proprietor: **Stacked Wines, LLC**
Anaheim, CA 92801 (US)

(72) Inventor: **ZIMMER, Matt**
Newport Beach
CA 92663 (US)

EP 2 709 495 B1

Note: Within nine months of the publication of the mention of the grant of the European patent in the European Patent Bulletin, any person may give notice to the European Patent Office of opposition to that patent, in accordance with the Implementing Regulations. Notice of opposition shall not be deemed to have been filed until the opposition fee has been paid. (Art. 99(1) European Patent Convention).

Description

BACKGROUND

[0001] The present invention is directed to a beverage container such as a wine glass that can be sealed with a seal or lid that can be removed prior to consumption. The present invention also relates to assemblies of multiple beverage containers in a direct connected, attached configuration.

[0002] Beverages are commonly sold to consumers in containers such as glass or plastic bottles, aluminum or steel cans, cardboard or plastic cartons; or devices that include bladders containing the beverage. The beverage contained therein can be transferred to a suitable drinking glass composed of a suitable material including but not limited to glass, plastic, or the like for consumption. In certain situations, users prefer drinking beverages from individual serving containers such as cans, juice bottles and the like. However, many consumers prefer drinking certain types of beverages from glasses having wide mouths to enhance the aroma and, therefore, the flavor of the beverage.

DE 296 22 585 U1 discloses an assembly of containers connected together by screw threads to resemble a single, large bottle.

[0003] It would be desirable to provide individual servings of various beverages in sealed wide-mouth containers to enhance the aroma and taste of the beverage during consumption. It is also desirable to provide individual serving containers that can be positioned together into multi-serving container packages for sale or distribution.

SUMMARY

[0004] The present invention regards a beverage container assembly according to claim 1.

BRIEF DESCRIPTION OF THE DRAWINGS

[0005] The various features, advantages and other uses of the present apparatus will become more apparent by referring to the following detailed description and drawing in which:

FIG. 1 is a perspective view of an embodiment of the beverage container as disclosed herein;

FIG. 2 is a side view of an embodiment of the beverage container of FIG. 1;

FIG. 3 is a top view of the beverage container of FIG. 1;

FIG. 4 is a detail view of an embodiment of a rim elevation of the beverage container of FIG. 1;

FIG. 5 is a cross-sectional view taken along the 5-5 line of FIG. 3;

FIG. 6 is a detail view of an embodiment the rim portion of the beverage container of FIG. 1;

FIG. 7 is a bottom view of the beverage container of

FIG. 1;

FIG. 8 is a detail view of the bottom region of the beverage container of FIG. 1

FIG. 9 is detail view of the lip region of the beverage container of FIG. 1;

FIG. 10 schematically shows a second embodiment of a beverage container that engages another beverage container in accordance with the present invention;

FIG. 11 schematically shows a third embodiment of a beverage container that engages another beverage container in accordance with the present invention;

FIG. 12 schematically shows a perspective view of a fourth embodiment of a beverage container that engages another beverage container in accordance with the present invention;

FIG. 12a schematically shows a front, partial cross-sectional view of the beverage container engaging a second beverage container of FIG. 12;

FIG. 12b schematically shows a top cross-sectional view of the beverage container engaging a second beverage container of FIG. 12;

FIG. 13 is a perspective view an embodiment of a beverage container assembly as disclosed herein and in accordance with the present invention;

FIG. 14 is a front view of the beverage container assembly of FIG. 13;

FIG. 15 is a detail view of the junction between two of the beverage containers in the beverage container assembly of FIG. 13;

FIG. 16 is a perspective view an embodiment of a beverage container assembly system, wherein the beverage container assembly of FIG. 13 includes a removable cover in accordance with the present invention;

FIG. 17 is a front view of the beverage container assembly system of FIG. 16;

FIG. 18 is a top view of the beverage container assembly system of FIG. 16;

FIG. 19 is a top view of the beverage container assembly system of FIG. 16;

FIG. 20 is a side view of a beverage container as disclosed herein as an assembly with an embodiment of a removable beverage container accessory;

FIG. 21 is a detail view of the assembly of Fig 20;

FIG. 22 is a perspective view of the containers of FIGS. 10-15 altered to have connecting members and engagement members;

FIG. 23 is a top view of a first possible configuration of four beverage containers of FIGS. 1-15 using the connecting and engagement members of FIG. 22; and

FIG. 24 is a top view of a second possible configuration of four beverage containers of FIGS. 1-15 using the connecting and engagement members of FIG. 22.

DETAILED DESCRIPTION

[0006] As shown in the exemplary drawing figures, and referring particularly for FIG. 1, a beverage container 10 includes a beverage vessel body 12 and a removable lid 14 sealingly affixed to the beverage vessel body 12. The beverage vessel body 12 can be constructed of any suitable material. In various embodiments, the beverage vessel body 12 can be made of a suitable moldable polymeric material. Where desired or required, the material can be transparent. In specific embodiments, the material employed can be any material that is suitable for use with food stuffs. The material can be one that is dimensionally stable, but can provide minor deformation in specific applications. In applications where the beverage container 10 contains wine, the beverage vessel body 12 can be composed of a suitable transparent polymeric material. The lid 14 can be made of any suitable material including, but not limited to, foil, plastic and the like. The material employed in the lid 14 can be made of a material that is the same or different from the material of the vessel body 12. In some applications, it is contemplated that the material employed in the lid 14 will be more deformable than that employed in the vessel body 12 and will be able to conform to suitable dimensional contours by crimping or the like.

[0007] The beverage vessel body 12 includes a base 16 that has a circumference C_B as measured at the outer perimeter of a surface contacting region that has of a first defined value (see FIG. 7). The beverage vessel body 12 also has a side wall 20 that terminates at a rim 22. The side wall 20 and base 16 define an interior chamber of a specified volume. As such, the side wall 20 will have a suitable height H . The side wall 20 also has a side wall median M as shown in FIG. 2.

[0008] In the embodiments depicted in the drawing figures, the side wall 20 has a curvilinear outer contour that creates at least one outwardly protecting bulbous region 24 that extends beyond the perimeter created by the base 16. The side wall 20 has an inwardly tapering region 26 immediately above bulbous region 24 as shown in FIG. 2. Tapering region 26 terminates at rim 22, the geometry of which will be described in greater detail subsequently. In the embodiment depicted, the side wall 20 has bulbous region 24 located below the side wall height median M . Bulbous region 24 has a circumference C_W greater than the circumference C_B of base 16 as shown in FIG. 7. The side wall 20 curves upward from base 16 to the circumference maxima at C_W . The side wall 20 then enters a gentle inward curve that proceeds contiguously into tapering region 26. Circumference maxima at C_W can be any percentage greater than that of the circumference C_B of base 16. In certain embodiments, it is contemplated that the circumference maxima C_W can be between 10 and 50% greater than the circumference C_B of base 16.

[0009] The side wall 20 has an inwardly tapering region 26 between the bulbous region 24 and the rim 22. In the embodiment depicted, the rim 22 has a circumference

maxima C_R equal to or less than the circumference C_B of the base 16. In the embodiment depicted in the drawing figures, the outer circumference or circumference maxima C_R of the rim 22 will be between 0 and 15% less than the circumference C_B of base 16. In certain embodiments, the maximum circumference C_W of side wall 20 will be between 5% and 50% greater than the circumference C_B of base 16.

[0010] As shown in FIG. 2, side wall 20 can have a suitable inner face 28 opposed to a curvilinear outer face 30. In certain various embodiments, the inner and outer faces will be parallel. In the case of parallel inner and outer faces, the internal chamber defined in vessel body 12 will have greater volume in the regions below the median M .

[0011] The internal volume of the vessel body 12 contained in the internal chamber generally will be suitable to contain a suitable beverage serving. The vessel body 12 will be proportioned in a manner that provides the suitable volume. In certain embodiments, it is contemplated that the base 16 will have a cross-sectional diameter between 5.1 and 10.2 cm (2 and 4 inches). The outer diameter of rim 22 will be sufficient to permit releasable engagement between rim 22 of one container 10 and base 16 of a second container. The inner diameter of the rim 22 will be sufficient to permit the beverage to be consumed from the vessel body 12. The maximum diameter of side wall 20 in the bulbous region 24 can be between 0.6cm and 2.5cm (1/4 inch and 1 inch) greater than the diameter of base 16. The total height of the beverage container will be one that approximates the height of a 177ml (6 oz.) beverage glass in certain applications.

[0012] Rim 22 is contiguously joined to the upper region of side wall 20. As depicted in FIGS. 5-6, rim 22 includes a body 32 with a lip 34 projecting axially outward therefrom to a defined distance. In the embodiment depicted in the drawing figures, the lip 34 extends to provide an outer surface that can be received in a suitable orifice defined in the base 16 of a corresponding beverage vessel. In certain embodiments, the outer diameter of rim 22 is essentially equal to an inner diameter defined by base 16. The rim 22 also has an upwardly oriented surface that can include at least one upwardly oriented surface or bead 36 projecting therefrom.

[0013] Rim 22 is configured to be placed in mating contact with the lid 14 in a manner that facilitates establishment of a removed seal. Lid 14 can contact rim 22 in any suitable manner. In certain embodiments, the lid 14 is configured with a suitable edge region that is affixed to the rim 22 to maintain the beverage inside that vessel body 12. The lid 14 can be attached to the rim 22 in any suitable manner including, but not limited to, crimping adhesives and the like. Where an adhesive material is employed, the suitable adhesive material will be one that is suitable for use with food stuffs. The adhesive material can be present as a layer, bead, or other structure that is interposed between the rim 22 and the interior facing side of lid 14. Where desired or required, the interposed

adhesive can be positioned such that it contacts all or a portion of the upper surface of rim 22, such as bead 36.

[0014] The lid 14 can have any suitable configuration to sealingly engage the rim 14 and span the opening defined in the vessel body 12. In various embodiments, the lid 14 can be a thin planar member that can conform to and cover the defined opening. For example, the lid 14 can be made of a foil-like material that has a tab that extends beyond the bead so that a user can grasp the tab and remove the lid 14. When in sealing engagement, the lid 14 can deflect inward into the opening defined in the vessel body 12. The lid 14 can have a suitable peripheral region proximate to its outer edge that can be configured to conform to at least a portion of the rim 22.

[0015] The desired beverage can be sealed in the vessel body 12 by lid 14. The volume of beverage will be such that the height of the beverage comes to a suitable fill line F. When the vessel body is composed of a suitable transparent polymeric material, the beverage will be visible through the vessel body 12. Note that besides liquids, the vessel body 12 can contain other types of objects, such as solid foods.

[0016] The rim 22 can have any configuration that will facilitate sealing engagement between the lid 14 and the vessel body 12. In one configuration, the rim 22 can include a generally vertical neck portion with a bead present at an end thereof. In another embodiment shown in FIGS. 5-6, the rim 22 can be configured with a plurality of steps 40, 42 positioned on interiorly and exteriorly oriented surfaces relative to bead 36. It is contemplated that adhesives or other sealing material can be interposed between the interiorly oriented steps 40, 42 and lid 14. As used herein the term "adhere" is taken to include connection facilitated by direct rim-to-lid adhesion as well as interposition of a suitable adhesive layer between the rim 22 and the lid 14. Where a line of adhesive is used, it is contemplated that the adhesive line can be deployed so as to contact the bead 36 of rim 22 and, if desired, the adhesive can be disposed such that the adhesive contacts multiple planar surfaces defined in the inwardly oriented surface of the rim 22.

[0017] It is also within the purview of this disclosure to configure lid 14 to conform to one or more of the geometric ridges and/or shelves defined in the upper surface of the rim 22. Conformance can be accomplished during manufacture of lid 14 or during attachment of lid 14 to associated rim 22. Conformance fitting may be augmented by adhesives where desired or required.

[0018] In the embodiment depicted in FIG. 4-6, the rim 22 has at least one shoulder 38 radially interior of the bead 36. The shoulder 38 is has a maximum height or peak below bead 36. Shelf 40 is located radially interior to shoulder 38 and is positioned contiguous thereto. Shelf 40 terminates in a downwardly projecting upper portion of inner wall 28.

[0019] Where desired or required, the rim 22 can have suitable outer geometric details. In the embodiment depicted in Fig 4-6, the rim 22 has a shoulder 42 radially

outward of bead 36 and positioned below the bead 36. A shelf 44 is positioned radially outward of and below the shoulder 42 and is contiguously joined to it. The contours of the various shelves 40, 44 and shoulders 38, 42 will be sufficient to permit contact with lid 14, but will be small enough to permit an enjoyable drinking experience.

[0020] While an adhesive attachment between the lid 14 and the associated rim 22 has been previously described, other types of attachment are possible. For example, an outer edge of the lid 14 could be crimped like a beer bottle cap so as to engage an exterior side of the rim 22. Another possibility is to slightly melt the top layer of the rim 22 and/or the bottom of the lid 14 prior to placing the lid 14 thereon so that a seal is formed between the lid 14 and rim 22.]

[0021] The outer edge 46 of shelf 44 defines a downwardly extending wall region 48 that terminates in an inwardly curved lower region 50. In the embodiment depicted in FIGS. 5-6, the inwardly curved lower region 50 terminates in a cylindrical band portion 52 that is interposed between the rim 22 and the uppermost portion of side wall 20. Side wall 20 and cylindrical band portion 52 can be contiguous to one another or can have a suitable intermediate region 54 interposed between them. In the embodiment depicted in the various drawing figures, an inwardly tapered is interposed between the intermediate region 54 inwardly curved lower region 50 and the cylindrical band portion 52.

[0022] The vessel body 12 can also include a transitional region 55 interposed between band portion 52 and the upper region of side wall 20.

[0023] The base 16 of vessel body 12 can be configured to releasably engage with rim 22 of a similarly configured beverage vessel 10. In the embodiment depicted in FIGS. 8-9, the base 16 includes at least one arm member 56 having an outwardly oriented side 58 contiguously connected to the lower region of the side wall 20 at a location on vessel body 12 opposed to the rim 22. The arm member 56 defines an inwardly oriented detent 60 generally opposed to outwardly oriented side 58 that terminates in bottom wall (shown in phantom in FIGS. 8 and 9). The size, number and positioning of arm member(s) 56 is sufficient to releasably engage the rim 22 of a corresponding beverage container 10. As depicted in FIGS. 7, 8 and 9, the device has one arm member 56 that extends continuously around the circumference of the base 16 and defines a surface contacting region 64.

[0024] The detent 60 can have any suitable internal wall configuration sufficient to receive and maintain at least a portion of rim 22 of an associated beverage device 10 in engaged relationship. In the embodiment depicted, the internal wall of detent 60 has a concave configuration that can releasably engage the corresponding rim 22. In the embodiment depicted, the inner wall of detent 60 contacts the shoulder 50 associated with rim 22.

[0025] The arm member 56 can be either of solid or hollow construction depending on the specific application. In the embodiment depicted in the drawing figures,

arm member 56 is a continuous solid circular body contiguously positioned relative to side wall 20 and bottom surface 62. Without being bound to any theory, it is believed that the solid continuous arm member 56 provides stability to the associated vessel body 12. It is further believed that solid continuous arm member 56, when employed with solid rim 22 as further associated with curve linear side wall 20 provides a structurally robust beverage container 10.

[0026] The bottom surface 62 (shown in phantom in FIGS. 2, 8 and 9) can have any suitable geometric configuration. In the embodiment set forth in the drawing figures, the bottom surface 62 has an inwardly curved geometry having a lowest region proximate to arm member 56 and a maximum inwardly oriented point proximate to the radial center of the device 10. The arc defined by curved bottom surface 62 is between 1 degree and 30 degrees from planar.

[0027] Engagement between rim 22 and the arm member 56 generally occurs at a junction point located at a lower portion of detent 60 and rounded shoulder region 50 of the respective elements.

[0028] Note that other connections between a base 16 of one beverage container 10 and a rim 22' of another beverage container 10' are possible. For example, an interior side surface of the base 16 of one beverage container 10 of FIGS. 1-9 can be altered to have a threaded pattern 80 that is threadedly engaged by a threaded pattern 82 formed on an exterior surface of the rim 22' of another beverage container 10' as shown in FIG. 10. Thus, the beverage containers 10 and 10' are screwed onto one another. Of course, the attachment scheme can be reversed where the threaded pattern 80 is formed on an exterior surface of the base 16 and the threaded pattern 82 is formed on an interior surface of the rim 22', the base 16 dimensioned so that the threaded patterns can engage one another. So, in summary, the bases and rims of each of the beverage containers 10, 10' of FIGS. 1-9 can be altered to include the threaded engagement disclosed above.

[0029] Another possible attachment scenario is shown in FIG. 11. In particular, the base 16 of FIGS. 1-9 is altered so an interior surface 84 of a lower portion of the side wall 20 defines a vertical surface. A bottom surface 62 is formed above the bottom edge 86 of the interior surface. As shown in FIG. 11, a channel 88 is formed in the interior surface 84, wherein one end 90 of the channel 88 is formed at the bottom edge 86 so that access to the channel 88 at the bottom edge 86 is possible. The channel 88 rises at an angle from the bottom edge 86 and then levels off at another end 92. Before leveling off, the channel 88 includes a protrusion 94. The channel 88 and protrusion 94 are dimensioned and structured so that when a nub 96 formed on the rim 22 of another container moves along the channel 88, the nub 96 is trapped in end 92 after the nub 96 passes the protrusion 94.

[0030] With the above structure in mind, attachment of the rim 22 of one container to the base 16 of another

container is accomplished by inserting the rim 22 of one container within the interior surface 84 of another container. Next, the two containers are rotated relative to one another in a first direction until a nub 96 on the rim 22 of one container is inserted into the channel 88 of the other container and passes the protrusion 94. The containers are effectively locked to one another until relative rotation between the two containers is performed in a direction opposite to the first direction. If sufficient torque is applied, the nub 96 will pass the protrusion 94 and be fed to the bottom edge of the container where the rim 22 can be released.

[0031] Another possible attachment scenario is shown in FIGS. 12a-b. In particular, the base 16 of FIGS. 1-9 is altered so that lower portion at the bottom edge extends approximately 180° so as to be C-shaped. So, in practice, the lid 22' of one container is slid into the detent 60 until the rim 22' reaches the rear portion 98 of the base 16. The rim 22' and the base 16 are locked to one another by using a channel and nub system similar to that described with respect to FIG. 11. The structure of the channel formed in the interior of the side wall where the detent 60 is present is basically the same as that described with respect to the channel 88 of FIG. 11. One difference is that unlike protrusion 94 of FIG. 11, the protrusion is formed in the side of the channel 88 and not the bottom as shown in FIG. 11. With the above described channel described, locking between the rim 22' and the base 16 is accomplished by sliding the rim 22' into the detent 60 and then twisting the rim 22' and base 16 relative to one another until a nub formed in the rim 22' slides into the channel and rises up the channel until it moves over the protrusion into an end portion of the channel where the rim 22' and base 16 are locked. Twisting in the opposite direction with sufficient torque will release the nub from the channel in the manner similar to that described previously with respect to FIG. 11.

[0032] The present disclosure contemplates an assembly of beverage containers such as those previously described the assembly including at least two beverage containers each having a vessel body 12 and a lid 14. An example of such an assembly when the beverage containers of FIGS. 1-9 are used is shown in FIGS. 13-15. Each beverage container 10 has a serving of a given beverage located in a sealed chamber defined in the vessel body 12. The serving size can be a predetermined amount. In applications where the beverage container 10 is configured to contain wine, the serving size can be between 2 oz. and 6 oz. by way of example. In the assembly 200, as depicted in FIGS. 14 and 15, the base 16 of at least one first beverage container 10 releasably engages the rim 22' of a second beverage container 10' such that a lid 14' of the second beverage container 10' is interposed between the respective rim 22' and base 16. In addition, note that the beverage container at the top of the stack may include a plastic cap to cover the lid.

[0033] The assembly 200 can be composed of any number of beverage containers 10, 10'. Certain assem-

bles can be composed of even multiples of beverage containers with assemblies of two and four being typical in certain applications. The assembly 200 of FIGS. 13-15 can further include an outer covering member. Non-limiting examples of outer covering include boxes and shrink wrap and the like.

[0034] An example of a possible outer covering is shown in FIGS. 16-19. The outer covering 300 is made of a flexible, plastic material, such as PET, that has an opening at both ends thereof. The assembly 200 of FIGS. 13-15 is inserted bottom end first through the opening so that the covering 300 and assembly 200 define a covered assembly of beverage containers 302. In the case of using PET for covering 300, the covering 300 and assembly combination are placed in a steam tunnel or the like, which results in the covering shrinking and taking on the shape of the assembly of beverage containers. As shown in FIGS. 16-17, the material takes on the exterior shape of the assembly 200 along the sides. At the top, an annular ring may be formed around the outer edge of the plastic cap attached to the lid 14 and rim 22. At the bottom, an annular portion 306 is centered about the center of the base 16. Note that the covering 300 may contain various features. For example, the covering 300 may include an opening 308 so that an observer can determine the contents within the covering 300. The covering 300 may include an opening device 310 that includes an area that extends along the length of the assembly 302 and the area is so weakened that when a user pulls on a tab area 308 at the top and along the length of the opening device the area breaks apart to reveal the beverage containers therein. As shown in FIGS. 16-17, the area includes two parallel lines of holes, wherein each hole 312 is approximately 1 mm in diameter and there are about 7 holes per every centimeter along the length of the area. The lines of holes are separated from one another by approximately 8 mm. When the tab area 308 is pulled downward, the material along one of the lines of holes and between the holes of that line is broken apart. The same process occurs with the other line of holes so that a slit-like opening is formed between the lines of holes.

[0035] The beverage containers 10, 10' etc. can be dimensioned to approximate the height and maximum width dimensions of a standard wine bottle. Thus an assembly 200 of four beverage containers 10, 10', 10", 10''' positioned in stacked end-to-end relationship will have the approximate height of a standard wine bottle. The assembly can contain four servings of the same or different wines. Each container can be accessed by removing the respective lid. The contents can be consumed from the opened beverage container which can be used as a drinking glass.

[0036] While the present disclosure has presented engagement between two beverage containers 10, it is also considered within the purview of the present disclosure to provide releasable engagement between a beverage container 10 and a suitable accessory. One non-limiting example of a suitable accessory to be engaged by the

beverage container 10 of FIGS. 1-9 is wine glass support 100 depicted in FIGS. 20 and 21. Wine glass support 100 includes a suitable head 110, base 112 and stem 114 interposed between head 110 and base 112. Head 110 is configured to releasably engage a suitably configured base 16 of beverage container 10. In the embodiment depicted, head 110 of wine glass support 100 includes a suitable rim 122 configured to matingly contact arm member(s) 56. In the embodiment illustrated, rim 122 is matingly received in the orifice defined by continuous circular arm member 56 in the manner described previously. Other accessories are contemplated, including but not limited to Pilsner stems as well as plate members and the like.

[0037] When the beverage container 10 is employed with an accessory such as wine glass support 100, the support 100 can be attached when desired. Typically the support 100 will be attached to base 16 of beverage container 10 prior to removal of lid 14.

[0038] As previously described with respect to the beverage containers 10 and system 200 of FIGS. 1-15, attachment between the lids/rims of one container with the base of another container are possible. Further attachments are possible. As shown in FIG. 22, it is contemplated that the container 10 of FIGS. 1-15 are adapted to include one or more connecting members 402 on the side wall 20. Such connecting members 402 are adapted to engage with engagement members 404 of another container 10'. For example, it is contemplated that connecting member 402 would be a male member of a snap and attachment member 404 would be a corresponding female member of the snap. Of course other engagement structures for members 402 and 404 are possible.

[0039] Note that the above described side engagement allows for a variety of packaging configurations, one of which is shown in FIG. 23. Another pattern would be to connect each container 10 side-to-side along a line using members 402 and 404 as shown in FIG. 24. If one of the unattached sides had a sufficient shape, such as a flat surface, the entire line of attached containers could be rotated so that the previously mentioned unattached side was placed on a surface so that the line of containers extended vertically from that surface so as to define a stack similar to those shown in FIGS. 13 and 14.

Claims

1. An assembly (200) comprising:

a first beverage container (10) comprising:

a first vessel body (12), the first vessel body comprising:

a first base (16) having a first perimeter;
a first side wall (20) connected to the first base; and

a first rim (22) defined on the first side wall distal to the first base, the first side wall comprising a side wall median (M) and a central section having a maximum circumference (C_V) greater than a circumference (C_B) of the first base, the maximum circumference located at a position on the first side wall between the side wall median and the first base; and

a first lid (14) having a first seal region, the first seal region removably attached to an upper surface of the first rim;
 a first material that adheres to the first seal region and the first rim so that the first seal region is removably attached to the first rim; and

a second beverage container (10) comprising:

a second vessel body (12) comprising:

a second base (16) having a second perimeter;
 a second side wall (20) connected to the second base; and
 a second rim (22) defined on the second side wall distal to the second base, wherein the first rim is releasably attached to the second base of the second beverage container such that the first lid of the first beverage container is interposed between the first rim of the first beverage container and the second base of the second beverage container; and

a second lid (14) having a second seal region, the second seal region removably attached to the second rim; and
 a second material that adheres to the second seal region and the second rim so that the second seal region is removably attached to the second rim.

2. The assembly of claim 1, wherein the first rim comprises a threaded pattern (82) that engages a threaded pattern (80) formed on the second base.
3. The assembly of claim 1 wherein the second base comprises a channel (88) that slidably receives a male element (96) formed on the first rim.
4. The assembly of claim 3, wherein the male element is locked in position within the channel.
5. The assembly of claim 3, wherein the channel com-

prises a protrusion (94), such that when the male element passes the protrusion the male element is locked in position within the channel.

- 5 6. The assembly of claim 1 wherein the second lid is slidably received in a channel formed in the first base.
7. The assembly of claim 6, wherein the second lid is locked in position within the channel.
8. The assembly of claim 1, further comprising a cover (300) that encloses the first beverage container and the second beverage container.
9. The assembly of claim 1 wherein the second base of the second beverage container comprises a bottom surface (62) and an arm member (56) extending downward from the second side wall, the arm member comprising:
 - an inwardly oriented side;
 - an outwardly oriented side (58);
 - a surface contacting region (64); and
 - a detent region (60) defined on the inwardly oriented side.
10. The assembly of claim 9 wherein the first rim comprises a plurality of ridge members oriented on the first rim in spaced annular parallel relationship to one another.
11. The assembly of claim 10 further comprising a covering member (300).
12. The assembly of claim 11 wherein the covering member is selected from the group consisting of shrink wrap and a box.
13. The assembly of claim 10, wherein:
 - (a) the second base comprises an inwardly concave surface (62) and the detent region (60) is located between the surface contacting region (64) and the bottom surface (62);
 - (b) the second side wall has a cylindrical portion and the arm member extends around a lower periphery of the second side wall;
 - (c) the first lid has a region configured to sealably conform to at least one of the plurality of ridge members; or
 - (d) the second rim comprises a plurality of ridge members oriented on the second rim in spaced annular parallel relationship to one another.
14. The assembly of claim 1, wherein a liquid is present within:

- (a). an interior of the first vessel body, wherein when the first lid is completely sealed to the first rim the liquid directly contacts the first vessel body; or
 (b). an interior of the second vessel body, wherein when the second lid is completely sealed to the second rim the liquid directly contacts the second vessel body. 5
15. The assembly of claim 9, wherein: 10
- (a). the first rim releasably engages a portion of the detent region (60); or
 (b). releasable attachment between the first rim and the portion of the detent region (60) is accomplished by the first rim contacting the portion of the detent region. 15
16. An assembly according to claim 1, wherein the first rim (22) of the first beverage container (10) has a maximum circumference (C_R) between 0% and 15% less than the circumference (C_B) of the first base (16), and the maximum circumference (C_W) of the central section of the first side wall (20) is between 5% and 50% greater than the circumference (C_B) of the first base (16), and the first rim (22) of the first beverage container is configured to permit a beverage to be consumed from the first vessel body (12). 20 25 30

Patentansprüche

1. Baugruppe (200), die Folgendes umfasst: 35
- einen ersten Getränkecontainer (10), der Folgendes umfasst:
- einen ersten Gefäßkörper (12), wobei der erste Gefäßkörper Folgendes umfasst: 40
- eine erste Basis (16) mit einem ersten Perimeter;
 eine erste Seitenwand (20), die mit der ersten Basis verbunden ist; und
 einen ersten Rand (22), der an der ersten Seitenwand distal von der ersten Basis definiert ist, wobei die erste Seitenwand ein Seitenwandmedian (5) und eine zentrale Sektion mit einem maximalen Umfang (C_W) umfasst, der größer ist als ein Umfang (C_B) der ersten Basis, wobei sich der maximale Umfang an einer Position an der ersten Seitenwand zwischen dem Seitenwandmedian und der ersten Basis befindet; und 45 50 55
- einen ersten Deckel (14) mit einer ersten Verschlussregion, wobei die erste Verschlussregion entfernbar an einer Oberseite des ersten Randes angebracht ist; ein erstes Material, das an der ersten Verschlussregion und dem ersten Rand haftet, so dass die erste Verschlussregion entfernbar am ersten Rand angebracht ist; und
- einen zweiten Getränkecontainer (10), der Folgendes umfasst:
- einen zweiten Gefäßkörper (12), der Folgendes umfasst:
- eine zweite Basis (16) mit einem zweiten Perimeter;
 eine zweite Seitenwand (20), die mit der zweiten Basis verbunden ist; und
 einen zweiten Rand (22), der an der zweiten Seitenwand distal von der zweiten Basis definiert ist, wobei der erste Rand lösbar an der zweiten Basis des zweiten Getränkecontainers angebracht ist, so dass sich der erste Deckel des ersten Getränkecontainers zwischen dem ersten Rand des ersten Getränkecontainers und der zweiten Basis des zweiten Getränkecontainers befindet; und
- einen zweiten Deckel (14) mit einer zweiten Verschlussregion, wobei die zweite Verschlussregion entfernbar am zweiten Rand angebracht ist; und
 ein zweites Material, das an der zweiten Verschlussregion und dem zweiten Rand haftet, so dass die zweite Verschlussregion entfernbar am zweiten Rand angebracht ist.
2. Baugruppe nach Anspruch 1, wobei der erste Rand ein Gewindemuster (82) aufweist, das in ein an der zweiten Basis ausgebildetes Gewindemuster (80) eingreift.
3. Baugruppe nach Anspruch 1, wobei die zweite Basis einen Kanal (88) aufweist, der ein am ersten Rand ausgebildetes Steckelement (26) gleitfähig aufnimmt.
4. Baugruppe nach Anspruch 3, wobei das Steckelement in dem Kanal in seiner Position arretiert wird.
5. Baugruppe nach Anspruch 3, wobei der Kanal einen Vorsprung (94) aufweist, so dass das Steckelement, wenn es den Vorsprung passiert, in seiner Position im Kanal arretiert wird.

6. Baugruppe nach Anspruch 1, wobei der zweite Deckel in einem in der ersten Basis ausgebildeten Kanal gleitfähig aufgenommen wird.
7. Baugruppe nach Anspruch 6, wobei der zweite Deckel in seiner Position im Kanal arretiert wird. 5
8. Baugruppe nach Anspruch 1, die ferner eine Abdeckung (300) umfasst, die den ersten Getränkecontainer und den zweiten Getränkecontainer umschließt. 10
9. Baugruppe nach Anspruch 1, wobei die zweite Basis des zweiten Getränkecontainers eine Bodenfläche (62) und ein sich von der zweiten Seitenwand nach unten erstreckendes Armelement (56) umfasst, wobei das Armelement Folgendes umfasst:
- eine nach innen orientierte Seite;
eine nach außen orientierte Seite (58); 20
eine Oberflächenkontaktregion (64); und
eine Rastregion (60), die in der nach innen orientierten Seite definiert ist.
10. Baugruppe nach Anspruch 9, wobei der erste Rand eine Mehrzahl von Rippelementen umfasst, die am ersten Rand in einer beabstandeten ringförmigen parallelen Beziehung zueinander orientiert sind. 25
11. Baugruppe nach Anspruch 10, die ferner ein Abdeckelement (300) umfasst. 30
12. Baugruppe nach Anspruch 11, wobei das Abdeckelement ausgewählt ist aus der Gruppe bestehend aus einer Schrumpffolienverpackung und einer Box. 35
13. Baugruppe nach Anspruch 10, wobei:
- (a) die zweite Basis eine nach innen konkave Oberfläche (62) umfasst und die Rastregion (60) sich zwischen der Oberflächenkontaktregion (64) und der Bodenfläche (62) befindet; 40
(b) die zweite Seitenwand einen zylindrischen Abschnitt hat und das Armelement um eine untere Peripherie der zweiten Seitenwand herum verläuft; 45
(c) der erste Deckel eine Region hat, konfiguriert zum verschließenden Anpassen an die Form von wenigstens einem aus der Mehrzahl von Gratelementen; oder 50
(d) der zweite Rand eine Mehrzahl von Gratelementen umfasst, orientiert am zweiten Rand in einer beabstandeten ringförmigen parallelen Beziehung zueinander. 55
14. Baugruppe nach Anspruch 1, wobei eine Flüssigkeit vorhanden ist in:

- (a) einem Innern des ersten Gefäßkörpers, wobei die Flüssigkeit, wenn der erste Deckel auf dem zweiten Rand vollständig verschließt, direkt mit dem ersten Gefäßkörper in Kontakt kommt; oder
(b) einem Inneren des zweiten Gefäßkörpers, wobei die Flüssigkeit, wenn der zweite Deckel auf dem zweiten Rand vollständig verschließt, direkt mit dem zweiten Gefäßkörper in Kontakt kommt.

15. Baugruppe nach Anspruch 9, wobei:

- (a) der erste Rand lösbar in einen Abschnitt der Rastregion (60) eingreift; oder
(b) ein lösbares Anbringen zwischen dem ersten Rand und dem Abschnitt der Rastregion (60) dadurch erzielt wird, dass der erste Rand mit dem Abschnitt der Rastregion in Kontakt kommt.

16. Baugruppe nach Anspruch 1, wobei der erste Rand (22) des ersten Getränkecontainers (10) einen maximalen Umfang (C_R) zwischen 0 % und 15 % kleiner als der Umfang (C_B) der ersten Basis (16) hat, und der maximale Umfang (C_W) der zentralen Sektion der ersten Seitenwand (20) zwischen 5 % und 50 % größer ist als der Umfang (C_B) der ersten Basis (16), und der erste Rand (22) des ersten Getränkecontainers so konfiguriert ist, dass er es zulässt, dass ein Getränk aus dem ersten Gefäßkörper (12) konsumiert wird.

Revendications

1. Ensemble (200) comportant :

un premier contenant pour boisson (10) comportant :

un premier corps de récipient (12), le premier corps de récipient comportant :

une première base (16) ayant un premier périmètre ;
une première paroi latérale (20) reliée à la première base ; et
un premier rebord (22) défini sur la première paroi latérale de manière distale par rapport à la première base, la première paroi latérale comportant une partie médiane de paroi latérale (M) et une section centrale ayant une circonférence maximum (C_W) supérieure par rapport à une circonférence (C_B) de la première base, la circonférence maxi-

mum étant située au niveau d'une position sur la première paroi latérale entre la partie médiane de paroi latérale et la première base ; et

un premier couvercle (14) ayant une première région d'étanchéité, la première région d'étanchéité étant attachée de manière amovible à une surface supérieure du premier rebord ;

un premier matériau qui vient s'adhérer à la première région d'étanchéité et au premier rebord de telle sorte que la première région d'étanchéité est attachée de manière amovible au premier rebord ; et

un deuxième contenant pour boisson (10) comportant :

un deuxième corps de récipient (12) comportant :

une deuxième base (16) ayant un deuxième périmètre ;

une deuxième paroi latérale (20) reliée à la deuxième base ; et

un deuxième rebord (22) défini sur la deuxième paroi latérale de manière distale par rapport à la deuxième base, dans lequel le premier rebord est attaché de manière amovible à la deuxième base du deuxième contenant pour boisson de telle sorte que le premier couvercle du premier contenant pour boisson est intercalé entre le premier rebord du premier contenant pour boisson et la deuxième base du deuxième contenant pour boisson ; et

un deuxième couvercle (14) ayant une deuxième région d'étanchéité, la deuxième région d'étanchéité étant attachée de manière amovible au deuxième rebord ; et

un deuxième matériau qui vient s'adhérer à la deuxième région d'étanchéité et au deuxième rebord de telle sorte que la deuxième région d'étanchéité est attachée de manière amovible au deuxième rebord.

2. Ensemble selon la revendication 1, dans lequel le premier rebord comporte un motif fileté (82) qui entre en prise avec un motif fileté (80) formé sur la deuxième base.
3. Ensemble selon la revendication 1, dans lequel la deuxième base comporte un profilé en U (88) qui reçoit de manière coulissante un élément mâle (96) formé sur le premier rebord.

4. Ensemble selon la revendication 3, dans lequel l'élément mâle est verrouillé en place à l'intérieur du profilé en U.

5. Ensemble selon la revendication 3, dans lequel le profilé en U comporte une partie saillante (94), de telle sorte que, quand l'élément mâle passe par la partie saillante, l'élément mâle est verrouillé en place à l'intérieur du profilé en U.

6. Ensemble selon la revendication 1, dans lequel le deuxième couvercle est reçu de manière coulissante dans un profilé en U formé dans la première base.

7. Ensemble selon la revendication 6, dans lequel le deuxième couvercle est verrouillé en place à l'intérieur du profilé en U.

8. Ensemble selon la revendication 1, comportant par ailleurs une enveloppe (300) qui renferme le premier contenant pour boisson et le deuxième contenant pour boisson.

9. Ensemble selon la revendication 1, dans lequel la deuxième base du deuxième contenant pour boisson comporte une surface inférieure (62) et un élément formant patte (56) s'étendant vers le bas depuis la deuxième paroi latérale, l'élément formant patte comportant :

un côté orienté vers l'intérieur ;
un côté orienté vers l'extérieur (58) ;
une région en contact avec la surface (64) ; et
une région de détente (60) définie sur le côté orienté vers l'intérieur.

10. Ensemble selon la revendication 9, dans lequel le premier rebord comporte une pluralité d'éléments formant nervure orientés sur le premier rebord selon une relation parallèle annulaire espacée les uns par rapport aux autres.

11. Ensemble selon la revendication 10, comportant par ailleurs un élément formant enveloppe (300).

12. Ensemble selon la revendication 11, dans lequel l'élément formant enveloppe est sélectionné dans le groupe constitué par un film thermorétractable et une boîte.

13. Ensemble selon la revendication 10, dans lequel :

(a) la deuxième base comporte une surface concave vers l'intérieur (62) et la région de détente (60) est située entre la région en contact avec la surface (64) et la surface inférieure (62) ;
(b) la deuxième paroi latérale a une partie cylindrique et l'élément formant patte s'étend

autour d'une périphérie inférieure de la deuxième paroi latérale ;

(c). le premier couvercle a une région configurée pour être conforme de manière étanche à au moins l'un de la pluralité d'éléments formant nervure ; ou

(d). le deuxième rebord comporte une pluralité d'éléments formant nervure orientés sur le deuxième rebord selon une relation parallèle annulaire espacée les uns par rapport aux autres.

14. Ensemble selon la revendication 1, dans lequel un liquide est présent dans :

(a). une partie intérieure du premier corps de récipient, dans laquelle, quand le premier couvercle est entièrement scellé sur le premier rebord, le liquide entre directement en contact avec le premier corps de récipient ; ou

(b). une partie intérieure du deuxième corps de récipient, dans laquelle, quand le deuxième couvercle est entièrement scellé sur le deuxième rebord, le liquide entre directement en contact avec le deuxième corps de récipient.

15. Ensemble selon la revendication 9, dans lequel :

(a). le premier rebord entre en prise de manière amovible avec une partie de la région de détente (60) ; ou

(b). l'attachement amovible entre le premier rebord et la partie de la région de détente (60) est accompli par le premier rebord entrant en contact avec la partie de la région de détente.

16. Ensemble selon la revendication 1, dans lequel le premier rebord (22) du premier contenant pour boisson (10) a une circonférence maximum (C_R) entre 0 % et 15 % inférieure par rapport à la circonférence (C_B) de la première base (16), et la circonférence maximum (C_W) de la section centrale de la première paroi latérale (20) est entre 5 % et 50 % supérieure par rapport à la circonférence (C_B) de la première base (16), et le premier rebord (22) du premier contenant pour boisson est configuré pour permettre à une boisson d'être consommée en provenance du premier corps de récipient (12).

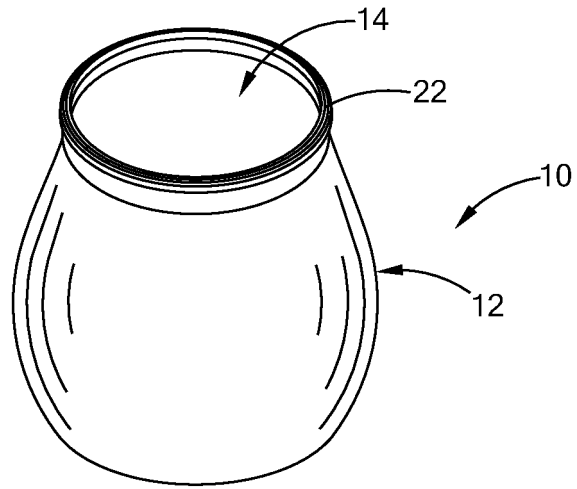

FIG. 1

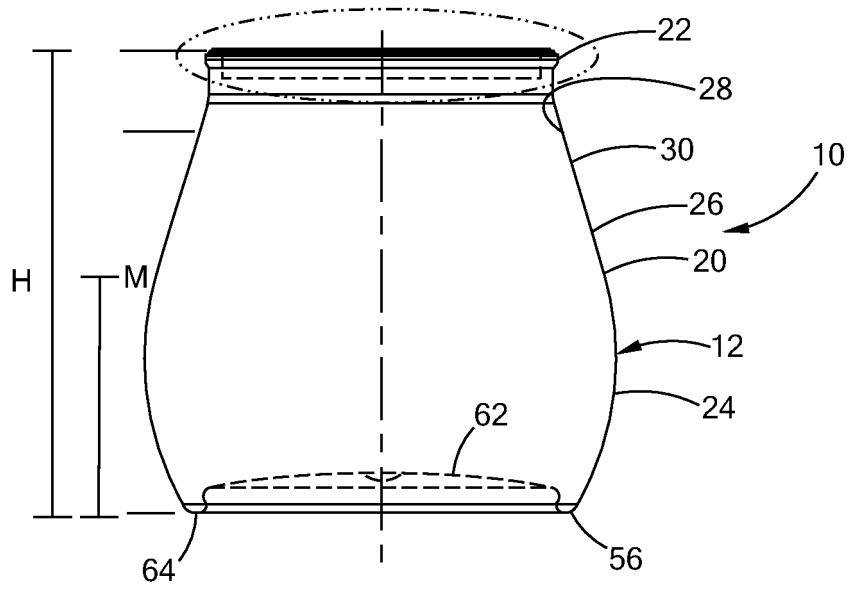

FIG. 2

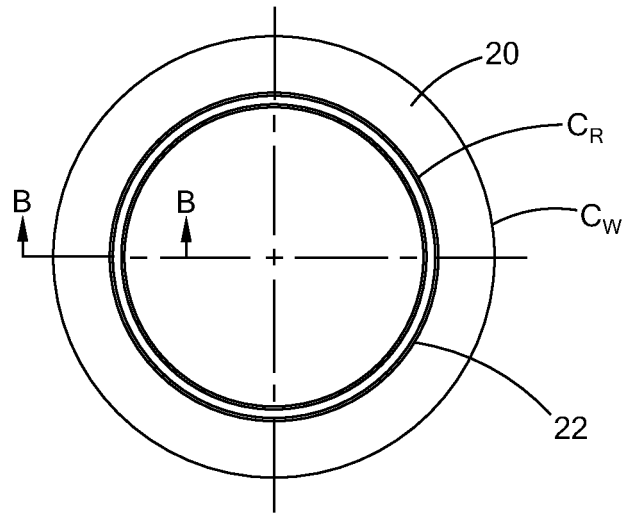

FIG. 3

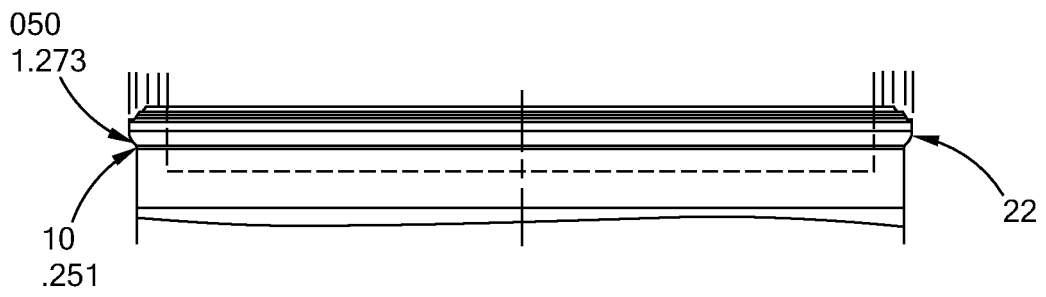

FIG. 4

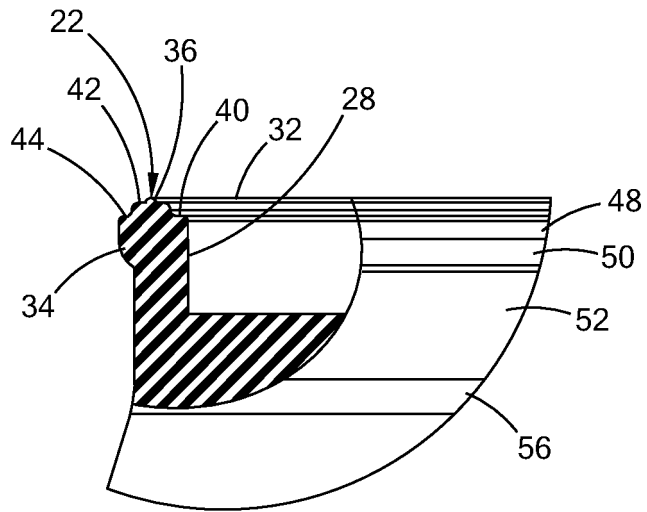

FIG. 5

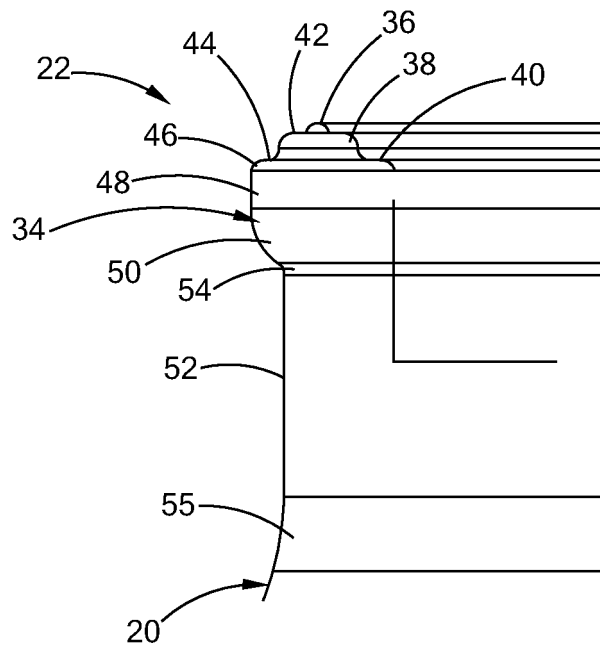

FIG. 6

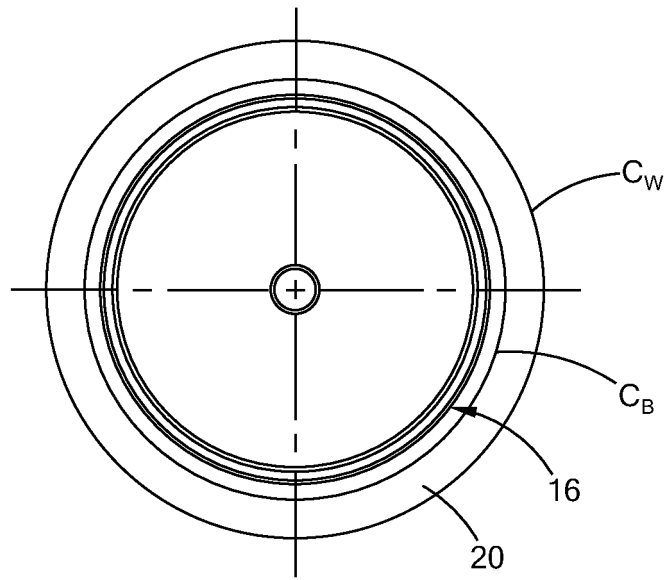

FIG. 7

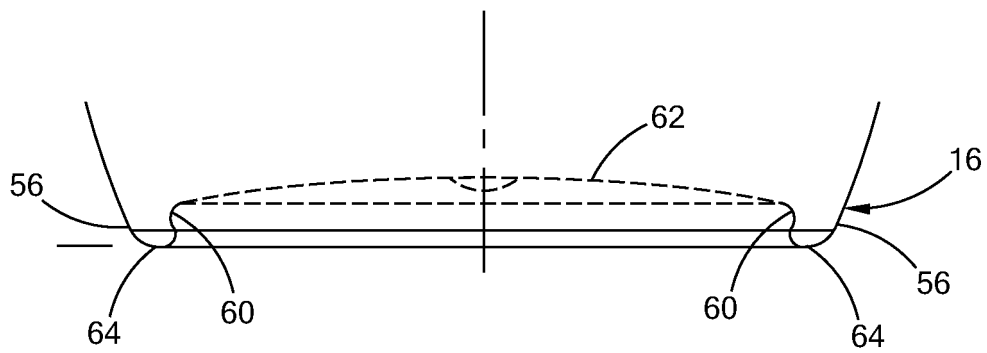

FIG. 8

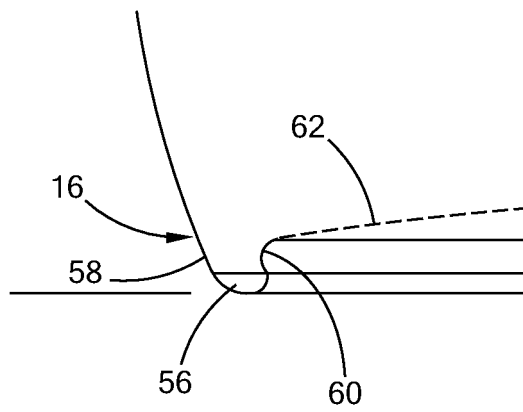

FIG. 9

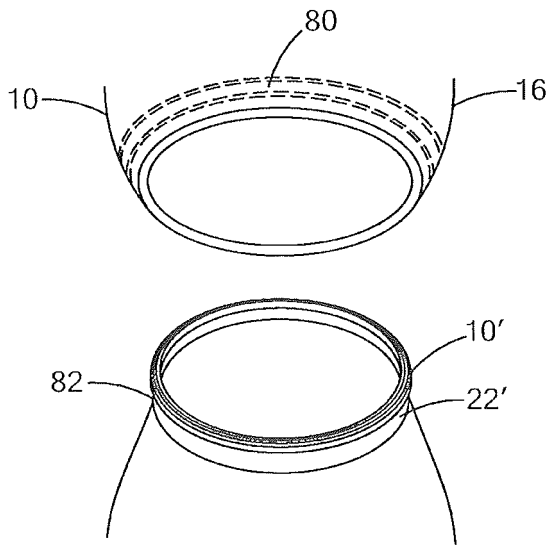

FIG. 10

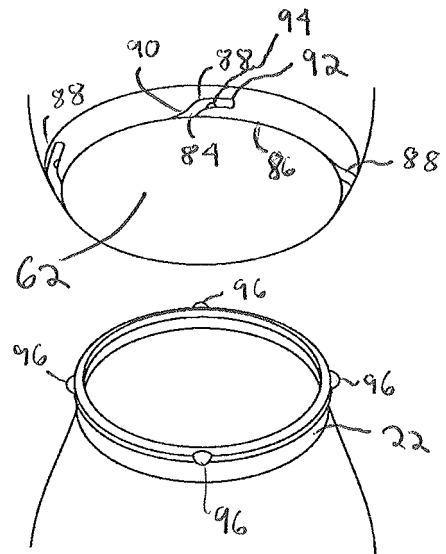

FIG. 11

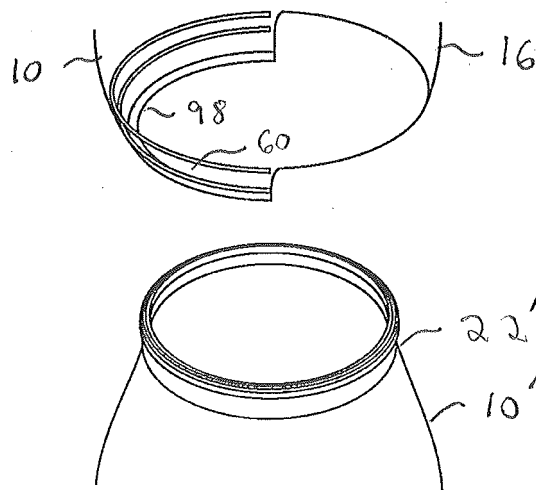

FIG. 12

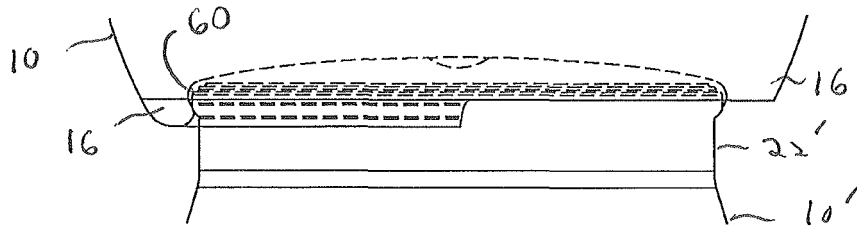

FIG. 12A

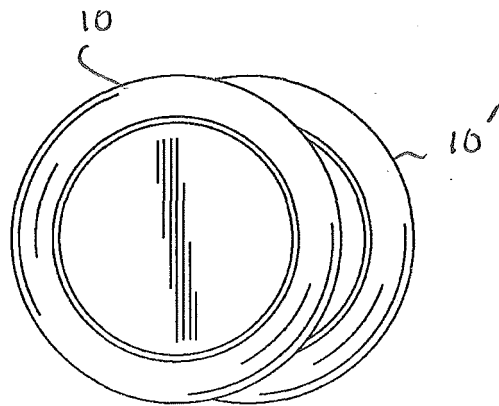

FIG. 12B

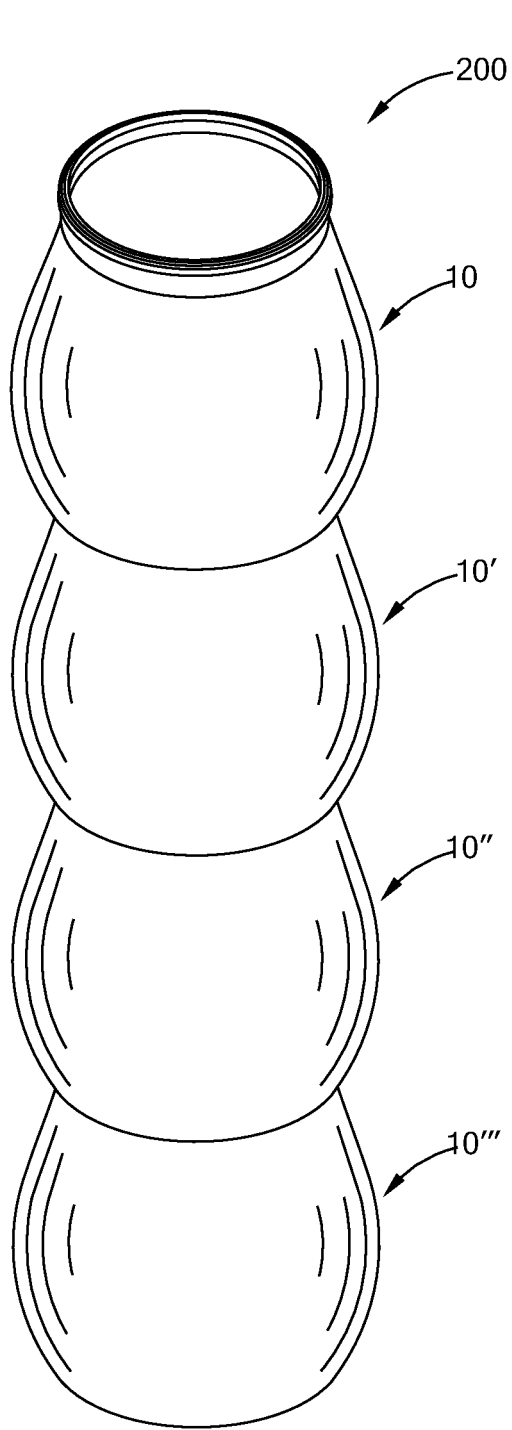

FIG. 13

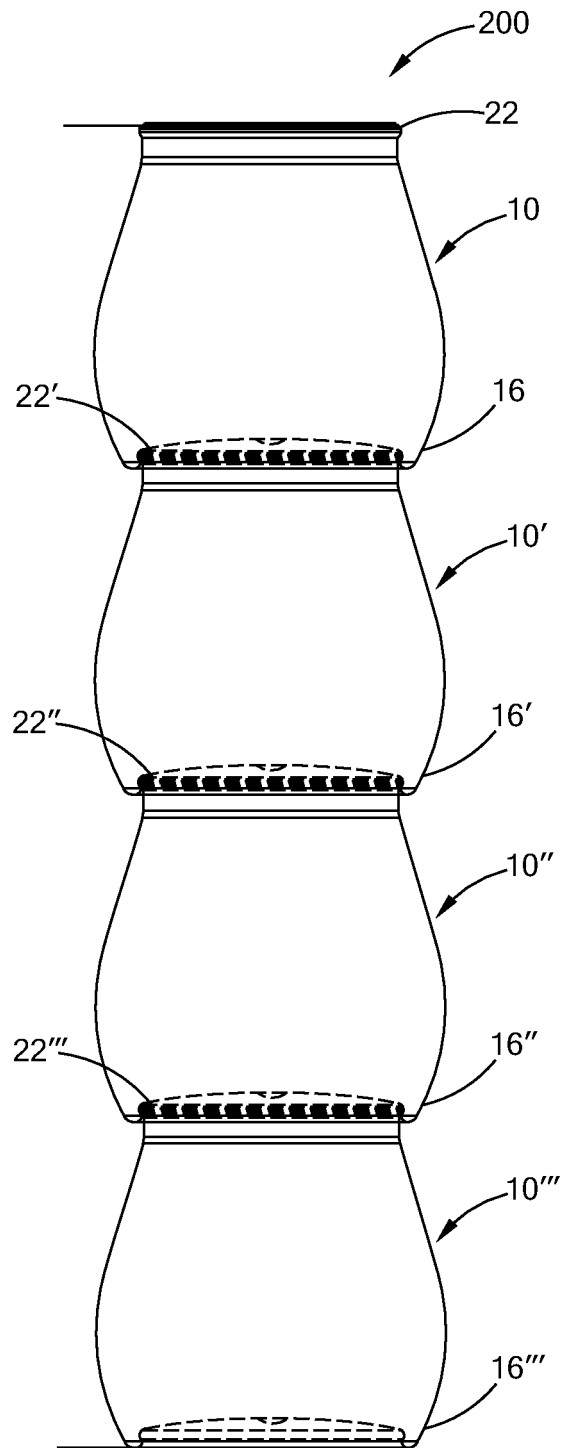

FIG. 14

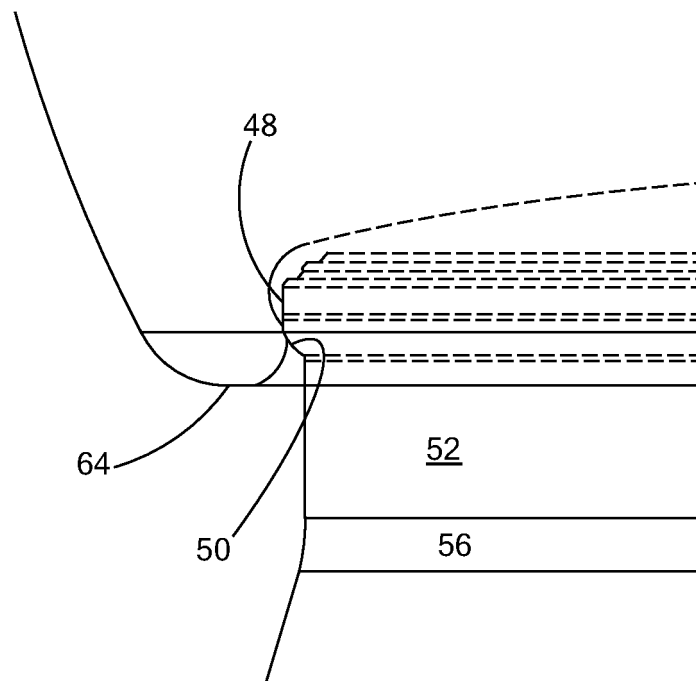

FIG. 15

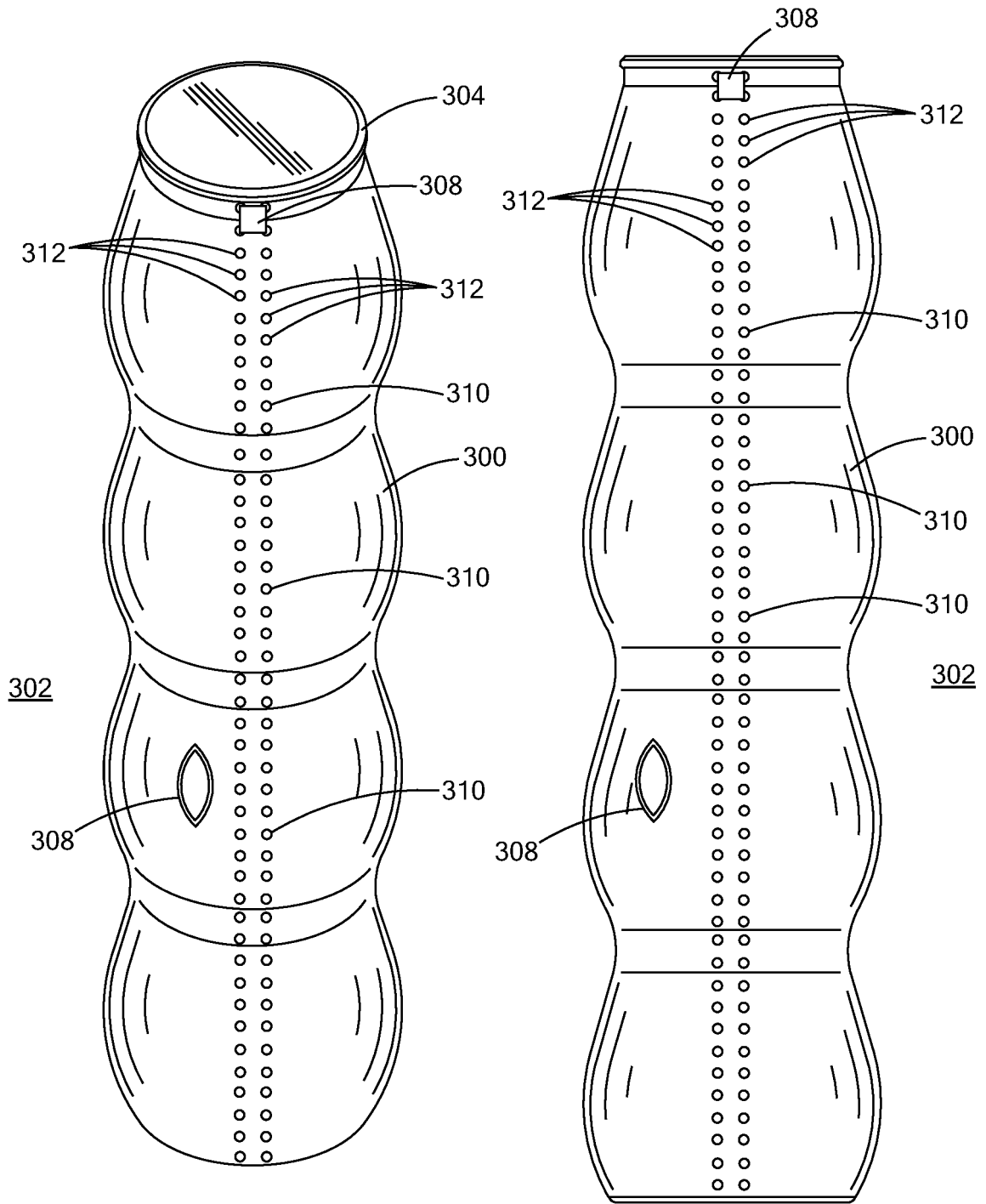

FIG. 16

FIG. 17

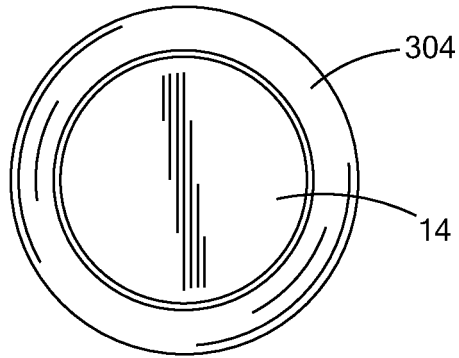

FIG. 18

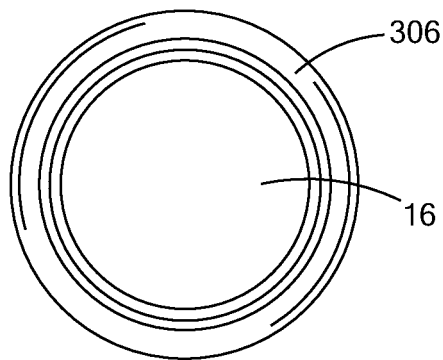

FIG. 19

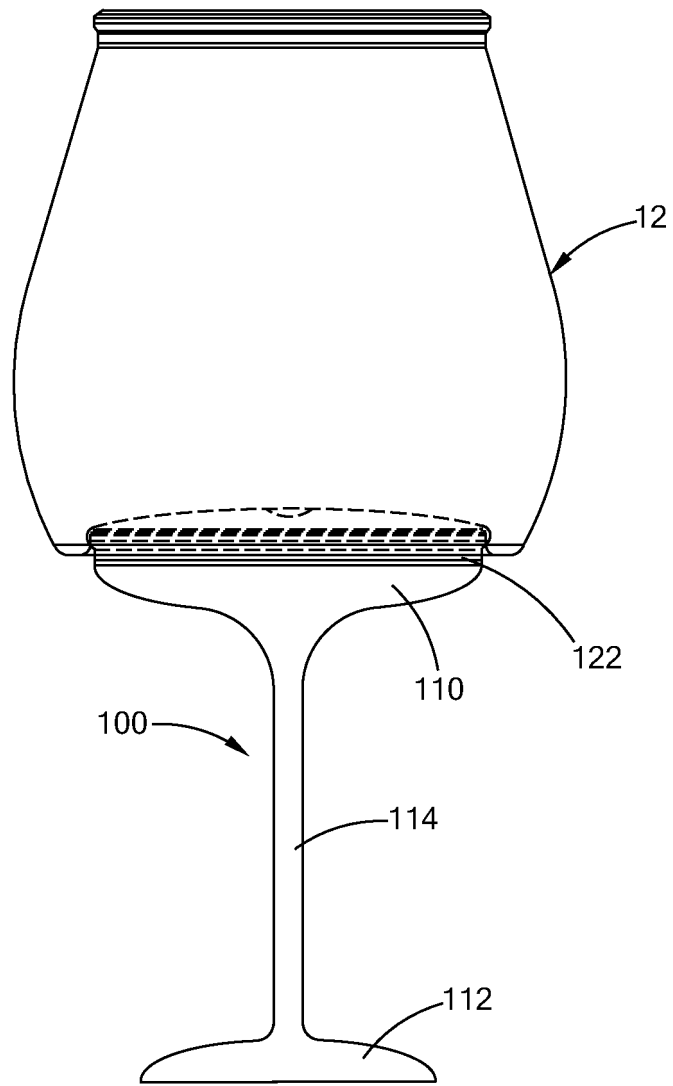

FIG. 20

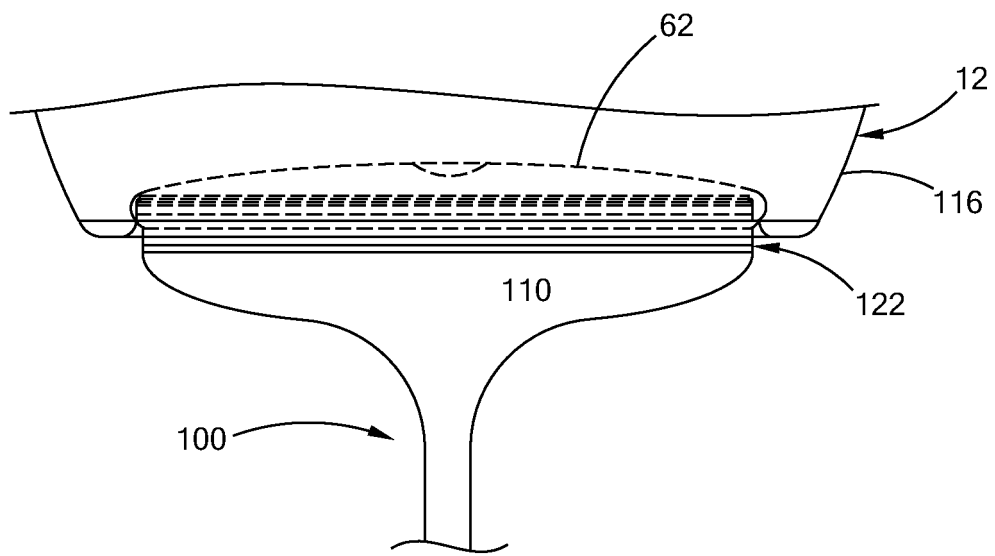

FIG. 21

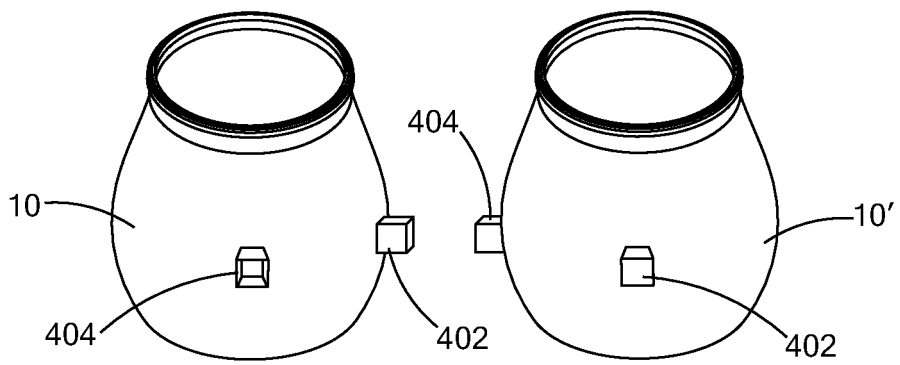

FIG. 22

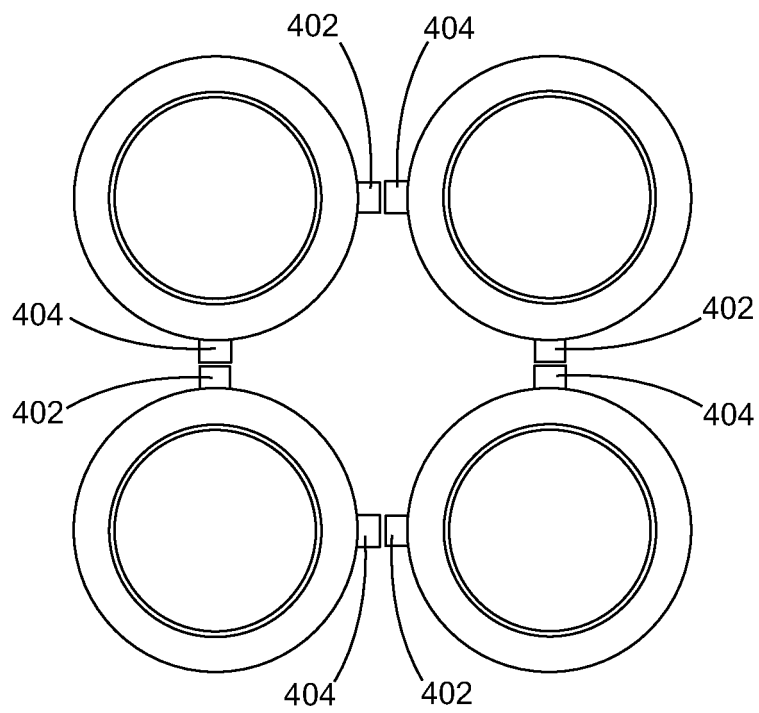

FIG. 23

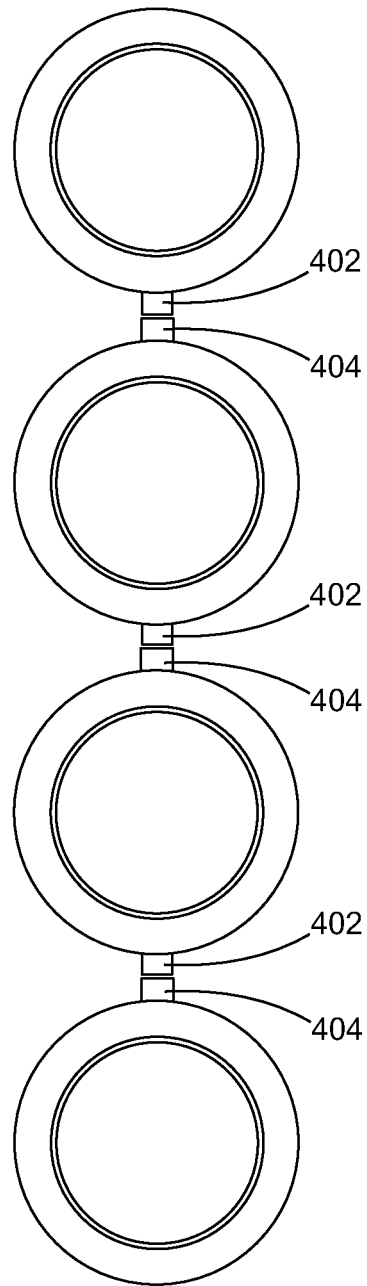

FIG. 24

REFERENCES CITED IN THE DESCRIPTION

This list of references cited by the applicant is for the reader's convenience only. It does not form part of the European patent document. Even though great care has been taken in compiling the references, errors or omissions cannot be excluded and the EPO disclaims all liability in this regard.

Patent documents cited in the description

- DE 29622585 U1 [0002]