

[54] SNAP-ON ONE PAIR BLOCK AND FRAMES THEREFOR

[76] Inventor: Frederick Frank Reinisch, 475 Scotia St., Winnipeg 17, Manitoba, Canada

[22] Filed: July 15, 1971

[21] Appl. No.: 162,845

[52] U.S. Cl. .... 339/198 G, 339/119 R

[51] Int. Cl. .... H01r 9/00

[58] Field of Search ..... 339/198, 119 R, 119 C, 339/119 L, 120, 121, 217 S; 211/26, 89, 13; 248/314, 361

[56] References Cited

UNITED STATES PATENTS

|           |         |                     |           |
|-----------|---------|---------------------|-----------|
| 3,576,520 | 4/1971  | Stauffer .....      | 339/198 G |
| 2,892,176 | 6/1959  | Gordon .....        | 339/198 G |
| 3,310,772 | 3/1967  | Kirk et al. ....    | 339/217 S |
| 3,456,231 | 7/1969  | Paullus et al. .... | 339/60    |
| 3,547,274 | 12/1970 | Sosinski .....      | 211/89    |

Primary Examiner—Marvin A. Champion

Assistant Examiner—Robert A. Hafer

Attorney—S. G. Ade et al.

[57] ABSTRACT

A stainless steel frame is installed and any number required up to six one-pair blocks can be snapped into place and connected.

1 Claim, 4 Drawing Figures

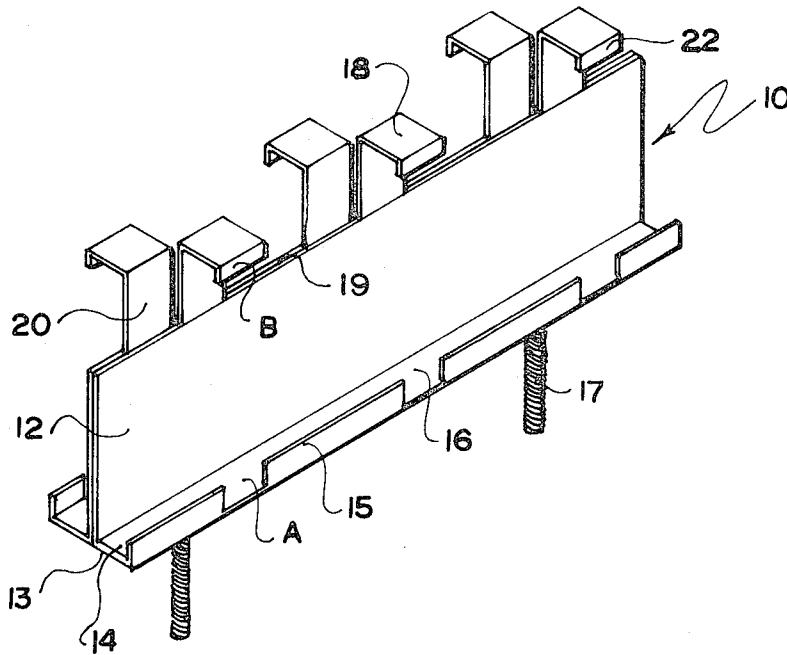

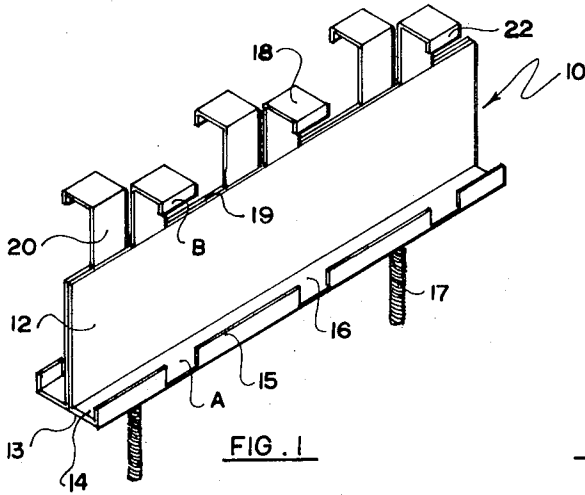

FIG. 1

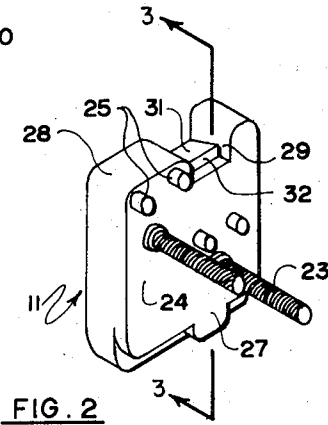

FIG. 2

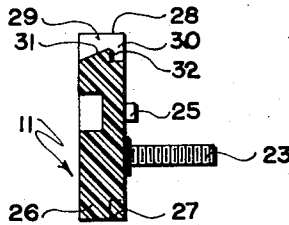

FIG. 3

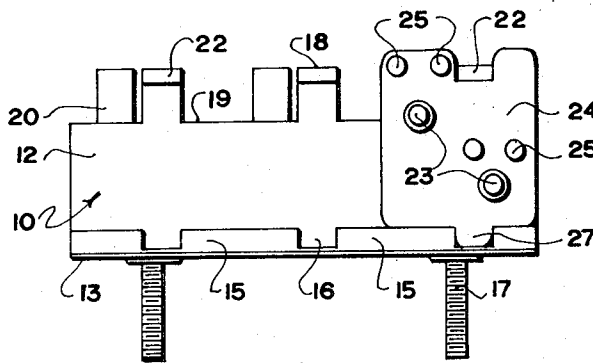

FIG. 4

INVENTOR.

FREDERICK FRANK REINISCH

BY

## SNAP-ON ONE PAIR BLOCK AND FRAMES THEREFOR

This invention relates to new and useful improvements in block and frame combination normally used or installed on buried or aerial plastic insulated cables.

Conventionally, an integral block and frame combination is provided with or without the leads being installed.

However, these unprotected block and frame devices normally only utilize one, two or three lines so that the balance of the leads or blocks in a six-pair block are not necessary, even although it is conventional to manufacture such devices as six-pair blocks.

The present device has several advantages of the existing constructions inasmuch as a simple frame is provided and installed together with snap-in one-pair blocks which can be added as desired. If the initial installation only requires three cables to be connected, then only three blocks need be installed at this time. If at a later date additional blocks are required, these are easily added by snapping new blocks into position and connecting leads to the cable.

This saves installation costs and also eliminates any possibility of damage occurring to the blocks or leads not used at the time of installation.

Even if all six lines are to be connected, there is no more cost or labor involved than utilizing a conventional six-pair block.

The frame is made preferably from stainless steel sheet and the blocks from an insulating plastic with the terminals moulded therein thus preventing electrical shorting due to moisture absorption.

The blocks are simply engaged with the base of the frame and then snapped into position so that a detent on the frame engages a detent recess on the block. This not only holds the block firmly in position, but enables it to be removed at any time if desired.

The device is simple in construction, economical in manufacture, and otherwise well suited to the purpose for which it is designed.

With the considerations and inventive objects herein set forth in view, and such other or further purposes, advantages or novel features as may become apparent from consideration of this disclosure and specification, the present invention consists of the inventive concept which is comprised, embodied, embraced, or included in the method, process, construction, composition, arrangement or combination of parts, or new use of any of the foregoing, herein exemplified in one or more specific embodiments of such concept, reference being had to the accompanying Figures in which:

FIG. 1 is an isometric view of the frame per se.

FIG. 2 is an isometric view of one of the blocks per se.

FIG. 3 is a sectional view substantially along the line 3—3 of FIG. 2.

FIG. 4 is a front elevation of the frame showing one block installed.

In the drawings like characters of reference indicate corresponding parts in the different figures.

Proceeding therefore to describe the invention in detail, reference character 10 illustrates generally the frame and reference character 11, one of the one-pair blocks.

Dealing first with the frame, it comprises a longitudinally extending central plate 12 having a base 13

formed or secured to the lower edge of this plate and extending at right angles upon each side thereof.

The base 13 includes a horizontal flange 14 and a plurality of upwardly extending vertical lips 15, said lips being positioned so that a space 16 is provided at intervals along the base of the frame.

Downwardly extending bolts 17 permit the frame to be attached to a supporting surface (not illustrated) which is conventional.

Resilient upper detent members 18 extend at right angles upon each side of the central plate 12 from the upper edge 19 thereof and each of these detents includes a vertical wall portion 20, a horizontal portion 21 and a downwardly extending catch portion 22 and these detents are situated substantially over the spaces 16 between the lips 15.

The block 11 is formed from an insulating plastic and is provided with a pair of terminals 23 moulded therein and extending outwardly from one face 24 thereof.

Adjacent each terminal and extending outwardly from face 24 is a pair of bosses 25 between which the leads (not illustrated) are placed when attaching same to the terminal post 23. Once the leads are clamped into position upon the post, they are prevented from inadvertent sideways movement by these bosses 25 thus preventing any shorts or crosses from occurring.

A shoulder 26 is formed on the lower edge of the block 11 and a locating boss 27 extends from this shoulder part-way along the length thereof as shown in FIG. 2.

Immediately above this shoulder and formed in the upper edge 28 of the block is a detent engaging recess 29.

This is formed with vertical walls 30 and an upwardly ramped base 31 which terminates in a downwardly extending vertical face 32 as shown in cross section in FIG. 3.

In operation, the frame is installed in the usual way and the block 11 is engaged by shoulder 26, within the base 13 of the frame and with the locating boss 27 engaging within the space 16 between adjacent lips 15. This correctly positions the block and prevents sideways movement from occurring.

The block is then pushed back against the central plate 12 so that the catch 13 of the detent 18 engages the ramp 31 within the detent recess 29. As the block is pushed into position, the detent is raised by the ramp until the lip 13 snaps over the upper limit of the ramp and down against the vertical face 32 which holds the block firmly in position within the frame. If it is desired to remove the block, the detent 18 has to be moved upwardly by means of a screw driver or the like thus permitting the block to be withdrawn.

Various modifications can be made within the scope of the inventive concept which is herein disclosed and/or claimed.

What I claim as my invention is:

1. A mounting frame for a plurality of juxtaposed electrical terminal blocks, each of which has a substantially rectangular body with a locating boss projecting forwardly from the base of the body and with the top of the body being provided with a recess having a forwardly and upwardly slanting ramp and a downwardly stepped front portion defining a vertical face at the front end of said ramp; said mounting frame compris-

3

4

ing a horizontally elongated vertical plate, a base flange provided at the lower edge of said plate and projecting forwardly therefrom, an upstanding lip provided at the forward edge of said base flange, said lip being formed intermediate the ends thereof with an upwardly open locating space whereby a terminal block may be positioned on said base flange between said vertical plate and said lip with the boss of the block located in said

space, and a resilient detent of an inverted J-shaped form projecting upwardly and forwardly from the upper edge of said vertical plate, said detent including a downturned free end portion which is snap-fittingly engageable over the ramp of a block body recess to abut the block face at the front end of the ramp to removably retain the block in position on said frame.

\* \* \* \* \*

10

15

20

25

30

35

40

45

50

55

60

65