

(19) World Intellectual Property
Organization
International Bureau



(43) International Publication Date
10 February 2005 (10.02.2005)

PCT

(10) International Publication Number
WO 2005/012129 A1

- (51) International Patent Classification⁷: **B65D 55/02**
- (21) International Application Number:
PCT/CA2004/001436
- (22) International Filing Date: 30 July 2004 (30.07.2004)
- (25) Filing Language: English
- (26) Publication Language: English
- (30) Priority Data:
60/491,702 1 August 2003 (01.08.2003) US
- (71) Applicant (for all designated States except US):
LIQUI-BOX CANADA INC. [CA/CA]; 201 South
Blair Street, Whitby, Ontario L1N 5S6 (CA).
- (72) Inventor; and
- (75) Inventor/Applicant (for US only): **JOHNSON, James**
[US/US]; 1516 Cheshire Road, Delaware, OH 43015 (US).
- (74) Agent: **OGILVY RENAULT**; Suite 1600, 1981 McGill
College Avenue, Montreal, Québec H3A 2Y3 (CA).
- (81) Designated States (unless otherwise indicated, for every
kind of national protection available): AE, AG, AL, AM,
AT, AU, AZ, BA, BB, BG, BR, BW, BY, BZ, CA, CH, CN,
CO, CR, CU, CZ, DE, DK, DM, DZ, EC, EE, EG, ES, FI,
GB, GD, GE, GH, GM, HR, HU, ID, IL, IN, IS, JP, KE,
KG, KP, KR, KZ, LC, LK, LR, LS, LT, LU, LV, MA, MD,
MG, MK, MN, MW, MX, MZ, NA, NI, NO, NZ, OM, PG,
PH, PL, PT, RO, RU, SC, SD, SE, SG, SK, SL, SY, TJ, TM,
TN, TR, TT, TZ, UA, UG, US, UZ, VC, VN, YU, ZA, ZM,
ZW.
- (84) Designated States (unless otherwise indicated, for every
kind of regional protection available): ARIPO (BW, GH,
GM, KE, LS, MW, MZ, NA, SD, SL, SZ, TZ, UG, ZM,
ZW), Eurasian (AM, AZ, BY, KG, KZ, MD, RU, TJ, TM),
European (AT, BE, BG, CH, CY, CZ, DE, DK, EE, ES, FI,
FR, GB, GR, HU, IE, IT, LU, MC, NL, PL, PT, RO, SE, SI,
SK, TR), OAPI (BF, BJ, CF, CG, CI, CM, GA, GN, GQ,
GW, ML, MR, NE, SN, TD, TG).
- Published:
— with international search report
- For two-letter codes and other abbreviations, refer to the "Guidance Notes on Codes and Abbreviations" appearing at the beginning of each regular issue of the PCT Gazette.

(54) Title: TAMPER EVIDENT FITMENT ASSEMBLY

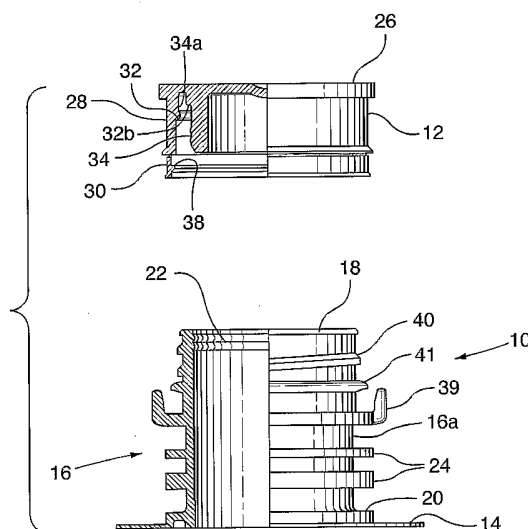

(57) Abstract: A tamper evident fitment assembly for use with a container for flowable material, the closure comprising a cap and a spout secured to the container, the cap having a frangible tamper evident band, the cap having an annular recess for frictionally engaging a top portion of the spout, the cap and spout having cooperating detent and locking elements so that the assembly in a first position where the cap is removably sealed to the spout and the tamper evident band is not broken when the cap is removed for filling may move to a second position when the cap is removably sealed to the spout and the tamper evident band is broken upon removal of the cap. An important feature of the present invention is that the cap frictionally engages a top portion of the spout. No screw threads or similar securing means are required to retain the cap on the spout.

WO 2005/012129 A1

TAMPER EVIDENT FITMENT ASSEMBLY

FIELD OF THE INVENTION

The present invention provides a tamper evident fitment assembly and more particularly a tamper evident fitment assembly for use in aseptic packaging applications.

BACKGROUND OF THE INVENTION

Many systems are used for filling and dispensing liquids and other flowable products from packages produced under aseptic conditions. Generally these packages are made from a plastic material and have at least one spout through which the liquid or flowable material is filled and dispensed. It is critical that package or seal tampering be readily apparent upon inspection for aseptically packaged food products, and the tampering indicator must be robust enough to withstand the packaging, transporting, filling and sealing conditions. The packaging used in these circumstances is relatively inexpensive and is only meant for single use. Nevertheless it is important that such packaging maintain its aseptic integrity until the packaged goods are consumed and any failure of the aseptic or hermetic seal prior to use of the package contents must be readily apparent. Generally it is preferred that these packages be kept under aseptic conditions throughout the manufacturing and filling process, as well as prior to dispensing of the liquid or flowable product. Such conditions may be required if the flowable product will readily undergo deterioration or degradation when exposed to a non-aseptic environment.

Often the systems used for packaging under aseptic conditions involve the production of the bag and fitment at one facility and then transporting them to a second facility for filling during which the bag is then placed in an aseptic environment. It can be difficult to maintain such aseptic conditions throughout this process.

- 2 -

It is therefore desirable to provide a tamper evident fitment assembly for use in aseptic applications that addresses the requirements discussed above.

SUMMARY OF THE INVENTION

5 The present invention provides a tamper evident closure and dispensing assembly that includes a spout and a cap with a tamper indicating band that may be assembled into a pre-cap position and attached to a container under sterile/aseptic conditions and transported to a filling facility. During
10 transportation the pre-cap position will maintain the container in an aseptic condition. When filling of the container is required, the container is placed in a filling station which is maintained under aseptic conditions and the cap is removed from the spout. The container is then filled and the cap is placed back on the spout in a full cap position. Removal of the cap from the full cap position will separate the tamper indicating band from the cap thereby
15 indicating that the seal on the container has been broken.

15 The present invention provides a tamper evident closure and dispensing assembly for use with a fluid dispensing container for flowable material. The assembly comprises a spout for attachment to a container, the spout having an upper end and a lower end, and having a dispensing passage
20 therethrough. The assembly further comprises a cap having a top with an external depending skirt and a tamper indicating band releasably attached to the skirt. The cap further including an internal skirt depending from the top and spaced inwardly from the external skirt and operable to be received within the fluid passage to provide a seal between the cap and the spout. The
25 assembly has a first position in which the cap is received on the upper end of the spout with the tamper indicating band abutting the external rib and the internal skirt being received within the passage and providing a seal therebetween, and a second position in which the cap is located on the lower end of the spout with the external rib located between the external skirt and the tamper indicating band and the upper end of the spout located adjacent

- 3 -

the top of the cap, the internal skirt being received within the passage and providing a seal there between.

The present invention further provides a tamper evident closure and dispensing assembly comprising a spout having an upper end and a lower
5 end, the spout defining a dispensing passage therethrough and a cap sized to be received on the spout and having a tamper indicating band releasably attached thereto. The assembly has a first position in which the cap and the tamper indicating band are received on the upper end of the spout and a seal is provided between the cap and the spout and from which when the cap is
10 removed the tamper indicating band remains attached to the cap, and a second position in which the cap and the tamper indicating band are located adjacent the lower end of the spout and a seal is provided between the cap and the spout and from which when the cap is removed the tamper indicating band detaches from the cap and remains on the spout, thereby providing
15 evidence that the assembly has been tampered with.

An important feature of the present invention is that the cap frictionally engages a top portion of the spout. No screw threads or similar securing means are required to retain the cap on the spout.

In another aspect of the invention there is provided a tamper evident closure
20 and dispensing assembly for use with a container for flowable material, the closure comprising a cap and a spout secured to the container, the cap having a frangible tamper evident band associated with it, the cap having an annular recess for frictionally engaging and retaining a top portion of the spout, the cap and spout having cooperating detent and locking elements to
25 allow the assembly, when secured to a container to move from a first position where the cap is removably sealed to the spout and the tamper evident band is not broken when the cap is removed for filling, to a second position when the cap is removably sealed to the spout and the tamper evident band is broken upon removal of the cap to dispense flowable material.

- 4 -

In another aspect of the invention there is provided a tamper evident closure and dispensing assembly, wherein the cap includes an internal skirt depending from a top portion of the cap and spaced inwardly from the cap sidewall, the frangible tamper evident band depends from the lower edge of the cap sidewall and the area between the sidewall and the internal skirt forms the annular recess in the cap and includes a lower and an upper detent that determine the pre-cap and full cap positions, respectively for the top portion of the spout that is sealingly engaged within the annular recess of the cap when the assembly is in use.

5
10
15
In another aspect of the invention there is provided a tamper evident closure and dispensing assembly, wherein the cap includes a locking ring that cooperatively and removably engages an annular projection located on an inner edge of the tamper evident band in the pre-cap position and in the full cap position the annular projection located on an inner edge of the tamper evident band is engaged beneath the locking ring, whereby in the pre-cap position the frangible tamper evident band is not broken upon removal of the cap, but in the full cap position, the frangible tamper evident band must be broken to remove the cap.

20
25
In another aspect of the invention there is provided a tamper evident closure and dispensing assembly, wherein the cap includes a locking ring and at least one tab that cooperatively engage and lock an annular projection located on an inner edge of the tamper evident band in the pre-cap position and in the full cap position the annular projection located on an inner edge of the tamper evident band is engaged and locked between the locking ring and the at least one tab, whereby in the pre-cap position the frangible tamper evident band is not broken upon removal of the cap, but in the full cap position, the frangible tamper evident band must be broken to remove the cap.

DESCRIPTION OF THE DRAWINGS

The present invention is better understood with reference to the attached description and to the following Figures, wherein:

5 Figure 1A illustrates a front view of one embodiment of the tamper evident fitment assembly of the present invention in a ready to assemble position.

Figure 1B illustrates a side partial cross sectional view of the tamper evident fitment assembly of Figure 1A;

Figure 1C illustrates a side view of the embodiment of Figure 1A;

10 Figure 2A illustrates a front view of the tamper evident fitment assembly of Figure 1A in a pre-cap position;

Figure 2B illustrates a side partial cross sectional view of the tamper evident fitment assembly of Figure 2A;

Figure 3 illustrates a side partial cross sectional view of the tamper evident fitment assembly of Figure 1A in the filling position;

15 Figure 4A illustrates a front view of the tamper evident fitment assembly of Figure 1A in a full cap position;

Figure 4B illustrates a side partial cross sectional view of the tamper evident fitment assembly of Figure 4A;

20 Figure 5 illustrates a side partial cross sectional view of the tamper evident fitment assembly of Figure 1 in a dispensing position; and

Figure 6 illustrates a front view of an alternative embodiment of the tamper evident fitment assembly.

DETAILED DESCRIPTION OF THE INVENTION

The tamper evident fitment assembly of the present invention will now be described with reference to Figures 1A through 6 in which one embodiment of the tamper evident fitment assembly is indicated generally at numeral 10. The
5 tamper evident fitment assembly 10 is connected to a container that is filled with flowable material, e.g. liquids. It will be understood by a person skilled in the art that generally a container for such use may be in the form of a pouch. As used herein, the term "*flowable* material" does not include gaseous materials, but encompasses materials which are *flowable* under gravity or
10 may be pumped. Such materials include liquids, preferably foods, such as water, fruit juice, milk, oil; emulsions e.g. ice cream mix, soft margarine; pastes e.g. meat pastes, peanut butter; preserves e.g. jams, pie fillings, marmalade; jellies; doughs; ground meat e.g. sausage meat; powders e.g. gelatine powders, detergents; granular solids e.g. nuts, sugar, and like
15 materials. The invention described herein is particularly useful for *flowable* foods.

The tamper evident fitment assembly 10 of the present invention may be used on a container that requires handling and filling in an aseptic environment. The fitment assembly and its use will be described in such an environment.
20 However, it will be understood by a person skilled in the art, that the use of the fitment assembly of the present invention is not limited to such a use and other applications fall within the scope of the invention.

The tamper evident fitment assembly 10 includes a cap 12 and a spout 16 having an annular flange 14 at its base that is operable for attachment to a
25 container, not shown. The attachment of the flange 14 to a container can be achieved many ways that will be known to a person skilled in the art. Examples of ways to attach the flange 14 to the fitment include, but are not limited to, heat sealing, welding and chemical bonding, e.g. adhesive. The cap 12 is sized to be received on the spout 16, and can be located on the spout
30 16 in several different positions in which hermetic sealing between the cap 12

- 7 -

and the spout 16 is maintained to provide an aseptic environment. The positions include an aseptic pre-cap position and an aseptic full cap position, which will be described further below.

5 As can be seen more clearly in Figures 2 through 6, the spout 16 has an upper end 18 and a lower end 20 and a central passage 22 through the spout 16 between the upper end 18 and the lower end 20 for passage of flowable material.

10 In the illustrated embodiment, the spout 16 also includes a series of different sized valve engagement rings 24 that allow the spout and hence the container to be secured to a variety of fillers or dispensers, not shown. The size and location of each ring 24 may be selected in accordance with the type of filler and/or dispenser the spout 16 is attached to. It will be understood by a person skilled in the art that the positioning and size of the rings 24 may be varied for optimizing the securing of the spout 16 to such apparatus. Spout regions 16a
15 are provided between the valve engagement rings 24 to receive and secure the dispensing or filler valves. The spout 16 may include two valve engagement rings 24; however it will be understood by a person skilled in the art that the number may vary depending on the end use of the container and fitment assembly 10. The spout 16 may also include external threads 40 for a
20 threaded connection of the spout 16 to a dispensing connector.

As described above, the cap 12 is sized to be received on the spout 16 and includes a top 26 with an external skirt 28 depending from the top 26 and a tamper indicating band 30 releasably attached to the external skirt 28 at the opposite end from the top 26. The external skirt 28 has an internal ledge 32
25 located adjacent the top 26 of the cap 12, distal from the tamper indicating band 30. The cap 12 further includes a cork 34, also referred to as an internal skirt, depending from the top and spaced inwardly from the external skirt 28. The cork 34 is sized to be received within the fluid passage 22 of the spout 16 to provide a seal between the cap 12 and the spout 16 when the cap 12 is
30 received on the spout 16.

- 8 -

As can be seen in Figure 3, the internal skirt 34 is spaced from the external skirt 28 providing a space 34a that is sized to allow the spout 16 to fit therebetween. The spacing is sufficient to allow the spout 16 to be placed between the internal skirt 34 and the external skirt 28 and to be held in place by a friction fit and thereby providing a seal therebetween that is sufficient to maintain an aseptic seal for the container. Space 34a is configured with a lower internal ledge or detent 32 and an upper internal ledge or detent 32b, against which the top of the spout 16 sealingly engages the cap 16 to provide the aseptic seals in the pre-cap and full cap positions as will be described in more detail below.

As discussed above, the cap 12 includes a tamper indicating band 30 releasably attached to the external skirt 28. The tamper indicating band 30 is attached to the external skirt 28 by a series of frangible bridges 36. The frangible bridges 36 are integrally formed with the cap 12 and band 30.

Located on the internal surface of the tamper indicating band 30 is a shoulder 38 that extends inwardly and is located at a distance from the external skirt 28. The shoulder may be continuous around the band perimeter or be interrupted and functions as a tamper evident ring lock as will be described below. The exterior of spout 16 includes a circumferential lip 18. External screw threads 40 are located just below the lip 18. An annular locking ring 41 is located just below the screw threading 40. Locking ring 41 may be continuous or interrupted also. Spaced from and below the locking ring 41 is at least one tab 39, which cooperates with locking ring 41 to engage and retain tamper evident ring lock 38, when the cap 12 is positioned on the spout 16. The at least one tab 39 may be a continuous annular ring or it may comprise a plurality of tabs spaced about the circumference of the spout 16. In Figure 1C a side view of the fitment illustrates a shape of the tab 39. It will be noted that this tab may not be necessary for all applications and Figure 6 illustrates an embodiment of the fitment that does not include a tab 39. Below the at least one tab 39 are the two valve engagement rings 24. As indicated previously, these rings 24 permit a variety of dispensing or filler valves, not

shown to be secured to the spout. Finally, below the rings 24 is the base 20 or bottom of the spout 16 which includes the flange 14 by which the spout 16 may be secured to a container, not shown, by well known means. The distance between the shoulder or ring lock 38 and the external skirt 28 in the cap 12 is sized to receive at least a portion of the external rib 39 therebetween.

As can be seen in Figures 2 through 6, the cap 12 and the spout 16 have many possible positions during the use of the fitment 10. The positions of the cap 12 and the spout 16 will be discussed in order of the operation of the fitment beginning with a ready to assemble position to a dispensing position. In all of the positions discussed the spout 16 is attached to a container, not shown, by means that are known to a person skilled in the art.

Figure 2 illustrates the ready to assemble position in which the cap 12 is not yet placed on the spout 16. In this position the tamper indicating band 30 is connected to the external skirt 28 of the cap 12 by frangible bridges 36.

Turning to Figure 2B, the pre-fill position is shown. As can be seen, the cap 12 is received on the spout 16 with the tamper indicating band 30 being located adjacent the locking ring 41. Shoulder 38 rests against locking ring 41; while lip 18 of the spout is frictionally and sealingly engaged by ledge 32 in the area 34a of cap 12. In this pre-fill position the tamper indicating band 30 is connected to the external skirt 28 of the cap 12 by frangible bridges 36. The positioning of the internal skirt 34 within the passage 22 adjacent the internal ledge 32, will maintain an aseptic seal between the cap 12 and the spout 16.

In order to fill the container with the required flowable material the cap 12 must be removed from the spout 16 in order to allow for the flowable material to pass through the passage 22. The cap 12 is removed from the spout 16, as shown in Figure 3, while maintaining the connection between the tamper indicating band 30 and the external skirt 28 of the cap 12. The container may

- 10 -

then be filled by means known by a person skilled in the art, an example of which is described below.

Once the container has been filled, the cap 12 is then placed back onto the spout 16. Figure 4B illustrates the assembly at this time which may be called the full cap or post fill position. At this stage the cap 12 is generally not removed from the spout 16 until dispensing of the product from the container is required. Since any tampering with the container and fitment assembly 10 at this stage may contaminate the contents of the container it is desirable to show whether the fitment assembly 10 has been tampered with. Figure 4B illustrates the full cap position in which an aseptic environment for the fitment assembly 10 and the contents of the container may be maintained. If the cap 12 is removed from the fitment assembly 10 when in the full cap position the tamper evident band 30 will separate, as described below, indicating that tampering has occurred and providing the required signal upon inspection.

When the cap 12 is placed on the spout 16 in the full cap position the cap 12 is moved further onto the spout 16 towards the flange 14 than in the previously described pre-cap position, illustrated in Figure 2B. In the full cap position, the cap 12 is positioned with the shoulder 38 of the tamper indicating band 30 located below the rib 41 and the frangible bridges 36 are located adjacent the peripheral edge of the external rib 39. In this position the upper end or lip 18 of the spout 16 is located above the internal ledge 32 of the external skirt 28 on the cap 12. Similar to the pre-cap position, in the full cap position, the location of the internal skirt 34 in the passage 22 creates a seal between the cap 12 and the spout 16 and provides an aseptic environment for the container, its contents and fitment assembly 10.

When the flowable material is required to be dispensed from the container the cap 12 must be removed from the spout 16. Figure 5 illustrates the cap 12 and spout 16 once the cap 12 has been removed from the spout 16. In this dispensing position, the cap 12 has been pulled away from the spout 16 in order to allow for the removal of material from the container. As the cap 12 is

- 11 -

pulled away from the spout 16 the shoulder 38 will abut against the external rib 39 which will inhibit the upward movement of the shoulder 38 and thereby inhibit the removal of the tamper indicating band 30 from the spout 16. The force that is applied on the cap 12 to pull it away from the spout 16 while the shoulder 38 of the tamper indicating band 30 is retained beneath the external rib 39 will apply pressure to the frangible bridges 36. Once sufficient pressure/force has been applied to the cap 12 the frangible bridges 36 will sever and the tamper indicating band 30 will become detached from the cap 12. The cap 12 can then be removed and the material in the container dispensed. The tamper indicating band 30 will remain on the spout 16 beneath the external rib 39 and indicate to a user that the fitment assembly 10 has been tampered with. The tamper indicating band 30 may subsequently be removed if required by the user.

The assembly and use of the tamper evident fitment assembly 10 will now be briefly discussed. The spout 16 and cap 12 are manufactured separately by suitable means known in the art. After manufacture the spout 16 and cap 12 are shipped to the container manufacturing location. The spout 16 is attached to the container, not shown, at flange 14 by suitable means known in the art. After attachment of the spout 16, the cap 12 is placed on the spout 16 in the pre-cap position, described above. The container and fitment assembly 10 are irradiated, by suitable means known in the art, in order to create an aseptic environment in the container. The container with the fitment assembly 10 may then be shipped to a filling station. When filling of the container is required, the container is placed in a filling machine, which operates under aseptic conditions. Once in the filling machine a capper apparatus will remove the cap 12 from the pre-cap position with the tamper indicating band 30 still attached to the cap 12. The filling machine will then fill the container with flowable material through the fluid passage 22 until the container is full. At this time, the cap 12 will be placed back onto the spout 16 and pushed into the full cap position. The container may then be removed from the filling machine and stored or shipped, as required. When the cap 12 is removed from the full cap

- 12 -

position the tamper indicating band 30 will separate from the external skirt 28 thereby indicating that the fitment assembly 10 has been tampered with. The types of filling machines and the operation of such machines will be understood by a person of skill in the art.

- 5 The fitment assembly 10 may be made from any suitable material known by a person skilled in the art. For example, the spout 16 and the cap 12 may be made from any suitable plastic, in particular any plastic suitable for injection molding, which will be known by a person skilled in the art. Examples include, but are not limited to, linear low density polyethylene and polypropylene.
- 10 Generally the cap may be made of a plastic that has sufficient flexibility to allow the spout 16 to move past the lower indent 32 to achieve the full cap position.

It will also be understood by a person skilled in the art that the dimensions of the spout 16 and cap 12 may vary depending on the filling machine with which
15 the container is to be used. When varying the dimensions the relative size of the spout 16 to the cap 12 must be maintained in order to provide the friction fit between the two and thereby maintaining an aseptic environment when required.

Although the invention has been described in terms of a particular preferred
20 embodiment thereof, the skilled practitioner will understand that variations may be made within the scope of the appended claims.

CLAIMS:

1. A tamper evident assembly for use with a fluid dispensing container for flowable material, the assembly comprising:

an annular flange for attachment to a container,

- 5 a spout projecting upwardly from the flange and having an upper end and a lower end, the spout defining a dispensing passage therethrough and having at least one external annular rib; and

- 10 a cap having a top with an external depending skirt and a tamper indicating band releasably attached to the skirt, the cap further including an internal skirt depending from the top and spaced inwardly from the external skirt and operable to be received within the fluid passage to provide a seal between the cap and the spout;

- 15 the assembly having a first position in which the cap is received on the upper end of the spout with the tamper indicating band abutting the external rib and the internal skirt being received within the passage and providing a seal therebetween, and a second position in which the cap is located on the lower end of the spout with the external rib located between the external skirt and the tamper indicating band and the upper end of the spout located adjacent the top of the cap, the
20 internal skirt being received within the passage and providing a seal therebetween.

2. A tamper evident assembly for use with a fluid dispensing container for flowable material, the assembly comprising:

an annular flange for attachment to a container,

- 25 a spout projecting upwardly from the flange and having an upper end and a lower end, the spout defining a dispensing passage therethrough; and

- 14 -

a cap sized to be received on the spout and having a tamper indicating band releasably attached thereto,

5 the assembly having a first position in which the cap and the tamper indicating band are received on the upper end of the spout and a seal is provided between the cap and the spout and from which when the cap is removed the tamper indicating band remains attached to the cap, and a second position in which the cap and the tamper indicating band are located adjacent the lower end of the spout and a seal is provided between the cap and the spout and from which when the cap is removed the tamper indicating band detaches from the cap and remains on the spout, thereby providing evidence of tampering.

- 10
- 15
- 20
- 25
3. A tamper evident closure and dispensing assembly for use with a container for flowable material, the closure comprising a cap and a spout secured to the container, the cap having a frangible tamper evident band associated with it, the cap having an annular recess for frictionally engaging a top portion of the spout, the cap and spout having cooperating detent and locking elements to allow the assembly, when secured to a container to move from a first position where the cap is removably sealed to the spout and the tamper evident band is not broken when the cap is removed for filling, to a second position when the cap is removably sealed to the spout and the tamper evident band is broken upon removal of the cap to dispense flowable material.
 4. A tamper evident closure and dispensing assembly according to claim 3, wherein the cap includes an internal skirt depending from a top portion of the cap and spaced inwardly from the cap sidewall, the frangible tamper evident band depends from the lower edge of the cap sidewall and the area between the sidewall and the internal skirt forms the annular recess in the cap and includes a lower and an upper detent that determine the pre-cap and full cap positions, respectively for the

- 15 -

top portion of the spout that is sealingly and frictionally engaged within the annular recess of the cap when the assembly is in use.

5. A tamper evident closure and dispensing assembly according to claim 4, wherein the cap includes a locking ring that cooperatively engages an annular projection located on an inner edge of the tamper evident band in the pre-cap position and in the full cap position the annular projection located on an inner edge of the tamper evident band is engaged beneath the locking ring, whereby in the pre-cap position the frangible tamper evident band is not broken upon removal of the cap, but in the full cap position, the frangible tamper evident band must be broken to remove the cap.

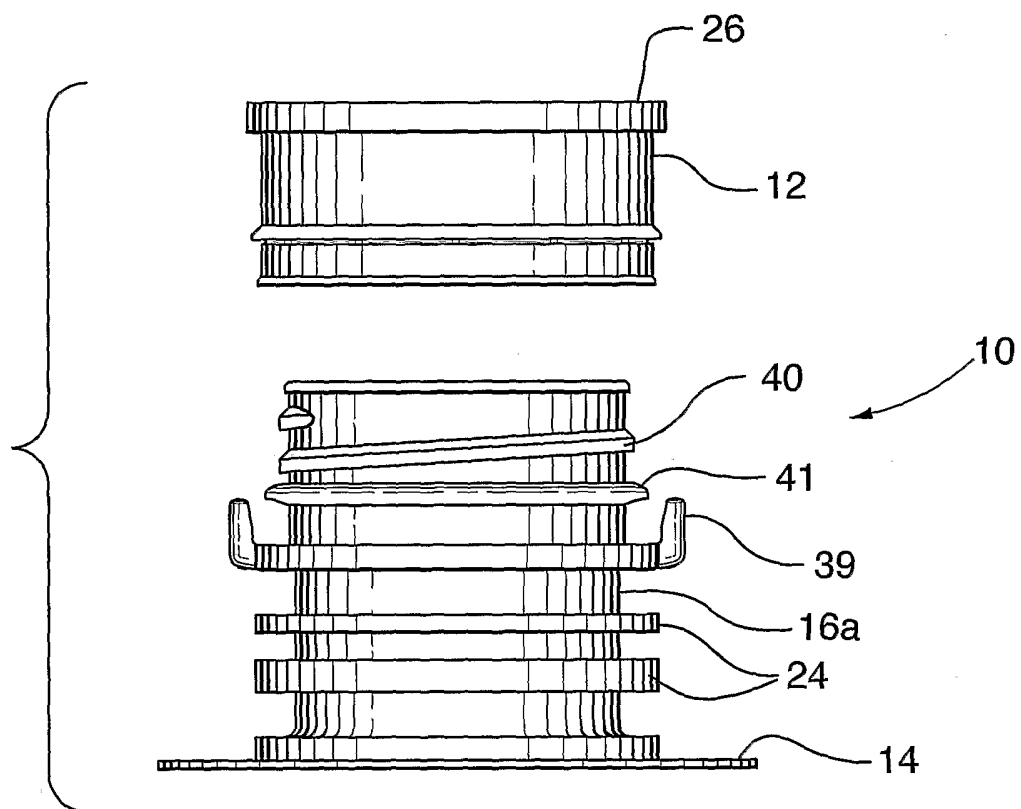

FIG.1A

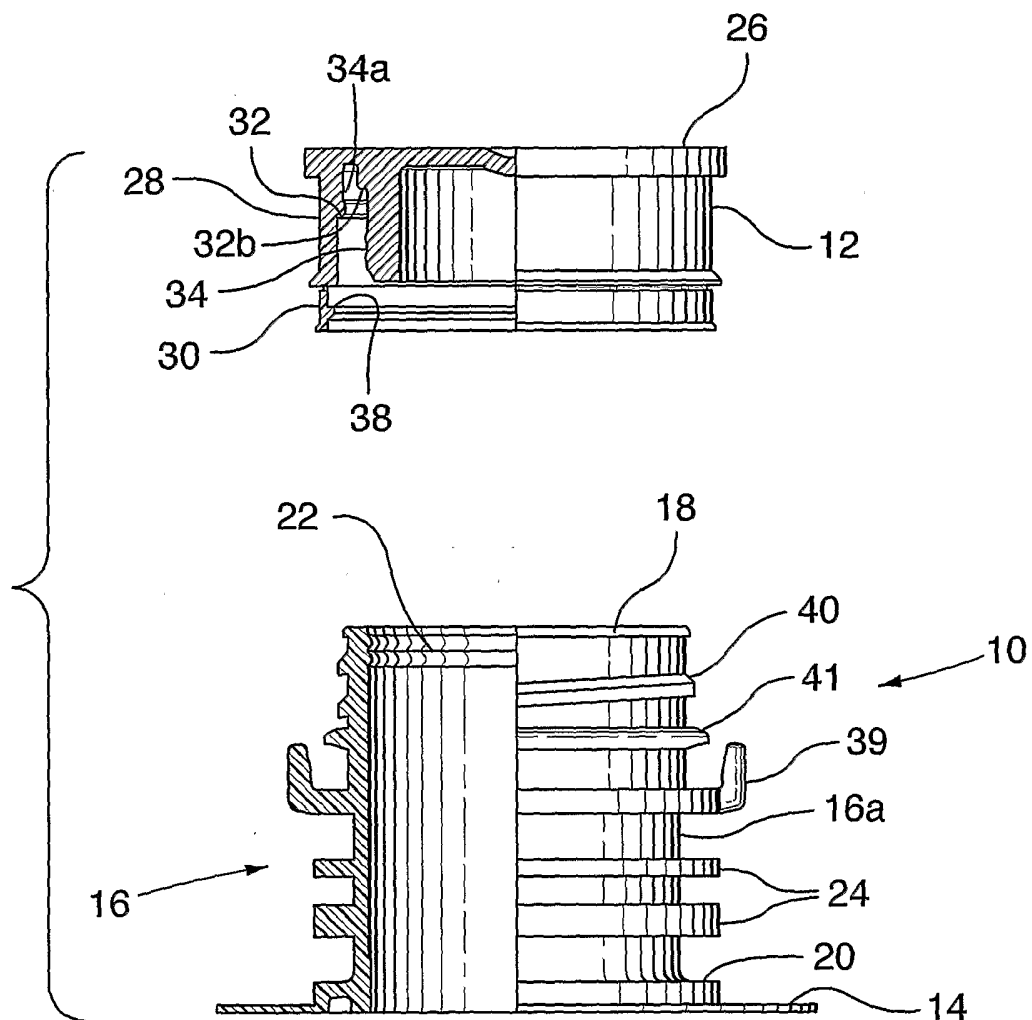

FIG. 1B

3/7

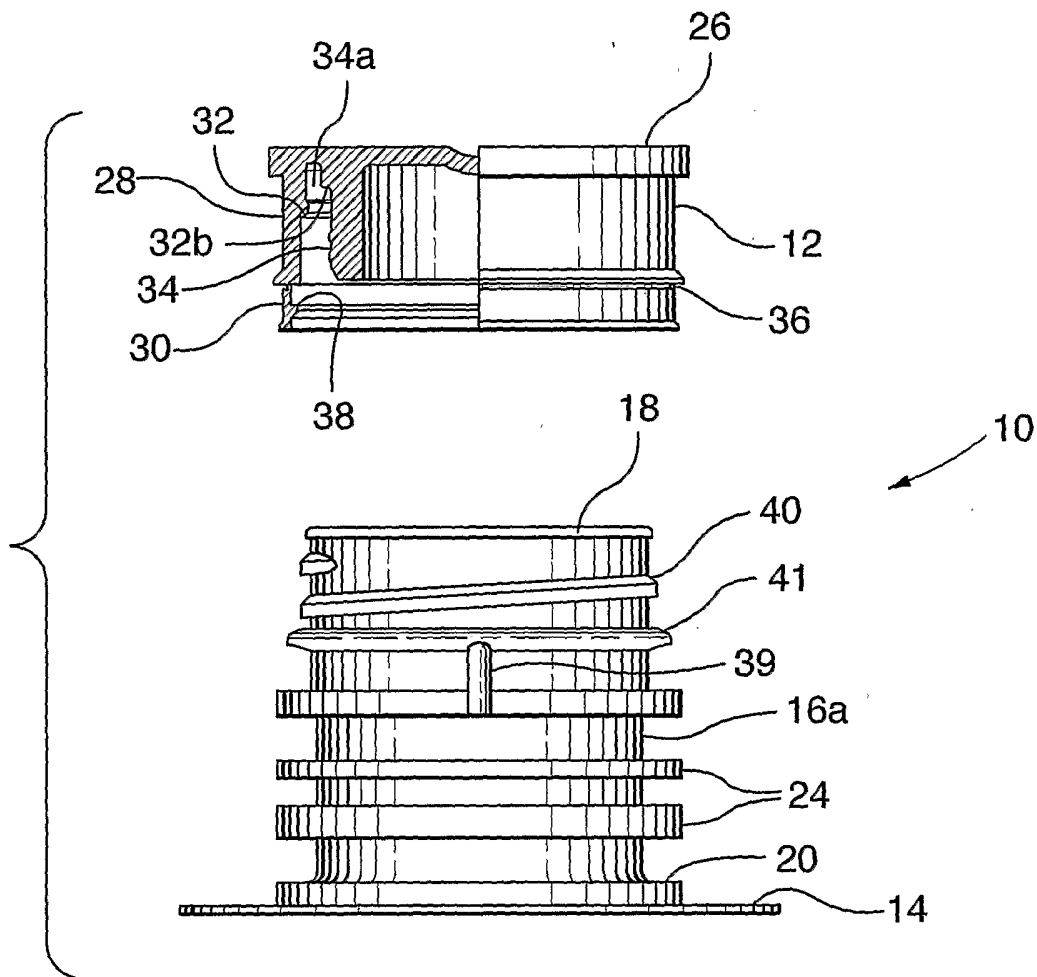

FIG.1C

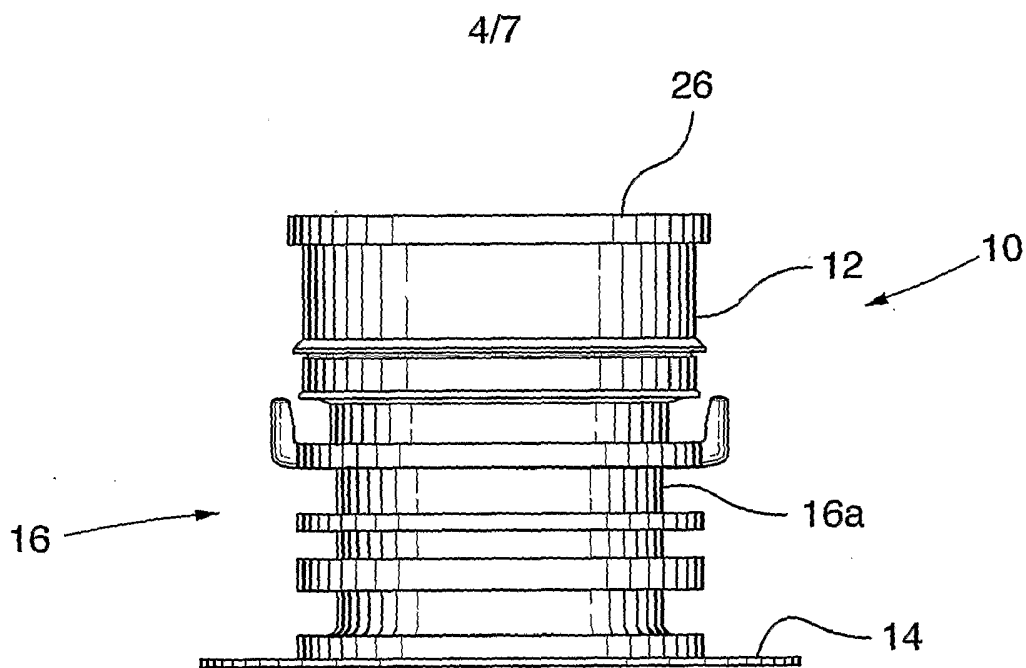

FIG.2A

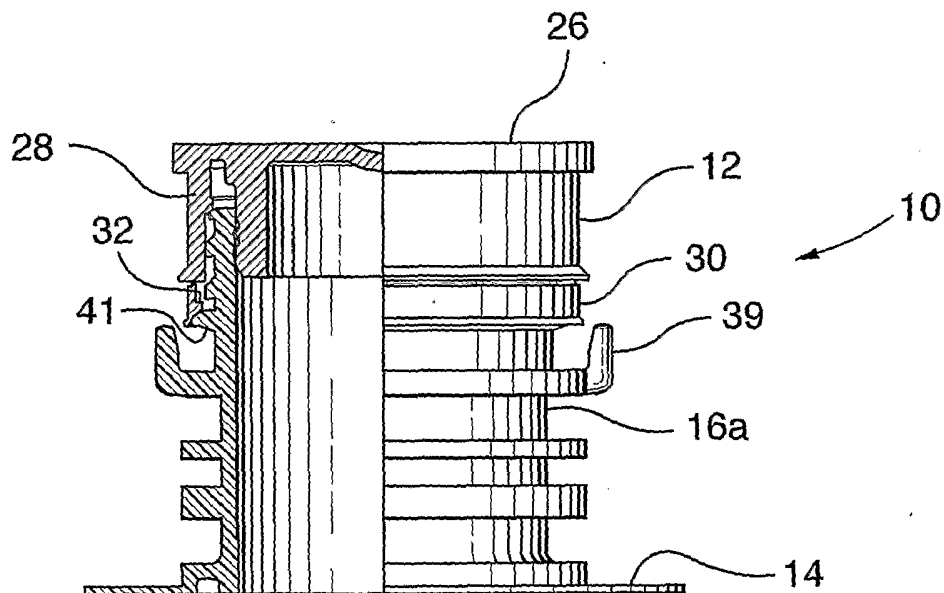

FIG.2B

5/7

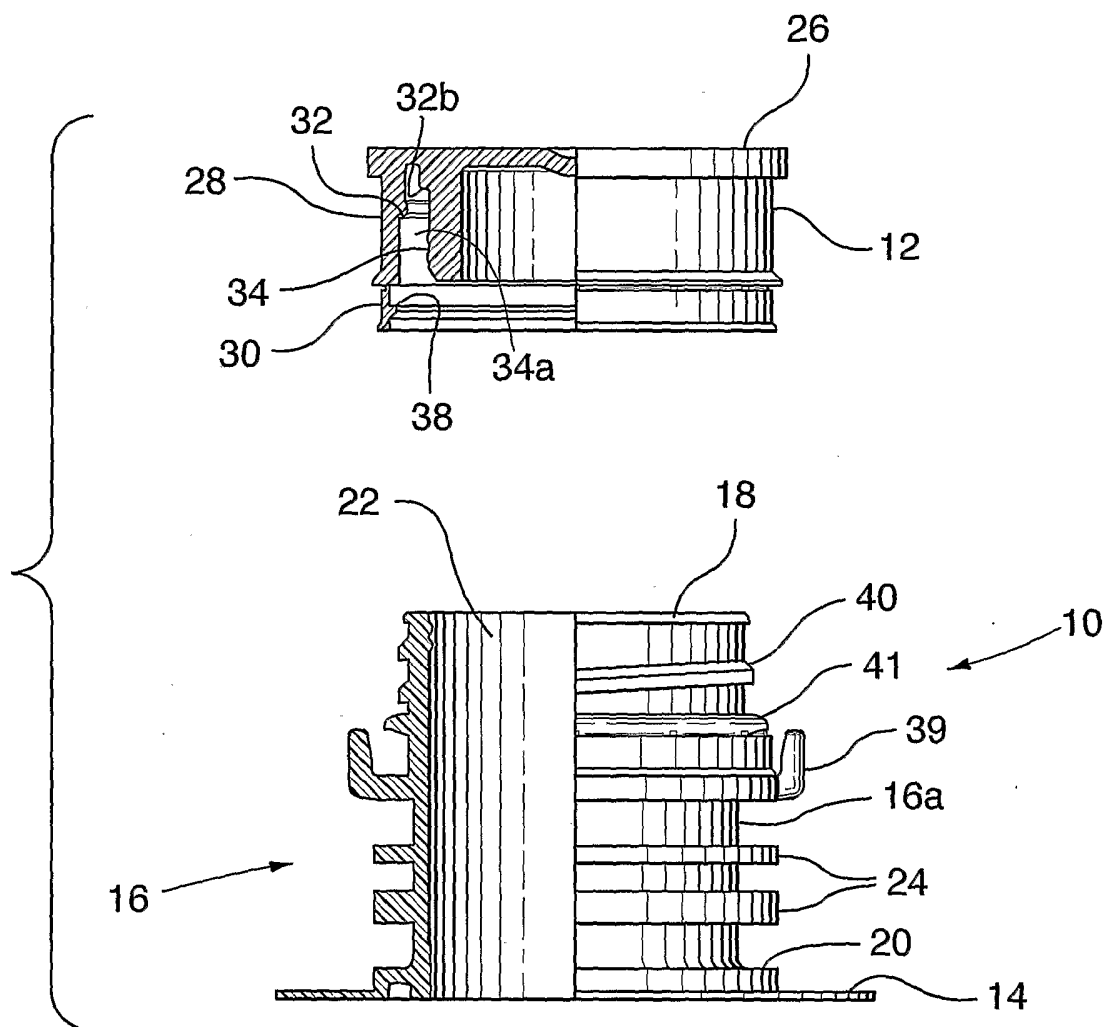

FIG.3

6/7

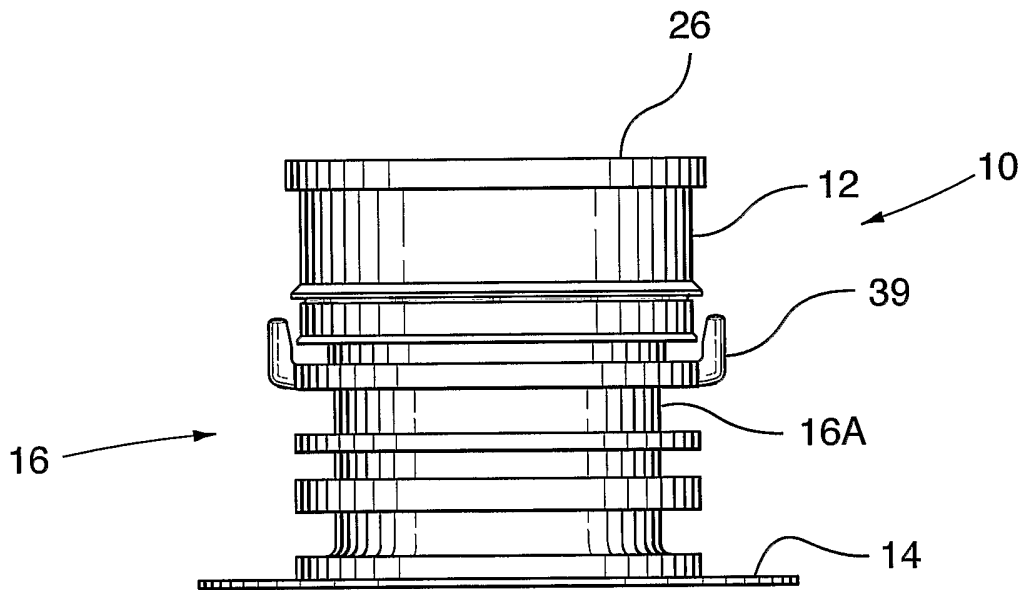

FIG. 4A

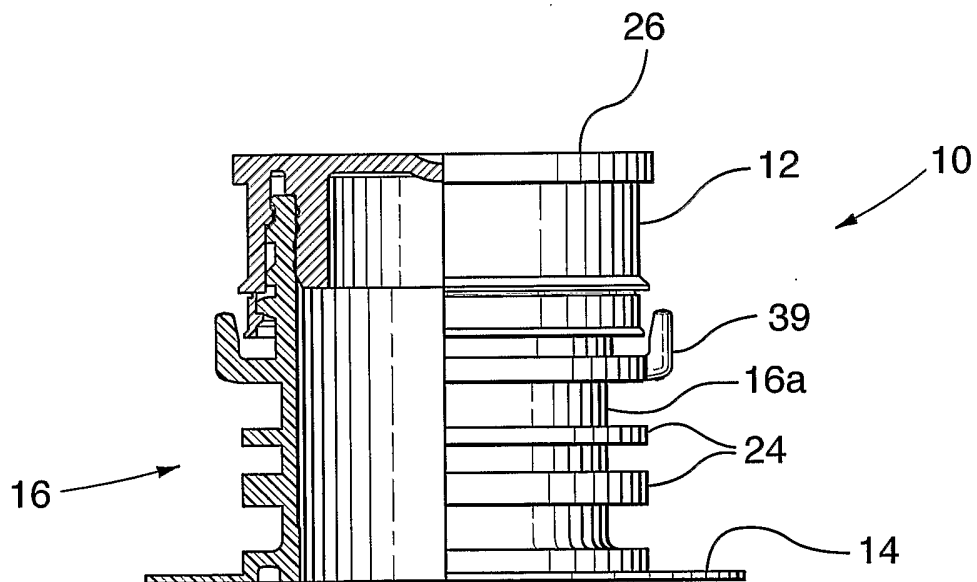

FIG. 4B

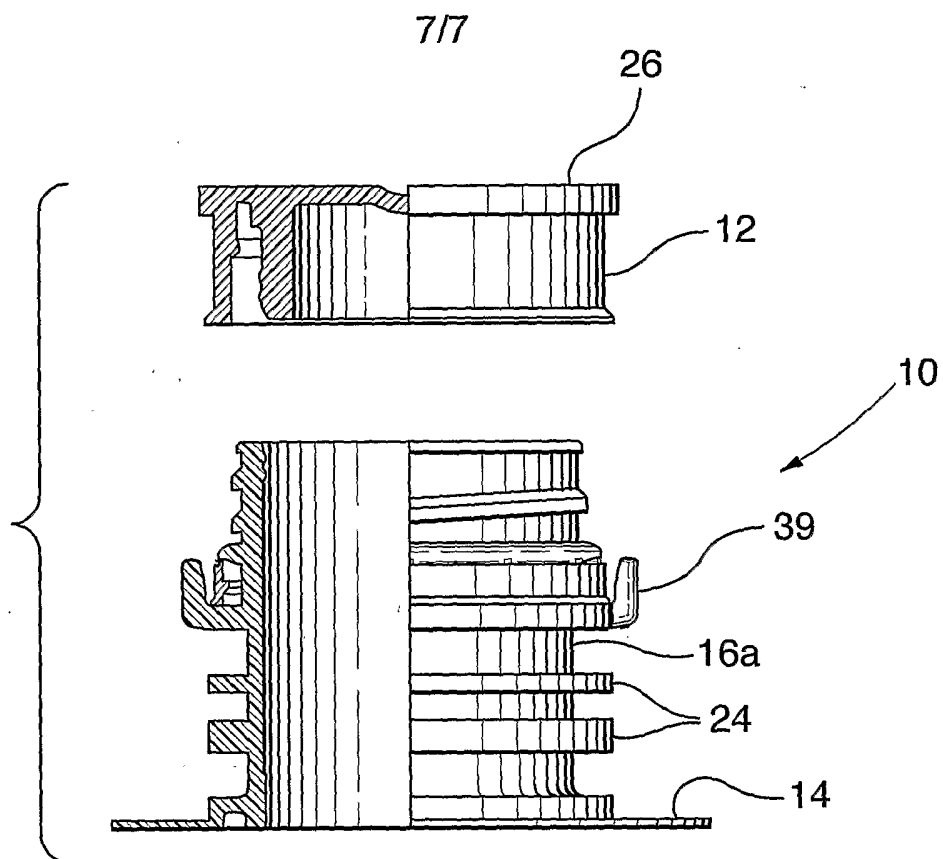

FIG. 5

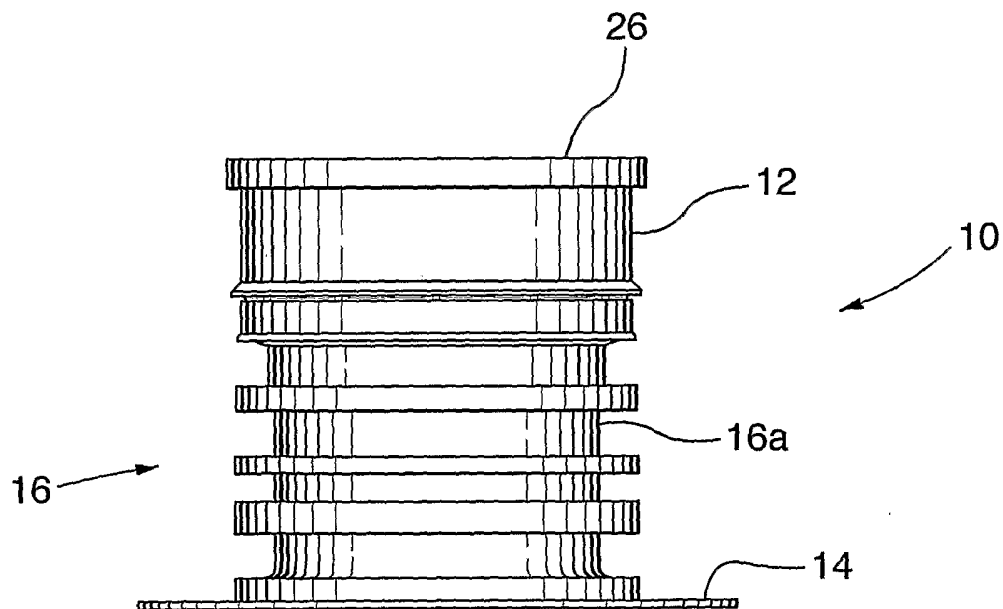

FIG. 6

INTERNATIONAL SEARCH REPORT

International application No.
PCT/CA2004/001436A. CLASSIFICATION OF SUBJECT MATTER
Int.Cl.⁷ B65D 55/02

According to International Patent Classification (IPC) or to both national classification and IPCB65

B. FIELDS SEARCHED

Minimum documentation searched (classification system followed by classification symbols)
Int.Cl.⁷ B65D41/00, 41/32, 41/34, 41/40-41/48, 47/02, 47/10, 47/12, 47/14, 47/20, 49/00-49/12, 50/00, 55/00-55/12, B67D3/00

Documentation searched other than minimum documentation to the extent that such documents are included in the fields searched

Electronic data base consulted during the international search (name of data base, and, where practicable, search terms used)
DELPHION, QPAT

C. DOCUMENTS CONSIDERED TO BE RELEVANT

Category*	Citation of document, with indication, where appropriate, of the relevant passages	Relevant to claim No.
Y	US 5,456,375 (Specialised Packaging Concepts Unit Trust) 10 October 1995 (10-08-1995) the entire document	2, 3
Y	US 5,303,837 (Portola Packaging, Inc.) 19 April 1994 (19-04-1994) column 3, line 57 to column 4, line 13	2
Y	US 4,445,550 (FranRica Mfg. Inc. et al.) 01 May 1984 (01-05-1984) column 3, lines 32 to 42; figure 3	3
A	US 4,371,089 (Internationale Verpakking Maatschappij BV) 01 February 1983 (01-02-1983)	1-5
A	US 5,009,323 (Sunbeam Plastics Corporation) 23 April 1991 (23-04-1991)	1-5
A	US 4,305,517 (Deniseal, Inc.) 15 December 1981 (15-12-1981)	1-5

Further documents are listed in the continuation of Box C.

Patent family members are listed in annex.

* Special categories of cited documents :	"T"	later document published after the international filing date or priority date and not in conflict with the application but cited to understand the principle or theory underlying the invention
"A" document defining the general state of the art which is not considered to be of particular relevance	"X"	document of particular relevance; the claimed invention cannot be considered novel or cannot be considered to involve an inventive step when the document is taken alone
"E" earlier application or patent but published on or after the international filing date	"Y"	document of particular relevance; the claimed invention cannot be considered to involve an inventive step when the document is combined with one or more other such documents, such combination being obvious to a person skilled in the art
"L" document which may throw doubts on priority claim(s) or which is cited to establish the publication date of another citation or other special reason (as specified)	"&"	document member of the same patent family
"O" document referring to an oral disclosure, use, exhibition or other means		
"P" document published prior to the international filing date but later than the priority date claimed		

Date of the actual completion of the international-type search
09 SEPTEMBER 2004 (09-09-2004)Date of mailing of the international-type search report
26 November 2004 (26-11-2004)Name and mailing address of the ISA/
Commissioner of Patents
Canadian Patent Office - PCT
Ottawa/Gatineau K1A 0C9
Facsimile No. 1-819-953-9358Authorized officer
Gregory Myslicki (819) 956-5824

INTERNATIONAL SEARCH REPORT
Information on patent family members

International application No.
PCT/CA2004/001436

Patent document cited in search report	Publication date	Patent family member(s)	Publication date
US5456375	10-10-1995	AT174567T T	15-01-1999
		AU686562 B2	12-02-1998
		AU710761 B2	30-09-1999
		AU4385493 A	13-12-1993
		AU5634998 A	07-05-1998
		CA2136320 A1	25-11-1993
		DE69322637D D1	28-01-1999
		DE69322637T T2	22-07-1999
		EP0640054 A1	01-03-1995
		JP8504151T T	07-05-1996
		US5456375 A	10-10-1995
		US5720402 A	24-02-1998
		WO9323304 A1	25-11-1993
		US5303837	19-04-1994
AT203483T T	15-08-2001		
AU653779 B2	13-10-1994		
AU664730 B2	30-11-1995		
AU666683 B2	22-02-1996		
AU1134092 A	10-09-1992		
AU2933392 A	21-05-1993		
AU3473893 A	03-08-1993		
AU3584593 A	03-09-1993		
BR9206669 A	02-05-1995		
BR9305765 A	28-01-1997		
CA2062008 A1	06-09-1992		
CA2121890 A1	29-04-1993		
CA2128526 A1	22-07-1993		
DE69230439D D1	20-01-2000		
DE69231954D D1	30-08-2001		
EP0502716 A2	09-09-1992		
EP0608378 A1	03-08-1994		
EP0621848 A1	02-11-1994		
IE920680 A1	09-09-1992		
JP5196141 A	06-08-1993		
JP7500304T T	12-01-1995		
JP7502955T T	30-03-1995		
MX9200986 A1	01-09-1992		
US5174465 A	29-12-1992		
US5249695 A	05-10-1993		
US5271519 A	21-12-1993		
US5303837 A	19-04-1994		
US5348182 A	20-09-1994		
US5348183 A	20-09-1994		
US5348184 A	20-09-1994		
US5397013 A	14-03-1995		
US5512228 A	30-04-1996		
US5597082 A	28-01-1997		
US5678719 A	21-10-1997		
WO9215496 A1	17-09-1992		
WO9308092 A1	29-04-1993		
WO9313998 A1	22-07-1993		
WO9314001 A1	22-07-1993		
WO9315970 A1	19-08-1993		
ZA9300103 A	10-08-1993		
ZA9300104 A	10-08-1993		

(Continuation of patent family annex)

Patent document cited in search report	Publication date	Patent family member(s)	Publication date		
US4445550	01-05-1984	AU1815983 A	23-02-1984		
		BR8304504 A	03-04-1984		
		CA1212652 A1	14-10-1986		
		EP0101613 A2	29-02-1984		
		ES282933U U	16-10-1985		
		GR79221 A1	22-10-1984		
		JP59084720 A	16-05-1984		
		US4445550 A	01-05-1984		
		ZA8306152 A	25-04-1984		
		US4371089	01-02-1983	AU548160 B2	28-11-1985
AU7432481 A	18-03-1982				
BE890215 A2	04-03-1982				
CA1166188 A1	24-04-1984				
CH652092 A5	31-10-1985				
DE3135331 A1	29-04-1982				
DK150138B B	15-12-1986				
ES269067U U	16-06-1983				
FI69031B B	30-08-1985				
FR2489784 A1	12-03-1982				
GB2084119 A	07-04-1982				
GR74354 A1	26-06-1984				
IE52053 B1	27-05-1987				
IT1138585 B	17-09-1986				
JP57077459 A	14-05-1982				
LU83601 A1	08-06-1983				
MX152824 A	17-06-1986				
NL181496C C	01-09-1987				
NO151783B B	25-02-1985				
PT73617 A	01-10-1981				
SE450567 B	06-07-1987				
SE8105026 A	09-03-1982				
US4371089 A	01-02-1983				
ZA8105702 A	25-08-1982				
US5009323	23-04-1991			CA2014709 A1	13-05-1991
				US5009323 A	23-04-1991
US4305517	15-12-1981			US4305517 A	15-12-1981