



INTERNATIONAL APPLICATION PUBLISHED UNDER THE PATENT COOPERATION TREATY (PCT)

<p>(51) International Patent Classification ³: A61M 1/03; F16K 11/10; F16L 55/14</p>	<p>A1</p>	<p>(11) International Publication Number: WO 81/02980 (43) International Publication Date: 29 October 1981 (29.10.81)</p>
<p>(21) International Application Number: PCT/US81/00335 (22) International Filing Date: 16 March 1981 (16.03.81) (31) Priority Application Number: 139,884 (32) Priority Date: 14 April 1980 (14.04.80) (33) Priority Country: US (71) Applicant: BAXTER TRAVENOL LABORATORIES, INC. [US/US]; One Baxter Parkway, Deerfield, IL 60015 (US). (72) Inventors: BILSTAD, Arnold, A.; 335 Pine, Deerfield, IL 60015 (US). BROWN, Richard, I.; 2335 Peachtree Lane, Northbrook, IL 60062 (US). (74) Agents: RYAN, Daniel, D. et al.; Baxter Travenol Laboratories, Inc., One Baxter Parkway, Deerfield, IL 60015 (US).</p>	<p>(81) Designated States: AU, BR, DE (European patent), FR (European patent), GB (European patent), JP. Published <i>With international search report</i></p>	

(54) Title: CONTROL SYSTEM FOR FLUID FLOW APPARATUS

(57) Abstract

A flow control system, for example for blood plasma or other medical fluids, comprises a plurality of flexible, collapsible flow conduits (16, 18, 20, 22) for the selective and aseptic transfer of fluids between various locations through said conduits. Switching means are provided for selectively collapsing a plurality of separate sections of the conduit to block fluid flow there-through, to selectively define specific and variable fluid flow paths in the flow conduit. In accordance with this invention, the switching means defines a cam plate (32), which in turn defines a generally flat face (35) positioned adjacent portions of the flow conduit. Pivot means (42) are provided causing the cam plate (32) to be rotatable about an axis normal to the flat face (35). Also, a cam connecting system (44, 46) is disclosed, to adapt it to pass through an openable door.

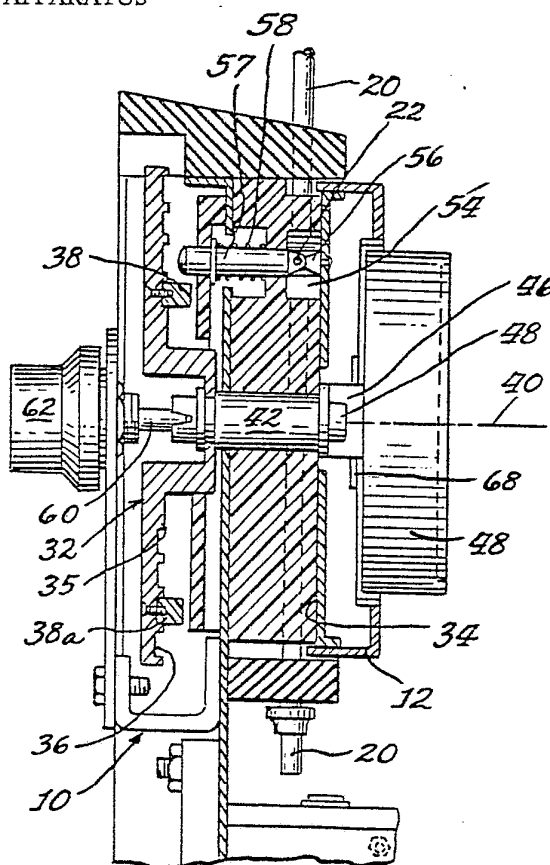

FOR THE PURPOSES OF INFORMATION ONLY

Codes used to identify States party to the PCT on the front pages of pamphlets publishing international applications under the PCT.

AT	Austria	KP	Democratic People's Republic of Korea
AU	Australia	LI	Liechtenstein
BR	Brazil	LU	Luxembourg
CF	Central African Republic	MC	Monaco
CG	Congo	MG	Madagascar
CH	Switzerland	MW	Malawi
CM	Cameroon	NL	Netherlands
DE	Germany, Federal Republic of	NO	Norway
DK	Denmark	RO	Romania
FI	Finland	SE	Sweden
FR	France	SN	Senegal
GA	Gabon	SU	Soviet Union
GB	United Kingdom	TD	Chad
HU	Hungary	TG	Togo
JP	Japan	US	United States of America

CONTROL SYSTEM FOR FLUID FLOW APPARATUS

Background of the Invention

5 This application relates to a simple manual control system, for providing control to a fluid flow apparatus which typically performs a relatively complex series of fluid switching functions through multiple flow paths. Additionally, the control system of this invention can simultaneously control the electrical functions of the same apparatus, in correlation with the fluid flow functions, from a single control knob.

10 The requirements of greater efficiency and cost reduction throughout all of technology, and specifically in the medical field, are resulting in the development of the relatively automated apparatus such as for the processing of blood or blood components, or for analysis of medical or other fluids. Such apparatus may be used in hemodialysis, blood oxygenation, or blood collection and component separation, including plasmapheresis.

15 In Sikula Patent No. 2,986,168, a control valve is shown for controlling fluid flow through a pair of valving elements as disposed in a single body.

In Gates Patent No. 1,427,455, cam operated valves control multiple flexible flow passages by compressing them to close, and by releasing them to open.

25 Bloch Patent No. 1,690,767 discloses another type of delivery valve in which cams on a rotatable member open and close a pair of valves.

30 However, a need remains for a control system which is capable of separately and independently controlling the flow from a single control member through multiple flow paths, while at the same time optionally providing correlated electrical controls. Furthermore,



in accordance with this invention, a control member may be mounted on a door or other separable member of the apparatus, with means being provided so that the connection of the control knob to the controlled elements may
5 be disconnected and reconnected in a manner which does not permit disruption of the correlation of the position of the control knob with the controlled elements.

Description of the Invention

In accordance with this invention, switching
10 means are provided for a flow system comprising a plurality of flexible, collapsible flow conduits for the selective transfer of fluid through the conduit. The switching means is adapted for selectively collapsing a plurality of separate sections of the conduit to block fluid flow
15 through them, for the purpose of selectively defining specific variable fluid flow paths in the flow conduits.

In accordance with this invention, the switching means defines a cam plate defining a generally flat face, positioned adjacent portions of the flow conduits. Pivot
20 means are provided, causing the cam plate to be rotatable about an axis normal to the flat face. Cam members are carried on the flat face, with the cam members preferably defining differing radii from the axis, for the purpose of permitting separate and independent control of a plurality of flow conduits.
25

The cam members are positioned to cause the pressurized collapse of a portion of the flow conduits, to block fluid flow through such portion when the cam plate is in one rotational position, and to be disengaged in
30 another rotational position from the pressurized, collapsed relation caused by the cam member, to permit flow through the portion when the cam plate is in the other rotational



position.

Accordingly, by this invention, a versatile, independent control of a plurality of flow conduits is provided. Multiple cam members may be placed at the
5 same radii from the axis, if it is desired to close and open a specific flow conduit more than once during a process cycle, with the cycle control being typically governed by a single 360° rotation of the cam plate. Accordingly, any desired pattern of flow modes may be
10 defined in the plurality of flow conduits as the cam plate is rotated about its axis.

Preferably, the cam members are arcuate in shape, each cam member defining a generally constant radius about the axis. Also, the flexible, collapsible flow conduits
15 are typically positioned in interconnecting relation with a plurality of containers, and may also include conduit means for communicating with the venous system of a blood donor, for example, to provide a blood processing apparatus such as plasmapheresis apparatus, having multi-
20 ple phases or cycles of operation as defined by the position of the cam plate.

Shaft means typically connect the cam plate with a control knob, with the shaft means optionally defining a pair of separable members to permit mechanical connection and disconnection of the cam plate and control knob
25 by separation of the separable members. The separable members define shaped, mating portions at facing ends, permitting the connection of the shaft means by joining of the separable members only when the separable members
30 occupy one specific relative rotational position. Accordingly, reconnection of the shaft means for operation of the control means is not possible unless the control knob is in proper rotational orientation with respect to the cam plate. Indicia may be placed in association with the
35 control knob to show the mode of operation that the



system is currently in.

The shaft means may also connect with and operate rotary switch means, which may constitute a control for an electrical system utilized in the device. Accordingly, the electrical functions controlled by the rotary switch means, the fluid flow functions controlled by the cam plate, and the rotational position of the control knob are all correlated on the shaft means when it is in the connected position.

The separable members of the shaft are typically utilized by placing one of the separable members and the control knob on a door member, which is hingedly attached to a housing for the remainder of the flow system. Thus, the door member may be opened, resulting in disconnection between the cam plate and the control knob, for access to the interior of the device, particularly the flexible conduits, which may be intended for one time use. When the device has been properly loaded and ready for operation, the door member may be closed, which can only take place through connection of the shaped, mating portions of the separable members when in proper relative rotational position, indicating proper rotational correlation of the cam plate and control knob.

In the drawings, Figure 1 is an elevational view, with portions broken away, of a control switch assembly for a flow system in an electrically operated plasmapheresis apparatus.

Figure 2 is a sectional view taken along line 2-2 of Figure 1.

Figure 3 is a perspective view of the apparatus of Figure 1 showing its interior, with the door member in open position.

Figure 4 is a truth table, illustrating the positions of closure valves of Figures 1 and 2 during the six modes of operation of the specific plasmapheresis

device.

Figure 5 is a fragmentary, perspective view of a cam plate used in this invention, illustrating how the arcuate cam members may be attached to the cam plate to define arcs of generally constant radius about the axis of rotation.

Figure 6 is a fragmentary, enlarged longitudinal sectional view of a portion of Figure 2, showing a valve assembly in a position closing flow through a flexible, collapsible flow conduit.

Figure 7 is a fragmentary, elevational view showing a portion of the front face of the door assembly in closed position, and showing the control knob carried by said donor assembly.

Referring to the drawings, a flow control system is disclosed which may be utilized as part of any apparatus for controlling fluid flow, and including correlated control means for an electrical system for the same apparatus. Specifically, the flow control system disclosed may be utilized as part of a plasmapheresis apparatus as described in the application of Richard I. Brown, et al. filed concurrently herewith and entitled "Blood Fractionation Apparatus".

Housing 10 may carry the flow control apparatus of this invention. Door member 12 is attached by hinges 14 to housing 10.

A plurality of flexible, collapsible flow conduits 16, 18, 20 and 22 are shown to be positioned in corresponding slots 24, 26, 28 for receiving the respective flexible, collapsible flow conduits. The flow conduits may be part of a disposable set or sets for the handling of blood plasma and saline solution during the operation of the plasmapheresis device.

For example, flexible conduit 16 may communicate at the top with a first source of saline parenteral

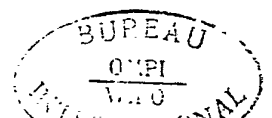

solution, and at the bottom with the remainder of the flow circuits of the plasmapheresis apparatus.

Flexible conduit 18 may communicate at its top with a second source of saline parenteral solution, and
5 at the bottom with the remainder of the flow circuits.

Flow conduit 20 may communicate at its top with an empty container for collecting plasma extracted from whole blood by the plasmapheresis device, and at its bottom communicating with an enlarged, flexible chamber,
10 as part of a disposable set which fits into a blood detection device, and which also connects with the remainder of the flow conduits.

Conduit 22 communicates at one end with conduit 20 through Y-connection chamber 30, as part of the disposable set, and leads at its other end to a bypass plasma line for returning plasma to the donor.
15

Other flexible disposable flow lines in the specific plasmapheresis set are not directly governed by the switching mechanism of this invention, as described
20 in the patent application cited above.

In accordance with this invention, switching means are provided including a cam plate 32, positioned behind wall 34 of housing 10. Cam plate 32 defines a generally flat face 35 which, in turn, may define a series
25 of concentric, annular grooves 36 for receiving separate, preferably generally arcuate cam members 38, 38a positioned in grooves 36, to define arcs of generally constant radius of about the axis of rotation 40 of the cam plate.

The pivoting means of cam plate 32 is provided
30 by rotatable shaft means 42. Shaft means 42 defines a pair of separable members 44, 46, to permit mechanical connection and disconnection of the cam plate and control knob 48.

As shown in Figure 3, separate members 44, 46
35 define at their facing ends, shaped, mating portions 48,

- 7 -

50, permitting the connection of shaft means 42 by joining of the separable members 44, 46 only when the separable members occupy one specific relative rotational position.

For example, as shown in Figure 3, shaped mating portion 50 defines a generally V-shaped groove, while mating portion 48 is a projection from the end of member 44 shaped to fit within the V-shaped groove 50. Accordingly, only when separable members 44, 46 of shaft 42 are in their relative rotational positions as shown in Figure 3 can they enter into the engaged relationship shown in Figure 2, with door member 12 being closed.

Accordingly, it becomes possible in accordance with this invention to open door member 12, thus separating the separable members 44, 46. Flexible conduits may be installed, replaced, or adjusted, and when operation of the apparatus is desired, the door member 12 may be closed again. If control knob 48 is in its proper rotational position relative to cam plate 32, members 44, 46 will interengage, and the door 12 can be successfully closed. Otherwise, the members 44, 46 cannot interengage, and the door cannot be closed.

Accordingly, in all circumstances when door 12 is closed, the indicia 52, associated with knob 48 and indicating the mode of operation that the flow control system is imposing, will always be correct relative to cam plate 32.

As cam plate 32 occupies differing rotational positions, cams 38, which are attached in predetermined positions within grooves 36 of cam plate 32, occupy differing radii from the axis of rotation 40, depending upon the specific annular groove 36 that they occupy. Two separate cams 38, 38a are shown in Figure 2 to occupy differing radii from axis 40.

As shown in Figures 1 and 3, apertures 54 are provided in wall 34 of housing 10. Anvil members 56 are positioned on the inside of door member 12 so that



they project to a position immediately adjacent apertures 54. Flexible conduits 16, 18, 20, 22 each project across an aperture 54 and an anvil 56 positioned in or immediately adjacent a corresponding aperture 54.

5 It can be seen that the points where each flexible conduit crosses an aperture 54 is positioned at a different radius from rotational axis 40 so that each cam or cams 38, as the case may be, occupying a particular annular groove 36, interacts only with a single one of
10 conduits 16, 18, 20 or 22. As shown in Figure 6, cam 38a for example, at the proper rotational position of cam plate 32, engages plunger 57 to, in the specific instance of Figure 6, depress it and squeeze conduit 22 into a closed, flow-blocking position. Corresponding plungers
15 are provided to pass through the other apertures 54 to compress the respective conduits 16, 18, 20 against an anvil 56, when impelled by a cam 38 rotated into engaging relation by cam plate 32.

20 However, as shown in Figure 2, when plunger 57 is not engaged by cam 38a, due to a different rotational position of cam plate 32, it is retracted by spring 58 to allow conduit 22 to open, with similar structure and function being utilized in the other plungers 56 as well.

25 Figure 4 illustrates a truth table which shows a typical mode of valving operation in the six different valving modes provided in the specific embodiment of the flow control system of this invention. The six modes are as indicated on knob 48, with the system being shown in the "load" mode in Figure 7.

30 Turning to the truth table of Figure 4, the symbol "0" indicates an open position and "1" indicates a closed position. It can be seen that in this rotational position of knob 48 and cam plate 32 all of the valves are open, with each plunger 56 being in its retracted
35 position, permitting flow through all of the tubes 16, 18, 20 and 22.

- 9 -

In the next mode, which involves the priming of the apparatus, a cam 38 moves into engagement with the plunger 57 which controls flow through flexible conduit 20 to close flow through that line.

5 In the next or bypass mode, cam plate 32 rotates to close conduits 16 and 18, while conduit 20 remains closed.

10 In the next or "collect" mode, the cam plate 32 is rotated to bring cams 38 into engagement with plungers 57 to close off the conduit 22, while conduit 20 is opened for collecting the plasma in a sterile container. Conduits 16 and 18 remain closed.

15 Following this, in the "irrigate mode", cam plate 32 is rotated to close conduits 20 and 22, while the saline source conduits 16, 18 are opened.

Finally, in the "reinfuse" mode, cam plate 32 is rotated to close only conduit 20, so that a flow path leads through conduit 22 for reinfusion of plasma to the donor.

20 Shaft member 42 communicates as shown in Figure 2 with shaft extension 60, with a connection which does not permit relative rotation between extension 60 and the rest of shaft 42. Shaft extension 60, in turn, communicates with rotary switch 62, of conventional design, to provide appropriate multiple switching modes to the electrical components of the plasmapheresis device in a manner which correlates with the rotational position of cam plate 32 and knob 48. Accordingly, the necessary electrical functions involving the starting and stopping of roller pumps to impel liquids through the flexible conduits, and the like, is coordinated with the operation of cams 38 in opening and closing flow through flexible conduits 16, 18, 20 and 22, for correlated operation of the various components of the plasmapheresis apparatus through one manual control, which is operated by the user by the manipulation of knob 48. Rotary switch 62 may be connected to any desired number of leads which, in turn, connect

25
30
35



to the electrically operated parts of the plasmapheresis device.

Door 12 is selectively latched so that it can only open in the "load" mode as indicated by knob 48, as follows. Projection 64, carried by wall 34 of housing 10, defines a latching groove 66 about at least a portion of its periphery.

Positioned on separable member 46 of shaft 42, behind knob 48, is disc member 68, defining a generally circular periphery 70 about the majority of its periphery, and further defining a cutaway portion 72 at one portion of its periphery. When door member 12 is closed, and knob 48 is positioned in a mode other than "load", for example, the periphery 70 of disc member 68 engages locking groove 66, thus preventing opening of the door. However, when knob member 48 is in the "load" mode, cutaway portion 72 is positioned adjacent projecting member 64 so that there is no engagement of disc 68 in groove 66, and the door is unlatched for opening.

Added manual safety latch 72 is also provided to hold door 12 in locked position.

Accordingly, a flow control system in accordance with this invention is provided which permits complex and multiple valving functions throughout a plurality of flow modes, while at the same time providing simultaneous, correlated electrical switching for operation of the electrical components of a system. Similarly, the control knob for this system may be mounted on a door so as to be separable from the remainder of the system, but may be reliably brought back into connection upon closing of the door without rotational misalignment of the control knob.

The above has been offered for illustrative purposes only, and is not intended to limit the invention of this application, which is as defined in the claims below.



THAT WHICH IS CLAIMED IS:

1. In a flow control system comprising a plurality of flexible, collapsible flow conduits for the selective transfer of fluids through said conduits, and switching means for selectively collapsing a plurality of separate sections of the conduits, to block fluid flow therethrough, to selectively define specific and variable fluid flow paths in the flow conduits, the improvement comprising, in combination:
- 5
- 10 said switching means defining a cam plate defining a generally flat face positioned adjacent portions of the flow conduits; pivot means causing said cam plate to be rotatable about an axis normal to said flat face; cam members carried on said flat face, said cam members defining differing radii from said axis, said cam members being positioned to cause the pressurized collapse of portions of said flow conduits, to independently block fluid flow through each portion when said cam plate is in one particular rotational position and to be disengaged from said pressurized, collapsed relation caused by said cam member to permit flow through said portion when the
- 15
- 20 cam plate is in another particular rotational position.



2. In a flow control system comprising a plurality of flexible, collapsible flow conduits for the selective transfer of fluids through said conduits, and switching means for selectively collapsing a plurality of separate sections of said conduits to block fluid flow therethrough, to selectively define specific and variable fluid flow paths in said flow conduits, the improvement comprising, in combination:

said switching means defining a cam plate defining a generally flat face positioned adjacent portions of said flow conduits; pivot means causing said cam plate to be rotatable about an axis normal to said flat face; and arcuate cam members carried on said flat face, said arcuate cam members being each positioned to define arcs of generally constant radius about said axis, separate cam members defining different radii from said axis; a plurality of spaced, stationary plunger means, each positioned to be engaged by an arcuate cam member and to be pressed against a portion of one of said flow conduits to block fluid flow through said portion when said cam plate is in one rotational position, and to be disengaged from said cam member to permit flow through said portion when said cam plate is in another rotational position.

3. The flow control system of Claim 2 in which said flexible, collapsible flow conduits are positioned in interconnecting relation with a plurality of containers, and also include conduit means for communicating with the venous system of a blood donor.



4. The flow control system of Claim 3 in which shaft means connects said cam plate with a control knob, said shaft means defining a pair of separable members to permit mechanical connection and disconnection of said cam plate and control knob by separation of said separable members, said separable members defining shaped, mating portions permitting the connection of said shaft means by joining of said separable members only when the separable members occupy one specific relative rotational position.

5. The flow control system of Claim 4 in which said shaft means also connects with and operates rotary switch means, whereby the electrical functions controlled by said rotary switch means, the fluid flow functions controlled by the cam plate, and the rotational position of said control knob are all correlated on said shaft in the connected position.

6. The flow control system of Claim 5 which is part of plasmapheresis apparatus.

7. The flow control system of Claim 6 in which one of said separable members and the control knob is carried on a door member hingedly attached to the remainder of said flow system.



8. In a flow system comprising a plurality of flexible, collapsible flow conduits for the selective transfer of fluids through said conduits, and switching means for selectively collapsing a plurality of separate sections of the conduit to block fluid flow therethrough, to selectively define specific and variable fluid flow paths in the flow conduits, the improvement comprising, in combination:

5
10
15
20
25

said switching means defining a cam member positioned adjacent portions of the flow conduit, pivot means causing said cam member to be rotated about an axis; said cam member being positioned to cause the pressurized collapse of a portion of said flow conduits to block fluid flow through said portion in one rotational position and to be disengaged from said relation in another rotational position to permit fluid flow through said portion of the flow conduit; shaft means connecting said cam member with a control knob, said shaft means defining a pair of separable members to permit mechanical connection and disconnection of said cam member and control knob by separation of said separable members, said separable members defining shaped, mating portions permitting the connection of said shaft means by joining said separable members only when the separable members occupy one specific relative rotational position.

9. The flow system of Claim 8 which includes an electrical system for exercising various functions in correlation with the fluid flow functions of the collapsible flow conduits, said shaft means also connecting with
5 and controlling rotary switch means for controlling said electrical system, whereby the electrical functions controlled by said rotary switch means, the fluid flow functions of the collapsible flow conduit controlled by
10 the cam member, and the rotational position of said control knob are correlated on said shaft in the connected position.

10. The flow system of Claim 9 in which said flow system is carried in a housing having a door member hingedly attached to said housing, one of said separable
15 members and the control knob being carried on said door member, and the other of said separable members being carried within said housing.

11. The flow system of Claim 10 in which said flexible, collapsible flow conduits are position in inter-
20 connecting relation with the plurality of containers, and also include conduit means for communicating with the venous system of a blood donor.

12. The flow system of Claim 11 which is part of plasmapheresis apparatus.



13. The flow system of Claim 12 in which said control knob is associated with indicia indicating the status of the operating mode created in said flow system by the respective positions of said cam member and rotary switch.

14. The flow system of Claim 10 in which said cam member defines a flat piece positioned adjacent portions of said flow conduits, and arcuate cam members carried on said flat face, said arcuate cam members being each positioned to define arcs of generally constant radius about their axis of rotation, separate cam members defining different radii from said axis; a plurality of spaced, stationary plunger means, each positioned to be engaged by an arcuate cam member and to be pressed against a portion of one of said flow conduits to block fluid flow through said portion when said cam member is in one rotational position, and to be disengaged from said cam member to permit flow through said portions when said cam plate is another rotational position.

15. The flow system of Claim 14 in which the shaped, mating portions of said separable members respectively comprise slot means transversely positioned on the end of one of said separable members; said slot means defining walls of generally V-shape, and a projection positioned on the facing end of the other of said separable members of a shape complimentary to said slot and adapted to fit therein.

- 17 -

Claim 16. The flow system of Claim 10 in which
said door member defines latch means which comprises a
stationary locking member defining an overhanging flange
positioned within said housing, and a rotatable disc
5 positioned on and rotatable with said separable member
carried by the door member, the periphery of said disc
being adapted to fit into said slot means of the sta-
tionary locking member to hold said door in closed posi-
tion, and a cutaway portion in the periphery of said disc
10 adapted to permit disconnection of said disc from the
stationary locking means in a predetermined rotational
position of said separable member carried by the door
member.

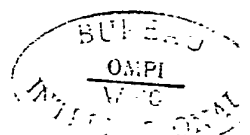

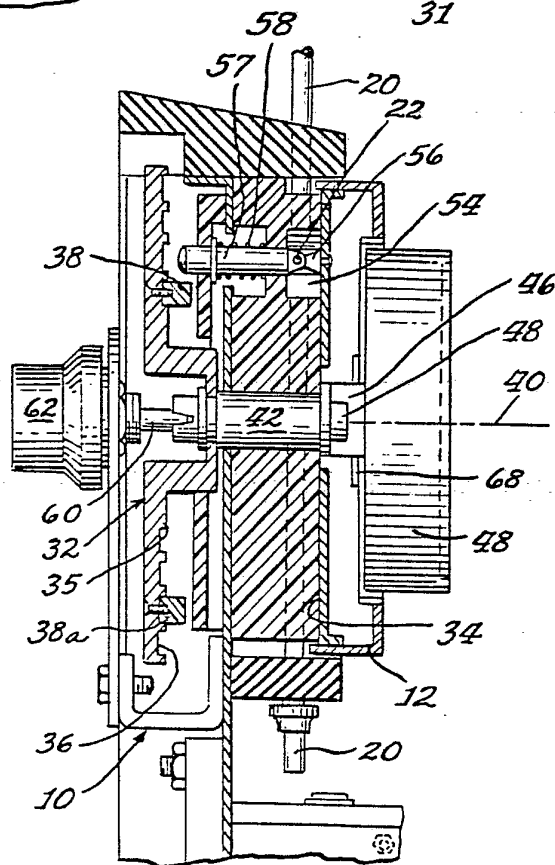
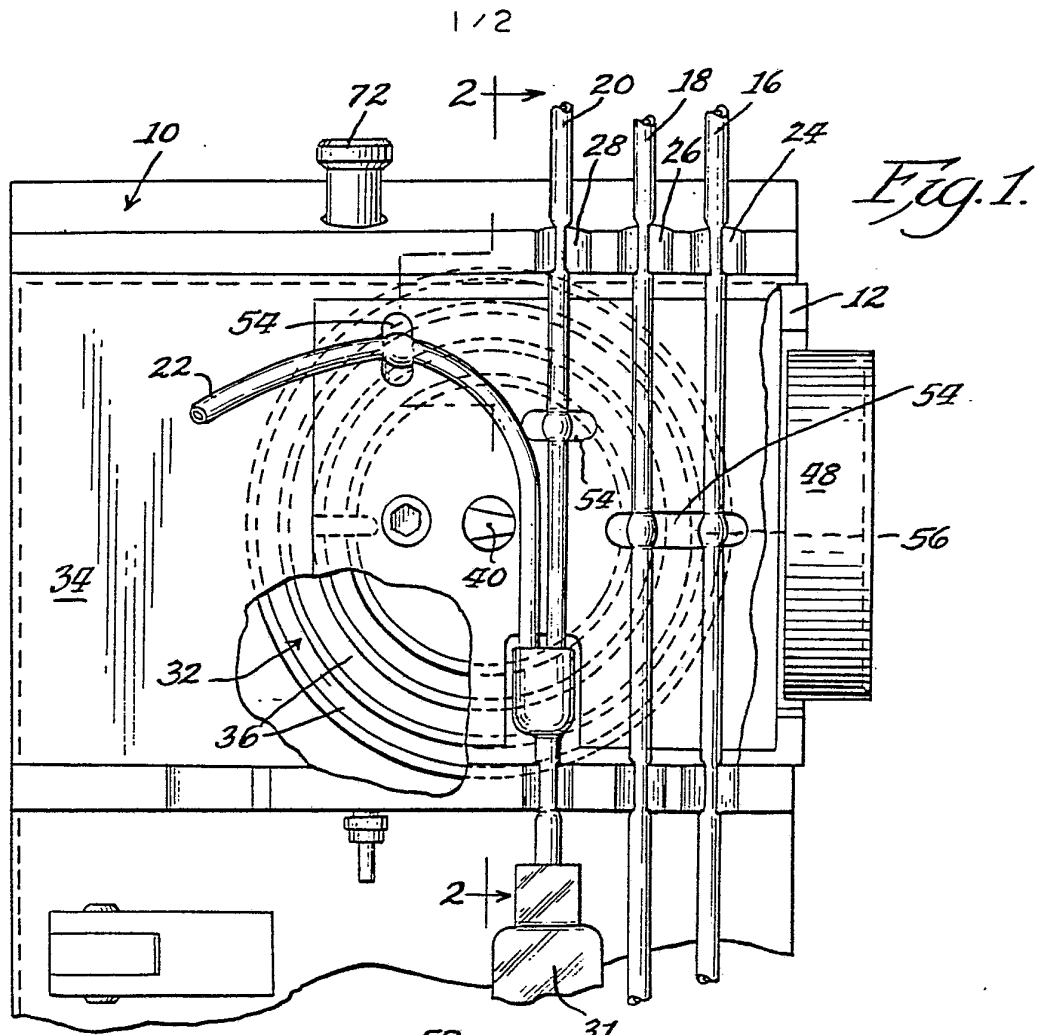

212

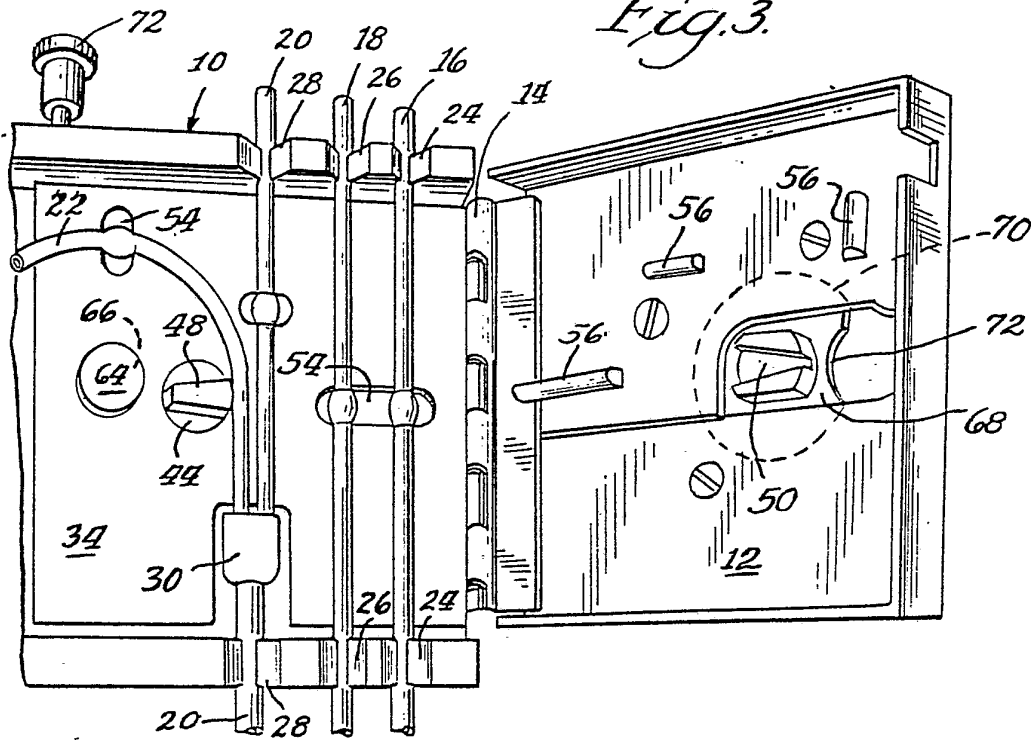

TUBE	(16)	(18)	(22)	(20)
POSITION	SALINE 1	SALINE 2	BYPASS	COLLECT
LOAD	0	0	0	0
PRIME	0	0	0	1
BYPASS	1	1	0	1
COLLECT	1	1	1	0
IRRIGATE	0	0	1	1
REINFUSE	0	0	0	1

Fig. 4.

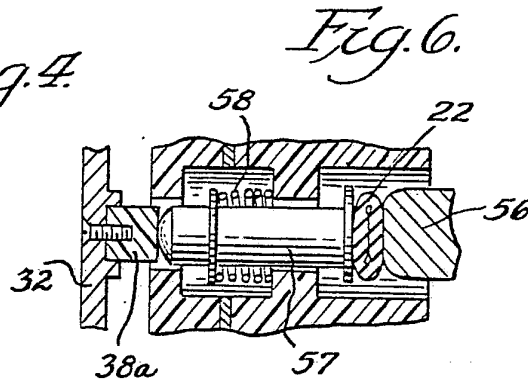

Fig. 6.

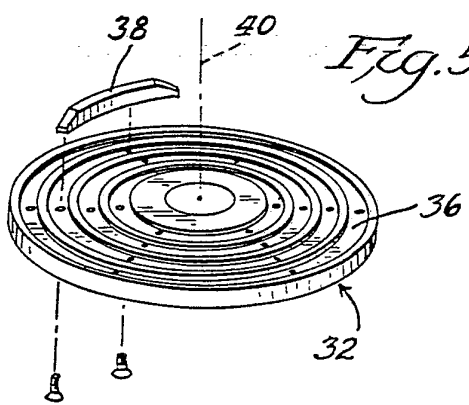

Fig. 5.

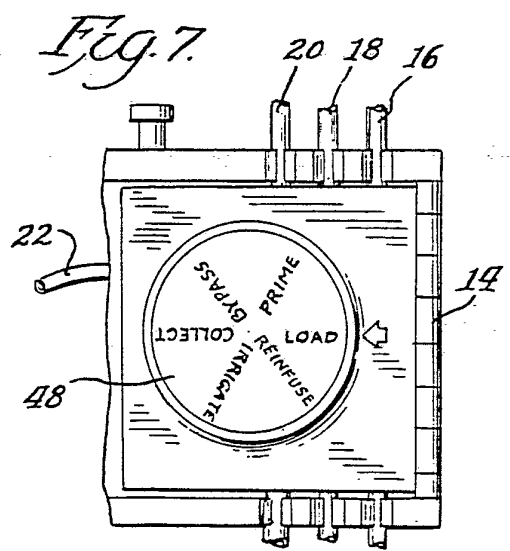

Fig. 7.

INTERNATIONAL SEARCH REPORT

International Application No PCT/US81/00335

I. CLASSIFICATION OF SUBJECT MATTER (if several classification symbols apply, indicate all) ³				
According to International Patent Classification (IPC) or to both National Classification and IPC				
INT. CL.3 A61M 1/03; F16K 11/10; F16L 55/14				
U.S. CL. 128/214R; 137/595; 251/7				
II. FIELDS SEARCHED				
Minimum Documentation Searched ⁴				
Classification System	Classification Symbols			
US	128/214R; 137/595,566; 74/568R 251/4,6,7,8,9; 222/214			
Documentation Searched other than Minimum Documentation to the extent that such Documents are included in the Fields Searched ⁵				
III. DOCUMENTS CONSIDERED TO BE RELEVANT ¹⁴				
Category ⁶	Citation of Document, ¹⁶ with indication, where appropriate, of the relevant passages ¹⁷	Relevant to Claim No. ¹⁸		
	US, A, 3,550,619 Published 29 December 1970 Halasaz, et al.	1-16		
	US, A, 868,322 Published 15 October 1907 Blum	1-7,14,15		
	DE, B, 2,700,491, Published 24 May 1978	1-7,14,15		
	US, A, 4,061,142, Published 06 December 1977 Tuttle	3,6,11,12		
	US, A, 2,298,890, Published 13 October 1942 Leonard	1-7,14,15		
A	US, A, 3,063,306, Published 13 November 1962	4,8		
A	US, A, 3,517,695, Published 30 June 1970 Eveleigh, et al	5,9		
A	US, A, 3,402,853, Published 24 September 1968 Perl	5,7,9,10		
A	US, A, 3,679,331, Published 25 July 1972 Kushner	1,2		
A	US, A, 3,411,534, Published 19 November 1968 Rose	8		
<p>¹⁵ Special categories of cited documents:</p> <table style="width: 100%; border: none;"> <tr> <td style="width: 50%; border: none; vertical-align: top;"> <p>"A" document defining the general state of the art</p> <p>"E" earlier document but published on or after the international filing date</p> <p>"L" document cited for special reason other than those referred to in the other categories</p> <p>"O" document referring to an oral disclosure, use, exhibition or other means</p> </td> <td style="width: 50%; border: none; vertical-align: top;"> <p>"P" document published prior to the international filing date but on or after the priority date claimed</p> <p>"T" later document published on or after the international filing date or priority date and not in conflict with the application, but cited to understand the principle or theory underlying the invention</p> <p>"X" document of particular relevance</p> </td> </tr> </table>			<p>"A" document defining the general state of the art</p> <p>"E" earlier document but published on or after the international filing date</p> <p>"L" document cited for special reason other than those referred to in the other categories</p> <p>"O" document referring to an oral disclosure, use, exhibition or other means</p>	<p>"P" document published prior to the international filing date but on or after the priority date claimed</p> <p>"T" later document published on or after the international filing date or priority date and not in conflict with the application, but cited to understand the principle or theory underlying the invention</p> <p>"X" document of particular relevance</p>
<p>"A" document defining the general state of the art</p> <p>"E" earlier document but published on or after the international filing date</p> <p>"L" document cited for special reason other than those referred to in the other categories</p> <p>"O" document referring to an oral disclosure, use, exhibition or other means</p>	<p>"P" document published prior to the international filing date but on or after the priority date claimed</p> <p>"T" later document published on or after the international filing date or priority date and not in conflict with the application, but cited to understand the principle or theory underlying the invention</p> <p>"X" document of particular relevance</p>			
IV. CERTIFICATION				
Date of the Actual Completion of the International Search ²	Date of Mailing of this International Search Report ³			
07 July 1981	21 JUL 1981			
International Searching Authority ¹	Signature of Authorized Officer ²⁰			
ISA/US	<i>Steven A. Brathie</i>			