

March 13, 1945.

B. BERGHAUS ET AL

2,371,278

ELECTRIC REACTION FURNACE

Filed Sept. 28, 1938

2 Sheets-Sheet 1

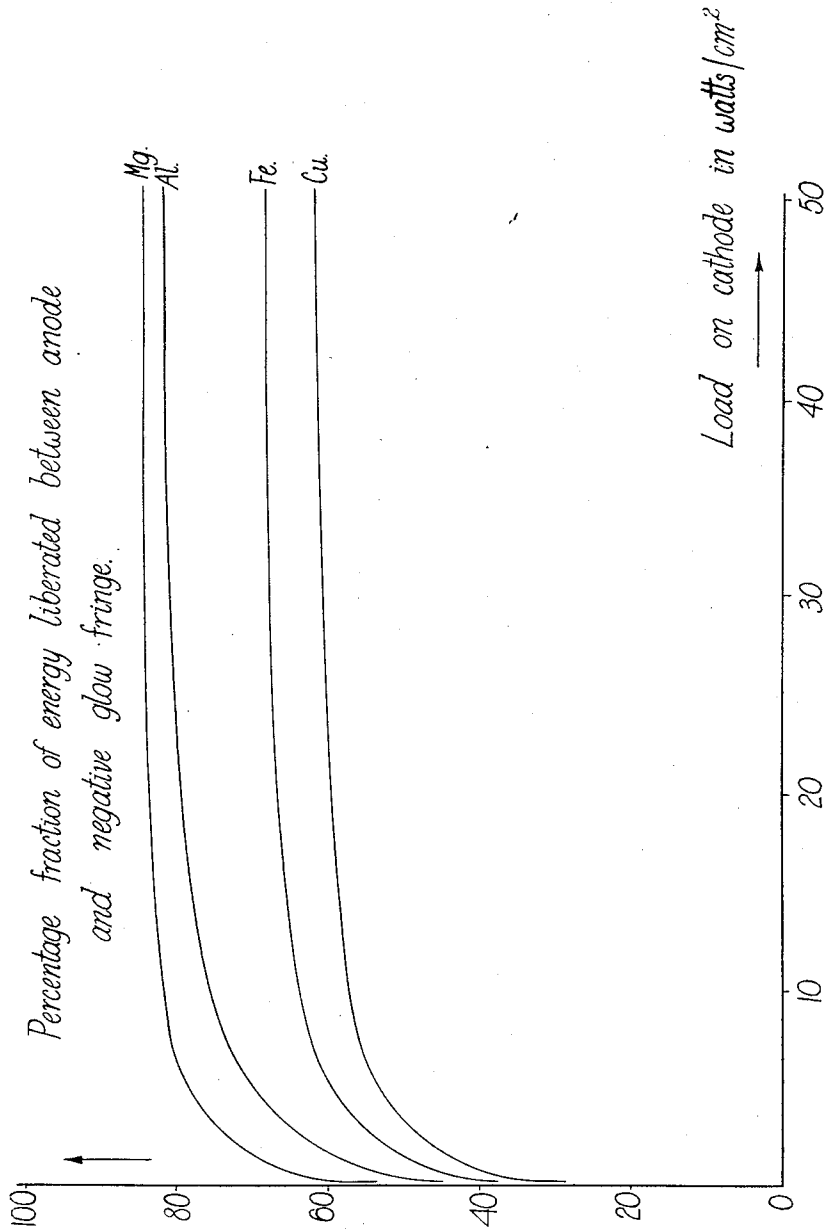

Fig. 1

B. Berghaus
W. Burkhardt
Inventors

By: *Glascop Downing Seibold*
Attys.

March 13, 1945.

B. BERGHAUS ET AL
ELECTRIC REACTION FURNACE

2,371,278

Filed Sept. 28, 1938

2 Sheets-Sheet 2

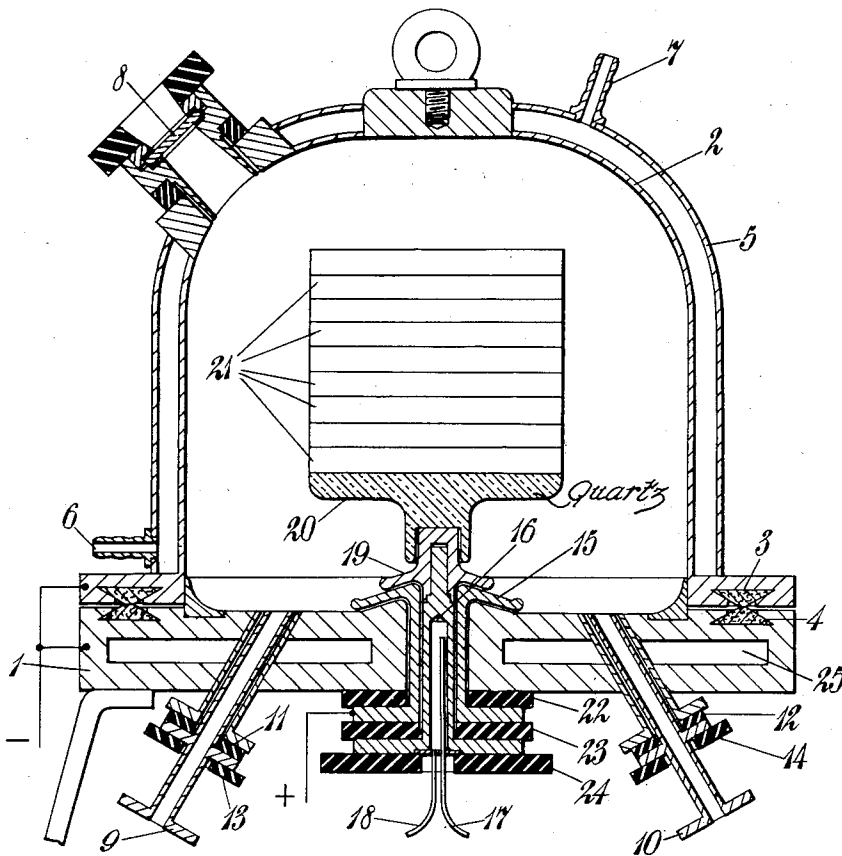

Fig. 2

B. Berghaus
W. Burkhardt
Inventors

By: *Glascod, Downing & Peck*
Attys.

UNITED STATES PATENT OFFICE

2,371,278

ELECTRIC REACTION FURNACE

Bernhard Berghaus, Berlin-Lankwitz, and Wilhelm Burkhardt, Berlin-Grünwald, Germany; vested in the Alien Property Custodian

Application September 28, 1938, Serial No. 232,237
In Germany January 25, 1938

1 Claim. (Cl. 219—35)

The present invention relates to an electrically heated vacuum annealing and fusion furnace or oven for metallic and non-metallic material which is distinguished by the fact that the wall of the oven or furnace is connected as a cathode with respect to an insulated introduced anode.

The material to be heated is arranged in the furnace electrically and thermally insulated. The material to be heated rests either on an insulating plate or in a crucible of quartz, glass, porcelain or other ceramic masses or on a plate or in a crucible of metal or graphite, which is carried by a coolable lead-through arrangement. Preferably the wall of the furnace connected as a cathode consists of metal, such as iron or steel or still better of light metal or a light metal alloy. The oven wall connected as a cathode is in the case of short-period annealings or fusions constructed so as to be coolable. The oven wall connected as a cathode may however also be surrounded with a heat-insulating material, particularly for lengthy annealings. The oven wall connected as a cathode may consist of an electric semi-conductor, such as graphite or slate. The material to be annealed or fused may be in conducting connection with the anode or may itself form the anode. The pressure in the oven or furnace chamber preferably amounts to 10 to 0.05 millimeters of mercury, the voltage on the furnace chamber amounting to about 500 up to 7000 volts. The current cover per square centimetre of surface of the cathodically connected furnace wall preferably amounts to 0.5 to 100 millimeters. It may assume still higher values for sintering or fusing purposes wherein temperatures up to 3000° C. are necessary. The insulated introduced lead-through element may be metallic and at the same time may be the current lead in for the anode, or, if the anode has a separate current lead, may consist wholly of insulating material, such as glass, quartz, ceramic masses, the insulated lead-through element is likewise cooled. The current lead in for the anode and the insulated introduced supports for the article or articles to be heated may advantageously be disposed concentrically.

For operating the furnace advantageously a direct voltage is used, the negative side being connected to the housing and the positive side to the anode; however, alternating voltage is also suitable if the effective surface of the introduced electrode is made very small with respect to the surface of the furnace housing, when a rectifying effect is produced. The current lead in for the

anode is surrounded at a small distance by the cathode. The space forms a ring gap and protects the insulating material arranged behind the same from the impact of charge carriers from the gas discharge, as well as from particles disintegrated off the cathode, and the heat radiation. The insulating material which is behind the ring gap partly represents a prolongation of the same. The distance of the metallic jacketing of the current lead in for the anode into the gas space is chosen smaller than the distance of the glow fringe around the cathode. In practical operation a space of 5 to 0.1 millimeters has proved to be sufficient and is essentially dependent upon the gas pressure and the voltage applied between the electrodes. It is advantageous to construct the gap in labyrinth form in order to prevent direct access of charge carriers from the discharge and disintegrated particles. In order to apply still higher voltages than 7000 volts the ring gap may be partly provided with an insulator, of quartz, glass, porcelain and so forth. The current lead in is hollow and cooled at its inner wall in order to protect the insulating means from heating.

The vacuum furnace described in more detail below depends upon a completely new method of converting electrical energy into heat, and the attenuated gas in the space between the glow fringe and the anode on applying a voltage serves as a resistance heating element which surrounds the material to be heated. For example, it has been found that the energy supplied to the gas or glow discharge when the "heating voltage" is equal to the cathode drop, is completely converted into heat at the cathode and consequently no appreciable heat is liberated in the space between the glow and the anode. If the "heating voltage" exceeds the cathode drop, there takes place a heating of the glow fringe anode space which increases with the difference between the two voltage values. It has been found that by increasing the power of the gas discharge the proportion between the "heating voltage" and cathode drop increases. It has further been found, as is apparent from mutual comparison of the curves in Figure 1, that the ratio of the "heating voltage" to the cathode drop is more favorable the more readily the cathode material emits electrons. Further experiments have shown in confirmation that for example still better values are produced by light metals oxidised from the start or light metals spontaneously oxidising during the operation.

It has also been found that the form of the gas space between the glow fringe and anode is important for the ratio of "heating voltage" and cathode drop, and in fact the ratio of the "heating voltage" to cathode drop increases the greater the fraction of the space between glow fringe and anode, which is occupied by the article.

If for example an article of metallic or non-metallic nature is introduced into this gas space then, corresponding to its size, the same assumes in certain time a maximum temperature which depends upon the energy applied. If the quantity of heat liberated at the cathode is not accumulated, but is continuously led away by means of cooling water, then for the heating of iron bodies of various sizes an economy for the furnace is obtained which increases with the size of the iron bodies.

In a furnace of 6 litres capacity iron articles of various sizes were introduced and heated to a temperature of for example 1000°. With copper as cathode material and hydrogen as filling gas, at a pressure of 0.2 millimeter of mercury an efficiency was obtained, in spite of the unfavourably chosen conditions, of 10% for 0.5 kg., 30% for 5.5 kg., and 40% for 11.5 kg.

The principle of the furnace or oven obviously depends upon the fact that the otherwise usual electric heating element in the form of wire spirals, silicon carbide rods or other materials is replaced by the attenuated gas. What has proved to be surprising in these experiments is that the energy distribution between the cathode and gas space increases with increasing watt load referred to the cathode surface as shown in Fig. 1, and that special cathode materials favour this distribution. The ratio of cathode drop to "heating voltage" is always greater the more space the body to be heated or the furnace charge takes up in the furnace. As the interior resistance of the remaining gas space increases, more energy remains for heating the material in the gas space between the glow fringe and the electrode by purely ohmic consideration.

In an experimental oven or furnace having a chamber of 6 litres the following values were for example ascertained as regards the interior resistance:

| Weight, kg. | Current | Voltage | Resistance |
|-------------|---------|---------|--------------------|
| 0.5 | 2.66 | 1,250 | <i>Ohms</i> 470 |
| 5.5 | 2.00 | 1,650 | 820 |
| 12.0 | 1.5 | 3,200 | 1,270 |

As the ratio of anomalous current to normal current on the cathode, values were obtained in the experiments up to 2000-fold. When the furnace casing formed the cathode, then with a ratio of 160-fold a 12 kg. body of iron could in one hour be heated to 1000° at a total energy of 7 kilowatts. However, heating to medium temperatures, for example 300 to 500°, could be obtained with far smaller values, or 30 to 80 times the normal current. The ratio of anomalous current to normal current consequently depends upon the temperature of the articles to be heated or on the time in which a definite temperature is to be attained.

Since a temperature of 1300° or more can conveniently be attained, tempering, letting down, clean annealing, hardening or the like can be carried out in the oven or furnace in a protective

gas atmosphere. The oven therefore offers the advantage that there is no oxidation or scaling or the surfaces of the work, which is a matter of importance, especially for molybdenum steels.

The oven or furnace also offers particular advantages for the fusion of readily oxidisable and highly melting metals, since it avoids oxidation by using an indifferent gas at subatmospheric pressures of about 1 millimeter of mercury and less and extensive degassing of the melt is brought about.

In the accompanying drawings the invention is shown in some detail in one structural example, Figure 2 showing a section through an electrically heated vacuum annealing and melting oven or furnace for metallic and non-metallic material, in which the wall of the oven is connected as a cathode of a glow discharge with respect to an insulated introduced anode, and in which the material to be annealed is arranged electrically insulated in the oven, and in which the electrically heated gas between the cathodic glow fringe and the anode forms the heating element for the material to be heated. The vacuum annealing and melting oven consists of a lower part 1 and a removable upper part 2, which are connected together in vacuum-tight fashion by means of seals 3 and 4, and which individually or jointly form the cathode. The upper part 2, constructed for example in the form of a hood, is provided with a cooling jacket 5 to which a cooling medium may be supplied through the tube 6, which medium can be led off through the outlet 7. In the upper part an opening is also provided which is closed by means of a viewing window 8. The insulated pipe connection 9 arranged in the lower part is connected to a vacuum pump (not shown) by means of which preferably a pressure of 10.0 to 0.05 millimeters of mercury can be adjusted. The lower part 1 also possesses a pipe connection 10, likewise insulated with respect to the cathode. The parts 11 and 12 are insulating rings and the parts 13 and 14 are insulating and pressing-on rings. A pressure indicating appliance may be attached to the pipe connection 10, and through this connection 10 there may also be supplied a filling gas in regulated quantity by way of a regulating valve, not shown. According to the material being heated or annealed, the inert filling gas used may be argon, krypton, xenon, helium, or a reducing gas, such as hydrogen, hydrocarbons or the like. Nitrogen, ammonia or similar gases may also be employed if an action is intended on metallic material being heated or annealed. Gases or vapours may also be supplied which bring about chemical actions on the material being heated. In the lower part 1 the anode 15 is arranged, insulated and screened, as well as the lead-through element 16 which is made hollow and to which a cooling agent may be supplied through the pipe 17, and led off through the tube 18. Between the anode 15 and the lower part 1 of the vessel there is a narrow gap of labyrinth form which is so narrow that no glow discharge is possible in the gap. Also between the anode 15 and the lead-through element 16 there is a similar narrow gap of labyrinth form. By means of an insulated screening pin 19, the lead-through element 16 carries for example a quartz plate 20 on which the material 21 to be heated is disposed in an insulated manner. In place of the quartz plate 20, a fusion crucible for example of carbon or of ceramic material, such as beryllium oxide, or even of metal may also

be provided for accommodating the material to be heated or fused. 22 and 23 are insulating rings and 24 is an insulating and pressing-on ring, which is pressed on by means of a screw arrangement not shown. 25 is a cooling duct to which a cooling agent can be supplied.

We claim:

An electrical reaction furnace heated by means of a glow discharge comprising, a separable housing having an inner surface of magnesium, means for sealing said housing, a gaseous medium with-

in the housing at a pressure between 0.05 and 10 millimeters of mercury, said housing being connected as a cathode, means for supporting material to be heated within the housing, means for insulating said supporting means with respect to the housing, and means for creating a glow discharge within the housing which emanates from the inner surface thereof to surround the material to be heated.

BERNHARD BERGHAUS.
WILHELM BURKHARDT.