

Nov. 17, 1953

J. FEERICK

2,659,150

DETACHABLE GUN SIGHT MOUNT

Filed Oct. 21, 1949

2 Sheets-Sheet 1

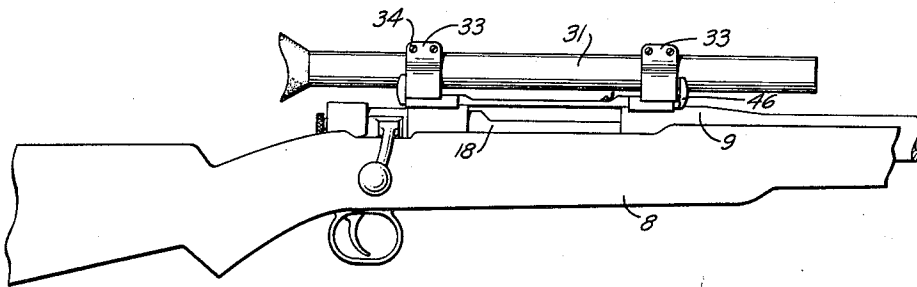

FIG. 1

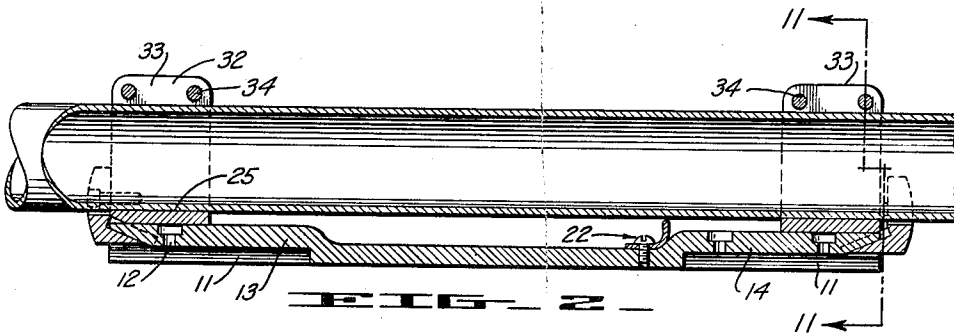

FIG. 2

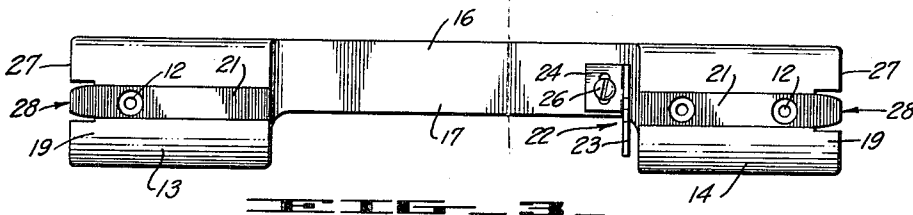

FIG. 3

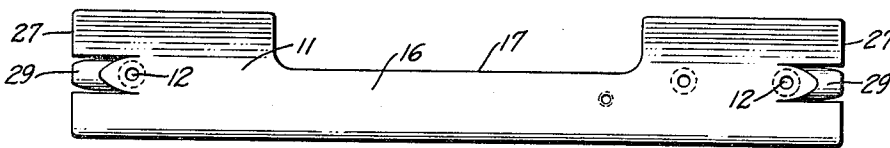

FIG. 4

INVENTOR.
JAY FEERICK
BY Joseph D. Gardner
att'y.

Nov. 17, 1953

J. FEERICK

2,659,150

DETACHABLE GUN SIGHT MOUNT

Filed Oct. 21, 1949

2 Sheets-Sheet 2

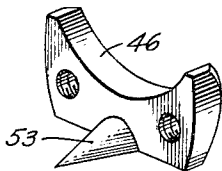
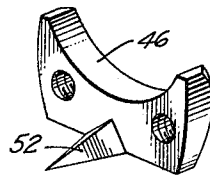
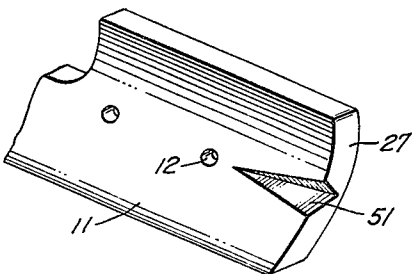
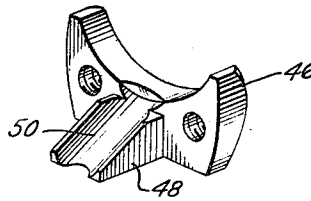
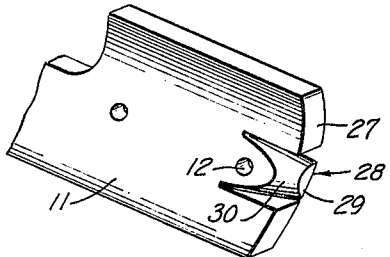
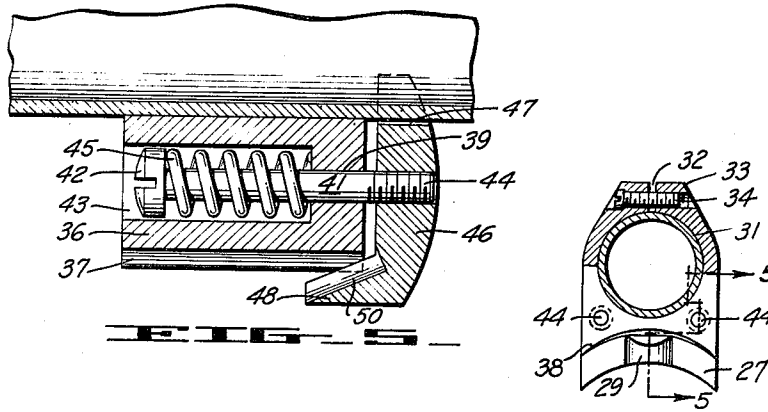

INVENTOR.
JAY FEERICK
BY Joseph B. Gendner
att'y.

UNITED STATES PATENT OFFICE

2,659,150

DETACHABLE GUN SIGHT MOUNT

Jay Feerick, Oakland, Calif., assignor, by direct and mesne assignments, of one-third to Clifford E. Welch, Hayward, Calif., and one-third to William J. Pacheco, Oakland, Calif.

Application October 21, 1949, Serial No. 122,707

4 Claims. (Cl. 33—50)

1

This invention relates to mounts for readily detachable gunsights and constitutes improvements over the structure shown and described in my prior application Serial No. 21,945, filed April 19, 1948, now abandoned.

An object of the present invention is to provide a mount for detachable telescope sights or the like in which the attachment latch elements are relatively spaced a maximum distance apart longitudinally of the telescope so as to provide for exact "zeroing" of the latter, that is, repeated precise alignment with the established sighting line each time that the telescope is remounted after having been detached.

Another object of the invention is to provide a mount of the character described which permits rapid single-handed removal or replacement of the telescope or other sighting device while the other hand is engaged in holding the gun or the like with which the sighting device may be associated.

A further object of the invention is to provide a mount of the type referred to which has been designed to lessen the development of inaccuracy which gradual wear taking place between the interengageable parts may occasion.

Yet another object of the invention is to provide quick-releasing attachment means for telescope sights which possess no tendency to develop thrust forces acting to release the attachment means in the event that transaxial rocking forces should be applied to the telescope.

Still another object of the invention is to provide a mount of the class described which, although classed as a high precision instrument, is comparatively simple in construction and is capable of production with a minimum of extremely precise machining operations.

The invention possesses other objects and features of advantage, some of which, with the description of the preferred form of the invention which is illustrated in the drawing accompanying and forming a part of the specification. It is to be understood, however, that variations in the showing made by the said drawing and description may be adopted within the scope of the invention as set forth in the claims.

Referring to the drawing:

Figure 1 is a side elevational view of a portion of a conventional rifle showing the improved gun-sight mount of my invention attached thereto.

Figure 2 is an enlarged sectional view of the mount taken in a vertical plane extending longitudinally along the telescope axis.

Figure 3 is a top plan view of the base plate.

2

Figure 4 is a bottom plan view of the base plate.

Figure 5 is an enlarged vertical sectional view taken in the plane indicated by line 5—5 of Figure 11.

Figure 6 is a bottom perspective view of an end portion of the base plate showing the preferred form of latch construction.

Figure 7 is an enlarged scale perspective view of the preferred form of latch block cooperative with the structure of Figure 6.

Figure 8 is a bottom plan view of a portion of a modified form of latch block.

Figure 9 is a view similar to Figure 7 showing a modified form of latch block cooperative with the structure of Figure 8.

Figure 10 is a view similar to Figure 9 showing a further modified form of latch block.

Figure 11 is a vertical sectional view taken in the plane indicated by the line 11—11 of Figure 2.

The average sporting rifle, when equipped with a properly aligned or "zeroed" sighting telescope is capable of extreme accuracy at ordinary and exceptionally long ranges. However, for ordinary sporting use, the telescope sight does not afford the greatest efficiency under all conditions. For instance, in foggy weather, when considerable dust is stirred up by wind, in semi-darkness, or in so-called "close" terrain where there is considerable high brush and thick tree growth, the telescope lenses may become a hindrance rather than an aid when quick aiming or "snap-shooting" must be resorted to. The ordinary open or iron sights under such extreme conditions are far more desirable than the telescopes and consequently most of the presently available sights of the latter class are found to be equipped with detachment means which permit ready removal of the telescope when its use is not desired. Many of these attachment mounts are either rather complicated in their construction, require highly precise machining operations to produce and install, are susceptible to misalignment or other damage due to the rough handling of the rifle, or do not unfailingly return the telescope to exact "zero" position each time that it is removed and replaced. In addition, some mounts are so bulky as to interfere considerably with proper aiming of the rifle when the open sights are being employed. A further disadvantage in present quick-releasing mount devices is the tendency for the latches to become dislodged or released when sidewise pressures are imposed on the telescope. In the design of the improved mount of my invention, the three most important requisites of such a mount, namely, the positive

3

relocation of the telescope at exact "zero" each time that it is mounted on the rifle, the elimination of possible accidental detachment or misalignment of the telescope, and the reduction in bulk of those portions of the device remaining as permanent attachments of the rifle when the telescope sight is detached, have been taken into consideration and have been satisfactorily met.

In Figure 1, I have shown a conventional bolt-action rifle 8, in connection with which I have chosen to illustrate my invention, it being understood, of course, and as will be apparent to those skilled in the art as the description proceeds, that installation is not limited to the particular type of gun shown, but that the structure of the invention is equally applicable to certain types of automatic rifles and other side-ejection arms. As here shown I provide a base plate which is positioned overlying the upper portion of the rifle receiver 9, has its lower surface 11 suitably contoured to fit the particular shape of the receiver on which it is mounted and is secured in place by suitable screws passing through axially vertical holes 12, formed in opposite end portions of the base plate, and entering tapped holes provided in the receiver. The location and production of the tapped screw holes in the rifle receiver is the final and most important step in "zeroing in" the telescope sight and is carried out to give the base plate a permanent location only when the exact position of the telescope to give the best aiming results has been determined as the result of repeated sighting and firing tests. The base plate here shown as an example comprises vertically thickened end portions or pads 13 and 14 respectively joined by a thinner central portion 16 cut away along one longitudinal side thereof to form a recess 17 provided for clearing the rifle bolt 18 when the latter is retracted to open the cartridge chamber and to provide adequate clearance for discharged shell cases as the latter are ejected. Each of the end portions 13 and 14 of the base plate has its upper surfaces 19 crowned to segmental cylindrical form axially parallel with the longitudinal dimension of the base plate and each crowned surface in a medial portion thereof is provided with a chordally flattened area 21 suitably finely checkered or given a dull finish so as not to cause bothersome light reflections when use is being made of the open sight 22 provided as a fixture with the base plate and formed in the upstanding flange 23 of an angle bracket whose other flange 24 is secured by a screw 26 or other suitable means to the central portion 16 of the base plate. The open sight may be positioned anywhere along the base plate but it is preferred that it be located just rearwardly of the forward one 14 of the pads.

In each end 27 of the base plate is provided a latch recess 28 preferably of rectangular cross-sectional form, enclosing a spur 29 preferably formed as an integral part of the base plate and having on the side thereof facing the bottom of the latter a semi-cylindrically shaped surface 30 which may be formed by passing a concave milling cutter longitudinally of the recess 28 and tangentially along a plane which angularly intersects the longitudinal axis of the pads 13 and 14. The recesses 28, when the base plate is mounted on the rifle receiver, immediately overlie the upper surfaces of the latter and are open at their ends coinciding with the end surfaces of the base plate.

4

The sighting telescope may be any one of the numerous standard makes available and is fitted adjacent its opposite ends with mounting blocks which are provided with bored openings 25 sized to receive the telescope barrel 31, the upper portion of each mounting block being formed with a saw slit 32 radially entering the bore 25 to provide a pair of lugs 33 joined by screws 34 by means of which the mounting blocks may be tightly clamped on and fixedly positioned relative to the telescope barrel. Each mounting block is formed with a downwardly extending foot portion 36 in the lower surface of which is provided a concavity 37 of segmental cylindrical form and preferably of slightly lesser radius than the crowned surfaces 19 of the base plate. The center of curvature of the concavities 37 lies in the same plane as the corresponding centers of the surfaces 19. The foot portions 36 of the mounting blocks are arranged to straddle the pad portions of the base plate and the slight discrepancy in radii between the surfaces 19 and 37 provides points 38 of bearing between the members at spaced locations on the base plate pad surfaces, there being a gap between all other points on said surfaces and the confronting surface 37. Thus, if a piece of grit or other unnoticed particle of foreign matter should be present on either of the pads 13 or 14 when the telescope is mounted on the base plate, the particles will not interfere with the precise seating and alignment of the telescope, which condition might obtain if the two surfaces were designed to intimately engage over most of their entire areas.

In the solid portions of at least one mounting block between the barrel bore 25 and the concave bottom surface 37, I provide a pair of relatively spaced and axially-horizontal apertures 39 sized to slidably receive the stems 41 of guide screws whose heads 42 also slide within enlarged counter-bored extensions 43 of the apertures 39 and whose threaded ends 44 are secured in suitable receiving apertures formed in a latch block 46 overlying the end of the mounting block. Compressively stressed coil springs 45 occupy the counterbores 43, bear at their respective ends against the heads 42 of the screws and the bottom of the counterbore and yieldably urge the latch blocks 46 toward the mounting block. This structure is clearly illustrated in Figure 5. A similar latch block is provided on the other mounting but is securely attached thereto by suitable screws passed through the latch block and threadedly engaged in the mounting block as will be seen in Figure 2. The upper portion of each latch block is formed with a notch 47 of larger radius than and formed to clear the telescope barrel and the lower end of each latch block extends downwardly as far as possible but not quite to the upper surface of the receiver here indicated as being coincident with the surfaces 11. It will thus be noted that the latch blocks overlie and substantially close the open ends of the recesses 28. The preferred form of latch block on the face thereof confronting an end of the base plate is provided with a spur 48, best shown in Figure 7, possessing generally the cross-sectional shape of a recess 28 and having in its upper surface a chordally cylindrical groove 50 possessing a longitudinal angularity which is identical with that of the rounded portion 30 of the spur 29 and which faces upwardly toward the axis of the telescope. The radii of curvature of the groove 50 and the spur surface 30 are iden-

tical. The arrangement and proportions of the parts are such that when the telescope with its attached mounting blocks is placed immediately over the base plate, the spurs 43 may be caused to engage in the recesses 28 to attach the telescope to the base plate. This may be accomplished by causing the telescope to approach the base plate in forwardly declined relation thereto so that the forward or spring-mounted spur 43 may be first inserted in the forward recess 28 of the base plate so as to seat the spur surface 30 in the rounded groove 50. After such insertion, a backward pull is exerted on the telescope so as to compress the springs 43 and thus extend the normal spacing between the spurs 43. This permits the rearward or rigid spur to clear the rearward end of the base plate as the telescope is lowered into substantial parallelism with the rifle barrel whereupon, upon release of the rearward pulling force, the rearward spur will be allowed to move forwardly into engagement with its associated aperture 28 so that the mating rounded surfaces 30 and 50 of the rearward mounting are also intimately engaged. It will be noted that the respective spurs 43 are forcibly urged toward each other by the spring mounting of the forward spur and the result of this action is to pull tightly the bearing points 38 of the mounting block base portions 36 into engagement with the crowned upper surfaces 19 of the pads 13 and 14. The spurs 43, as will be best seen in Figure 2, bear over the entire curved surfaces of the recesses 28. It will be noted that if transversally directed pressure, either accidentally or deliberately applied, is imposed on the telescope 31 when the latter is secured in operative position on the rifle, the resulting sidewise pressure on the latch elements will cause no longitudinal separation or loosening thereof, as occurs in other detachable mounts, for the reason that the engaged latch surfaces are cylindrical and incapable of converting rotational to axial thrust. The latch connections therefore at all times remain desirably tight.

Other forms of latch structures come within the purview of my invention such as the structure illustrated in Figures 8 and 9. As here shown, the base plate at each end thereof is provided with a recess 51 of V-shaped cross-sectional form whose opposite side surfaces extend in convergent directions into the block and whose apex intersection of the said side surfaces is thus inclined at an angle with respect to the upper similarly inclined sides of a triangularly shaped spur 52 formed on the cooperative latch blocks 46 and comprising the structural equivalent of the previously described spur 43. Thus, when the spur 52 is urged into the notch 51, only the inclined ridge of the spur will contact the intersection of the sides of the notch. Thus a plurality of dispersed points of contact between each mounting block and the base plate is provided over each of the pad portions, the spurs 52 insuring that the telescope is removed and replaced to a lateral position exactly registering with the precalibrated line of sight and the bearing points precisely reestablishing the vertical height of the telescope axis so as to also exactly register with the prescribed sighting line. Removal of the telescope sight entails, of course, a reversal of sequence of the mounting operations.

In Figure 10 is shown a modified form of spur 53 in which the upper surface comprises half of a cone which when engaged with the type of

notch 51 shown in Figure 8, bears along the sides of the latter at peripherally spaced points thus providing the multi-point bearing previously mentioned.

It will be noted that the mounting and demounting operations have been reduced to two simple movements, namely, a backward pull on the telescope and an upward lifting thereof to effect detachment, and a reversed repetition to effect reattachment. Thus it is possible for the user, while holding the rifle at the ready position with one hand and arm, to very quickly mount or detach the telescope sight as sighting conditions may require by using his other free hand. The average comparable sights presently available do not provide for such rapid action and in many cases a suddenly appearing or moving game target may vanish or move out of range before the telescope can be mounted or before the open sights may be brought into use if conditions require the employment of the latter sights. Another advantageous feature inherent in the structure of my invention is that, unlike the average comparable device, the attachment and detachment of the telescope sight may be accomplished practically noiselessly in spite of the rapidity with which they may be effected, thereby lessening the danger of alarming into flight the prospective game target.

I claim:

1. A mount for sighting telescopes comprising a base member having longitudinally spaced and relatively aligned pads having upper surfaces crowned transversely adjacent the edges thereof with respect to the plane of alignment of the pads and further having substantially flat coplanar portions adjacent the longitudinal axis of the pads, said base being further provided adjacent the lower surface of each pad with a recess provided with oppositely extending latch elements having declining side surfaces, said latch elements having their lower surfaces disposed above the lower surfaces of said pads, a pair of mounting elements adapted for engagement with portions of the body of said sighting telescope, said mounting elements having contoured lower surface portions adapted to overlie and bear against portions of the crowned upper surfaces of the pads, a latch member fixed to one of said mounting elements, a latch block mounted for movement in a direction substantially paralleling the axis of said telescope on another of said mounting elements, a latch member carried by said movable latch block, said latch members being positioned in a plane paralleling the bearing portions of the crowned and contoured surfaces, each of said latch members having a longitudinally sloping form substantially complementary with the form of said latch elements whereby when portions of the members are engaged in said latch elements the bearing points of the crowned and contoured surfaces will be brought together, and means for forcibly urging said latch members toward each other to correspondingly forcibly urge said bearing points together, the said complementary surfaces of the latch element and the latch block permitting relative movement therebetween only in a direction paralleling the longitudinal axis of said base member and said telescope.

2. A mount for sighting telescopes comprising a base including relatively aligned pads having upper surfaces crowned transversely with respect to the plane of alignment of the pads, said

7

base being further provided adjacent the lower surface thereof with oppositely extending separate latch elements having declining side surfaces converging towards the distal ends of said base, a pair of mounting elements adapted for engagement with portions of the body of said sighting telescopes, said mounting elements having contoured surface portions adapted to overlie and bear against the crowned surfaces of the pads, the radius of curvature of said latter contoured portions being larger than the radius of curvature of said upper surfaces of said pads, a latch member carried by one of said mounting elements, a movable latch block on another of said mounting elements, a latch member carried by said movable latch block, said latch members being positioned in a plane paralleling the bearing points of the crowned and contoured surfaces, each of said latch members having a grooved portion thereof inter-engageable with the respective latch elements, and spring means interposed between said movable latch block and the adjacent mounting element for forcibly urging said latch members into engagement with corresponding latch elements whereby the bearing surfaces of the crowned and contoured surfaces will be forcibly brought together.

3. A mount for sighting telescopes comprising a base including longitudinally spaced and relatively aligned pads having upper surfaces crowned transversely with respect to the plane of alignment of the pads, said base being further provided with oppositely extending latch elements having substantially semi-circular cross-sectional forms and tapered towards their respective end portions and disposed subjacent said upper surfaces, a pair of mounting elements adapted for engagement with axially spaced portions of the body of said sighting

8

telescope, said mounting elements having contoured surface portions adapted to overlie the crowned surfaces of the pads and to bear against the latter surfaces adjacent the edges thereof, a latch spur carried by one of said mounting elements, a movable latch block on another of said mounting elements, a latch spur carried by said movable latch block, each of said spurs having a portion substantially complementary with the form of said latch elements and relatively interengageable therewith, and spring means interposed between said movable latch block and the adjacent mounting element for forcibly urging said spurs into engagement with the latch elements whereby the bearing surfaces of the crowned and contoured surfaces on the pads and mounting elements respectively will be forcibly brought together.

4. Apparatus as set forth in claim 1 in which the complementary shapes of said latch member and said latch elements are of substantially triangular pyramidal form.

JAY FEERICK.

References Cited in the file of this patent

UNITED STATES PATENTS

Number	Name	Date
2,200,869	Albree	May 14, 1940
2,396,404	Williams	Mar. 12, 1946
2,450,466	Carlson	Oct. 5, 1948
2,452,145	Pike	Oct. 26, 1948
2,475,383	Foster	July 5, 1949
2,510,289	Livermore	June 6, 1950
2,526,816	Hardgrove	Oct. 24, 1950

FOREIGN PATENTS

Number	Country	Date
47,293	Switzerland	1909