



US0D1042544S

(12) **United States Design Patent**  
**Canik et al.**

(10) **Patent No.:** **US D1,042,544 S**

(45) **Date of Patent:** **\*\* Sep. 17, 2024**

(54) **AFTERTREATMENT SYSTEM**

7,836,688 B2 11/2010 Woerner et al.  
7,866,143 B2 1/2011 Buhmann et al.  
8,033,101 B2 10/2011 Amon et al.  
8,230,678 B2 7/2012 Aneja et al.

(Continued)

(71) Applicant: **Cummins Emission Solutions Inc.**,  
Columbus, IN (US)

(72) Inventors: **Jacob D. Canik**, Stoughton, WI (US);  
**Pranjal Naik**, Cupertino, CA (US);  
**Jack Rehn, III**, Madison, WI (US);  
**Richard Blaschko**, Madison, WI (US);  
**Ryan M. Johnson**, Cottage Grove, WI  
(US); **Matthew K. Volmerding**,  
Columbus, IN (US); **Jim L. Alonzo**,  
Verona, WI (US); **Randolph G. Zoran**,  
McFarland, WI (US)

**FOREIGN PATENT DOCUMENTS**

CN 1864835 A 11/2006  
CN 101501308 A 8/2009

(Continued)

**OTHER PUBLICATIONS**

Coanda effect, [https://en.wikipedia.org/w/index.php?title=Coand%  
C4%83\\_effect&oldid=1000333406](https://en.wikipedia.org/w/index.php?title=Coand%<br/>C4%83_effect&oldid=1000333406) (last visited Mar. 12, 2021).

(Continued)

(73) Assignee: **Cummins Emission Solutions Inc.**,  
Columbus, IN (US)

(\*\*) Term: **15 Years**

*Primary Examiner* — Calvin E Vansant

*Assistant Examiner* — Eidiol Ghigliotty Torres

(74) *Attorney, Agent, or Firm* — Foley & Lardner LLP

(21) Appl. No.: **29/835,755**

(22) Filed: **Apr. 21, 2022**

(57) **CLAIM**

We claim the ornamental design for an aftertreatment system, as shown and described.

(51) **LOC (14) Cl.** ..... **23-01**

(52) **U.S. Cl.** ..... **D23/365**

(58) **Field of Classification Search**

USPC ..... D15/5, 138, 199; D23/265

CPC ..... F01N 2610/00; F01N 2550/02; F01N  
2560/021; F01N 2560/026; F01N

3/02006; F01N 3/021; F01N 3/2066

See application file for complete search history.

**DESCRIPTION**

FIG. 1 is a top, front perspective view of the aftertreatment system according to an embodiment of our new design; FIG. 2 is a top view of the embodiment; FIG. 3 is a bottom view of the embodiment; FIG. 4 is a rear view of the embodiment; FIG. 5 is a front view of the embodiment; FIG. 6 is a left side view of the embodiment; and, FIG. 7 is a right side view of the embodiment.

The ornamental design that is claimed is shown in solid lines in the drawings. The broken lines in the drawings depict environmental subject matter only and form no part of the claimed design.

(56) **References Cited**

**U.S. PATENT DOCUMENTS**

1,104,963 A 7/1914 Coanda  
4,424,777 A 1/1984 Klomp  
6,444,177 B1 9/2002 Muller et al.  
7,127,884 B2 10/2006 Worner et al.  
7,581,387 B2 9/2009 Bui et al.  
7,793,490 B2 9/2010 Amon et al.

**1 Claim, 7 Drawing Sheets**

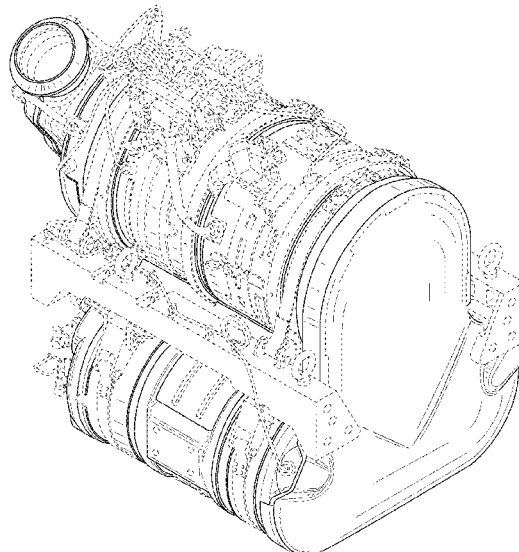

(56)	<b>References Cited</b>		11,506,101 B2	11/2022	Levato et al.	
			11,591,943 B2	2/2023	Hornback	
	U.S. PATENT DOCUMENTS		11,746,684 B2 *	9/2023	Wahlström .....	F01N 3/2892 60/282
	8,375,708 B2	2/2013	Forster et al.	2002/0023435 A1	2/2002	Woerner et al.
	8,460,610 B2	6/2013	Silver et al.	2004/0112883 A1	6/2004	Bowden et al.
	8,607,555 B2	12/2013	Kaiser et al.	2004/0237511 A1	12/2004	Ripper et al.
	8,615,984 B2	12/2013	Kornherr et al.	2005/0172615 A1	8/2005	Mahr
	8,695,330 B2	4/2014	Davidson et al.	2005/0262843 A1	12/2005	Monty
	8,776,509 B2	7/2014	Wikaryasz et al.	2006/0150614 A1	7/2006	Cummings
	8,789,363 B2	7/2014	Iverson et al.	2006/0153748 A1	7/2006	Huthwohl et al.
	9,021,794 B2	5/2015	Goss et al.	2006/0191254 A1	8/2006	Bui et al.
	9,133,744 B2	9/2015	Birkby et al.	2006/0260104 A1	11/2006	Himi
	9,248,404 B2	2/2016	Brunel et al.	2006/0266022 A1	11/2006	Woerner et al.
	9,266,075 B2	2/2016	Chapman et al.	2006/0283181 A1	12/2006	Crawley et al.
	9,267,417 B2	2/2016	Baldwin et al.	2007/0144126 A1	6/2007	Ohya et al.
	D757,919 S *	5/2016	Kimura .....	2007/0163241 A1	7/2007	Meingast et al.
			D23/365	2007/0245718 A1	10/2007	Cheng et al.
	9,328,640 B2	5/2016	Iverson et al.	2007/0283683 A1	12/2007	Bellinger
	9,346,017 B2	5/2016	Greber	2007/0289294 A1	12/2007	Werni et al.
	9,352,276 B2	5/2016	Sampath	2008/0087013 A1	4/2008	Crawley et al.
	9,453,444 B2	9/2016	Fischer et al.	2008/0121179 A1	5/2008	Park et al.
	9,464,546 B2	10/2016	Perrot et al.	2008/0127635 A1	6/2008	Hirata et al.
	9,504,960 B2	11/2016	Park	2008/0314033 A1	12/2008	Aneja et al.
	9,581,067 B2	2/2017	Guilbaud et al.	2009/0000283 A1	1/2009	Endicott et al.
	D781,071 S *	3/2017	Callif .....	2009/0019843 A1	1/2009	Levin et al.
			D6/566	2009/0031717 A1	2/2009	Blaisdell
	9,605,573 B2	3/2017	Solbrig et al.	2009/0049829 A1	2/2009	Kaiser et al.
	9,644,516 B1	5/2017	Chiruta et al.	2009/0084094 A1	4/2009	Goss et al.
	9,664,081 B2	5/2017	Rusch et al.	2009/0145119 A1	6/2009	Farrell et al.
	9,714,598 B2	7/2017	Alano et al.	2009/0158717 A1	6/2009	Kimura et al.
	D794,100 S *	8/2017	McDonald .....	2009/0158721 A1	6/2009	Wieland et al.
			D23/265	2009/0158722 A1	6/2009	Kojima et al.
	9,726,064 B2	8/2017	Alano	2009/0180937 A1	7/2009	Nohl et al.
	9,737,908 B2	8/2017	Hornback et al.	2009/0229254 A1	9/2009	Gibson
	9,776,135 B2	10/2017	Boeshans et al.	2009/0272106 A1	11/2009	Werni et al.
	D809,577 S *	2/2018	McDonald .....	2010/0083641 A1	4/2010	Makartchouk et al.
			D23/265	2010/0146942 A1	6/2010	Mayr et al.
	D816,010 S *	4/2018	Rike .....	2010/0146948 A1	6/2010	Dacosta et al.
			D8/396	2010/0187383 A1	7/2010	Olsen et al.
	9,995,193 B2	6/2018	Alano et al.	2010/0251719 A1	10/2010	Mancini et al.
	10,024,217 B1	7/2018	Johnson et al.	2010/0319329 A1	12/2010	Khadiya
	10,030,564 B2	7/2018	Cossard et al.	2011/0005232 A1	1/2011	Williams et al.
	10,174,658 B2	1/2019	Dimpelfeld et al.	2011/0079003 A1	4/2011	Sun et al.
	10,190,465 B2	1/2019	Alano et al.	2011/0094206 A1	4/2011	Liu et al.
	D840,908 S *	2/2019	Rike .....	2011/0099978 A1	5/2011	Davidson et al.
			D8/396	2011/0146237 A1	6/2011	Adelmann et al.
	10,215,075 B2	2/2019	Chapman et al.	2011/0146253 A1	6/2011	Isada et al.
	10,247,081 B2	4/2019	Niaz	2011/0194987 A1	8/2011	Hodgson et al.
	10,273,853 B2	4/2019	Golin	2012/0003955 A1	1/2012	Gabriel
	10,273,854 B1	4/2019	Abbassi et al.	2012/0124983 A1	5/2012	Hong
	D849,662 S *	5/2019	Rike .....	2012/0204541 A1	8/2012	Li et al.
			D12/218	2012/0204542 A1	8/2012	Norris et al.
	10,287,948 B1	5/2019	Moulieres et al.	2012/0204544 A1	8/2012	Uhrich et al.
	10,287,954 B2	5/2019	Chapman et al.	2012/0216513 A1	8/2012	Greber et al.
	10,294,843 B2	5/2019	Alano et al.	2013/0067891 A1	3/2013	Hittle et al.
	10,316,721 B1	6/2019	Moulieres et al.	2013/0097819 A1	4/2013	Kojima
	D855,090 S *	7/2019	McDonald .....	2013/0333363 A1	12/2013	Joshi et al.
			D23/265	2014/0033686 A1	2/2014	Fischer et al.
	10,337,379 B2	7/2019	Dimpelfeld et al.	2014/0230418 A1	8/2014	Perrot et al.
	10,337,380 B2	7/2019	Willats et al.	2014/0260209 A1	9/2014	Goss et al.
	10,422,268 B2	9/2019	Niaz	2014/0325967 A1	11/2014	Kimura
	10,533,478 B2	1/2020	Alano	2014/0373721 A1 *	12/2014	Sandou .....
	10,577,995 B2	3/2020	Ker et al.			F01N 3/0211 55/482
	10,612,443 B2	4/2020	Li et al.	2015/0000389 A1 *	1/2015	Runde .....
	10,731,536 B1	8/2020	Chenoweth et al.			F01N 3/021 73/114.75
	10,787,946 B2	9/2020	Rohde et al.	2015/0016214 A1	1/2015	Mueller
	10,808,587 B2	10/2020	Ottaviani et al.	2015/0089923 A1	4/2015	Henderson et al.
	10,823,032 B2	11/2020	Willats et al.	2015/0110681 A1	4/2015	Ferront et al.
	10,907,522 B2	2/2021	Poinsot et al.	2015/0121855 A1	5/2015	Munnannur et al.
	10,914,218 B1	2/2021	Chapman et al.	2015/0218996 A1	8/2015	Brandl et al.
	10,920,635 B2	2/2021	Kozakiewicz	2015/0224870 A1 *	8/2015	Shin .....
	10,920,642 B2	2/2021	Wang et al.			F01N 13/0097 248/213.2
	10,933,387 B2	3/2021	Cvelbar	2015/0233276 A1	8/2015	Cassity et al.
	10,967,329 B2	4/2021	Alano et al.	2015/0360176 A1	12/2015	Bui et al.
	11,085,346 B2	8/2021	Tucker et al.	2016/0061090 A1	3/2016	Anand et al.
	11,105,241 B2	8/2021	Tucker et al.	2016/0069239 A1 *	3/2016	Freeman .....
	11,143,084 B2	10/2021	Wahlstrom			F01N 13/1888 60/324
	11,193,412 B2	12/2021	Cvelbar et al.	2016/0083060 A1	3/2016	Kassianoff
	11,230,958 B2	1/2022	Tucker et al.			
	11,242,788 B2	2/2022	Kinnaird			
	11,242,790 B2	2/2022	Chapman et al.			
	11,300,028 B2	4/2022	Meunier			
	11,313,266 B2	4/2022	Tucker et al.			
	11,428,140 B1	8/2022	Kinnaird et al.			
	11,459,927 B2	10/2022	Rajashekhariah et al.			
	11,459,929 B2	10/2022	Dimpelfeld et al.			

(56)

References Cited

U.S. PATENT DOCUMENTS

2016/0090887 A1 3/2016 Mitchell et al.  
 2016/0115847 A1 4/2016 Chapman et al.  
 2016/0138454 A1 5/2016 Alano et al.  
 2016/0158714 A1 6/2016 Li et al.  
 2016/0175784 A1 6/2016 Harmon et al.  
 2016/0194991 A1 7/2016 Clayton et al.  
 2016/0243510 A1 8/2016 Denton et al.  
 2016/0251990 A1 9/2016 Dimpelfeld et al.  
 2016/0326931 A1\* 11/2016 Freeman ..... F01N 3/2066  
 2016/0332126 A1 11/2016 Nande et al.  
 2016/0361694 A1 12/2016 Brandl et al.  
 2016/0376969 A1 12/2016 Zhang et al.  
 2017/0067387 A1 3/2017 Khaled  
 2017/0107882 A1 4/2017 Chiruta et al.  
 2017/0152778 A1 6/2017 Li et al.  
 2017/0327273 A1\* 11/2017 Lee ..... B67D 1/0009  
 2017/0361273 A1 12/2017 Zoran et al.  
 2017/0370262 A1\* 12/2017 Zoran ..... F01N 13/009  
 2018/0078912 A1 3/2018 Yadav et al.  
 2018/0087428 A1 3/2018 Barr  
 2018/0142604 A1 5/2018 Niaz  
 2018/0266300 A1 9/2018 Liu et al.  
 2018/0306083 A1 10/2018 Sampath et al.  
 2018/0313247 A1 11/2018 Bauknecht et al.  
 2019/0063294 A1 2/2019 Johnson et al.  
 2019/0107025 A1 4/2019 Brinkmeyer  
 2019/0323397 A1 10/2019 Pill et al.  
 2020/0102873 A1 4/2020 Ramolivo et al.  
 2020/0123955 A1 4/2020 Liu et al.  
 2020/0332696 A1 10/2020 Chapman et al.  
 2021/0039056 A1 2/2021 De Rudder et al.  
 2021/0095587 A1 4/2021 Cvelbar et al.  
 2021/0301704 A1 9/2021 Hornback  
 2021/0301710 A1 9/2021 Cvelbar et al.  
 2021/0363907 A1 11/2021 Poinsot et al.  
 2021/0404367 A1 12/2021 Alano et al.  
 2022/0065148 A1 3/2022 Sudries et al.  
 2022/0090532 A1\* 3/2022 Degner ..... F01N 13/18  
 2022/0099121 A1\* 3/2022 Kumar ..... F01N 13/00  
 2022/0162975 A1 5/2022 Cvelbar et al.  
 2022/0162976 A1 5/2022 Alano et al.  
 2022/0178296 A1\* 6/2022 Hogan ..... F01N 13/1805  
 2022/0184567 A1 6/2022 Geant  
 2022/0316382 A1\* 10/2022 De Rudder ..... B01F 25/4315  
 2022/0349330 A1 11/2022 Chapman et al.  
 2022/0379272 A1 12/2022 Alano  
 2023/0003159 A1\* 1/2023 Mittapalli ..... F01N 3/2066  
 2023/0141549 A1\* 5/2023 Kalyanshetti ..... F01N 3/005  
 454/367

CN 210858906 U 6/2020  
 CN 211082028 U 7/2020  
 CN 211116205 U 7/2020  
 CN 211573625 U 9/2020  
 CN 212130586 U 12/2020  
 CN 212130587 U 12/2020  
 CN 212296579 U 1/2021  
 CN 112483224 A 3/2021  
 CN 212744129 U 3/2021  
 CN 214304014 U 9/2021  
 CN 214836650 U 11/2021  
 CN 214887318 U 11/2021  
 CN 215109110 U 12/2021  
 CN 215719044 U 2/2022  
 CN 215719045 U 2/2022  
 CN 216157745 U 4/2022  
 CN 216617626 U 5/2022  
 CN 217872989 U 11/2022  
 DE 10021166 A1 11/2001  
 DE 10312212 A1 11/2003  
 DE 10 2004 043 931 A1 3/2006  
 DE 10 2010 014 037 A1 11/2010  
 DE 11 2009 000 650 T5 1/2011  
 DE 11 2010 002 589 T5 11/2012  
 DE 10 2014 101 889 8/2015  
 DE 10 2014 102 798 A1 9/2015  
 DE 10 2016 222 743 A1 5/2017  
 DE 10 2016 115 030 A1 2/2018  
 DE 10 2018 127 387 A1 5/2019  
 DE 10 2007 051 510 B4 2/2021  
 EP 0 716 918 A2 6/1996  
 EP 1 716 917 A1 11/2006  
 EP 2 769 762 A1 8/2014  
 EP 2 551 482 B1 1/2015  
 EP 2 546 488 B1 4/2015  
 EP 2 551 481 B1 8/2015  
 EP 3 085 913 A1 10/2016  
 EP 3 085 915 A1 10/2016  
 EP 3 085 916 A1 10/2016  
 EP 2 570 178 B1 4/2017  
 EP 2 522 822 B1 6/2017  
 EP 2 796 684 B1 1/2018  
 EP 3 425 180 A1 1/2019  
 EP 3 699 407 A1 8/2020  
 EP 3 775 514 B1 2/2021  
 FR 2965011 A1 3/2012  
 FR 3010134 A1 3/2015  
 FR 2984953 B1 4/2015  
 FR 2977913 B1 6/2015  
 FR 3020835 A1 11/2015  
 FR 3020834 B1 6/2016  
 FR 3020835 B1 6/2016  
 FR 3098854 B1 7/2021  
 FR 3097775 B1 5/2022  
 FR 3102683 B1 6/2022  
 FR 3111664 B1 7/2022  
 FR 3110634 B1 9/2022  
 GB 2 385 545 A 8/2003  
 GB 2 558 311 A 7/2018  
 IN 201921025624 A 1/2021  
 JP 2003-056274 2/2003  
 JP 2009-156077 A 7/2009  
 JP 2010-180863 A 8/2010  
 JP 2013-133774 A 7/2013  
 WO WO-2009/024815 A2 2/2009  
 WO WO-2009/024815 A3 2/2009  
 WO WO-2010/146285 A1 12/2010  
 WO WO-2011/110885 A1 9/2011  
 WO WO-2012/110720 A1 8/2012  
 WO WO-2012/123660 A1 9/2012  
 WO WO-2016/082850 6/2016  
 WO WO-2016/111701 A1 7/2016  
 WO WO-2018/017164 A1 1/2018  
 WO WO-2018/075061 A1 4/2018  
 WO WO-2018/226626 A1 12/2018  
 WO WO-2019/029880 A1 2/2019  
 WO WO-2019/143373 A1 7/2019  
 WO WO-2020/009713 A1 1/2020  
 WO WO-2021/050819 A1 3/2021

FOREIGN PATENT DOCUMENTS

CN 101815851 A 8/2010  
 CN 102242662 11/2011  
 CN 103429864 12/2013  
 CN 105612325 A 5/2016  
 CN 105715340 A 6/2016  
 CN 205559030 U 9/2016  
 CN 106321199 1/2017  
 CN 106377919 2/2017  
 CN 206144632 U 5/2017  
 CN 206144633 U 5/2017  
 CN 107435576 A 12/2017  
 CN 108194176 A 6/2018  
 CN 108252771 A 7/2018  
 CN 109477413 3/2019  
 CN 208982145 U 6/2019  
 CN 106014560 B 7/2019  
 CN 209179849 U 7/2019  
 CN 209586479 U 11/2019  
 CN 209855888 U 12/2019  
 CN 110761876 A 2/2020  
 CN 210195855 U 3/2020  
 CN 210686097 U 6/2020

GB 2 385 545 A 8/2003  
 GB 2 558 311 A 7/2018  
 IN 201921025624 A 1/2021  
 JP 2003-056274 2/2003  
 JP 2009-156077 A 7/2009  
 JP 2010-180863 A 8/2010  
 JP 2013-133774 A 7/2013  
 WO WO-2009/024815 A2 2/2009  
 WO WO-2009/024815 A3 2/2009  
 WO WO-2010/146285 A1 12/2010  
 WO WO-2011/110885 A1 9/2011  
 WO WO-2012/110720 A1 8/2012  
 WO WO-2012/123660 A1 9/2012  
 WO WO-2016/082850 6/2016  
 WO WO-2016/111701 A1 7/2016  
 WO WO-2018/017164 A1 1/2018  
 WO WO-2018/075061 A1 4/2018  
 WO WO-2018/226626 A1 12/2018  
 WO WO-2019/029880 A1 2/2019  
 WO WO-2019/143373 A1 7/2019  
 WO WO-2020/009713 A1 1/2020  
 WO WO-2021/050819 A1 3/2021

(56)

**References Cited**

## FOREIGN PATENT DOCUMENTS

WO	WO-2021/112826 A1	6/2021
WO	WO-2021/113246 A1	6/2021
WO	WO-2021/173357 A1	9/2021
WO	WO-2021/225824	11/2021

## OTHER PUBLICATIONS

Combined Search and Examination Report in GB2205057.9, dated May 5, 2022.

Examination Report in U.K. Patent Application No. 1413056.1 issued Sep. 21, 2017.

Examination Report in U.K. Patent Application No. 1805598.8 issued Apr. 24, 2018.

Examination Report in UK Patent Application No. GB2305850.6 issued May 26, 2023.

Examination Report in UK Patent Application No. GB 1917608.0 issued Sep. 6, 2021.

Final Office Action in U.S. Appl. No. 17/695,580 issued Feb. 6, 2023.

Final Office Action in U.S. Appl. No. 13/837,446 issued Jan. 5, 2015.

First Examination Report in Indian Patent Application No. 201947050068, issued Jan. 13, 2021.

First Examination Report in Indian Patent Application No. 202147057999, issued Mar. 14, 2022.

First Office Action in Chinese Patent Application No. 201880001223.6, issued Dec. 17, 2020.

Office Action in German Patent Application No. 102014002750.3, issued Jan. 24, 2022.

G. Comes, "Theoretical Modeling, Design and Simulation of an Innovative Diverting Valve Based on Coanda Effect", *Fluids* 2018, 3, 103, (2018).

International Search Report and Written Opinion in PCT Application No. PCT/US2012/022582 issued Oct. 25, 2012.

International Search Report and Written Opinion in PCT Application No. PCT/US2020/062718 issued Feb. 19, 2021.

International Search Report and Written Opinion in PCT Application No. PCT/IB2019/054988 dated Jan. 29, 2020.

International Search Report and Written Opinion in PCT Application No. PCT/US2021/017551 issued Apr. 28, 2021.

International Search Report and Written Opinion in PCT Application No. PCT/US2022/014781 issued Apr. 25, 2022.

International Search Report and Written Opinion in PCT Application No. PCT/US2021/029282 issued Jul. 27, 2021.

International Search Report from corresponding PCT Application No. PCT/US2018/035959, issued Oct. 19, 2018.

Office Action in U.S. Appl. No. 15/657,941 issued Aug. 6, 2019.

Office Action in U.S. Appl. No. 16/618,716 issued Feb. 23, 2021.

Office Action in U.S. Appl. No. 17/400,567 issued May 23, 2022.

Office Action in U.S. Appl. No. 17/695,580 issued Jul. 27, 2022.

Office Action in U.S. Appl. No. 17/923,804 issued Mar. 16, 2023.

Office Action in U.S. Appl. No. 18/033,021 issued Jul. 18, 2023.

Office Action in Chinese Patent Application No. 202210283795.6, dated Mar. 20, 2023.

Office Action in German Patent Application No. DE 11 2012 005 741.4 issued Dec. 7, 2022, including translation.

Preliminary Office Action in Brazilian Patent Application No. BR1120190253246, issued Apr. 26, 2022.

Search and Examination Report in UK Patent Application No. GB2116026.2 issued Dec. 20, 2021.

Search Report and Written Opinion in PCT Application No. PCT/US2019/064232 issued Feb. 12, 2020.

Search Report in UK Patent Application No. GB 2101393.3, issued Feb. 22, 2021.

Search Report Letter in UK Patent Application No. GB 2101393.3, issued Feb. 22, 2021.

US Office Action in U.S. Appl. No. 13/837,446 issued Aug. 29, 2014.

US Office Action in U.S. Appl. No. 14/372,810 issued Mar. 8, 2017.

US Office Action in U.S. Appl. No. 14/372,810 issued May 25, 2016.

Written Opinion in PCT Application No. PCT/US2018/035959, issued Oct. 19, 2018.

Extended European Search Report in European Patent Application No. 19955166.4 dated Jul. 10, 2023.

Office Action in Chinese Patent Application No. 2021800162220 issued Mar. 17, 2023.

International Search Report and Written Opinion issued for PCT Application No. PCT/US2021/056073, issued Jan. 26, 2022, 15 pages.

Non-Final Office Action issued Oct. 4, 2023 in U.S. Appl. No. 29/835,777.

Office Action issued Sep. 13, 2023 in Chinese Patent Application No. 202180064965-5.

\* cited by examiner

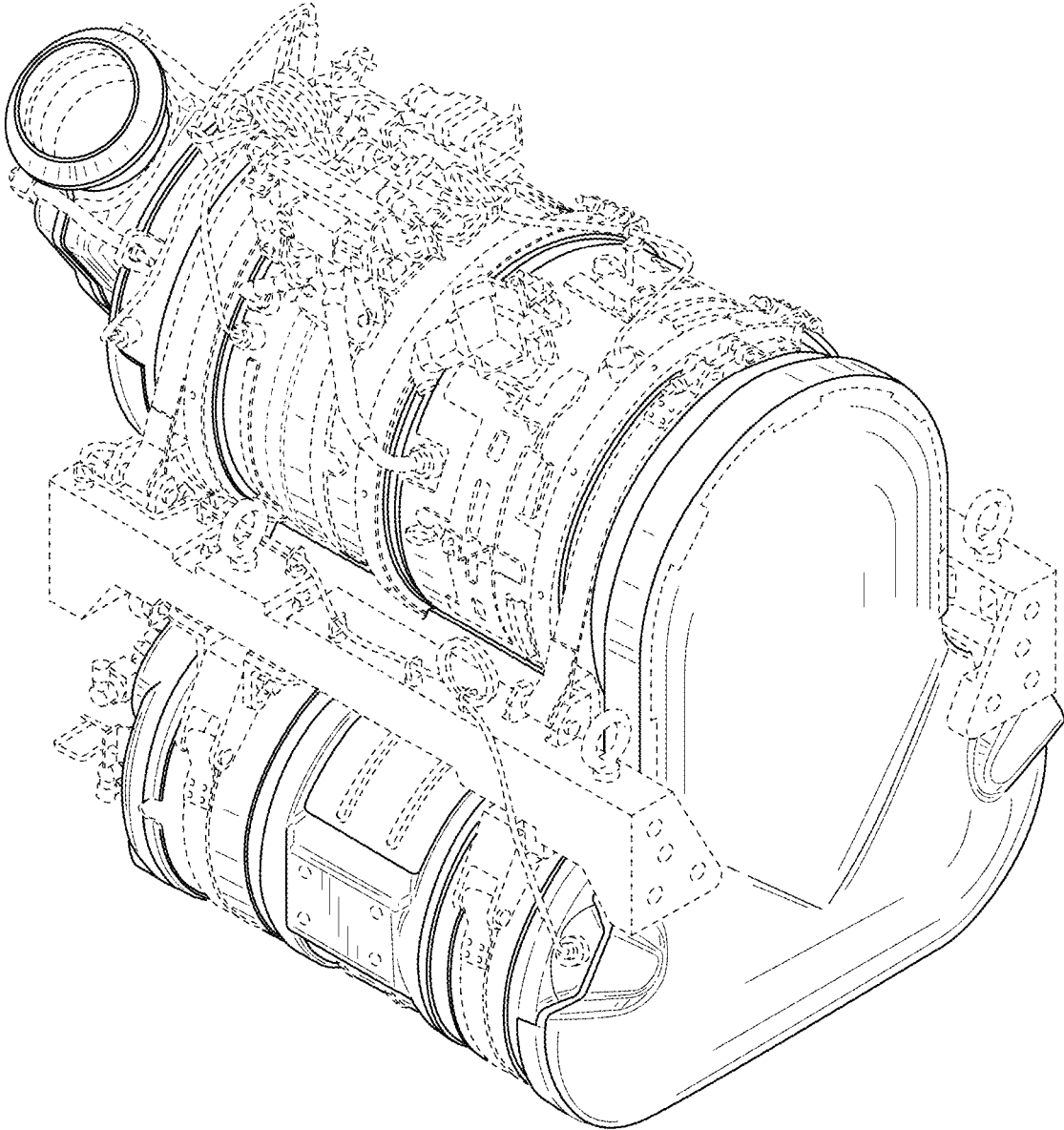

FIG. 1

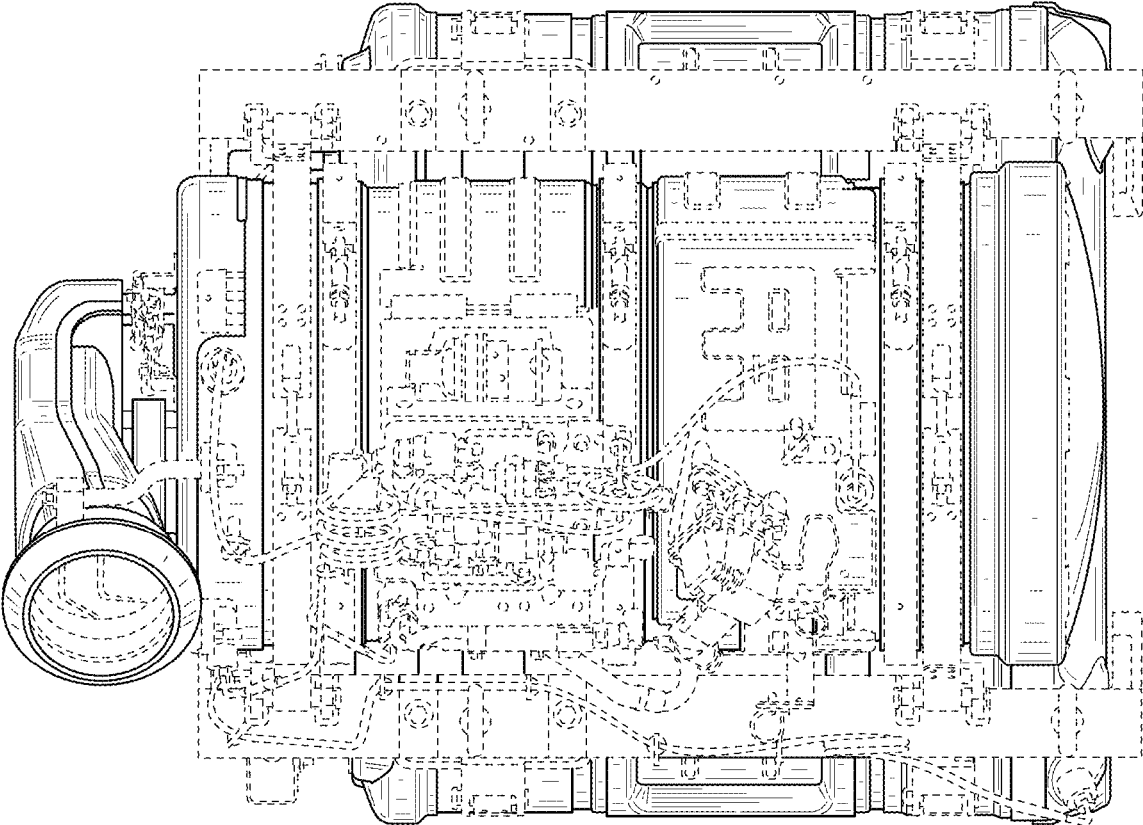

FIG. 2

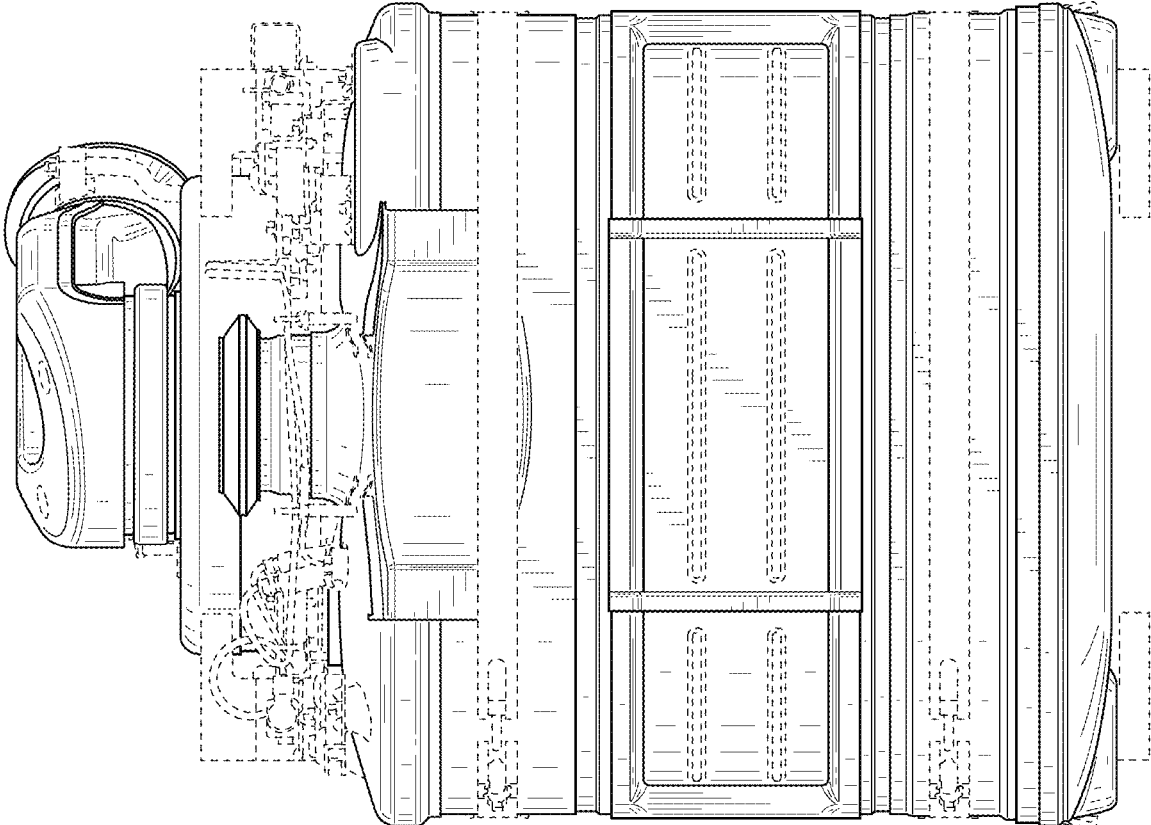

FIG. 3

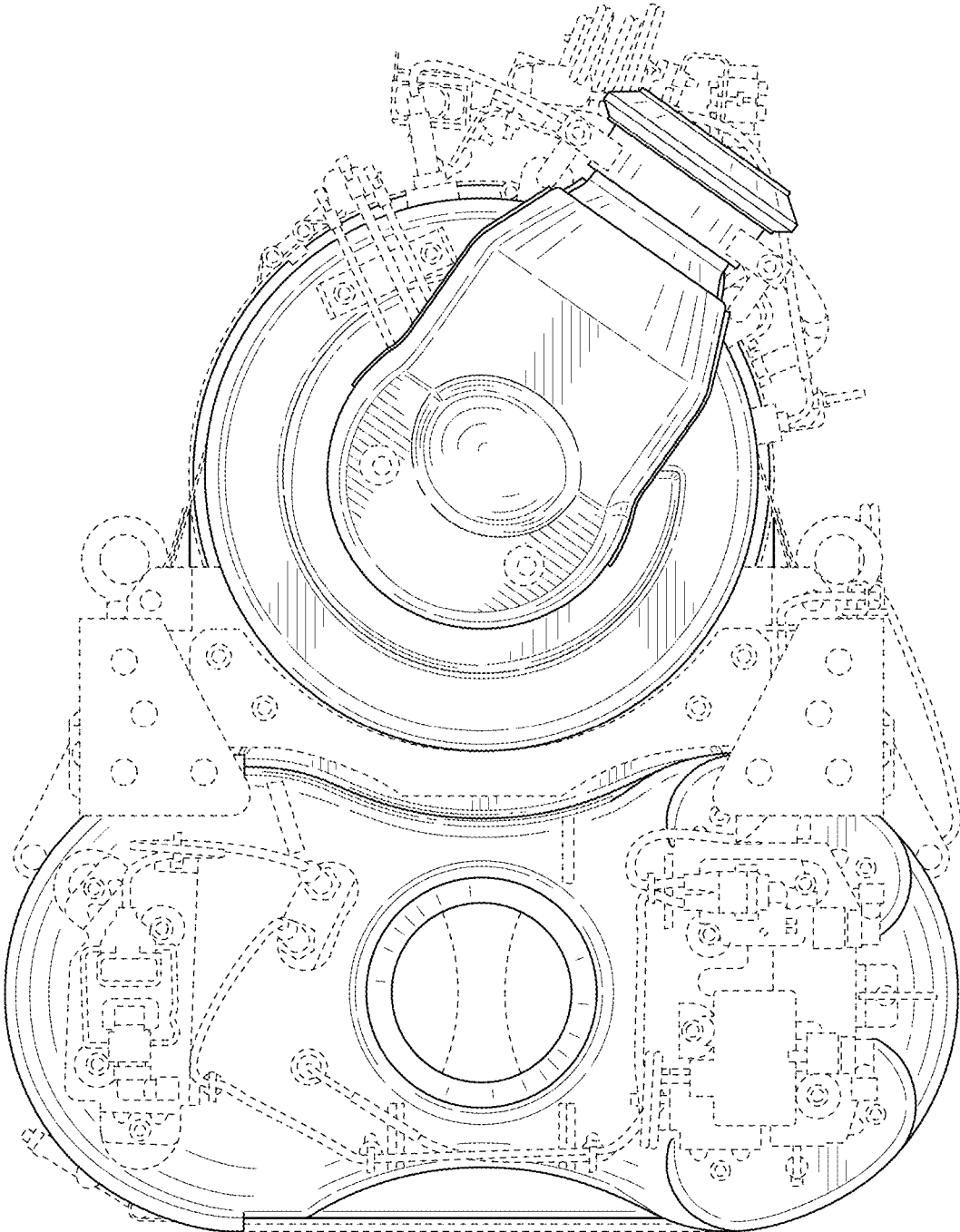

FIG. 4

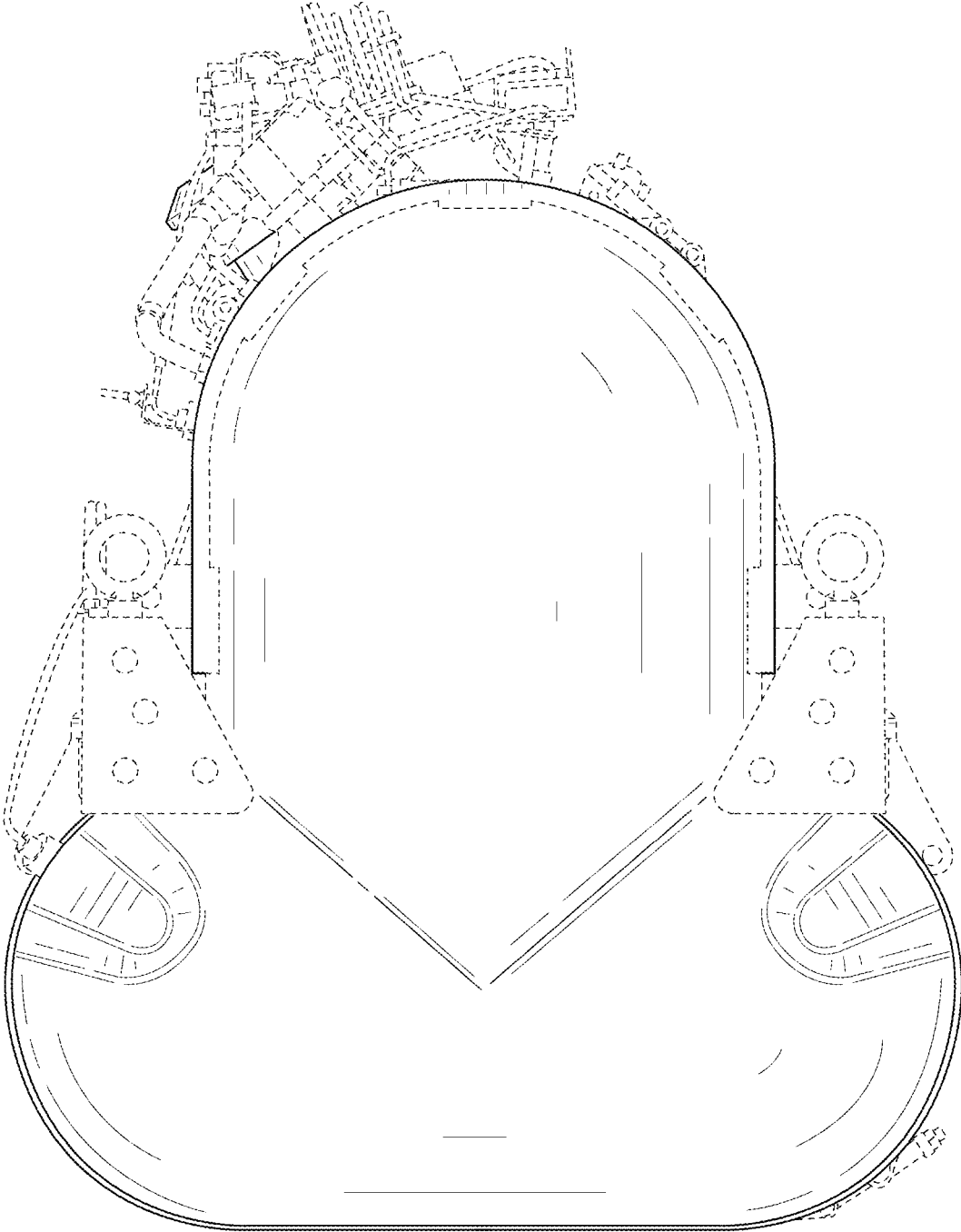

FIG. 5

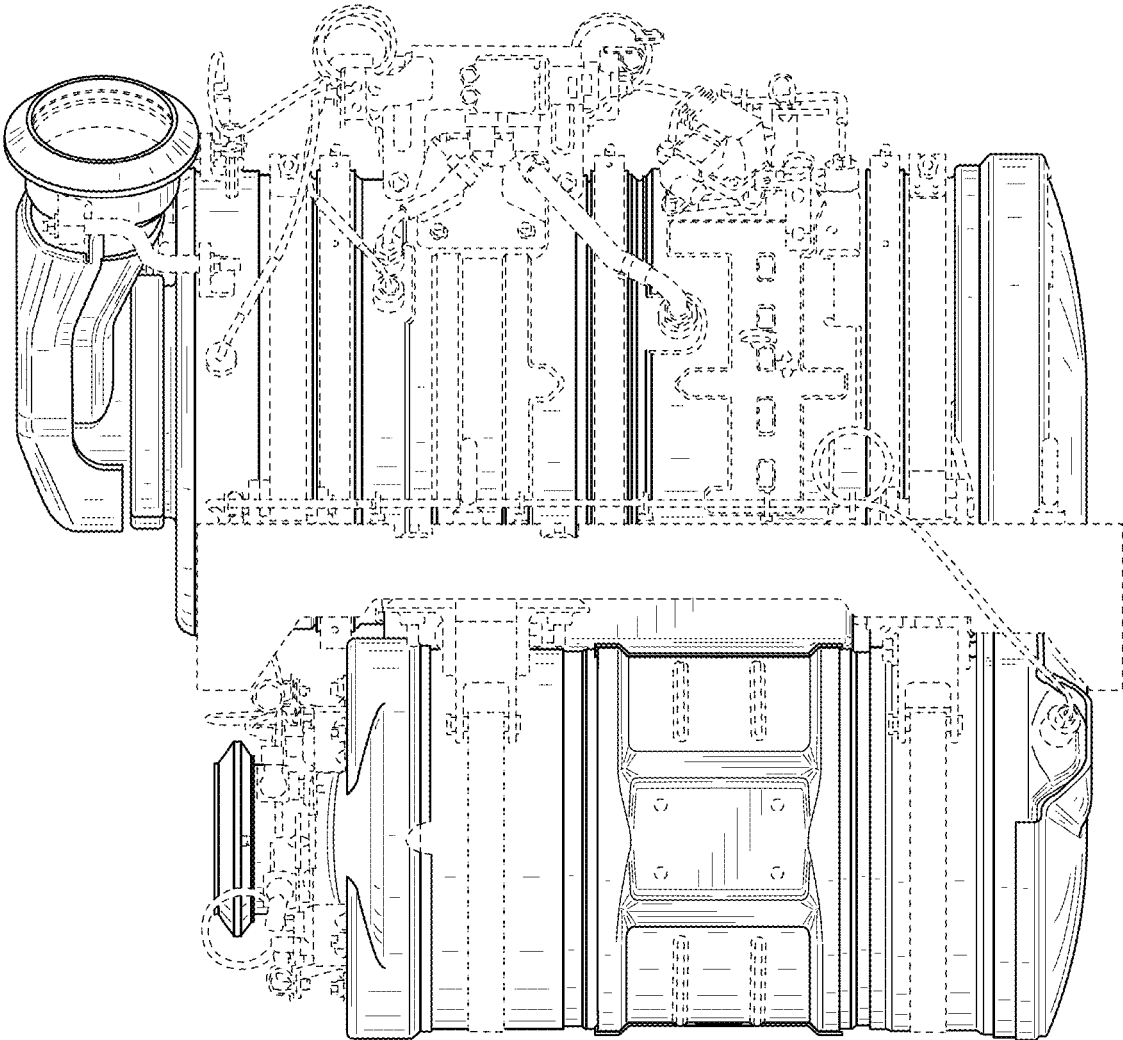

FIG. 6

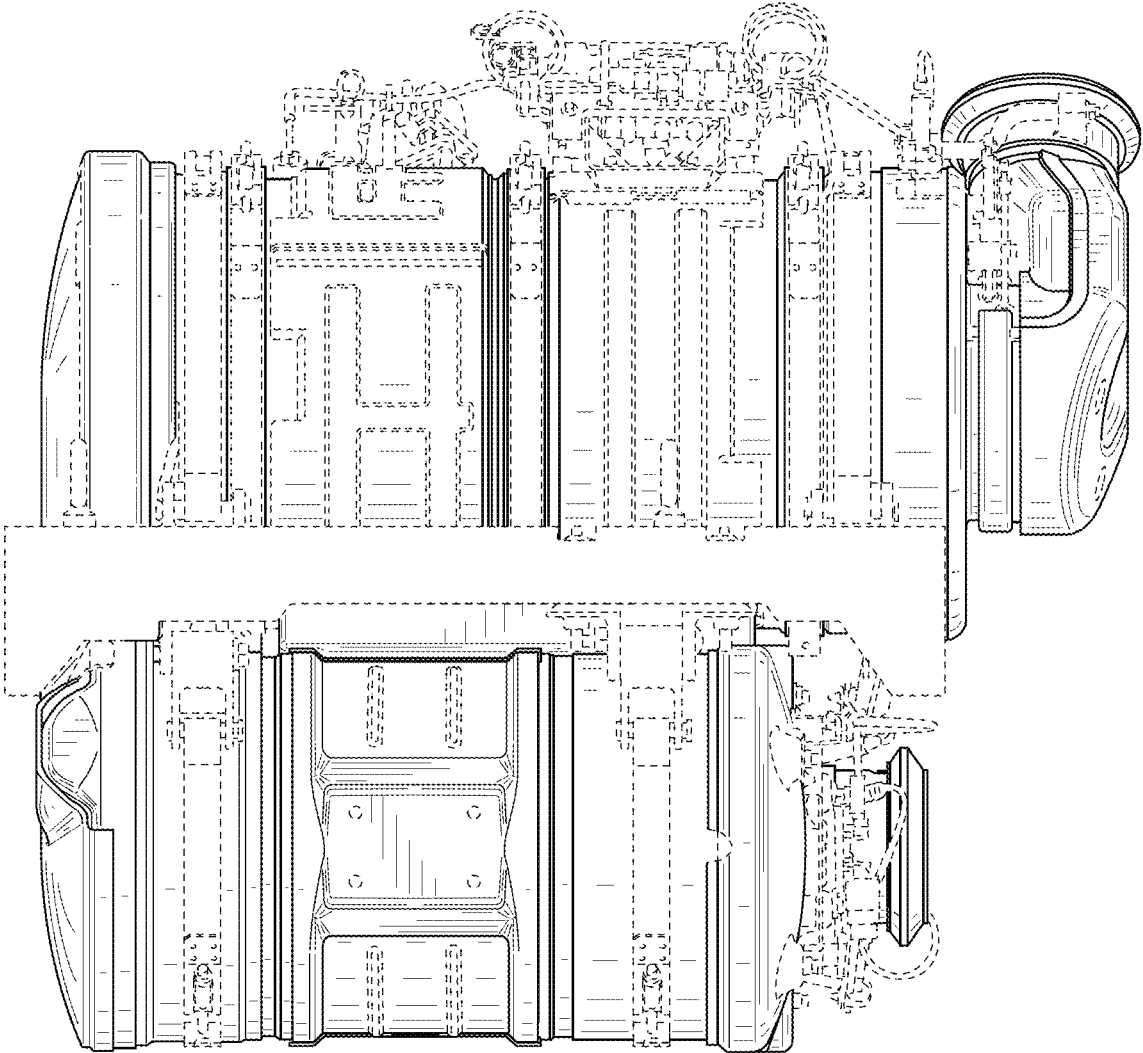

FIG. 7