

March 14, 1944.

H. B. TUTHILL

2,344,185

LABELING MACHINE

Filed May 17, 1943

4 Sheets-Sheet 1

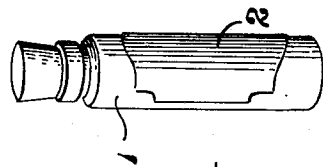

Fig. 1.

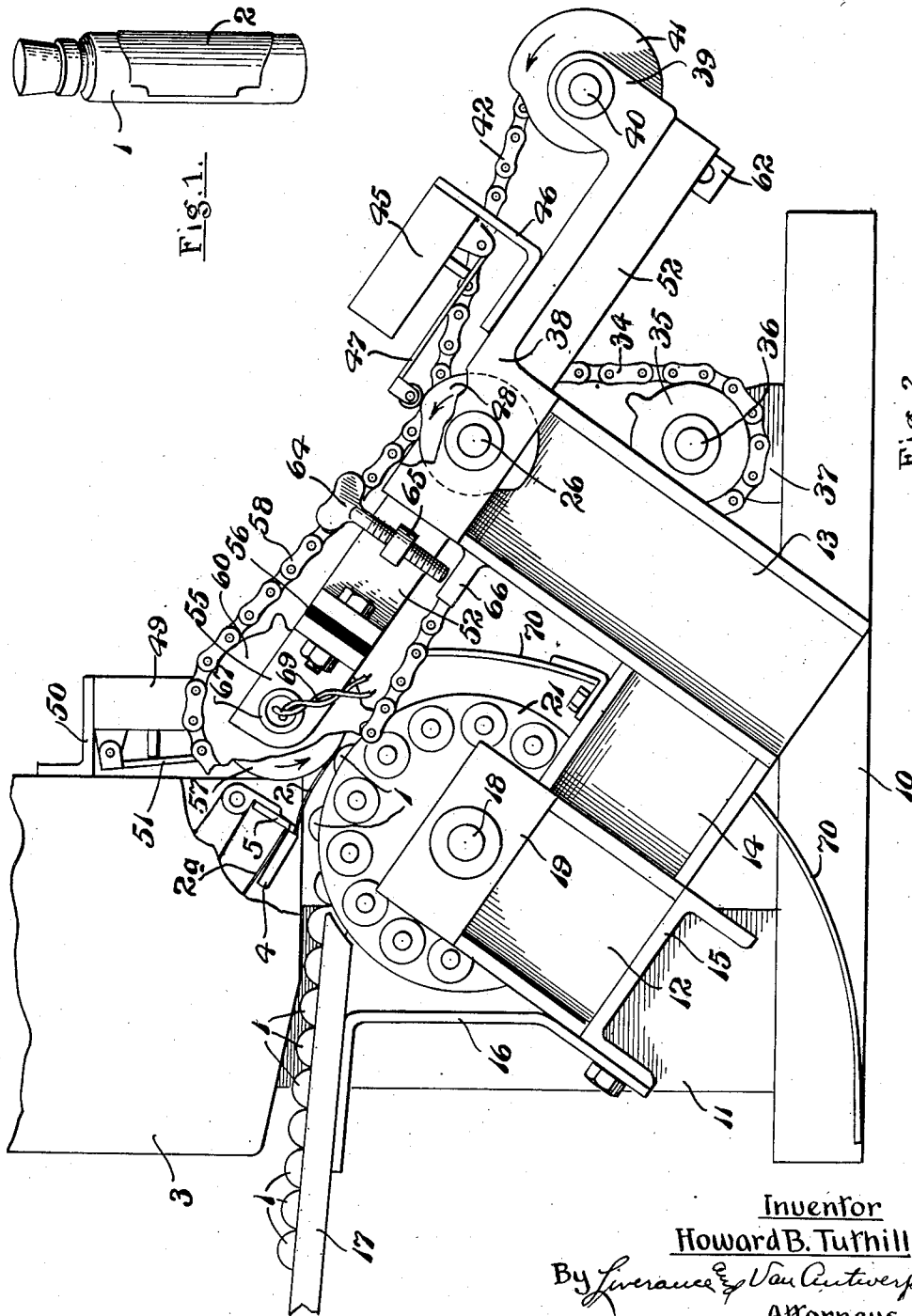

Fig. 2.

Inventor
Howard B. Tuthill

By *Leverance & Van Antwerp*
Attorneys

March 14, 1944.

H. B. TUTHILL

2,344,185

LABELING MACHINE

Filed May 17, 1943.

4 Sheets-Sheet 2

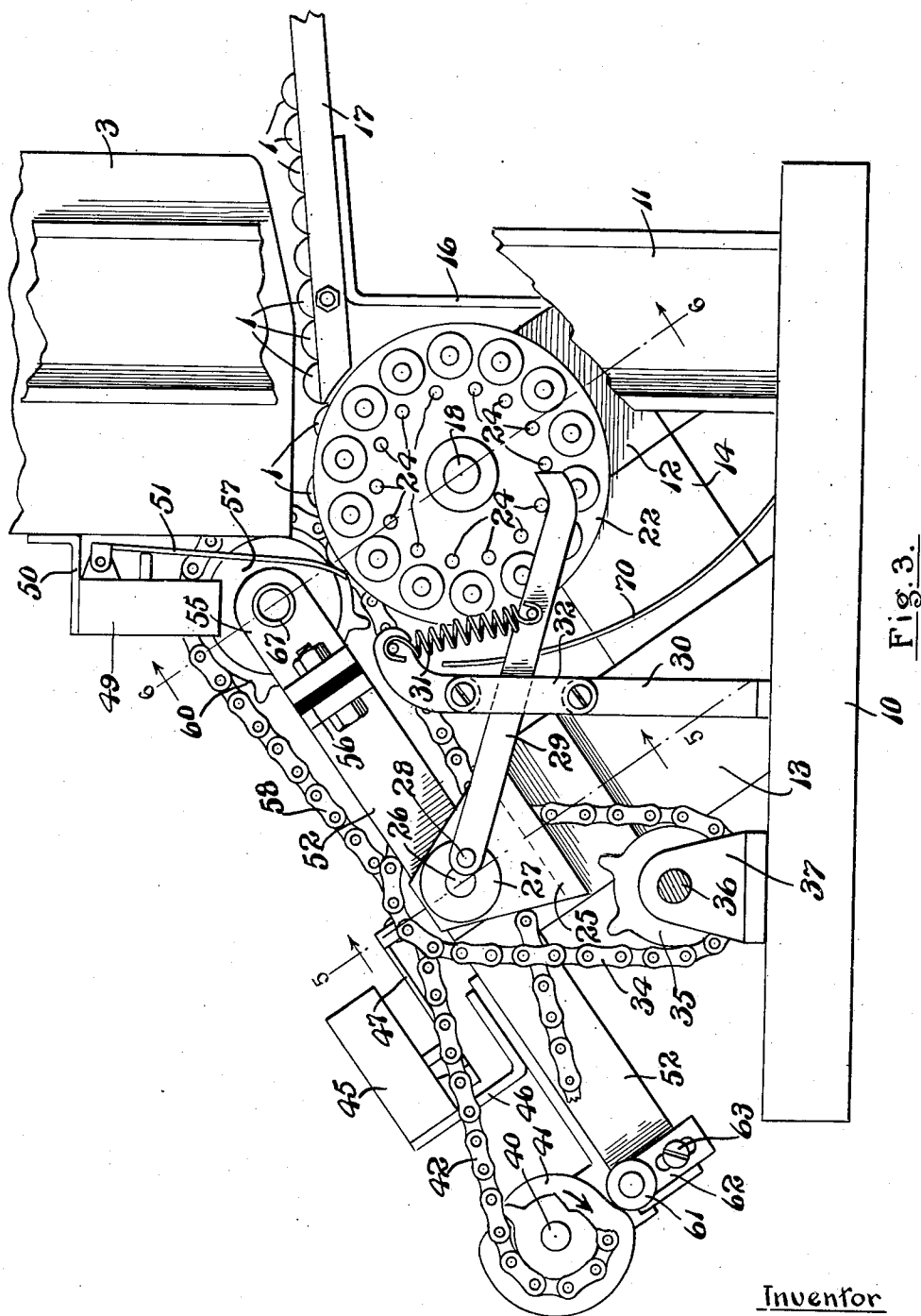

10 Fig. 3.

Inventor
Howard B. Tuthill
By *Liverance Van Antwerp*
Attorneys

March 14, 1944.

H. B. TUTHILL
LABELING MACHINE

2,344,185

Filed May 17, 1943

4 Sheets-Sheet 3

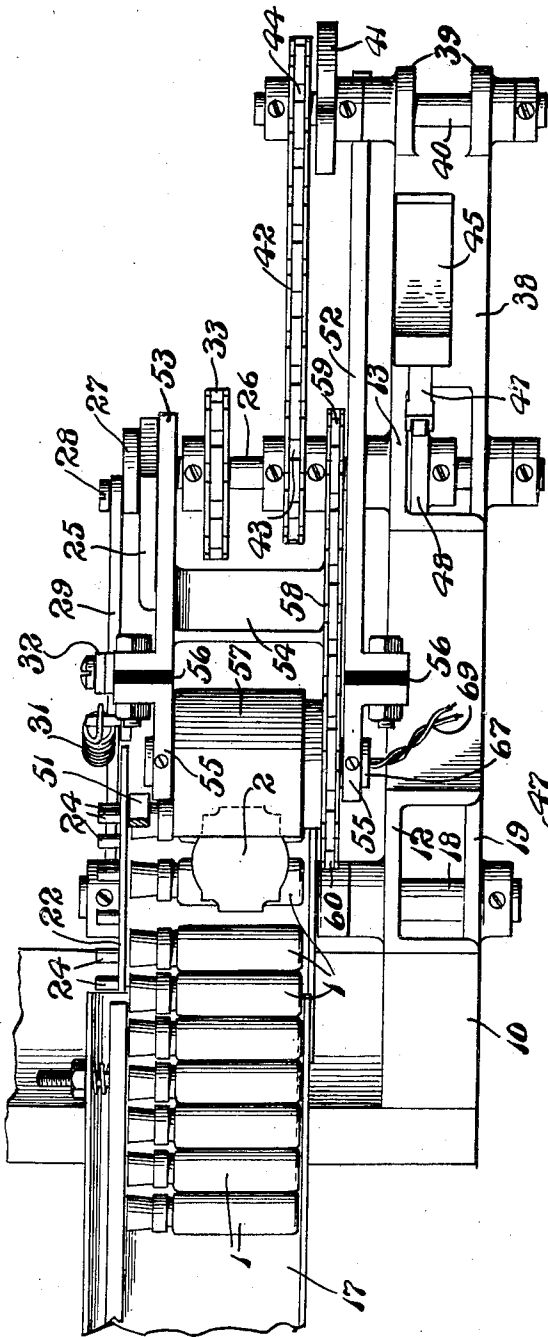

Fig. 4.

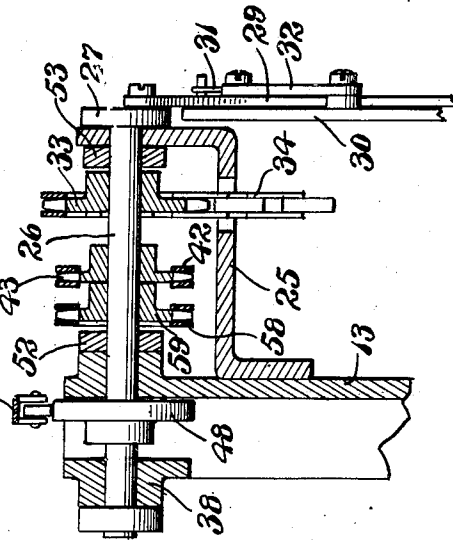

Fig. 5.

Inventor
Howard B. Tuthill
By *Liverance E. Van Antwerp*
Attorneys

March 14, 1944.

H. B. TUTHILL
LABELING MACHINE
Filed May 17, 1943

2,344,185

4 Sheets-Sheet 4

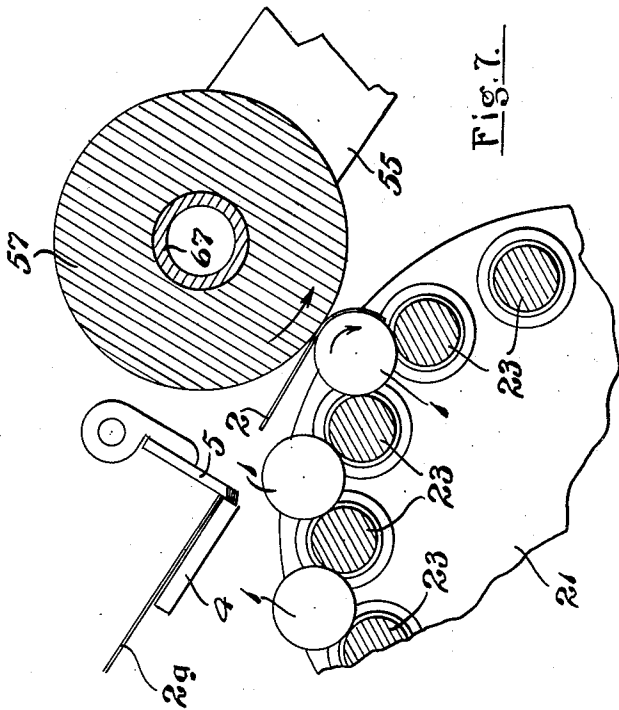

Fig. 7.

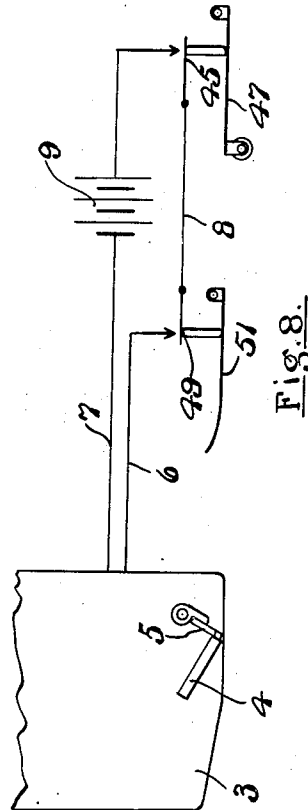

Fig. 8.

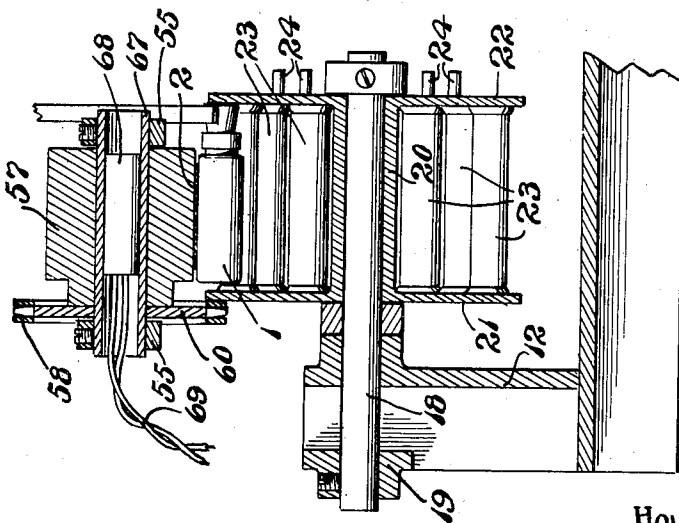

Fig. 6.

Inventor
Howard B. Tuthill
By *Liverance & Van Antwerp*
Attorneys

UNITED STATES PATENT OFFICE

2,344,185

LABELING MACHINE

Howard B. Tuthill, Grand Rapids, Mich., assignor
to Oliver Machinery Company, Grand Rapids,
Mich., a limited partnership of Michigan

Application May 17, 1943, Serial No. 487,233

11 Claims. (Cl. 216—29)

This invention relates to labeling machines, and is concerned with an attachment for or an improvement in connection with the label attaching machine disclosed in my prior Patent No. 2,329,669, issued Sept. 11, 1943.

In the machine shown in the above application, labels are severed in succession one after another at the end of a continuous strip of labels which may be rolled into a roll for ease of handling and economy of space and are successively deposited on the articles and sealed each to its respective article. In such construction the labels are attached each to a substantially flat surface on the article or wrapper in which the article is contained. The tripping and rendering operative of the label feeding, severing and depositing is controlled by the passage of the article substantially in a straight direction underneath the label attaching mechanism so that each article trips and renders operative the mechanism to deposit a label against a surface thereof and seal the label to said surface in the passage of the article.

With the present invention the same mechanism is used for holding the roll of connected labels and for severing them one at a time at the end of the roll in succession, one for each article to be label equipped. It is a primary object and purpose of the present invention to apply and secure the labels to articles having substantially curved surfaces, for example, phials or the like or other articles of a similar form or contour. It is to be understood that the articles to which the labels are applied are not necessarily of a perfectly cylindrical form but are such that they may be rocked, turned or rotated each about its longitudinal axis during the application of the label thereto.

The present invention is concerned with novel constructions for accomplishing the rapid and effective label application and attachment to articles of the type noted, as will be understood from the following description taken in connection with the accompanying drawings, in which, Fig. 1 is a perspective view illustrating a phial with the label attached.

Fig. 2 is a side elevation of the label attaching improvement by means of which the labels may be attached to the surfaces of phials or like articles having similar form.

Fig. 3 is an elevation from the opposite side of the machine.

Fig. 4 is a plan view of the novel attachment of the present invention.

Figs. 5 and 6 are transverse sections substan-

tially on the planes of lines 5—5 and 6—6 of Fig. 3 looking in the directions indicated by the arrows.

Fig. 7 is a fragmentary enlarged section illustrating the presser roller bearing against a label which is being attached around a substantially cylindrical article, and

Fig. 8 is a diagrammatic view of the electrical wiring and switches for the electric circuit which is used in the operation of the invention.

Like reference characters refer to like parts in the different figures of the drawings.

As shown in Fig. 1 an example of an article of the type to which a label is to be successively applied and secured is shown comprising a phial or small bottle 1 of cylindrical form, the label 2 cemented thereto being partially wrapped around the phial.

The connected length of labels in a roll and the mechanism for successively severing end labels one after another from the label length 2a (Fig. 2) is housed within the housing structure 3, the interior mechanism of which is identical with that shown in my prior application, Ser. No. 480,901. Upon energizing the electric mechanism disclosed in such prior application the label strip is fed a step forward and the end label 2 severed from the label upon strip 2a passing above a stationary blade 4 cooperating with which is a movable severing blade 5 as shown in Figs. 3, 7 and 8, identical with the construction in my prior application. The energizing of the electric apparatus is upon completion of an electric circuit which includes the circuit wires 6, 7 and 8, diagrammatically shown in Fig. 8, in which a source of electric energy 9 is located and with two switches, preferably, between the wire 8 and the wires 6 and 7. Such switches are properly closed in a timely manner in the operation of the machine, as will be hereinafter described, so as to complete the electric circuit and accomplish the feeding and severing of the labels at the proper times therefor.

The label securing structure or attachment to the label feeding and severing part of the mechanism is disposed partly below and partly to the front of said label feeding and severing mechanism. It includes a base 10 to be mounted upon the floor, a vertical post 11 on which the label feeding and severing mechanism may be mounted for vertical adjustment in a manner like or equivalent to that shown in my prior application, and a supporting frame structure which includes the spaced channels 12 and 13 extending in an upward and forward direction, a short connect-

ing channel 14 between their lower ends and a mounting channel 15 extending horizontally to and secured to the post 11. On a bracket 16 mounted on the support 15 an inclined feed chute 17 is secured down which the articles 1 roll by gravity and pass from the feed chute one after another to a receiving spool or wheel on which they are carried during the time of label affixing.

At the upper end of the short supporting channel 12 a horizontal stub shaft 18 is mounted at one part on the web of the channel and at another part on a plate 19 secured at the open side of the support 12 (Fig. 6). The stub shaft is held against movement and on its projecting free end portion a spool or wheel is mounted for rotation including a central sleeve 20 at the ends of which the sides 21 and 22 of the spool are secured or formed integral with the sleeve (Fig. 6). Between said spaced sides 21 and 22 a plurality of equally spaced freely rotatable rollers 23 are mounted around the spool as shown and it is between adjacent rollers that the articles 1 are to be deposited (Fig. 7) on leaving the chute 17.

The side 22 of the spool farthest away from the support 12 is provided with a continuous series of horizontally projecting pins 24, as many in number as the rollers 23, and located substantially in a circle about the axis of the shaft 18 and at substantially equal radial distances therefrom.

A bracket 25 (Figs. 3 and 5) of Z-form is mounted adjacent the upper end of the channel support 13. A horizontal shaft 26 is rotatably mounted on and carried by said support 13 and the bracket. At the end thereof nearest the bracket 25 a circular disk 27 is secured carrying a pin 28 at a distance from the axis of the shaft 26 (Fig. 3). A feed bar 29 is pivotally mounted at one end on the pin 28 and extends downwardly and to the rear to and underneath the pins 24 previously described, the free end of the feed bar 29 being turned and inclined upwardly as shown in Fig. 3 so that the end of the bar may come against one of the pins 24 and underneath the next adjacent pin. A vertical bar 30 is secured to the base 10 and extends upwardly alongside of and between the ends of the feed bar 29. A coiled tension spring 31 is secured at opposite ends to the upper end of the bar 30 and the feed bar 29, the effect of which is to yieldingly elevate the free end of the feed bar 29 against the pins 24 as in Fig. 3. A second short bar 32 is secured at its ends in spaced parallel relation to the vertical bar 30 and between the bars 30 and 32, the feed bar 29 is guided.

A sprocket wheel 33 is secured to the shaft 26 around which an endless chain 34 passes, said chain also passing around a second sprocket wheel 25 mounted on a shaft 36 which in turn has a rotative mounting upon a suitable supporting bracket or brackets 37 fixed to the base 10 (Fig. 3). The shaft 36 is the drive shaft of the machine and when the machine is operating is continuously driven from any suitable source of power, thereby through the chain 34 driving the shafts 26 and 36 continuously.

At the upper end of the channel support 13 a bar 38 is secured adjacent one end and extends downwardly and forwardly and has at its free end two spaced upwardly extending ears 39 equipped with bearings for mounting a short shaft 40 which at one end portion carries a cam 41 of the shape best shown in Fig. 3, that is,

the cam has two arc shaped edges, each struck on the arc of a circle but one of a longer radius than the other, the curved edge having the longer radius being slightly greater than semi-circular in length and the other of a shorter radius correspondingly less than semi-circular in length. The shaft 40 is continuously driven by a chain 42 passing around a sprocket wheel 43 on said shaft and a corresponding wheel 44 on the shaft 26.

At the upper side of the bar 38 a make and break electric switch 45 is mounted on a bracket 46, associated with which is a pivoted switch closure lever 47 equipped at its free end with a roller which rides upon the edges of a cam 48 on shaft 26. The cam 48 is of the same configuration as the cam 41, the switch lever 47 being elevated to close the switch at 45 upon the roller riding on the curved edge of the cam 48 having the greater radius, and being opened when the lever drops upon reaching the curved edge of the cam 48 having the shorter radius. This is one of the switches used in the electric circuit diagrammatically shown in Fig. 8 as between the circuit wires 7 and 8.

A second switch 49 of a similar construction is mounted on a bracket 50 connected to a side of the label feeding and severing apparatus (Fig. 2) and which carries a switch closing lever 51 which depends from its pivotally connected end downward into the path of movement of the articles 1 (Fig. 2). Said articles in succession as they come to the switch lever 51 move it to the left (Fig. 3) and successively close the switch 49. Switch 49 is the second switch which controls the closing of the circuit of the operating mechanism of the label feeding and severing machine and is shown as interposed between the circuit wires 6 and 7 in Fig. 8. In practice the switch 49 will be closed a short time ahead of the switch 45. If through any reason an article to be labeled should not be deposited between and carried by any two of the consecutive rollers 23, no label will be fed forward and severed because the switch 49 will not be closed, though the switch at 45 is closed and held closed for a time during each revolution of the shaft 26. However the switch 49 is not necessarily used, though desirable, as an operation of the label and forwarding mechanism with no article 1 provided to which to apply the label severed results only in loss of such label.

On shaft 26 between the upper end of the channel support 13 and the bracket 25 a presser drum frame is pivotally mounted, including a relatively long side bar 52, a shorter side bar 53 and a connecting cross member 54. At the forward ends of the bars 52 and 53 spaced extension brackets 55 are bolted with heat insulating material 56 interposed as shown. A presser drum 57 is mounted for rotation between the extensions 55 of the sides of the frame and is continuously driven when the machine is in operation by a chain 58 passing around a sprocket 59 on the shaft 26 and a similar wheel 60 on the drum 57.

At the rear end of the bar 52 a roller 61 positioned to ride against the edges of the cam 41 is mounted at the upper end of a slotted bar 62 through the slot of which an adjusting and securing screw 63 passes to the bar 52 permitting the roller 61 to be adjusted a limited distance with respect to the cam 41. The drum 57 being relatively heavy in weight normally when free to do so will move in a downward direction but

is adjustably limited in such movement by means of the screw 54 (Fig. 2) threading through a lug 65 extending from the bar 52, the lower end of the screw coming against a stop lug 56 on the channel support 13 when in lowermost position.

In the construction shown the drum 57 is mounted to turn about a hollow sleeve 67, the end portions of which are secured to the extension brackets 55 (Fig. 6). Within the sleeve an electric heating element 68 is located, electric circuit wires 69 being indicated for the conduction of current to the heating element which is heated by the usual resistance coils or the like forming a part of the heating element.

In operation, the drive shaft 36 being continuously driven there is a periodic turning in step by step movements of the wheel or spool upon which the rollers 23 are mounted for a successive feeding of the articles rolling down the chute 17 to said rollers with successive positioning of the articles between successive rollers and a supporting of the articles by the rollers as best indicated in Fig. 7.

The feeding is on the movement to the right (Fig. 3) of the feed bar 29, the end of the bar coming against a pin 24. In Fig. 3 the feeding movement has been completed and thereafter the bar 29 is retracted, with a riding of its end portion underneath the next succeeding pin 24, until the bar passes by said pin whereupon it is pulled upwardly by spring 31 against the next pin with the end of the bar in position to push against said next succeeding pin, whereupon with the further rotation of the shaft 26 and the disk 27 such next succeeding pin is engaged by the end of the bar and a feeding of the article carrying spool or wheel repeated by a step of movement.

Such feeding of the wheel carries the article 1 about to be labeled against the switch member 51 closing the switch 49. Shortly thereafter the cam 48 operates the switch lever 47 closing the switch 45 whereupon the label feeding and severing mechanism is operated due to the closing of the electric circuit (Fig. 8) and a label 2 is fed and severed from the continuous label strip 2a, the end portion of the label 2 severed being substantially directly over the article 1 which is to have the label applied.

While these operations have been taking place the cam 41 at the edge thereof having the greater radius will have been riding against the roller 61 depressing the free end of the bar 52 with a consequent rocking of the frame which carries the heated presser roller 57, lifting the roller sufficiently that the extreme end portion of the label will pass between the lower side of the drum 57 and the article 1 which is to receive the label, but immediately thereafter cam 41 will move to the position in Fig. 3 and the drum come against the upper side of the label. When this occurs or immediately after it occurs the severing of the label 2 takes place, the article carrying wheel or spool will be at rest, and the feed bar 29 will be retracted for engagement with the next succeeding pin 24. The drum 57 rotating continuously and bearing against the label, with the label bearing against the article to which it is to be applied, the result is a rotation of the article upon the rollers 23 which carry it and a continuous application of the label 2 to the article 1, continuing the wrapping of the label around the article 1, the initial portion of which wrapping is shown in Fig. 7.

The under side of the label may be coated

with an adhesive which is of a thermoplastic nature and becomes softened and adherent upon the application of heat. The label adheres to the article and the label application is complete. This is the practical form in which the invention has been developed, but it is to be understood that the invention is not necessarily limited to the thermoplastic adhesive requiring the application of heat, therefore a means of heating the presser roller. Other adhesives may be utilized which will adhere without heat application and the present invention is not to be limited solely to the use of heat affected adhesives on the labels and a heated presser roller for softening and rendering the adhesive effective.

For succeeding articles the process is repeated. The presser roller 57 is lifted when the greater radius portion of the cam 41 again comes to the roller 61, the feed of the article carrying spool or wheel is moved one step, moving the next succeeding article to the position previously occupied by that which has had the label applied thereto, and the cycle is repeated as described.

The labeled articles upon continued rotative step by step movement of the article carrying wheel reach a position where they fall by gravity therefrom and are guided by the curved chute 70 (Figs. 2 and 3) out of the machine to where they may be collected and removed.

The invention is practical and effective for the purposes for which it has been produced. While in the disclosure phials of a cylindrical form are shown as the articles to which the labels are to be applied one after another, it is evident that with some modifications in the carriers for the articles on the article carrying wheel or spool other articles may have labels applied thereto which need not necessarily be of circular cross section.

The present machine as shown is applicable to apply labels to articles which vary somewhat in cross sectional dimension, the adjustment of the roller 61 and the vertical adjustment of the label feed and severing mechanism providing for a relatively limited variation in such cross sectional size of the articles. Of course with interchangeable wheels for carrying the articles having a different number of rollers 23 with a different number of pins 24 and with interchangeable disks 27 to correspond therewith a single machine may be used for labeling articles of still greater variation in sizes.

The invention is defined in the appended claims and is to be considered comprehensive of all forms of structure coming within their scope.

I claim:

1. In a labeling machine attachment adapted to be placed in conjunction with a label feeding and severing machine, a rotatively mounted holder for articles to be labeled comprising, a wheel spool having spaced sides and spaced rollers mounted thereon substantially equal distances apart circumferentially of and near the peripheral edges and between the sides of said spool, whereby on rotation of said spool cylindrical articles are received therein at its upper side one after another between consecutive rollers, means for rotating said spool in step by step movements with intervals of rest between said movements, each step of movement being a predetermined distance for the receiving of an article to be labeled, means for feeding and severing labels in succession from the end of a continuous strip of connected labels one for each article at the intervals between rotative movements of said ar-

article carrying spool with the advanced edge portion of each label located against the upper side of its respective article, a rotatable presser means located above and adapted to be brought against said edge portion of a label when located against the article to which it is to be applied, and means for driving said presser member to rotate the article having the label thus located and to wrap said label on said article from its advanced edge to its rear edge around the article, said article being rotatively driven by the rotatable presser member.

2. A construction containing the elements in combination defined in claim 1, said labels at the under side thereof carrying a heat affected adhesive, and means for heating the rotative presser member to supply heat to render said adhesive adherent to the article.

3. A label applying mechanism having means for directing a continuous strip of connected labels to articles to which labels are to be applied, and having means for periodically severing the end labels in succession from said strip to furnish a label to each of said articles, supporting means for carrying articles of substantially cylindrical form under said end labels, means on said supporting means for rotatively supporting said articles for rotation of the articles, rotative presser means combined with means for bringing said presser means successively against labels to be applied to successive articles, to rotate said articles upon their supporting rollers and wrap said labels around the surfaces of said articles, and means for driving said rotative presser means and for moving said article carrying means in periodic movements with intervals of rest therebetween.

4. A label furnishing mechanism substantially beneath which articles of substantially cylindrical form are moved one after another past the mechanism, means for carrying said articles in spaced relation to each other in step by step movements with intervals between said movements, spaced rollers on said carrying means upon which the articles are carried, each article upon and between two spaced rollers, means for furnishing a label to each article with the label bearing at an advanced edge portion against the article, a rotatively mounted presser drum between which and each article to be labeled said advanced edge portion of the label is located, means for moving said presser drum away from said article during the times that the articles are moved in said step by step movement and the labels furnished, means for driving and causing the continuous rotation of said presser drum, said drum moving means being released for the drum to bear against a label and the article to which the label is being applied to turn such article about its longitudinal axis and wrap the label against the curved surface thereof as specified.

5. A construction containing the elements in combination defined in claim 4, combined with an electric circuit for controlling the label furnishing mechanism, a switch in said circuit normally occupying an open position and means for closing said switch at predetermined intervals for controlling the furnishing of the labels in succession to said articles at the periods when said presser roller is moved away therefrom.

6. In a label attaching machine, a rotatable article support, means thereon to receive articles and support them for a turning movement about an axis, means for supplying a label for each of

the articles, a driving means, means for rotating said article support in periodic step by step movements with intervals of rest between movements, a rotatable presser drum to engage each label against its respective article and by its rotation turn said article about said axis and wrap the label against the surface of the article, means for driving said presser drum from said driving means, and means operated by said driving means for periodically rendering said label supplying mechanism operative to supply the labels in succession to said articles.

7. In a labeling machine, a support for cylindrical articles comprising, a rotatably mounted article support, means thereon for receiving articles to be labeled at its upper side and supporting the articles for rotative movement about the axes of said articles, means for periodically rotating said article support in time-spaced successive steps of movement at each of which an article may be supplied to said support and a label attached to an article previously supplied to the support, means for supplying labels one for each article at periodic intervals and for locating a label on an article to which it is to be applied with its advanced edge portion against the upper side of the article, a rotatable presser drum, means for mounting the drum for movement toward and away from said article supporting means, means for moving the drum away at the times that the labels are supplied to the articles, means for releasing the drum to press said label against the article to be labeled, and means for continuously rotating said drum, as specified.

8. A construction containing the elements in combination defined in claim 6, combined with electric circuit means for controlling the operation of said label supplying means, said circuit means having a make and break switch therein, and means driven by the means which drives said drum for periodically closing said circuit to render the label supplying means operative to supply labels one for each article to be labeled.

9. A construction containing the elements in combination defined in claim 6, combined with an electric circuit means for controlling the operation of said label supplying means, two switches in said circuit means, the closing of both of which completes the circuit and renders the label supplying means operative, means driven by the drum driving means for periodically closing one of said switches, and a switch closing lever included in the other of said switches which extends into the path of movement of said articles to be labeled, the successive engagements of said articles therewith closing said switch at periodic intervals, as specified.

10. In a label attaching machine, a support for substantially cylindrical articles comprising, a spool mounted to turn upon a horizontal axis, said spool having spaced apart sides and a plurality of freely rotatable rollers mounted to turn upon horizontal axes mounted on and between said sides adjacent the periphery thereof, said rollers being spaced apart around the spool and adapted to support a cylindrical article upon any two consecutive rollers disposed at the upper side of the spool, means for periodically rotating the spool in step by step movements with intervals of rest between said movements, a guiding chute for cylindrical articles located at the upper portion of and to one side of said spool down which cylindrical articles may move by gravity to be received successively upon and between adjacent rollers, means for successively furnishing labels one to

each article as it reaches a predetermined position in the rotation of said spool, a pivotally mounted frame one end of which extends toward and over a portion of said spool, a rotatably mounted presser drum carried on said frame over said article supporting spool, means for driving said drum, and means for elevating said drum a short distance during the step by step movements of the spool and for releasing said drum to move to a downward position and press against a label and the article thereunder during intervals of rest of said spool.

11. In a label attaching machine, a movable supporting means for articles to be labeled, means on said supporting means for carrying the articles

5 whereby the articles may be turned each about an axis, means for supplying a label for each article, means for pressing said label against the article, said pressing means being rotatable to thereby turn said article about said axis upon engaging and pressing the label thereagainst to conform the label to the surface of the article, a driving means, means for driving said pressing means by said driving means and means driven 10 by said driving means for periodically moving said movable article support a predetermined distance at periodic intervals with periods of rest between said movements.

HOWARD B. TUTHILL.