



US0D1034879S

(12) **United States Design Patent**
Eitschberger et al.

(10) **Patent No.:** **US D1,034,879 S**
(45) **Date of Patent:** **** Jul. 9, 2024**

(54) **GUN BODY**

FOREIGN PATENT DOCUMENTS

(71) Applicant: **DynaEnergetics Europe GmbH**,
Troisdorf (DE)

CA 288787 A 4/1929
CN 2648065 10/2004

(Continued)

(72) Inventors: **Christian Eitschberger**, Munich (DE);
Arash Shahinpour, Troisdorf (DE);
Gernot Uwe Burmeister, Austin, TX
(US); **Thilo Scharf**, Letterkenny (IE)

OTHER PUBLICATIONS

Federal Institute of Industrial Property; Inquiry for RU App. No. 2016109329/03(014605); issued Jul. 10, 2019; 7 pages (Eng. Translation 5 pages).

(Continued)

(73) Assignee: **DynaEnergetics Europe GmbH** (DE)

(**) Term: **15 Years**

Primary Examiner — Michael A. Pratt

(21) Appl. No.: **29/748,612**

(74) *Attorney, Agent, or Firm* — Womble Bond Dickinson (US) LLP

(22) Filed: **Aug. 31, 2020**

Related U.S. Application Data

(57) **CLAIM**

(63) Continuation-in-part of application No. 29/722,461, filed on Jan. 30, 2020, which is a continuation-in-part (Continued)

We claim the ornamental design of a gun body, as shown and described.

DESCRIPTION

(30) **Foreign Application Priority Data**

Jul. 29, 2020 (CN) 202030421352.0

(51) **LOC (14) Cl.** **15-03**

(52) **U.S. Cl.**
USPC **D15/21**

(58) **Field of Classification Search**
USPC D15/21; D22/112; D23/259, 262
(Continued)

FIG. 1 is an upper perspective view of a gun body showing our new design;

FIG. 2 is lower perspective view of the gun body of FIG. 1;

FIG. 3 is a front elevated view of the gun body of FIG. 1;

FIG. 4 is rear elevated view of the gun body of FIG. 1;

FIG. 5 is a left side elevated view of the gun body of FIG. 1;

FIG. 6 is a right side elevated view of the gun body of FIG. 1;

FIG. 7 is a top plan view of the gun body of FIG. 1;

FIG. 8 is a bottom plan view of the gun body of FIG. 1; and,

FIG. 9 is a cross-section view of the gun body of FIG. 7 along line 9-9.

The broken lines consisting of dashes show an environment that forms no part of the claimed design.

(56) **References Cited**

U.S. PATENT DOCUMENTS

2,216,359 A 10/1940 Spencer
2,228,873 A 1/1941 Hardt et al.

(Continued)

1 Claim, 8 Drawing Sheets

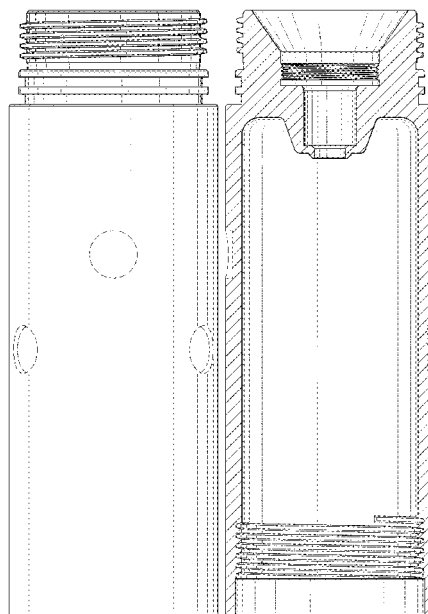

Related U.S. Application Data						
	of application No. 16/455,816, filed on Jun. 28, 2019, now Pat. No. 10,844,696, which is a continuation of application No. 16/272,326, filed on Feb. 11, 2019, now Pat. No. 10,458,213.					
(58)	Field of Classification Search					
	CPC E21B 43/11; E21B 43/112; E21B 43/114; E21B 43/116; E21B 43/117; E21B 43/119; E21B 43/00; F42D 1/04; F42D 1/05; F42D 1/043					
	See application file for complete search history.					
(56)	References Cited					
	U.S. PATENT DOCUMENTS					
	2,264,450 A	12/1941	Mounce	4,084,147 A	4/1978	Mlyniec et al.
	2,326,406 A	8/1943	Lloyd	4,085,397 A	4/1978	Yagher
	2,358,466 A	9/1944	Miller	4,100,978 A	7/1978	Boop
	2,418,486 A	4/1947	Smylie	4,107,453 A	8/1978	Erixon
	2,439,394 A	4/1948	Lanzalotti et al.	4,132,171 A	1/1979	Pawlak et al.
	2,543,814 A	3/1951	Thompson et al.	4,140,188 A	2/1979	Vann
	2,598,651 A	5/1952	Spencer	4,182,216 A	1/1980	DeCaro
	2,637,402 A	5/1953	Baker et al.	4,191,265 A	3/1980	Bosse-Platiere
	2,640,547 A	6/1953	Baker et al.	4,208,966 A	6/1980	Hart
	2,649,046 A	8/1953	Oliver	4,216,721 A	8/1980	Marziano et al.
	2,655,993 A	10/1953	Lloyd	4,220,087 A	9/1980	Posson
	2,692,023 A	10/1954	Conrad	4,261,263 A	4/1981	Coultas et al.
	2,708,408 A	5/1955	Sweetman	4,266,613 A	5/1981	Boop
	2,734,456 A	2/1956	Sweetman	4,284,235 A	8/1981	Diermayer et al.
	2,742,856 A	4/1956	Fieser et al.	4,290,486 A	9/1981	Regalbuto
	2,742,857 A	4/1956	Turechek	4,306,628 A	12/1981	Adams, Jr. et al.
	2,761,384 A	9/1956	Sweetman	4,312,273 A	1/1982	Camp
	2,766,690 A	10/1956	Lebourg	4,319,526 A	3/1982	DerMott
	2,785,631 A	3/1957	Blanchard	4,345,646 A	8/1982	Terrell
	2,873,675 A	2/1959	Lebourg	4,346,954 A	8/1982	Appling
	2,889,775 A	6/1959	Owen	4,387,773 A	6/1983	McPhee
	2,906,339 A	9/1959	Griffin	4,393,946 A	7/1983	Pottier et al.
	2,946,283 A	7/1960	Udry	4,411,491 A	10/1983	Larkin et al.
	2,982,210 A	5/1961	Andrew et al.	4,430,939 A	2/1984	Harrold
	2,996,591 A	8/1961	Thomas	4,455,941 A	6/1984	Walker et al.
	3,013,491 A	12/1961	Poulter	4,479,556 A	10/1984	Stout et al.
	3,040,659 A	6/1962	Mcculleugh	4,491,185 A	1/1985	McClure
	3,080,005 A	3/1963	Porter	4,496,008 A	1/1985	Pottier et al.
	RE25,407 E	6/1963	Lebourg	4,519,313 A	5/1985	Leidel
	3,125,024 A	3/1964	Hicks et al.	4,523,649 A	6/1985	Stout
	3,128,702 A	4/1964	Christopher	4,523,650 A	6/1985	Sehnert et al.
	3,158,680 A	11/1964	Lovitt et al.	4,534,423 A	8/1985	Regalbuto
	3,170,400 A	2/1965	Nelson	4,541,486 A	9/1985	Wetzel et al.
	RE25,846 E	8/1965	Campbell	4,574,892 A	3/1986	Grigar et al.
	3,209,692 A	10/1965	George	4,576,233 A	3/1986	George
	3,211,093 A	10/1965	Mccullough et al.	4,583,602 A	4/1986	Ayers
	3,246,707 A	4/1966	Bell	4,598,775 A	7/1986	Vann et al.
	3,264,989 A	8/1966	Rucker	4,609,057 A	9/1986	Walker et al.
	3,320,884 A	5/1967	Kowalick et al.	4,619,320 A	10/1986	Adnyana et al.
	3,327,792 A	6/1967	Boop	4,621,396 A	11/1986	Walker et al.
	3,357,355 A	12/1967	Roush	4,635,734 A	1/1987	Donovan et al.
	3,374,735 A	3/1968	Moore	4,640,354 A	2/1987	Boisson
	3,414,071 A	12/1968	Alberts	4,640,370 A	2/1987	Wetzel
	3,415,321 A	12/1968	Venghiattis	4,643,097 A	2/1987	Chawla et al.
	3,504,723 A	4/1970	Cushman et al.	4,650,009 A	3/1987	McClure et al.
	3,565,188 A	2/1971	Hakala	4,657,089 A	4/1987	Stout
	3,621,916 A	11/1971	Smith, Jr.	4,660,910 A	4/1987	Sharp et al.
	3,650,212 A	3/1972	Bauer	4,676,528 A	6/1987	Gray
	3,659,658 A	5/1972	Brieger	4,747,201 A	5/1988	Donovan et al.
	3,731,626 A	5/1973	Grayson	4,753,170 A	6/1988	Regalbuto et al.
	3,859,921 A	1/1975	Stephenson	4,756,363 A	7/1988	Lanmon et al.
	3,892,455 A	7/1975	Sotolongo	4,762,067 A	8/1988	Barker et al.
	4,007,790 A	2/1977	Henning	4,766,813 A	8/1988	Winter et al.
	4,007,796 A	2/1977	Boop	4,776,393 A	10/1988	Forehand et al.
	4,024,817 A	5/1977	Calder, Jr. et al.	4,790,383 A	12/1988	Savage et al.
	4,034,673 A	7/1977	Schneider, Jr.	4,796,708 A	1/1989	Lembcke
	4,058,061 A	11/1977	Mansur, Jr. et al.	4,800,815 A	1/1989	Appledorn et al.
	4,071,096 A	1/1978	Dines	4,817,531 A	4/1989	Walker et al.
	4,080,898 A	3/1978	Gieske	4,832,134 A	5/1989	Gill
	4,080,902 A	3/1978	Goddard et al.	4,850,438 A	7/1989	Regalbuto
				4,869,171 A	9/1989	Abouav
				4,884,506 A	12/1989	Guerreri
				4,889,183 A	12/1989	Sommers et al.
				4,998,478 A	3/1991	Beck
				5,001,981 A	3/1991	Shaw
				5,010,821 A	4/1991	Blain
				5,027,708 A	7/1991	Gonzalez et al.
				5,038,682 A	8/1991	Marsden
				5,052,489 A	10/1991	Carisella et al.
				5,060,573 A	10/1991	Montgomery et al.
				5,070,788 A	12/1991	Carisella et al.
				5,083,929 A	1/1992	Dalton
				5,088,413 A	2/1992	Huber
				5,090,324 A	2/1992	Bocker et al.
				5,105,742 A	4/1992	Sumner
				5,119,729 A	6/1992	Nguyen
				5,155,296 A	10/1992	Michaluk
				5,159,145 A	10/1992	Carisella et al.
				5,165,489 A	11/1992	Langston

(56)

References Cited

U.S. PATENT DOCUMENTS

5,204,491	A	4/1993	Aureal et al.	7,404,725	B2	7/2008	Hall et al.	
5,216,197	A	6/1993	Huber et al.	7,441,601	B2	10/2008	George et al.	
5,223,664	A	6/1993	Rogers	7,481,662	B1	1/2009	Rehrig	
5,322,019	A	6/1994	Hyland	7,553,078	B2	6/2009	Hanzawa et al.	
5,347,929	A	9/1994	Lerche et al.	7,568,429	B2	8/2009	Hummel et al.	
5,366,013	A	11/1994	Edwards et al.	7,661,366	B2	2/2010	Fuller et al.	
5,392,851	A	2/1995	Arend	7,661,474	B2*	2/2010	Campbell	E21B 43/116
5,392,860	A	2/1995	Ross					166/242.6
5,436,791	A	7/1995	Turano et al.	7,726,396	B2	6/2010	Briquet et al.	
5,479,860	A	1/1996	Ellis	7,735,578	B2	6/2010	Loehr et al.	
5,490,563	A	2/1996	Wesson et al.	7,748,447	B2	7/2010	Moore	
5,503,077	A	4/1996	Motley	7,752,971	B2	7/2010	Loehr	
5,529,509	A	6/1996	Hayes et al.	7,762,172	B2	7/2010	Li et al.	
5,540,154	A	7/1996	Wilcox et al.	7,762,351	B2	7/2010	Vidal	
5,551,346	A	9/1996	Walters et al.	7,778,006	B2	8/2010	Stewart et al.	
5,551,520	A	9/1996	Bethel et al.	7,810,430	B2	10/2010	Chan et al.	
5,558,531	A	9/1996	Ikeda et al.	7,823,508	B2	11/2010	Anderson et al.	
5,571,986	A	11/1996	Snider et al.	7,901,247	B2	3/2011	Ring	
5,603,384	A	2/1997	Bethel et al.	7,908,970	B1	3/2011	Jakaboski et al.	
5,648,635	A	7/1997	Lussier et al.	7,929,270	B2	4/2011	Hummel et al.	
5,703,319	A	12/1997	Fritz et al.	7,934,453	B2	5/2011	Moore	
5,756,926	A	5/1998	Bonbrake et al.	7,952,035	B2	5/2011	Falk et al.	
5,759,056	A	6/1998	Costello et al.	7,980,874	B2	7/2011	Finke et al.	
5,765,962	A	6/1998	Cornell et al.	8,066,083	B2	11/2011	Hales et al.	
5,769,661	A	6/1998	Nealis	8,069,789	B2	12/2011	Hummel et al.	
5,775,426	A	7/1998	Snider et al.	8,074,737	B2	12/2011	Hill et al.	
5,785,130	A	7/1998	Wesson et al.	8,079,296	B2	12/2011	Barton et al.	
5,803,175	A	9/1998	Myers, Jr. et al.	8,127,846	B2	3/2012	Hill et al.	
5,816,343	A	10/1998	Markel et al.	8,157,022	B2	4/2012	Bertoja et al.	
5,837,925	A	11/1998	Nice	8,181,718	B2	5/2012	Burleson et al.	
5,859,383	A	1/1999	Davison et al.	8,182,212	B2	5/2012	Parcell	
5,992,289	A	11/1999	George et al.	8,186,259	B2	5/2012	Burleson et al.	
6,006,833	A	12/1999	Burleson et al.	8,256,337	B2	9/2012	Hill	
6,012,525	A	1/2000	Burleson et al.	8,297,345	B2	10/2012	Emerson	
6,050,353	A	4/2000	Logan et al.	8,327,746	B2	12/2012	Behrmann et al.	
6,062,310	A	5/2000	Wesson et al.	8,336,635	B2	12/2012	Greenlee et al.	
6,085,659	A	7/2000	Beukes et al.	8,388,374	B2	3/2013	Grek et al.	
6,112,666	A	9/2000	Murray et al.	8,388,374	B2	3/2013	Stewart et al.	
6,158,532	A	12/2000	Logan et al.	8,395,878	B2	3/2013	Stewart et al.	
6,295,912	B1	10/2001	Burleson et al.	8,408,286	B2	4/2013	Rodgers et al.	
6,297,447	B1	10/2001	Burnett et al.	D682,384	S	5/2013	Jaureguizar	
6,298,915	B1	10/2001	George	8,449,308	B2	5/2013	Smith	
6,305,287	B1	10/2001	Capers et al.	8,468,944	B2	6/2013	Givens et al.	
6,354,374	B1	3/2002	Edwards et al.	8,490,686	B2	7/2013	Rodgers et al.	
6,386,108	B1	5/2002	Brooks et al.	8,661,978	B2	3/2014	Backhus et al.	
6,408,758	B1	6/2002	Duguet	8,695,506	B2	4/2014	Lanclos	
6,412,415	B1	7/2002	Kothari et al.	8,726,996	B2	5/2014	Busaidy et al.	
6,418,853	B1	7/2002	Duguet et al.	D712,013	S *	8/2014	Mather	D23/259
6,439,121	B1	8/2002	Gillingham	8,863,665	B2	10/2014	DeVries et al.	
6,467,415	B2	10/2002	Menzel et al.	8,869,887	B2	10/2014	Deere et al.	
6,487,973	B1	12/2002	Gilbert, Jr. et al.	8,875,787	B2	11/2014	Tassaroli	
6,497,285	B2	12/2002	Walker	8,881,816	B2	11/2014	Glenn et al.	
6,508,176	B1	1/2003	Badger et al.	8,881,836	B2	11/2014	Ingram	
6,618,237	B2	9/2003	Eddy et al.	8,904,935	B1	12/2014	Brown et al.	
6,651,747	B2	11/2003	Chen et al.	8,960,093	B2	2/2015	Preiss et al.	
6,675,896	B2	1/2004	George	8,960,288	B2	2/2015	Sampson	
6,739,265	B1	5/2004	Badger et al.	8,985,023	B2	3/2015	Mason	
6,742,602	B2	6/2004	Trotechaud	8,997,852	B1	4/2015	Lee et al.	
6,752,083	B1	6/2004	Lerche et al.	9,133,695	B2	9/2015	Xu	
6,772,868	B2	8/2004	Warner	9,145,764	B2	9/2015	Burton et al.	
6,843,317	B2	1/2005	Mackenzie	9,175,553	B2	11/2015	Mccann et al.	
6,851,471	B2	2/2005	Barlow et al.	9,181,790	B2	11/2015	Mace et al.	
6,976,857	B1	12/2005	Shukla et al.	9,194,219	B1	11/2015	Hardesty et al.	
7,107,908	B2	9/2006	Forman et al.	9,270,051	B1	2/2016	Christiansen et al.	
7,182,611	B2	2/2007	Borden et al.	9,284,819	B2	3/2016	Tolman et al.	
7,193,527	B2	3/2007	Hall	9,382,783	B2	7/2016	Langford et al.	
7,237,626	B2*	7/2007	Gurjar	9,441,465	B2	9/2016	Tassaroli	
			E21B 17/028	9,466,916	B2	10/2016	Li et al.	
			175/320	9,476,289	B2	10/2016	Wells	
7,255,183	B2	8/2007	Cramer	9,494,021	B2	11/2016	Parks et al.	
7,278,491	B2	10/2007	Scott	9,574,416	B2	2/2017	Wright et al.	
7,347,278	B2	3/2008	Lerche et al.	9,581,422	B2	2/2017	Preiss et al.	
7,347,279	B2	3/2008	Li et al.	9,598,942	B2	3/2017	Wells et al.	
7,350,448	B2	4/2008	Bell et al.	9,605,937	B2	3/2017	Eitschberger et al.	
7,357,083	B2	4/2008	Takahara et al.	D783,133	S	4/2017	Fitzhugh et al.	
7,364,451	B2	4/2008	Ring et al.	9,677,363	B2	6/2017	Schacherer et al.	
				9,689,223	B2	6/2017	Schacherer et al.	
				9,702,680	B2	7/2017	Parks et al.	
				9,709,373	B2	7/2017	Hikone et al.	
				9,784,549	B2	10/2017	Eitschberger	

(56)		References Cited	
U.S. PATENT DOCUMENTS			
9,822,618	B2	11/2017	Eitschberger
D807,991	S *	1/2018	Fitzhugh D15/21
9,903,192	B2	2/2018	Entchev et al.
9,926,750	B2	3/2018	Ringgenberg
9,926,755	B2	3/2018	Van Petegem et al.
10,000,994	B1	6/2018	Sites
10,066,921	B2	9/2018	Eitschberger
10,077,641	B2	9/2018	Rogman et al.
10,138,713	B2	11/2018	Tolman et al.
10,151,152	B2	12/2018	Wight et al.
10,151,180	B2	12/2018	Robey et al.
10,188,990	B2	1/2019	Burmeister et al.
10,190,398	B2	1/2019	Goodman et al.
10,273,788	B2	4/2019	Bradley et al.
10,309,199	B2	6/2019	Eitschberger
10,337,270	B2	7/2019	Carisella et al.
10,352,136	B2	7/2019	Goyeneche
10,352,144	B2	7/2019	Entchev et al.
10,385,629	B2	8/2019	Spence et al.
10,458,213	B1	10/2019	Eitschberger et al.
10,472,938	B2	11/2019	Parks et al.
10,597,979	B1 *	3/2020	Eitschberger G01R 27/18
10,669,822	B2	6/2020	Eitschberger
10,689,931	B2	6/2020	Mickey et al.
D892,278	S *	8/2020	Eitschberger D23/262
10,794,159	B2 *	10/2020	Eitschberger E21B 23/10
10,844,696	B2	11/2020	Eitschberger et al.
D904,475	S	12/2020	Preiss
10,900,335	B2	1/2021	Knight et al.
10,920,543	B2	2/2021	Eitschberger
D921,858	S *	6/2021	Eitschberger D23/262
11,021,923	B2 *	6/2021	Mulhern E21B 23/0414
11,215,041	B2	1/2022	Knight et al.
11,480,038	B2 *	10/2022	Eitschberger E21B 43/1185
D968,474	S *	11/2022	Volberg D15/21
11,591,885	B2 *	2/2023	Eitschberger E21B 43/1185
2002/0020320	A1	2/2002	Lebaudy et al.
2002/0062991	A1	5/2002	Farrant et al.
2003/0000411	A1	1/2003	Cernocky et al.
2003/0001753	A1	1/2003	Cernocky et al.
2004/0141279	A1	7/2004	Amano et al.
2005/0178282	A1	8/2005	Brooks et al.
2005/0183610	A1	8/2005	Barton et al.
2005/0186823	A1	8/2005	Ring et al.
2005/0194146	A1	9/2005	Barker et al.
2005/0229805	A1	10/2005	Myers, Jr. et al.
2005/0279513	A1	12/2005	Eppink
2006/0013282	A1	1/2006	Hanzawa et al.
2007/0084336	A1	4/2007	Neves
2007/0125540	A1	6/2007	Gerez et al.
2007/0158071	A1	7/2007	Mooney, Jr. et al.
2008/0047456	A1	2/2008	Li et al.
2008/0047716	A1	2/2008	McKee et al.
2008/0110612	A1	5/2008	Prinz et al.
2008/0121095	A1	5/2008	Han et al.
2008/0134922	A1	6/2008	Grattan et al.
2008/0149338	A1	6/2008	Goodman et al.
2008/0173204	A1	7/2008	Anderson et al.
2008/0173240	A1	7/2008	Furukawahara et al.
2008/0264639	A1	10/2008	Parrott et al.
2009/0050322	A1	2/2009	Hill et al.
2009/0159283	A1	6/2009	Fuller et al.
2009/0272519	A1	11/2009	Green et al.
2009/0272529	A1	11/2009	Crawford
2009/0301723	A1	12/2009	Gray
2010/0000789	A1	1/2010	Barton et al.
2010/0089643	A1	4/2010	Vidal
2010/0096131	A1	4/2010	Hill et al.
2010/0163224	A1	7/2010	Strickland
2010/0230104	A1	9/2010	Nölke et al.
2010/0286800	A1	11/2010	Lerche et al.
2010/0300750	A1	12/2010	Hales et al.
2011/0024116	A1	2/2011	McCann et al.
2011/0042069	A1	2/2011	Bailey et al.
2012/0085538	A1	4/2012	Guerrero et al.
2012/0094553	A1	4/2012	Fujiwara et al.
2012/0160491	A1	6/2012	Goodman et al.
2012/0199031	A1	8/2012	Lanclos
2012/0199352	A1	8/2012	Lanclos et al.
2012/0241169	A1	9/2012	Hales et al.
2012/0242135	A1	9/2012	Thomson et al.
2012/0247769	A1	10/2012	Schacherer et al.
2012/0247771	A1	10/2012	Black et al.
2012/0298361	A1	11/2012	Sampson
2013/0008639	A1	1/2013	Tassaroli et al.
2013/0062055	A1	3/2013	Tolman et al.
2013/0118342	A1	5/2013	Tassaroli
2013/0199843	A1	8/2013	Ross
2013/0248174	A1	9/2013	Dale et al.
2014/0000877	A1	1/2014	Robertson et al.
2014/0033939	A1	2/2014	Priess et al.
2014/0131035	A1	5/2014	Entchev et al.
2014/0144702	A1	5/2014	Walker
2015/0136419	A1	5/2015	Mauldin
2015/0176386	A1	6/2015	Castillo et al.
2015/0226044	A1	8/2015	Ursi et al.
2015/0330192	A1	11/2015	Rogman et al.
2015/0376991	A1	12/2015	Mcnelis et al.
2016/0040520	A1	2/2016	Tolman et al.
2016/0061572	A1	3/2016	Eitschberger et al.
2016/0069163	A1	3/2016	Tolman et al.
2016/0084048	A1	3/2016	Harrigan et al.
2016/0168961	A1	6/2016	Parks et al.
2016/0273902	A1	9/2016	Eitschberger
2016/0281466	A1	9/2016	Richards
2016/0356132	A1	12/2016	Burmeister et al.
2017/0028437	A1	2/2017	Holly et al.
2017/0030693	A1	2/2017	Preiss et al.
2017/0052011	A1	2/2017	Parks et al.
2017/0058649	A1	3/2017	Geerts et al.
2017/0074078	A1	3/2017	Eitschberger
2017/0138150	A1	5/2017	Yencho
2017/0145798	A1	5/2017	Robey et al.
2017/0167233	A1	6/2017	Sampson et al.
2017/0175498	A1	6/2017	Segura
2017/0199015	A1	7/2017	Collins et al.
2017/0211363	A1	7/2017	Bradley et al.
2017/0241244	A1	8/2017	Barker et al.
2017/0268860	A1	9/2017	Eitschberger
2017/0276465	A1	9/2017	Parks et al.
2017/0314372	A1	11/2017	Tolman et al.
2017/0314373	A9	11/2017	Bradley et al.
2018/0030334	A1	2/2018	Collier et al.
2018/0038208	A1	2/2018	Eitschberger et al.
2018/0094910	A1	4/2018	Ashton et al.
2018/0135398	A1	5/2018	Entchev et al.
2018/0202789	A1	7/2018	Parks et al.
2018/0202790	A1	7/2018	Parks et al.
2018/0209250	A1	7/2018	Daly et al.
2018/0209251	A1	7/2018	Robey et al.
2018/0274342	A1	9/2018	Sites
2018/0299239	A1	10/2018	Eitschberger et al.
2018/0306010	A1	10/2018	Von Kaenel et al.
2018/0318770	A1	11/2018	Eitschberger et al.
2018/0347324	A1	12/2018	Langford et al.
2019/0032470	A1	1/2019	Harrigan
2019/0040722	A1	2/2019	Yang et al.
2019/0048693	A1	2/2019	Henke et al.
2019/0049225	A1	2/2019	Eitschberger
2019/0085685	A1	3/2019	McBride
2019/0153827	A1 *	5/2019	Goyeneche E21B 17/02
2019/0162055	A1	5/2019	Collins et al.
2019/0162056	A1	5/2019	Sansing
2019/0195054	A1	6/2019	Bradley et al.
2019/0211655	A1	7/2019	Bradley et al.
2019/0219375	A1	7/2019	Parks et al.
2019/0234188	A1	8/2019	Goyeneche
2019/0242222	A1	8/2019	Eitschberger
2019/0257181	A1	8/2019	Langford et al.
2019/0284889	A1	9/2019	LaGrange et al.
2019/0292887	A1	9/2019	Austin, II et al.
2019/0309606	A1	10/2019	Loehken et al.
2019/0316449	A1	10/2019	Schultz et al.
2019/0330961	A1	10/2019	Knight et al.

(56)

References Cited

U.S. PATENT DOCUMENTS

2019/0338612	A1	11/2019	Holodnak et al.
2019/0353013	A1	11/2019	Sokolove et al.
2020/0024934	A1	1/2020	Eitschberger et al.
2020/0024935	A1	1/2020	Eitschberger et al.
2020/0032626	A1	1/2020	Parks et al.
2020/0063537	A1	2/2020	Langford et al.
2020/0217635	A1	7/2020	Eitschberger
2020/0248536	A1	8/2020	Holodnak et al.
2020/0256168	A1	8/2020	Knight et al.
2020/0284104	A1	9/2020	Holmberg et al.
2020/0392821	A1	12/2020	Eitschberger et al.
2021/0172298	A1	6/2021	Knight et al.
2022/0178230	A1*	6/2022	Eitschberger E21B 43/1185
2022/0307330	A1*	9/2022	Eitschberger E21B 17/0423
2022/0403718	A1*	12/2022	Eitschberger E21B 43/26
2023/0016759	A1*	1/2023	Eitschberger E21B 17/043

FOREIGN PATENT DOCUMENTS

EP	0160449	A1	11/1985
WO	1988002056	A1	3/1988
WO	1999005390	A1	2/1999
WO	2001096807	A2	12/2001
WO	2014046670	A1	3/2014
WO	2015006869	A1	1/2015
WO	2015028204	A2	3/2015
WO	2015102620	A1	7/2015
WO	2015134719	A1	9/2015
WO	2018009223	A1	1/2018
WO	2018026952	A1	2/2018
WO	2019117861	A1	6/2019
WO	2019148009	A2	8/2019
WO	2019204137	A1	10/2019
WO	2020200935	A1	10/2020
WO	2020232242	A1	11/2020
WO	2020249744	A2	12/2020

OTHER PUBLICATIONS

Federal Institute of Industrial Property; Inquiry for RU Application No. 2016110014/03(015803); issued Feb. 1, 2018; 6 pages (Eng. Translation 4 pages).

GB Intellectual Property Office, Combined Search and Examination Report for GB App. No. 1717516.7, dated Feb. 27, 2018, 6 pgs.

GB Intellectual Property Office, Combined Search and Examination Report for GB App. No. GB1700625.5, dated Jul. 7, 2017, 5 pages.

GB Intellectual Property Office, Examination Report for GB App. No. GB1600085.3, mailed Mar. 9, 2016, 1 pg.

GB Intellectual Property Office, Search Report for App. No. GB 1700625.5; dated Jul. 7, 2017; 5 pgs.

GB Intellectual Property Office; Examination Report for GB Appl. No. 1717516.7; Apr. 13, 2018; 3 pages.

GB Intellectual Property Office; Notification of Grant for GB Appl. No. 1717516.7; Oct. 9, 2018; 2 pages.

GB Intellectual Property Office; Office Action for GB App. No. 1717516.7; dated Feb. 27, 2018; 6 pages.

GB Intellectual Property Office; Search Report for GB. Appl. No. 1700625.5; mailed Dec. 21, 2017; 5 pages.

GeoDynamics; "Vapri"; promotional brochure; Oct. 1, 2019.

German Patent Office, Office Action for German Patent Application No. 10 2013 109 227.6, which is in the same family as PCT Application No. PCT/EP2014/065752, see p. 5 for references cited, May 22, 2014, 8 pgs.

Gilliat et al.; New Select-Fire System: Improved Reliability and Safety in Select Fire Operations; 2012; 16 pgs.

Horizontal Wireline Services, Presentation of a completion method of shale demonstrated through an example of Marcellus Shale, Pennsylvania, USA, Presented at 2012 International Perforating Symposium (Apr. 26-28, 2012), 17 pages.

Hunting Energy Service, ControlFire RF Safe ControlFire® RF-Safe Manual, 33 pgs., Jul. 2016, http://www.hunting-intl.com/media/2667160/ControlFire%20RF_Assembly%20Gun%20Loading_Manual.pdf.

Hunting Energy Services Pte Ltd., "H-1 Perforating Gun System"; promotional brochure; Jun. 21, 2019.

Hunting Titan Inc.; Petition for Post Grant Review of U.S. Pat. No. 10,429,161; dated Jun. 30, 2020; 109 pages.

Hunting Titan Ltd.; Petition for Inter Partes Review of U.S. Pat. No. 9,581,422 Case No. IPR2018-00600; dated Feb. 16, 2018; 93 pages.

Hunting Titan Ltd.; Defendants' Answer to First Amended Complaint and Counterclaims, Civil Action No. 6:20-cv-00069; dated Apr. 6, 2020; 30 pages.

Hunting Titan Ltd.; Defendants' Answer to Second Amended Complaint and Counterclaims, Civil Action No. 6:20-cv-00069; dated May 12, 2020; 81 pages.

Hunting Titan Ltd.; Defendants Invalidation Contentions Pursuant to Patent Rule 3-3, Civil Action No. 4:17-cv-03784; dated Jul. 6, 2018; 29 pages.

Hunting Titan Ltd.; Defendants' Objections and Responses to Plaintiffs' First Set of Interrogatories, Civil Action No. 4:17-cv-03784; dated Jun. 11, 2018.

Hunting Titan Ltd.; Defendants' Opposition to Plaintiffs' Motion to Dismiss and Strike Defendants' Amended Counterclaim and Affirmative Defenses for Unenforceability due to Inequitable Conduct for Civil Action No. 4:17-cv-03784; dated Apr. 24, 2018; 8 pages.

Hunting Titan, H-1 Perforating System, Sep. 1, 2017, 3 pgs., <http://www.hunting-intl.com/titan/perforating-guns-and-setting-tools/h-1%C2%AE-perforating-system>.

Hunting Titan, H-1® Perforating Gun System, 2016, 2 pgs., <http://www.hunting-intl.com/titan>.

Hunting Titan, Inc., U.S. Appl. No. 62/621,999 titled Cluster Gun System and filed Jan. 25, 2018, which is a priority application of International App. No. PCT/US2019/015255 published as WO2019/148009, Aug. 1, 2019, 7 pages, WIPO.

Hunting Titan, Inc., U.S. Appl. No. 62/627,591 titled Cluster Gun System and filed Feb. 7, 2018, which is a priority application of International App. No. PCT/US2019/015255 published as WO2019/148009, Aug. 1, 2019, 7 pages, WIPO.

Hunting Titan, Inc., U.S. Appl. No. 62/736,298 titled Starburst Cluster Gun and filed Sep. 25, 2018, which is a priority application of International App. No. PCT/US2019/015255 published as International Publication No. WO2019/148009, Aug. 1, 2019, 34 pages, WIPO.

Hunting Titan, Wireline Top Fire Detonator Systems, Nov. 24, 2014, 2 pgs, <http://www.hunting-intl.com/titan/perforating-guns-and-setting-tools/wireline-top-fire-detonator-systems>.

Hunting Titan; ControlFire RF-Safe Assembly Gun Loading Manual; 33 pages.

Industrial Property Office, Czech Republic; Office Action; CZ App. No. PV 2017-675; Dec. 17, 2018; 2 pages.

Instituto Nacional De La Propiedad Industrial; Office Action for AR Appl. No. 20140102653; issued May 9, 2019 (1 page).

Intellectual Property India, Office Action of IN Application No. 201647004496, dated Jun. 7, 2019, 6 pgs.

International Searching Authority, International Search Report and Written Opinion for PCT App. No. PCT/IB2019/000569; Oct. 9, 2019, 12 pages.

International Searching Authority, International Search Report and Written Opinion of International App. No. PCT/IB2019/000569, mailed Oct. 9, 2019, 12 pages.

International Searching Authority; International Preliminary Report on Patentability for PCT Appl. No. PCT/CA2014/050673; issued Jan. 19, 2016; 5 pages.

International Searching Authority; International Search Report and Written Opinion for PCT App. No. PCT/CA2014/050673; mailed Oct. 9, 2014; 7 pages.

International Searching Authority; International Search Report and Written Opinion for PCT App. No. PCT/EP2015/059381; Nov. 23, 2015; 14 pages.

International Searching Authority; International Search Report and Written Opinion for PCT App. No. PCT/EP2019/069165; Oct. 22, 2019; 13 pages.

(56)

References Cited

OTHER PUBLICATIONS

International Searching Authority; International Search Report and Written Opinion for PCT App. No. PCT/US2015/018906; Jul. 10, 2015; 12 pages.

Jet Research Center Inc., JRC Catalog, 2008, 36 pgs., https://www.jetresearch.com/content/dam/jrc/Documents/Books_Catalogs/06_Dets.pdf.

Jet Research Center, Velocity™ Perforating System Plug and Play Guns For Pumpdown Operation, Ivarado, Texas, Jul. 2019, 8 pgs., <https://www.jetresearch.com/content/dam/jrc/Documents/Brochures/jrc-velocity-perforating-system.pdf>.

McNelis et al.; High-Performance Plug-and-Perf Completions in Unconventional Wells; Society of Petroleum Engineers Annual Technical Conference and Exhibition; Sep. 28, 2015.

Norwegian Industrial Property Office; Office Action and Search Report for NO App. No. 20160017; Jun. 15, 2017; 5 pages.

Norwegian Industrial Property Office; Office Action and Search Report for NO App. No. 20171759; Jan. 14, 2020; 6 pages.

Norwegian Industrial Property Office; Office Action for NO Appl. No. 20160017; mailed Dec. 4, 2017; 2 pages.

Norwegian Industrial Property Office; Office Action for NO Appl. No. 20171759; mailed Oct. 30, 2020; 2 pages.

Norwegian Industrial Property Office; Opinion for NO Appl. No. 20171759; mailed Apr. 5, 2019; 1 page.

OSO Perforating; "OsoLite"; promotional brochure; Jan. 2019.

Owen Oil Tools & Pacific Scientific; RF-Safe Green Det, Side Block for Side Initiation, Jul. 26, 2017, 2 pgs.

Amit Govil, Selective Perforation: A Game Changer in Perforating Technology—Case Study, presented at the 2012 European and West African Perforating Symposium, Schlumberger, Nov. 7-9, 2012, 14 pgs.

Austin Powder Company; A-140 F & Block, Detonator & Block Assembly; Jan. 5, 2017; 2 pgs.; https://www.austinpowder.com/wp-content/uploads/2019/01/OilStar_A140Fbk-2.pdf.

Baker Hughes, Long Gun Deployment Systems IPS-12-28; 2012 International Perforating Symposium; Apr. 26-27, 2011; 11 pages. Baker Hughes; SurePerf Rapid Select-Fire System Perforate production zones in a single run; 2012; 2 pages.

Brazilian Patent and Trademark Office; Search Report for BR Application No. BR112015033010-0; mailed May 5, 2020; (4 pages).

Burndy, Bulkhead Ground Connector, Mechanical Summary Sheet, The Grounding Superstore, Jul. 15, 2014, 1 page, <https://www.burndy.com/docs/default-source/cutsheets/bulkhead-connect>.

Canadian Intellectual Property Office, Office Action for CA App. No. 2923860 dated Jul. 14, 2017, 3 pages.

Canadian Intellectual Property Office, Office Action for CA App. No. 2923860 dated Nov. 25, 2016, 3 pages.

Canadian Intellectual Property Office; First Office Action for CA App. No. 2933756; Issued May 25, 2017; 2 pages.

Canadian Intellectual Property Office; Fourth Office Action for CA App. No. 2933756; Issued May 31, 2019; 3 pages.

Canadian Intellectual Property Office; Notice of Allowance for CA Appl. No. 2,821,506; mailed Jul. 31, 2019; 1 page.

Canadian Intellectual Property Office; Office Action for CA Appl. No. 2,821,506; mailed Mar. 21, 2019; 4 pages.

Canadian Intellectual Property Office; Second Office Action for CA App. No. 2933756; Issued Jan. 29, 2018; 3 pages.

Canadian Intellectual Property Office; Third Office Action for CA App. No. 2933756; Issued Jul. 31, 2018; 2 pages.

Core Lab, ZERO180™ Gun System Assembly and Arming Procedures, 2015, 33 pgs., <https://www.corelab.com/owen/CMS/docs/Manuals/gunsys/zero180/MAN-Z180-000.pdf>.

DynaEnergetics Europe; Complaint and Demand for Jury Trial, Civil Action No. 1:20-cv-03665; dated Dec. 15, 2020; 8 pages.

DynaEnergetics Europe; Complaint and Demand for Jury Trial, Civil Action No. 6:20-cv-00069; dated Jan. 30, 2020; 9 pages.

DynaEnergetics Europe; Complaint and Demand for Jury Trial, Civil Action No. 4:17-cv-03784; dated Dec. 14, 2017; 7 pages.

DynaEnergetics Europe; Exhibit B Invalidity Claim Chart for Civil Action No. 4:19-cv-01611; dated May 2, 2019; 52 pages.

DynaEnergetics Europe; Exhibit C Invalidity Claim Chart for Civil Action No. 4:17-cv-03784; dated Jul. 13, 2020; 114 pages.

DynaEnergetics Europe; Plaintiffs' Local Patent Rule 3-1 Infringement Contentions for Civil Action No. 4:19-cv-01611; dated May 25, 2018; 10 Pages.

DynaEnergetics Europe; Plaintiffs' Motion to Dismiss Defendants' Counterclaim and to strike Affirmative Defenses, Civil Action No. 4:17-cv-03784; dated Feb. 20, 2018; 9 pages.

DynaEnergetics Europe; Plaintiffs' Preliminary Claim Constructions and Identification of Extrinsic Evidence Civil Action No. 4:17-cv-03784; dated Aug. 3, 2018; 9 pages.

DynaEnergetics Europe; Plaintiffs' Reply in Support of Motion to Dismiss and Strike for Civil Action No. 6:20-cv-00069-ADA; dated Apr. 29, 2020; 15 pages.

DynaEnergetics Europe; Plaintiffs Response to Defendant Hunting Titan Ins' Inoperative First Amended Answer, Affirmative Defenses, and Counterclaims for Civil Action No. 6:20-cv-00069-ADA; dated May 13, 2020.

DynaEnergetics Europe; Plaintiffs' Response to Defendants' Answer to Second Amended Complaint Civil Action No. 6:20-cv-00069-ADA; dated May 26, 2020; 18 pages.

DynaEnergetics GmbH & Co. KG, Patent Owner's Response to Hunting Titan's Petition for Inter Parties Review—Case IPR2018-00600, filed Dec. 6, 2018, 73 pages.

DynaEnergetics GmbH & Co. KG; Patent Owner's Precedential Opinion Panel Request for Case IPR2018-00600; Sep. 18, 2019, 2 pg.

DynaEnergetics, DYNAslect Electronic Detonator 0015 SFDE RDX 1.4B, Product Information, Dec. 16, 2011, 1 pg.

DynaEnergetics, DYNAslect Electronic Detonator 0015 SFDE RDX 1.4S, Product Information, Dec. 16, 2011, 1 pg.

DynaEnergetics, DYNAslect System, information downloaded from website, Jul. 3, 2013, 2 pages, <http://www.dynaenergetics.com/>.

DynaEnergetics, Electronic Top Fire Detonator, Product Information Sheet, Jul. 30, 2013, 1 pg.

DynaEnergetics, Gun Assembly, Product Summary Sheet, May 7, 2004, 1 page.

DynaEnergetics, Selective Perforating Switch, information downloaded from website, Jul. 3, 2013, 2 pages, <http://www.dynaenergetics.com/>.

DynaEnergetics, Selective Perforating Switch, Product Information Sheet, May 27, 2011, 1 pg.

DynaEnergetics, Through Wire Grounded Bulkhead (DynaTWG), May 25, 2016, 1 pg., https://www.dynaenergetics.com/uploads/files/5756f884e289a_U233%20DynaTWG%20Bulkhead.pdf.

DynaEnergetics; DynaStage Solution—Factory Assembled Performance-Assured Perforating Systems; 6 pages.

Entchev et al., Autonomous Perforating System for Multizone Completions, SPE International, 2011, 7 pgs., <https://www.onepetro.org/conference-paper/SPE-147296-MS>.

EP Patent Office—International Searching Authority, PCT Search Report and Written Opinion for PCT Application No. PCT/EP2014/065752, mailed May 4, 2015, 12 pgs.

Eric H. Findlay, Jury Trial Demand in Civil Action No. 6:20-cv-00069-ADA, dated Apr. 22, 2020, 32 pages.

European Patent Office; First Office Action for EP App. No. 15796416.4; Issued Nov. 4, 2016; 2 pages.

European Patent Office; Invitation to Correct Deficiencies noted in the Written Opinion for European App. No. 15721178.0; issued Dec. 13, 2016; 2 pages.

European Patent Office; Office Action for EP App. No. 15721178.0; issued Sep. 6, 2018; 5 pages.

European Patent Office; Second Office Action for EP App. No. 15796416.4; Issued Sep. 26, 2017; 4 pages.

European Patent Office; Third Office Action for EP App. No. 15796416.4; Issued Jul. 19, 2018; 3 pages.

Federal Institute of Industrial Property; Decision of Granting for RU Appl. No. 2016104882/03(007851); May 17, 2018; 15 pages (English translation 4 pages).

Federal Institute of Industrial Property; Decision on Granting a Patent for Invention Russian App. No. 2016139136/03(062394);

(56)

References Cited

OTHER PUBLICATIONS

issued Nov. 8, 2018; 20 pages (Eng Translation 4 pages); Concise Statement of Relevance: Search Report at 17-18 of Russian-language document lists several 'A' references based on RU application claims.

Federal Institute of Industrial Property; Decision on Granting for RU Application No. 2016109329/03; dated Oct. 21, 2019; 11 pages (English translation 4 pages).

Federal Institute of Industrial Property; Decision on Granting for RU Application No. 2019137475/03; dated May 12, 2020; 15 pages (English translation 4 pages).

Federal Institute of Industrial Property; Inquiry for RU App. No. 2016104882/03(007851); dated Feb. 1, 2018; 7 pages, English Translation 4 pages.

International Searching Authority; International Search Report and Written Opinion of the International Searching Authority for PCT/EP2021/079019; mailed on Feb. 28, 2022; 14 pages.

United States Patent and Trademark Office; Non-Final Office Action for U.S. Appl. No. 17/162,579; dated Feb. 28, 2022; 16 pages.

Salt Warren et al.; New Perforating Gun System Increases Safety and Efficiency; dated Apr. 1, 2016; 11 pages.

Schlumberger; Selective Perforation: A Game Changer in Perforating Technology—Case Study; issued 2012; 14 pages.

SIPO, Search Report dated Mar. 29, 2017, in Chinese: See Search Report for CN App. No. 201480040456.9, 12 pgs. (English Translation 3 pgs.).

State Intellectual Property Office People's Republic of China; First Office Action for Chinese App. No. 201811156092.7; issued Jun. 16, 2020; 6 pages (Eng Translation 8 pages).

State Intellectual Property Office, P.R. China; First Office Action for Chinese App No. 201580011132.7; Issued Jun. 27, 2018; 5 pages (Eng. Translation 9 pages).

State Intellectual Property Office, P.R. China; First Office Action for Chinese App. No. 201610153426.X; issued Mar. 20, 2019; 6 pages (Eng Translation 11 pages).

State Intellectual Property Office, P.R. China; First Office Action for CN App. No. 201480047092.7; Issued on Apr. 24, 2017.

State Intellectual Property Office, P.R. China; First Office Action with full translation for CN App. No. 201480040456.9; issued Mar. 29, 2017; 12 pages (English translation 17 pages).

State Intellectual Property Office, P.R. China; Notification to Grant Patent Right for Chinese App. No. 201580011132.7; issued Apr. 3, 2019; 2 pages (Eng. Translation 2 pages).

State Intellectual Property Office, P.R. China; Notification to Grant Patent Right for CN App. No. 201480040456.9; Jun. 12, 2018; 2 pages (English translation 2 pages).

State Intellectual Property Office, P.R. China; Second Office Action for CN App. No. 201480040456.9; Issued Nov. 29, 2017; 5 pages (English translation 1 page).

State Intellectual Property Office, P.R. China; Second Office Action for CN App. No. 201480047092.7; Issued Jan. 4, 2018; 3 pages.

SWM International Inc.; "Thunder Disposable Gun System"; promotional brochure; Oct. 2018; 5 pgs.

Thilo Scharf; "DynaEnergetics exhibition and product briefing"; pp. 5-6; presented at 2014 Offshore Technology Conference; May 2014.

Thilo Scharf; "DynaStage & BTM Introduction"; pp. 4-5, 9; presented at 2014 Offshore Technology Conference; May 2014.

U.S. Patent Trial and Appeal Board, Institution of Inter Partes Review of U.S. Pat. No. 9,581,422, Case IPR2018-00600, Aug. 21, 2018, 9 pages.

United States District Court for the Southern District of Texas

Houston Division, Case 4:19-cv-01611 for U.S. Pat. No. 9,581,422B2, Defendant's Answers, Counterclaims and Exhibits, dated May 28, 2019, 135 pgs.

United States District Court for the Southern District of Texas

Houston Division, Case 4:19-cv-01611 for U.S. Pat. No. 9,581,422B2, Plaintiffs' Motion to Dismiss and Exhibits, dated Jun. 17, 2019, 63 pgs.

United States District Court for the Southern District of Texas Houston Division, Case 4:19-cv-01611 for U.S. Pat. No. 9,581,422B2, Plaintiff's Complaint and Exhibits, dated May 2, 2019, 26 pgs.

United States Patent and Trademark Office, Notice of Allowance for U.S. Appl. No. 29/729,981, Sep. 18, 2020, 9 pages.

United States Patent and Trademark Office, Case IPR2018-00600 for U.S. Pat. No. 9,581,422 B2, Reply In Support of Patent Owner's Motion to Amend, dated Mar. 21, 2019, 15 pgs.

United States Patent and Trademark Office, Case IPR2018-00600 for U.S. Pat. No. 9,581,422 B2, Decision of Precedential Opinion Panel, Granting Patent Owner's Request for Hearing and Granting Patent Owner's Motion to Amend, dated Jul. 6, 2020, 27 pgs.

United States Patent and Trademark Office, Case IPR2018-00600 for U.S. Pat. No. 9,581,422 B2, DynaEnergetics GmbH & Co. KG's Patent Owner Preliminary Response, dated May 22, 2018, 47 pgs.

United States Patent and Trademark Office, Case IPR2018-00600 for U.S. Pat. No. 9,581,422 B2, Order Granting Precedential Opinion Panel, Paper No. 46, dated Nov. 7, 2019, 4 pgs.

United States Patent and Trademark Office, Case IPR2018-00600 for U.S. Pat. No. 9,581,422 B2, Patent Owner's Motion to Amend, dated Dec. 6, 2018, 53 pgs.

United States Patent and Trademark Office, Case IPR2018-00600 for U.S. Pat. No. 9,581,422 B2, Patent Owner's Opening Submission to Precedential Opinion Panel, dated Dec. 20, 2019, 21 pgs.

United States Patent and Trademark Office, Case IPR2018-00600 for U.S. Pat. No. 9,581,422 B2, Patent Owner's Request for Hearing, dated Sep. 18, 2019, 19 pgs.

United States Patent and Trademark Office, Case IPR2018-00600 for U.S. Pat. No. 9,581,422 B2, Patent Owner's Responsive Submission to Precedential Opinion Panel, dated Jan. 6, 2020, 16 pgs.

United States Patent and Trademark Office, Case IPR2018-00600 for U.S. Pat. No. 9,581,422 B2, Patent Owner's Sur-reply, dated Mar. 21, 2019, 28 pgs.

United States Patent and Trademark Office, Case IPR2018-00600 for U.S. Pat. No. 9,581,422 B2, Petitioner's Additional Briefing to the Precedential Opinion Panel, dated Dec. 20, 2019, 23 pgs.

United States Patent and Trademark Office, Case IPR2018-00600 for U.S. Pat. No. 9,581,422 B2, Petitioner's Opposition to Patent Owner's Motion to Amend, dated Mar. 7, 2019, 30 pgs.

United States Patent and Trademark Office, Case IPR2018-00600 for U.S. Pat. No. 9,581,422 B2, Petitioner's Reply Briefing to the Precedential Opinion Panel, dated Jan. 6, 2020, 17 pgs.

United States Patent and Trademark Office, Case IPR2018-00600 for U.S. Pat. No. 9,581,422 B2, Petitioner's Reply in Inter Partes Review of Patent No. 9,581,422, dated Mar. 7, 2019, 44 pgs.

United States Patent and Trademark Office, Final Written Decision of Case IPR2018-00600 for U.S. Pat. No. 9,581,422 B2, Paper No. 42, dated Aug. 20, 2019, 31 pgs.

United States Patent and Trademark Office, Non-final Office Action of U.S. Appl. No. 16/451,440, dated Oct. 24, 2019, 22 pgs.

United States Patent and Trademark Office, Non-final Office Action of U.S. Appl. No. 16/455,816, dated Jul. 2, 2020, 15 pgs.

United States Patent and Trademark Office, Non-final Office Action of U.S. Appl. No. 16/455,816, dated Nov. 5, 2019, 17 pgs.

United States Patent and Trademark Office, Office Action of U.S. Appl. No. 15/617,344, dated Jan. 23, 2019, 5 pgs.

United States Patent and Trademark Office, Office Action of U.S. Appl. No. 15/788,367, dated Oct. 22, 2018, 6 pgs.

United States Patent and Trademark Office, Office Action of U.S. Appl. No. 15/920,800, dated Dec. 27, 2019, 6 pgs.

United States Patent and Trademark Office, Office Action of U.S. Appl. No. 15/920,812, dated May 27, 2020, 5 pgs.

United States Patent and Trademark Office, Office Action of U.S. Appl. No. 16/272,326, dated May 24, 2019, 17 pgs.

United States Patent and Trademark Office, Office Action of U.S. Appl. No. 16/423,789, dated Feb. 18, 2020, 14 pgs.

United States Patent and Trademark Office, Office Action of U.S. Appl. No. 16/455,816, dated Apr. 20, 2020, 21 pgs.

United States Patent and Trademark Office, Office Action of U.S. Appl. No. 16/455,816, dated Jan. 13, 2020, 14 pgs.

United States Patent and Trademark Office, Office Action of U.S. Appl. No. 16/511,495, dated Aug. 27, 2020, 20 pgs.

(56)

References Cited

OTHER PUBLICATIONS

- United States Patent and Trademark Office, Office Action of U.S. Appl. No. 16/585,790, dated Nov. 12, 2019, 9 pgs.
- United States Patent and Trademark Office, U.S. Appl. No. 61/733,129, filed Dec. 4, 2012; 10 pages.
- United States Patent and Trademark Office, U.S. Appl. No. 61/819,196, filed May 3, 2013 ; 10 pages.
- United States Patent and Trademark Office; Final Office Action for U.S. Appl. No. 16/299,952; Issued May 15, 2020; 10 pages.
- United States Patent and Trademark Office; Final Office Action of U.S. Appl. No. 16/540,484; dated Mar. 30, 2020; 12 pgs.
- United States Patent and Trademark Office; Non-Final Office Action for U.S. Appl. No. 16/379,341; Sep. 21, 2020; 15 pages.
- United States Patent and Trademark Office; Non-Final Office Action for U.S. Appl. No. 16/542,890; issued Nov. 4, 2019; 16 pages.
- United States Patent and Trademark Office; Non-Final Office Action for U.S. Appl. No. 16/299,952; Issued Oct. 18, 2019; 12 pages.
- United States Patent and Trademark Office; Notice of Allowability for U.S. Appl. No. 14/908,788; dated Dec. 27, 2017; 5 pages.
- United States Patent and Trademark Office; Notice of Allowance for U.S. Appl. No. 15/920,812, mailed Aug. 18, 2020; 5 pages.
- United States Patent and Trademark Office; Notice of Allowance for U.S. Appl. No. 16/423,789; dated Jul. 23, 2020 7 pages.
- United States Patent and Trademark Office; Notice of Allowance for U.S. Appl. No. 16/455,816; mailed on Sep. 22, 2020; 12 pages.
- United States Patent and Trademark Office; Notice of Non-Compliant Amendment for U.S. Appl. No. 16/299,952; Issued Apr. 23, 2020; 2 pages.
- United States Patent and Trademark Office; Office Action for U.S. Appl. No. 17/004,966; dated Dec. 8, 2020; 30 pages.
- United States Patent and Trademark Office; Office Action of U.S. Appl. No. 16/540,484, dated Aug. 20, 2020, 10 pgs.
- United States Patent and Trial Appeal Board; Final Written Decision on IPR2018-00600; issued Aug. 20, 2019; 31 pages.
- USPTO, Notice of Allowance for U.S. Appl. No. 16/423,230, mailed Nov. 27, 2019, 7 pgs.
- USPTO; Notice of Allowance for U.S. Appl. No. 14/904,788; mailed Jul. 6, 2016; 8 pages.
- USPTO; Supplemental Notice of Allowability for U.S. Appl. No. 14/904,788; mailed Jul. 21, 2016; 2 pages.
- Vigor USA; "Sniper Addressable System"; promotional brochure; Sep. 2019.
- Wade et al., Field Tests Indicate New Perforating Devices Improve Efficiency in Casing Completion Operations, SPE 381, pp. 1069-1073, Oct. 1962, 5 pgs.
- WIPO, International Search Report for International Application No. PCT/CA2014/050673, mailed Oct. 9, 2014, 3 pgs.
- WIPO, Written Opinion of International Searching Authority for PCT Application No. PCT/CA2014/050673, mailed Oct. 9, 2014, 4 pgs.
- EQUAfrac Brochure; Exhibit No. 1016 of PGR No. 2021-00089; 6 pages.
- EQUAfrac Shaped Charges; Exhibit No. 1018 of PGR No. 2021-00089; dated 2018; 2 pages.
- Global Presence Hunting PLC—2014 Full Year Results; Exhibit No. 1019 of PGR No. 2021-00089; dated 2014; 30 pages.
- H-1 Perforating Gun System; Exhibit No. 1022 of PGR No. 2021-00089; dated May 1, 2020; 6 pages.
- Marketing White Paper: EQUAfrac Shaped Charge; Exhibit 1017 of PGR No. 2021-00089; dated Jan. 2017; 5 pages.
- Parrott, Robert A.; Declaration in Support of PGR20201-00089; dated Jun. 1, 2021; 353 pages.
- Perf.com VaporGun; Exhibit No. 1021 of PGR No. 2021-00089; dated Aug. 6, 2020; <http://www.perf.com/vaporgun>; 4 pages.
- Perforating Guns and Setting Tools; Exhibit 1015 of PGR No. 2021-00089; dated Dec. 2019; 33 pages.
- Perforating Services Catalog 2008 part 1 of 2; Exhibit 1020 of PGR No. 2021-00089 dated 2008; 282 pages.
- Perforating Services Catalog 2008 part 2 of 2; Exhibit 1020 of PGR No. 2021-00089; dated 2008; 239 pages.
- Schlumberger Technology Corporation; Petition for Post Grant Review Case No. PGR2021-00089; dated Jun. 1, 2021; 155 pages.
- United States Patent and Trademark Office; Advisory Action Before the Filing of an Appeal Brief for U.S. Appl. No. 17/004,966; mailed on May 21, 2021; 3 pages.
- United States Patent and Trademark Office; U.S. Appl. No. 62/002,559; dated May 23, 2014; 19 pages.
- United States Patent and Trademark Office; U.S. Appl. No. 62/002,565; dated Jun. 25, 2014; 25 pages.
- United States Patent and Trademark Office; U.S. Appl. No. 62/014,900; dated Jul. 7, 2014; 25 pages.
- United States Patent and Trademark Office; U.S. Appl. No. 62/015,014; dated Jul. 7, 2014; 21 pages.
- United States Patent and Trademark Office; U.S. Appl. No. 62/015,030; dated Jul. 14, 2014; 29 pages.
- United States Patent and Trademark Office; U.S. Appl. No. 62/112,935; dated Feb. 6, 2015; 33 pages.
- United States Patent and Trademark Office; U.S. Appl. No. 62/131,324; dated Mar. 24, 2015; 65 pages.
- United States Patent and Trademark Office; U.S. Appl. No. 62/621,999; dated Jan. 25, 2018; 42 pages.
- United States Patent and Trademark Office; U.S. Appl. No. 62/627,591; dated Feb. 7, 2018; 40 pages.
- DynaEnergetics Europe GmbH; Patent Owner's Preliminary Response for PGR No. 2021-00089; dated Sep. 16, 2021; 106 pages.
- Rodgers, John; Declaration for PGR No. 2021-00089; dated Sep. 16, 2021; 93 pages.
- Scharf, Thilo; Declaration for PGR No. 2021-00089; dated Sep. 16, 2021; 8 pages.
- Schlumberger Technology Corporation; Defendant's Preliminary Invalidation Contentions; dated Aug. 19, 2021; 213 pages.
- Schlumberger Technology Corporation; Exhibit A-01 to Defendant's Preliminary Invalidation Contentions Invalidation of U.S. Pat. No. 10,844,696 over WO20190148009; dated Aug. 19, 2021; 267 pages.
- Schlumberger Technology Corporation; Exhibit A-02 to Defendant's Preliminary Invalidation Contentions Invalidation of U.S. Pat. No. 10,844,696 over U.S. Pat. No. 4,598,775; dated Aug. 19, 2021; 178 pages.
- Schlumberger Technology Corporation; Exhibit A-03 to Defendant's Preliminary Invalidation Contentions Invalidation of U.S. Pat. No. 10,844,696 over U.S. Pat. No. 4,753,301; dated Aug. 19, 2021; 178 pages.
- Schlumberger Technology Corporation; Exhibit A-04 to Defendant's Preliminary Invalidation Contentions Invalidation of U.S. Pat. No. 10,844,696 over U.S. Pat. No. 10,746,003; dated Aug. 19, 2021; 186 pages.
- Schlumberger Technology Corporation; Exhibit A-05 to Defendant's Preliminary Invalidation Contentions Invalidation of U.S. Pat. No. 10,844,696 over WO2017/024266; dated Aug. 19, 2021; 247 pages.
- Schlumberger Technology Corporation; Exhibit A-06 to Defendant's Preliminary Invalidation Contentions Invalidation of U.S. Pat. No. 10,844,696 over U.S. Pat. No. 4,479,556; dated Aug. 19, 2021; 250 pages.
- Schlumberger Technology Corporation; Exhibit A-07 to Defendant's Preliminary Invalidation Contentions Invalidation of U.S. Pat. No. 10,844,696 over US2017/0145798; dated Aug. 19, 2021; 279 pages.
- United States Patent and Trademark Office; U.S. Appl. No. 62/736,298; dated Sep. 25, 2018; 120 pages.
- International Searching Authority; International Preliminary Report on Patentability for PCT Application No. PCT/EP2019/069165; mailed on Jan. 28, 2021; 9 pages.
- International Searching Authority; International Preliminary Report on Patentability for PCT Application No. PCT/IB2019/000569; dated Jan. 28, 2021; 8 pages.
- United States Patent and Trademark Office; Final Office Action for U.S. Appl. No. 17/004,966; dated Mar. 12, 2021; 18 pages.
- United States Patent and Trademark Office; Notice of Allowance for U.S. Appl. No. 29/755,354; dated Feb. 11, 2021; 6 pages.
- Hunting Titan, Wireline Hardware, Logging Instruments EBFire, TCB Systems, Gun Systems, Oct. 15, 2015, V.9.1, 72 pgs., <http://www.hunting-intl.com/media/1305595/hunting-titan-complete-v9-1.pdf>.

(56)

References Cited

OTHER PUBLICATIONS

International Searching Authority; International Search Report and Written Opinion for International Application No. PCT/US19/15255; dated Apr. 23, 2019; 12 pages.

Schlumberger Technology Corporation, Defendant Schlumberger Technology Corporation's Opening Claim Construction Brief for Civil Action No. 6:21-cv-00225-ADA; dated Oct. 6, 2021; 27pages.

Schlumberger Technology Corporation; Defendant Schlumberger Technology Corporation's Reply To Plaintiffs' Responsive Claim Construction Brief; dated Nov. 10, 2021; 17 pages.

Schlumberger Technology Corporation; Petitioner's Reply to Patent Owner's Preliminary Response; dated Oct. 13, 2021; 14 pages.

United States Patent and Trademark Office; Decision Denying Institution of Post-Grant Review for PGR2021-00089; dated Dec. 14, 2021; 51 pages.

United States Patent and Trademark Office; Notice of Allowance for U.S. Appl. No. 17/004,966; dated Nov. 8, 2021; 12 pages.

Wooley, Gary R; Declaration of Gary R. Wooley, PH.D. Regarding Claim Construction for Civil Action No. 6:21-cv-00225-ADA; dated Oct. 6, 2021; 67 pages.

Wooley, Gary; Rebuttal Declaration of Gary R. Wooley, Ph.D. Regarding Claim Construction; dated Nov. 10, 2021; 34 pages.

* cited by examiner

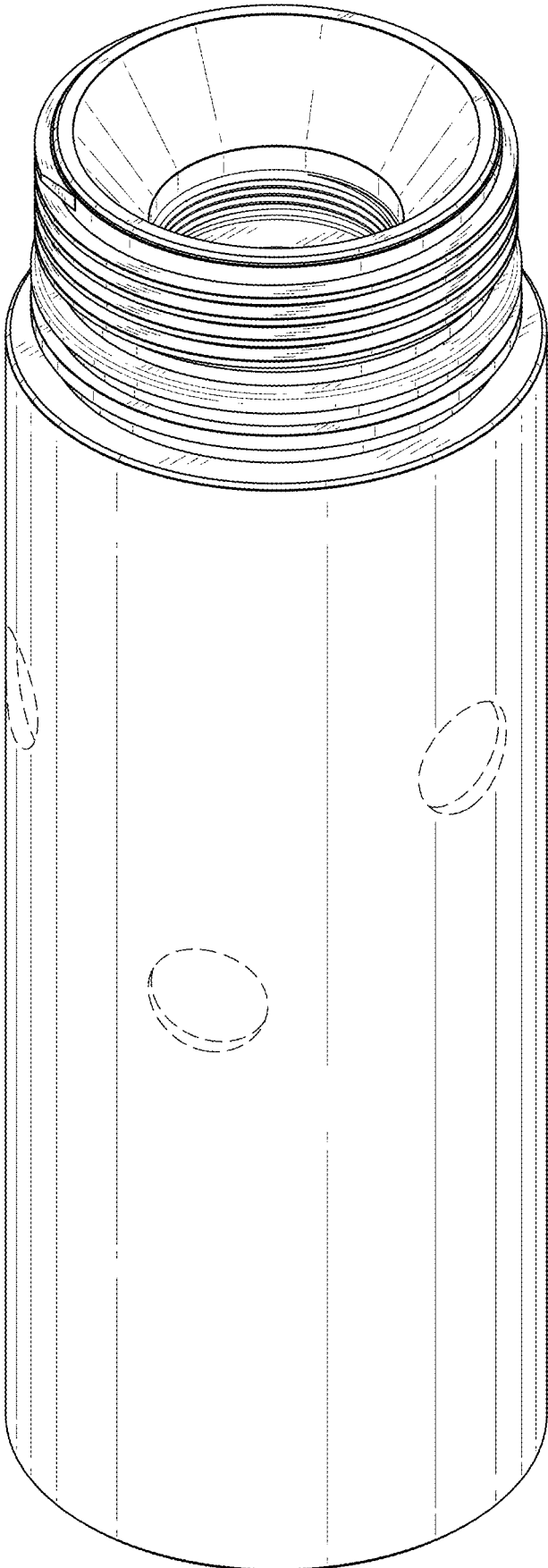

FIG. 1

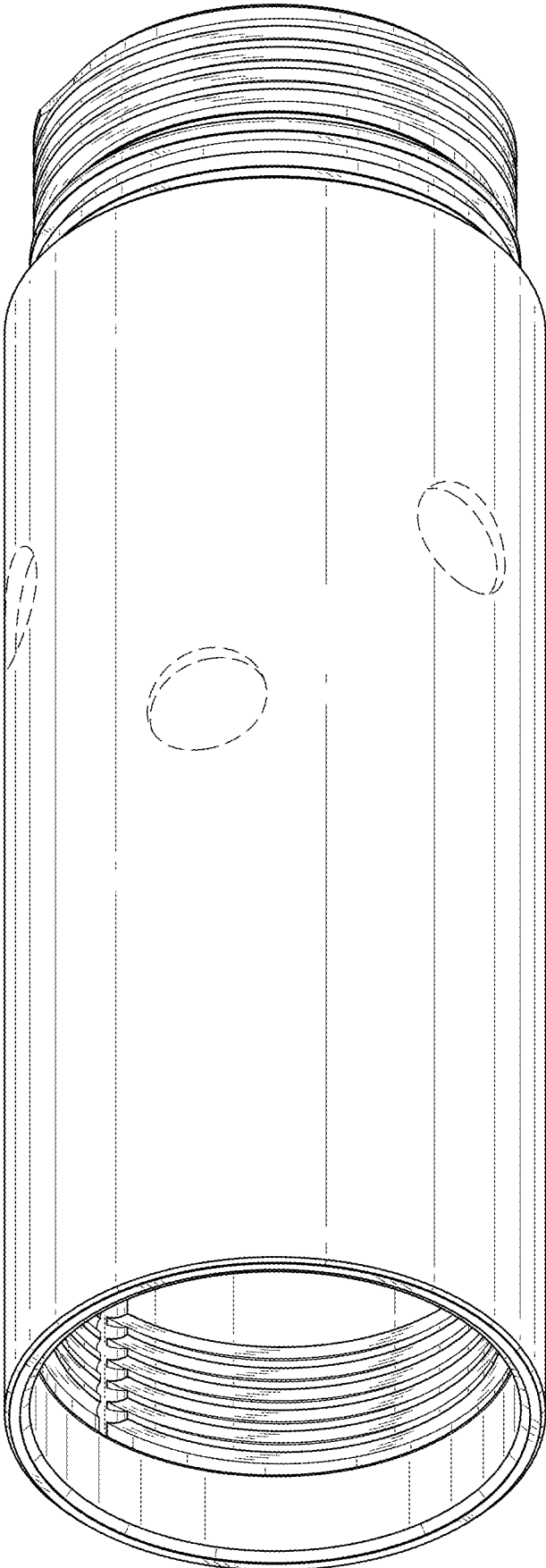

FIG. 2

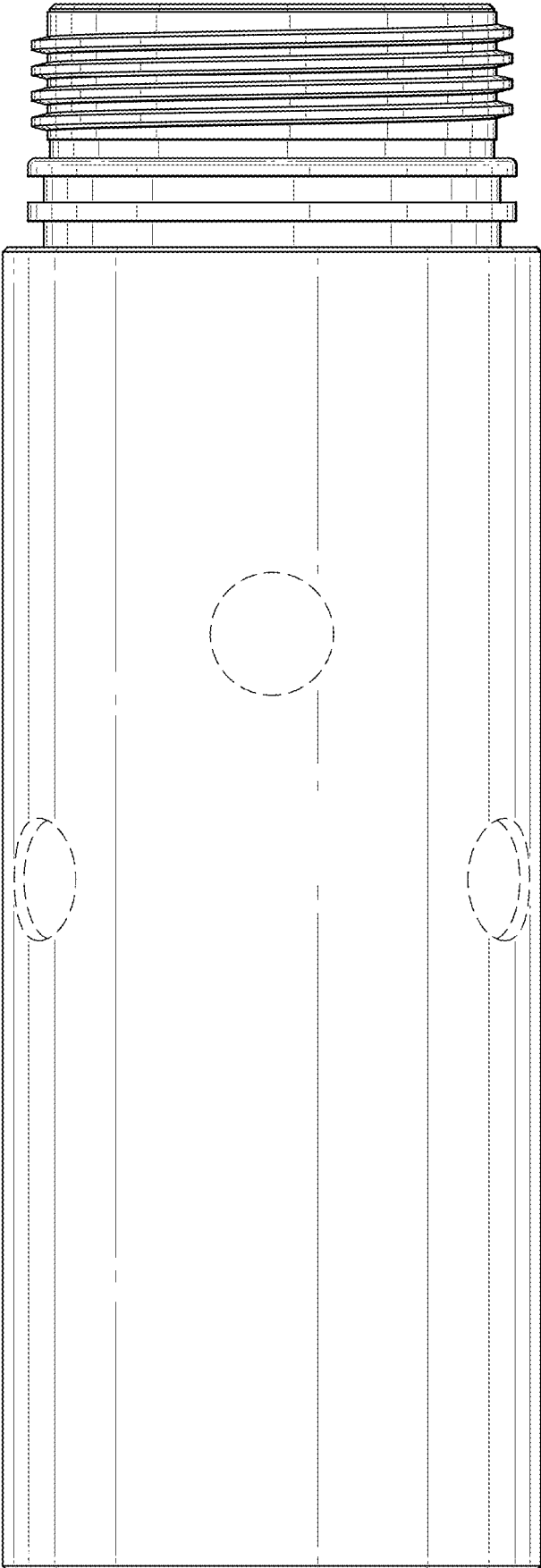

FIG. 3

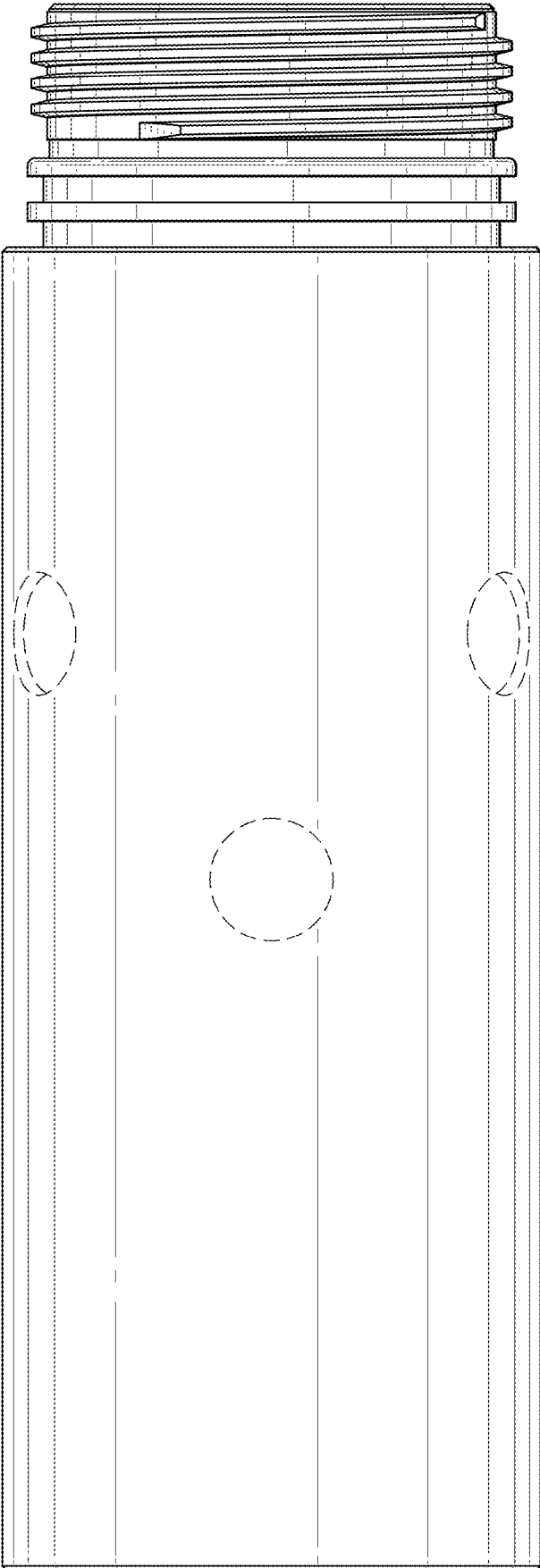

FIG. 4

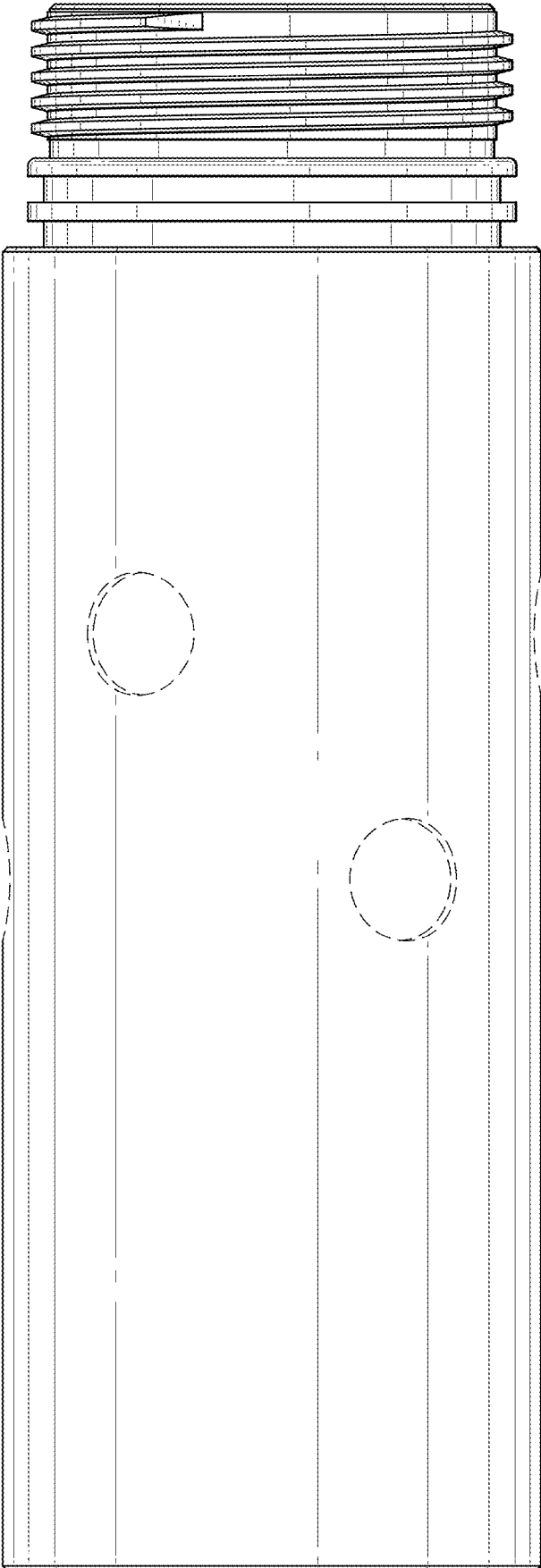

FIG. 5

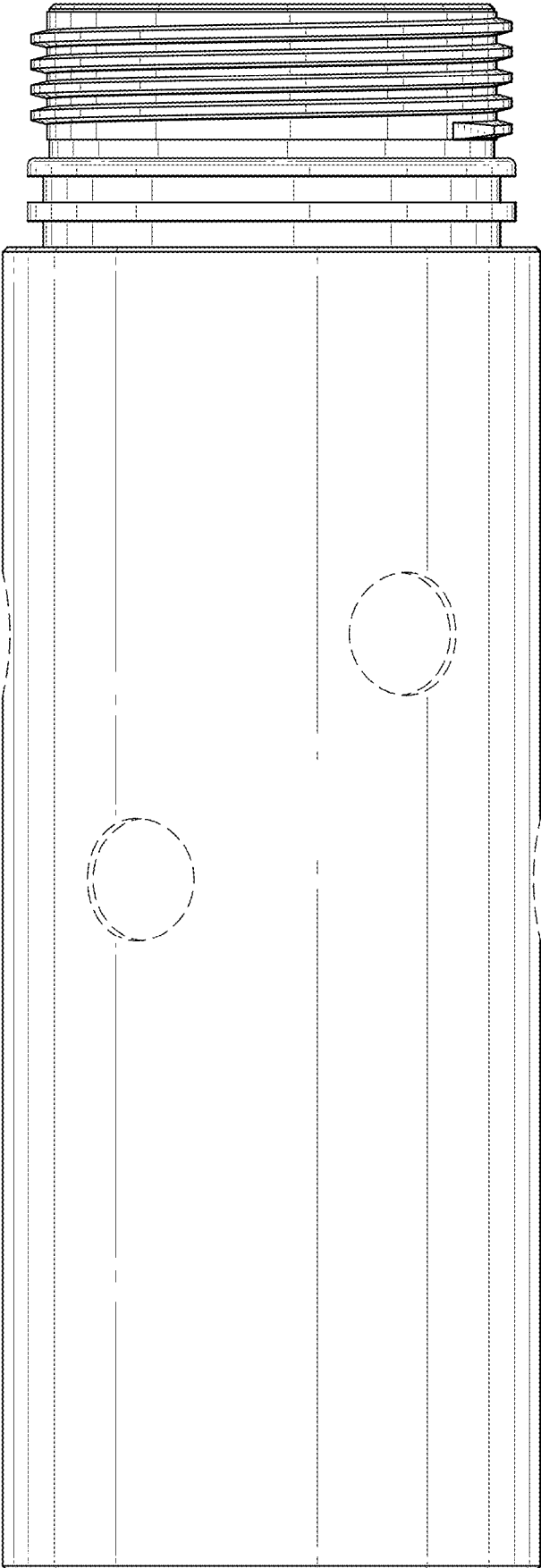

FIG. 6

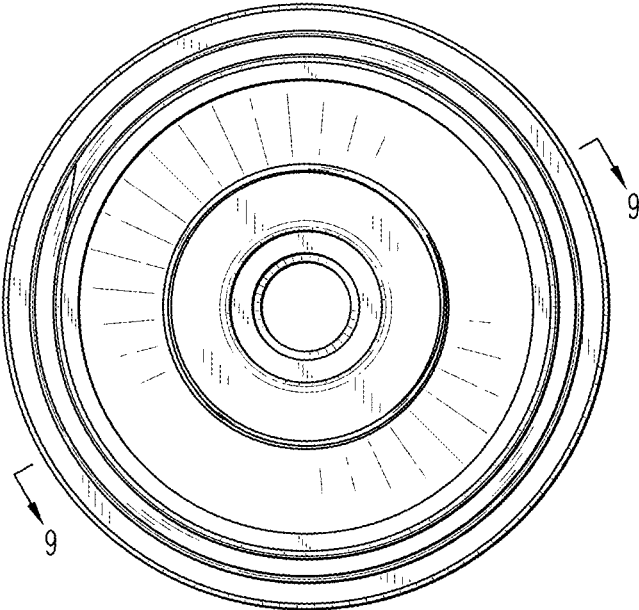

FIG. 7

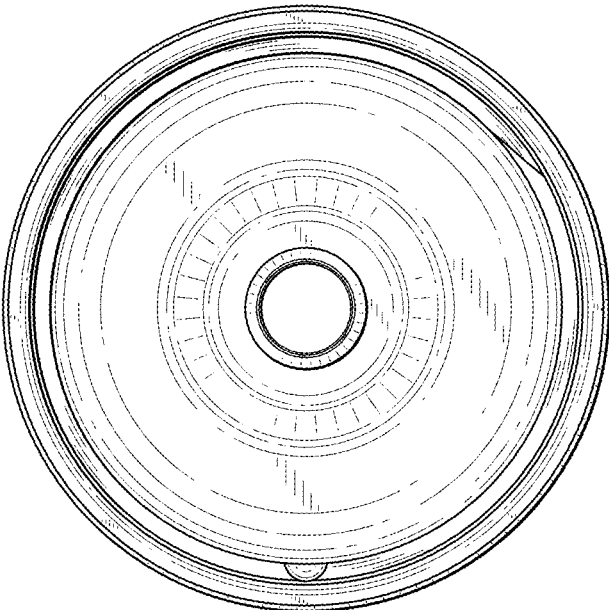

FIG. 8

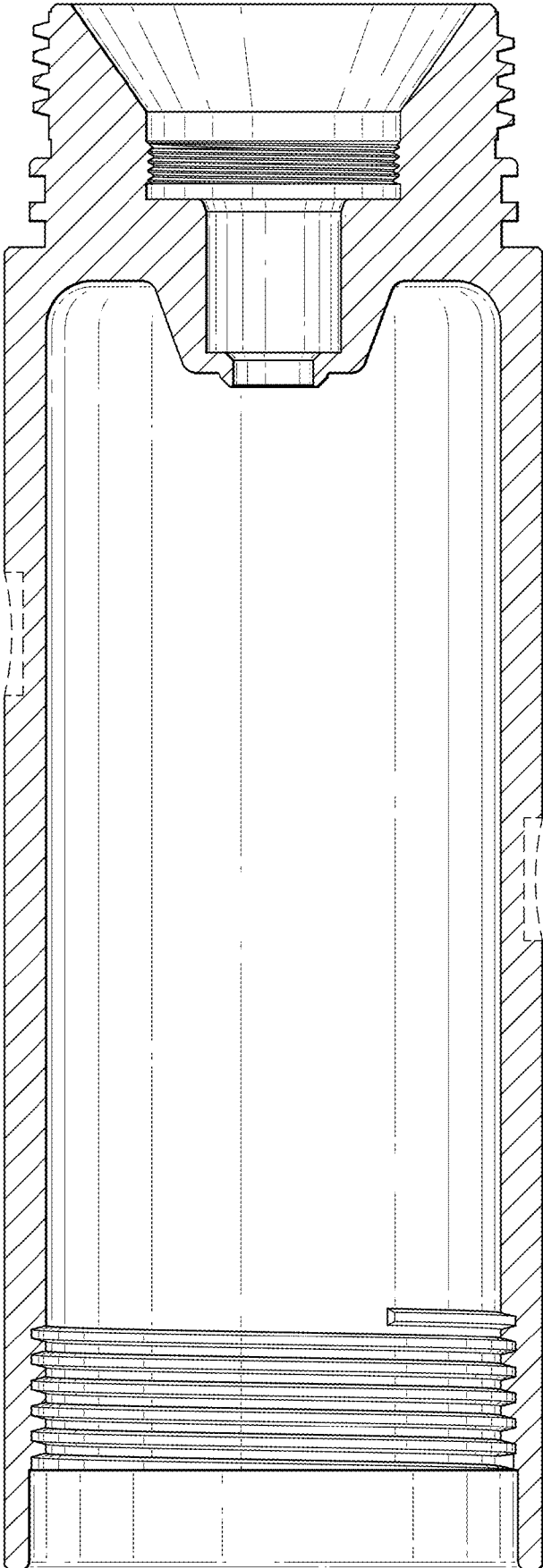

FIG. 9