

F. HENGEL & J. ADDIS  
 AUTOMOBILE TOOL BOX.  
 APPLICATION FILED MAR. 16, 1910.

969,620.

Patented Sept. 6, 1910.

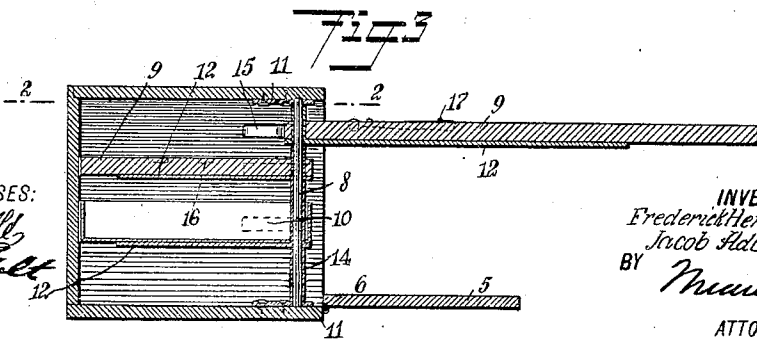
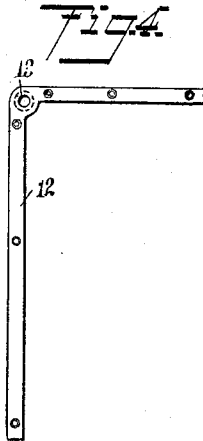
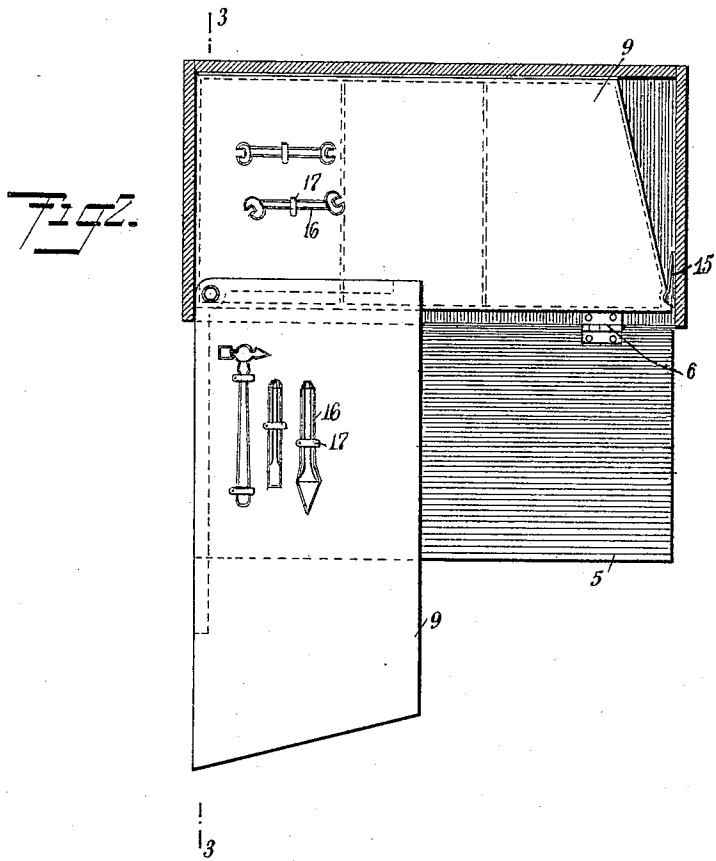
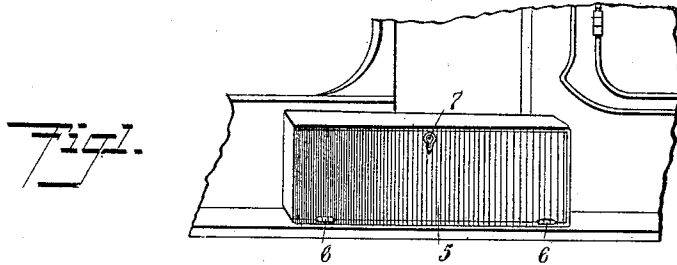

WITNESSES:  
*Ben. Jeff*  
*sub. Holt*

INVENTORS  
 Frederick Hengel  
 Jacob Haldis  
 BY *Mausler*  
 ATTORNEYS

# UNITED STATES PATENT OFFICE,

FREDERICK HENGEL AND JACOB ADDIS, OF NEW YORK, N. Y.

AUTOMOBILE TOOL-BOX.

969,620.

Specification of Letters Patent.

Patented Sept. 6, 1910.

Application filed March 16, 1910. Serial No. 549,651.

To all whom it may concern:

Be it known that we, FREDERICK HENGEL, a citizen of the United States, and JACOB ADDIS, a subject of the King of Great Britain, and residents, respectively, of the city of New York, borough of the Bronx, and of the city of New York, borough of Manhattan, in the county and State of New York, have invented a new and Improved Automobile Tool-Box, of which the following is a full, clear, and exact description.

The invention is an improvement in tool boxes for motor vehicles, and embodies a box in which the tools are accessibly contained, as by arranging them on shelves and in one or more drawers hinged on a fixed vertical rod or axis adjacent to an outer corner of the box, the outer side of the box being hinged at the bottom, affording a door, which when opened, permits of the shelves and drawer swinging on the axis in a horizontal plane, to the outside of the box.

The invention has in view a tool box of this character of substantial construction, in which the shelves and drawers will be positively held against rattling and will be automatically released and engaged when drawn from and swung into the box.

Reference is to be had to the accompanying drawings forming a part of this specification, in which similar characters of reference indicate corresponding parts in all the views.

Figure 1 is a fragmentary perspective view of a motor vehicle, showing a tool box constructed in accordance with our invention, placed on the running board and serving as a step; Fig. 2 is a horizontal section of the box substantially on the line 2—2 of Fig. 3; Fig. 3 is a vertical section substantially on the line 3—3 of Fig. 2; and Fig. 4 is a plan of the corner brace used in connection with each shelf or drawer.

The invention comprises an outer casing or box of substantial length and height, with the outer side 5 hinged at the bottom edge, as indicated at 6, and serving as a door, this manner of connecting the door adapting it to swing downwardly and outwardly to a removed position, as shown in Figs. 2 and 3, as when access to the box is to be had, the door having any suitable lock 7 at the top. Adjacent to one of the outer corners of the box is a relatively fixed vertical rod or axis 8, on which shelves 9 and one or more drawers 10 are hinged or pivoted

at the corners to swing horizontally to the outside of the box when the door 5 is opened, the rod or axis 8 having its ends fitted within sockets 11 respectively secured to the top and bottom of the box at the inside. The shelves 9 and drawer 10 are each preferably reinforced by an L-shaped bar 12, shown in detail in Fig. 4, one of these bars being secured to the under side of each shelf and drawer to extend along the end and front side, each reinforcing bar having an opening 13 at the angle, through which the rod or axis 8 passes. As best shown in Fig. 3, the shelves 9 are arranged in the upper portion of the box and the drawer underneath the shelves, each being spaced apart a distance so as to not interfere with the movement of another when the tools which they are to carry are in place. For thus supporting the shelves and drawer, the rod or axis 8 is provided with a number of thimbles 14, certain of the thimbles being in the nature of bosses, integral with the bars 12 and sockets 11 and of such length as to stand between and bear against the bottoms and tops of the shelves, drawer and box, the wear of the thimbles, incident to the swinging of the shelves and drawer, being taken by the reinforcing bar 12. The free ends of the shelves and drawer are beveled or rounded off, as shown in Fig. 2, so that they will clear the box when swung on the vertical rod.

If desired, a suitable catch 15 may be provided for each shelf and drawer, and arranged to automatically release and engage the same and lock it against accidental displacement when the shelf or drawer is fully swung to the inside of the box. These catches, however, are not essential, for, as shown by Figs. 2 and 3, the pivoted ends of the shelves and drawer, as also their inner edges, bear flat against the adjacent walls of the box when the shelves and drawer are fully closed; and the hinged front of the box bears, when closed, against the front edges of the shelves and drawer so that there is no opportunity for the rattling of these parts when the vehicle is in motion. The spring catches will nevertheless be of service at times, as when the automobile is laterally inclined on the road, with the box at the low side, for under such circumstances, without the catches, all of the shelves and drawers will swing out of the box when the front of the box is dropped.

Each shelf is shown to be provided with a number of tool depressions 16, which are located at suitable points in its upper face, each depression being of a form of the tool 5 which it is to contain, and having a spring clip 17, bridging the depression at an intermediate point, the spring clips bearing on the tops of the tools and serving to prevent their displacement or rattling. The 10 drawer 10 is shown to be elevated a substantial distance above the bottom of the chest, which leaves sufficient space for overalls, waste, and the like.

Having thus described our invention, we 15 claim as new and desire to secure by Letters Patent:

A box suitable for containing tools for 20 motor vehicles, having the outer side thereof hinged at the bottom edge and serving as a door, sockets fixed to the top and bottom of the box at the inside thereof adjacent to

an outer corner, a vertical rod having its ends fitted within the sockets, a number of tool shelves and tool drawers each pivoted 25 on the rod to swing without and within the box when the door is open, each shelf and drawer having an L-shaped reinforcing bar secured to the under side thereof adjacent to the front and pivoted end thereof, with 30 the said vertical rod passing through the angle of the reinforcing bar, and thimbles arranged on the rod, supporting the shelves and drawers in spaced relation and bearing against the reinforcing bars.

In testimony whereof we have signed our 35 names to this specification in the presence of two subscribing witnesses.

FREDERICK HENGEL.  
JACOB ADDIS.

Witnesses:

THOMAS F. O'ROURKE,  
JAS. E. CALLAN.