

[54] **MULTICOMPARTMENT CONNECTOR**
 [75] Inventor: **Lai Che Kuo**, Elizabeth, N.J.
 [73] Assignee: **Thomas & Betts Corporation**,
 Elizabeth, N.J.
 [22] Filed: **March 29, 1971**
 [21] Appl. No.: **129,003**

3,134,844 5/1964 Myers.....174/94 R
 3,331,106 7/1967 Ruskin.....24/123 W
 3,355,698 11/1967 Keller.....339/97 C
 3,514,528 5/1970 Ray.....339/97 C
 3,594,704 7/1971 Fischer.....339/97 C

Primary Examiner—Joseph H. McGlynn
Attorney—David Teschner and Jesse Woldman

[52] U.S. Cl.339/98, 24/123 W, 174/84 C,
 174/94 R, 339/276 R
 [51] Int. Cl.H01r 11/20
 [58] Field of Search.....339/95, 97-99,
 339/276; 24/20 R, 23 R, 30.5 W, 115 A, 123
 W, 129 W; 174/84 C, 94 R

[57] **ABSTRACT**

A uniquely formed, deformable, multicompartment connector having two or more adjacently disposed, independently deformable article receiving portions selectively arranged for intimate engagement about one or more articles disposed therewithin, to provide a secure coupling therebetween. The connector may be suitably formed from electrically conducting material, with locking means and internally disposed teeth, to provide a highly effective electrical connector for use in conjunction with variously configured insulated or noninsulated electrical conductors.

[56] **References Cited**

UNITED STATES PATENTS

3,387,080 6/1968 Dibble et al.339/276 R
 2,884,478 4/1959 Becker et al.174/94 R
 3,045,303 7/1962 Wade.....24/123 W

10 Claims, 15 Drawing Figures

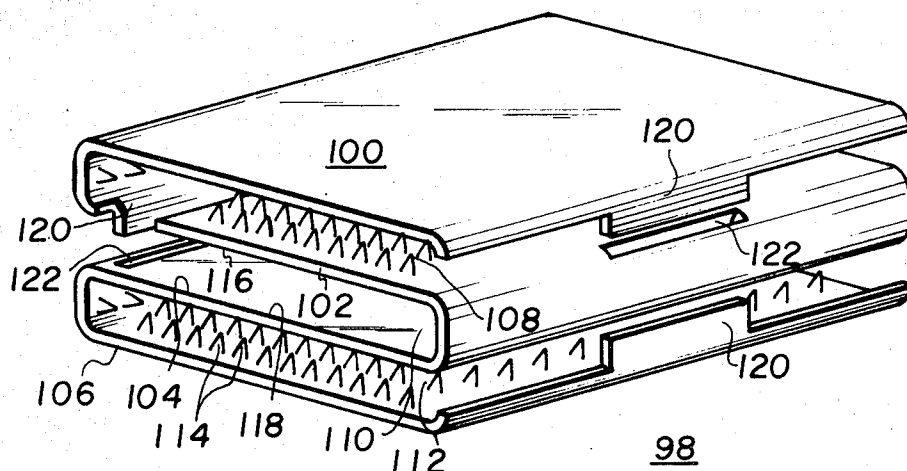

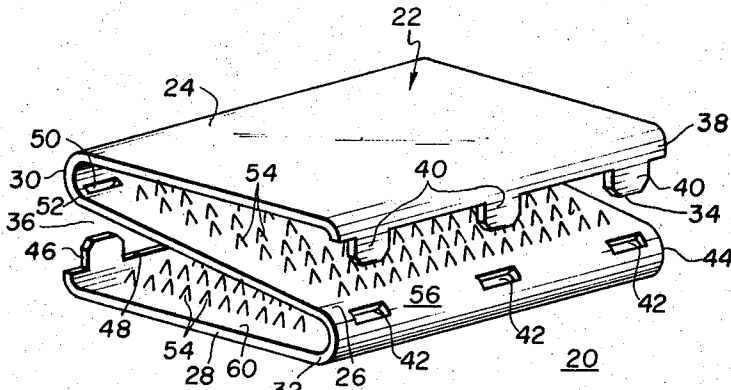

FIG. 1

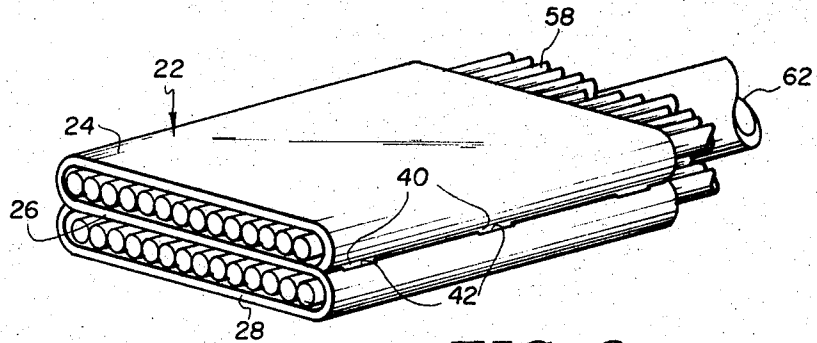

FIG. 2

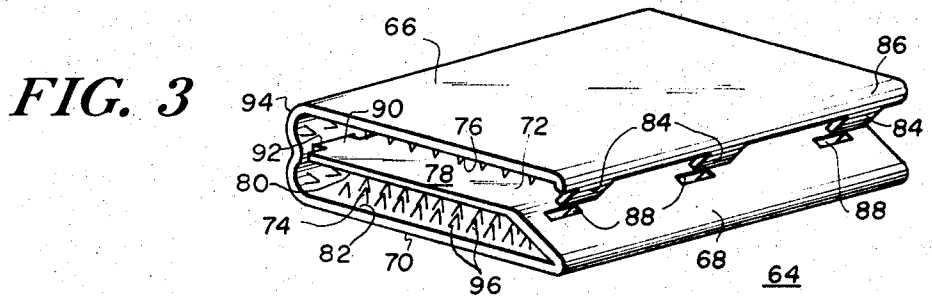

FIG. 3

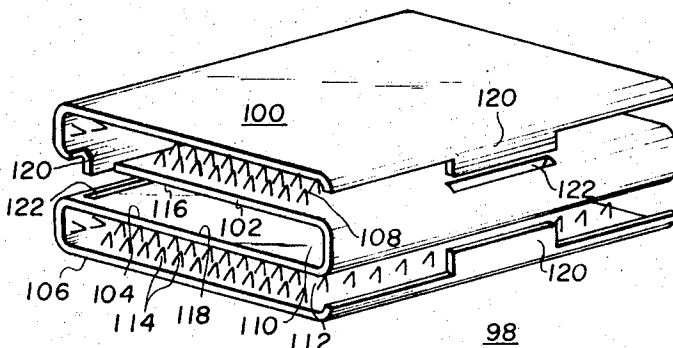

FIG. 4

INVENTOR.
LAI CHE KUO

BY

[Signature]
AGENT

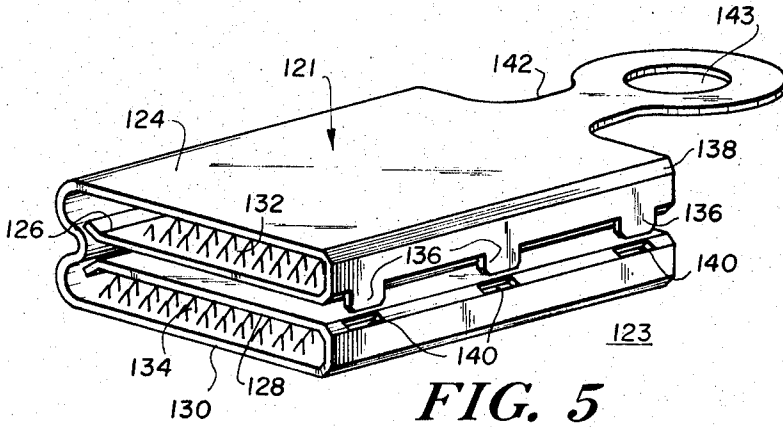

FIG. 5

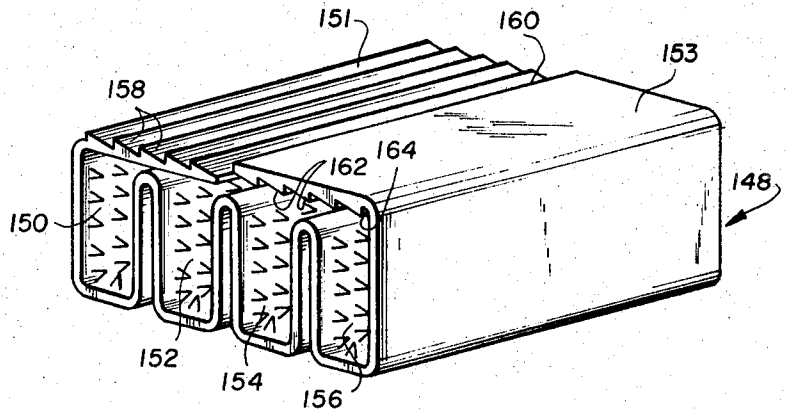

FIG. 6

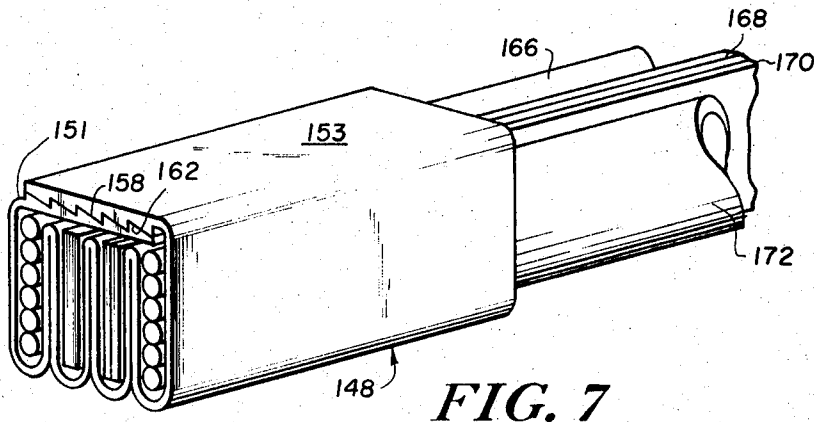

FIG. 7

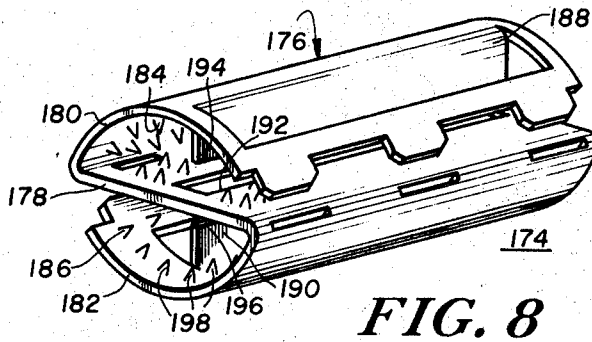

FIG. 8

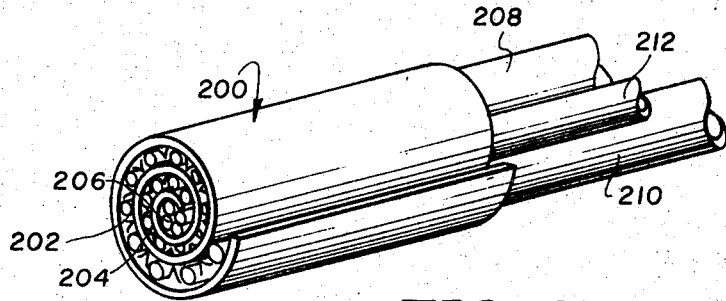

FIG. 9

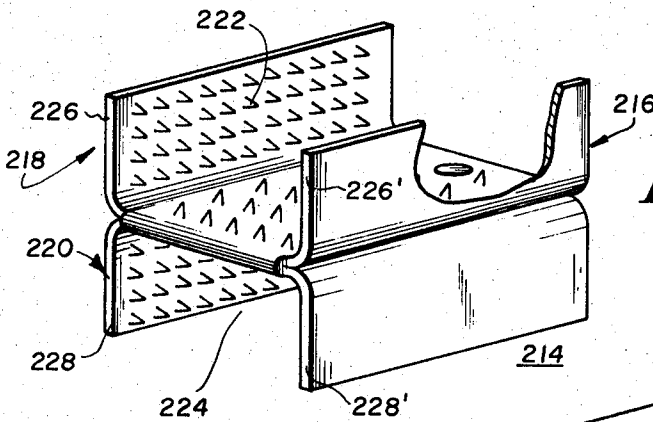

FIG. 10

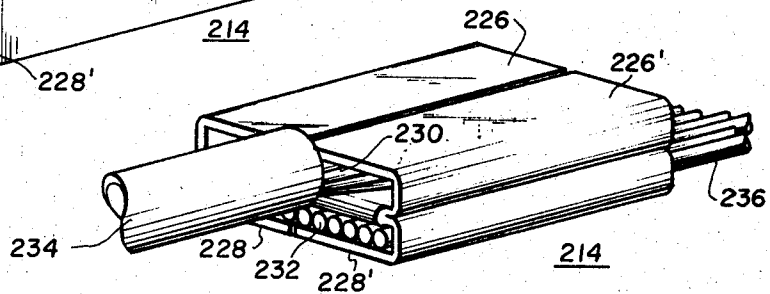

FIG. 11

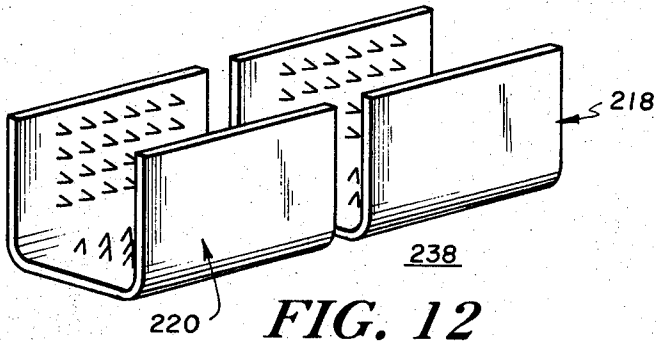

FIG. 12

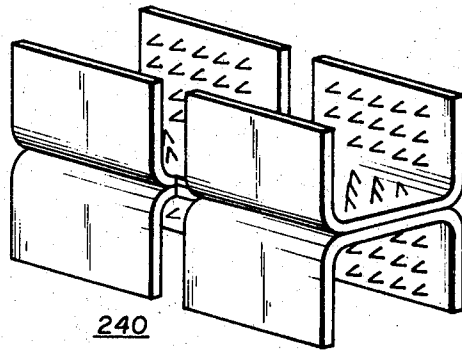

FIG. 13

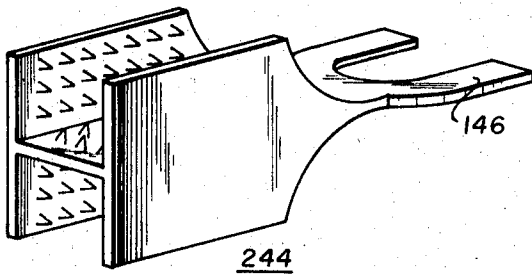

FIG. 14

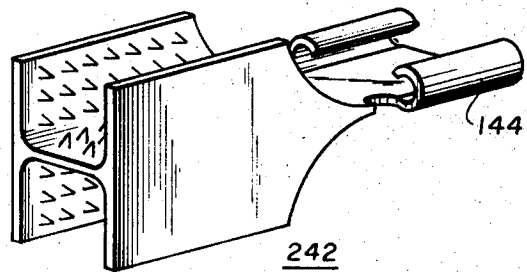

FIG. 15

MULTICOMPARTMENT CONNECTOR

BACKGROUND OF THE INVENTION

1. Field of the Invention

The invention is directed to the field of coupling means and principally to a deformable connector intimately engageable about a plurality of discrete articles.

2. Description of the Prior Art

Deformable connectors for coupling a plurality of discrete articles in secure adjacent relationship, according to the prior art, generally comprised a single passage article receiving portion within which the articles to be coupled were placed in adjacent relationship, the receiving portion then being deformed about said articles by the utilization of one or more commonly employed methods in an attempt to effect a secure coupling therebetween. In many cases, however, a faulty or insecure coupling resulted where the articles were either differently configured or differently sized, due to the necessarily restrictive deformable configuration obtainable within the limits of such single passage prior art devices. Further, where such devices were employed for the interconnection of electrical conductors or the like, they were generally found to be unsatisfactory, since, as was generally the case, such connectors were required to receive various combinations of differently sized and configured both stranded and solid wires, and were generally insufficiently deformable to adequately intimately encompass the variously configured and sized wires disposed therewithin in order to insure their secure retention within the device, and to insure effective electrical coupling between adjacently disposed wires. Attempts to avoid the above problems and limitations of such devices were generally expensive, time consuming, inefficient, and undesirably restrictive, one commonly employed method requiring the use of separate, discrete terminating members, later joined to provide an electrically coupled assembly thereby, the coupling of such individual members being accomplished in many cases by the use of threaded fasteners or the like, which were readily susceptible to loosening, with a consequent loss of coupling between the individual terminated members. Where such single passage prior art devices further incorporated insulation piercing means such as tooth-like projections to permit the coupling thereof to electrically insulated conductors, the generally centrally disposed conductors were sufficiently isolated from the inner toothed surfaces of the connector to undesirably effect merely a partial engagement therewith, thereby resulting in an essentially incomplete connection.

SUMMARY OF THE INVENTION

The invention overcomes the problems and limitations noted above with respect to such prior art devices by providing a selectively formed, discretely deformable, multicompartment connector for securely coupling together a plurality of adjacently disposed discrete articles that is more effective, convenient, economical and versatile than such devices. A deformable base member comprising, in a preferred embodiment, an essentially flat planar member, is suitably formed to provide at least two discrete, independently deformable article receiving portions, each selectively arranged to form an article receiving cavity. Each receiving portion is selectively contoured to provide intimate engagement with

substantially the entire adjacent surface of an article positioned within the article receiving cavity thereof. The planar member may be variously configured in suitable arrangements to provide either substantially rectangular, arcuate, or U-shaped compartments, each of which may be appropriately formed to readily accommodate and be intimately deformable about one or more configurations of articles to be retained therein and readily intimately deformable thereabout. Mating locking tabs and recesses may be provided where desired to further increase the retention of the individual compartment walls about the internally contained articles. To enhance the use of the device as an electrical connector, insulation piercing teeth may be selectively disposed adjacent one or more of the compartment walls forming each of the article receiving portions and appropriately arranged to contact and engage the conductive portion of an insulated conductor adjacent thereto, the conductor engaging features of the device being substantially enhanced by the generally flat final configuration obtainable upon the deformation thereof, wherein, in the case where the device is employed for use with stranded insulated conductors, the conductors are caused to spread in essentially a single layer arrangement, thus advantageously exposing the maximum surface available for intimate engagement with the connector teeth. Thus, varying combinations of both solid and stranded conductors, in either rectangular, circular, or other commonly employed cross-sectional configurations may be effectively electrically coupled in secure adjacent relationship rapidly and economically. Each of the embodiments disclosed may be further provided with a suitably configured extending portion for either releasable or permanent attachment to a further member. The extension may comprise an apertured ring, forked tongue, mating male or female tab, or other commonly employed coupling arrangement according to the use thereof, formable either integral with the connector or as a separately attached portion thereof. For electrical purposes, the base member may be formed preferably from one of the commonly employed electrically conducting materials such as brass, copper, aluminum and the suitable compositions thereof. It is therefore an object of this invention to provide a multicompartment connector.

It is another object of this invention to provide a novel means for securely coupling a plurality of articles in adjacent relationship.

It is a further object of this invention to provide a means for securely intercoupling a plurality of variously configured articles.

It is still another object of this invention to provide a means for securely electrically intercoupling a plurality of variously configured insulated electrical conductors.

It is yet a further object of this invention to provide a connector having independently deformable article receiving compartments adapted to receive and retain a plurality of variously configured articles disposed therewithin.

It is yet another object of this invention to provide a novel multicompartment connector having a plurality of coupled discretely deformable, article receiving cavities, each of which is arranged to be intimately deformed about one of a plurality of differently con-

figured and sized articles, to establish secure inter-coupling therebetween.

Other objects and features of the invention will be pointed out in the following description and claims and illustrated in the accompanying drawings, which disclose, by way of example, the principle of the invention and the best mode contemplated for carrying it out.

BRIEF DESCRIPTION OF THE DRAWINGS

In the drawings:

FIG. 1 is a perspective view of a multicompartiment connector constructed in accordance with the concepts of the invention.

FIG. 2 is a perspective view of the device of FIG. 1 deformed about a plurality of wires.

FIGS. 3 through 6 are perspective views of other embodiments of a multicompartiment connector constructed in accordance with the concepts of the invention.

FIG. 7 is a perspective view of the device of FIG. 6 appropriately deformed about a plurality of differently configured conductors.

FIG. 8 is a perspective view of still another embodiment of a multicompartiment connector constructed in accordance with the concepts of the invention.

FIG. 9 is a perspective view of yet another embodiment of a multicompartiment connector constructed in accordance with the concepts of the invention.

FIG. 10 is a perspective view of yet a further embodiment of a multicompartiment connector constructed in accordance with the concepts of the invention.

FIG. 11 is a perspective view of the device of FIG. 10 deformably engaged about a plurality of wires.

FIGS. 12 through 15 are perspective views of still other embodiments of a multicompartiment connector constructed in accordance with the concepts of the invention.

Similar elements are given similar reference characters in each of the respective drawings.

DESCRIPTION OF THE PREFERRED EMBODIMENTS

Turning now to FIGS. 1 and 2, there is shown a multicompartiment connector 20 constructed in accordance with the concepts of the invention. Connector 20 comprises, essentially, a deformable base member 22 appropriately formed to define a series of generally flat planar members 24, 26, 28 arranged in a generally S-type configuration, substantially as shown, wherein each pair of adjacent opposing planar members, i.e., 24, 26 and 26, 28 are selectively arranged to define an article receiving portion 30 and 32, respectively, the opposing inner surfaces of planar members 24, 26 of portion 30 defining one article receiving cavity 34, and the opposing inner surfaces of planar members 26, 28 defining a second article receiving cavity 36. Extending along the free edge 38 of member 24 are a series of downturned spaced protrusions 40 arranged for cooperable locking engagement with an associated series of apertures 42 disposed along the opposing edge 44 of planar member 26, as is better seen in FIG. 2. A further series of protrusions 46 disposed along the free edge 48 of planar member 28 and associated mating apertures 50, disposed along the opposing edge 52 of planar member 26 are similarly arranged for inter-

locking engagement. Protruding into article receiving cavity 34 are a plurality of gripping teeth 54 depending from surface 56 of planar member 26, and arranged for intimate engagement with the adjacent surface of an article such as wires 58 (FIG. 2) disposed within article receiving cavity 34. Where wires 58 are insulated electrical conductors or the like, gripping teeth 54 may be suitably formed to provide insulation piercing surfaces obviating the need for stripping, cleaning, or otherwise separately exposing the conductive surface of the wires prior to their insertion and assembly within connector 20, where a secure electrical coupling is desired. Extending from surface 60 of planar member 28 and protruding into cavity 36 are similar gripping teeth 54 arranged and constructed in a manner similar to those disposed on surface 56 of planar member 26, providing further retaining and insulation piercing surfaces thereat where necessary or desirable. To effect an electrically secure coupling between adjacently disposed conductors such as 58 and 62 (FIG. 2), the ends of conductors 58 are inserted into one of the article receiving cavities 34, 36, and the ends of conductors 62 are inserted within the other of said cavities. The substantially planar members 24, 28 may then be simultaneously or individually compressively urged towards member 26, the ends of conductors 58 and 62 being thus effectively securely engaged and retained within their respective cavities, completing the coupling therebetween, teeth 54 piercing the outer surface of conductors 58, 62 and at least partially embedding themselves therewithin. Upon the compressive deformation of device 20, protrusions 40, 46 are caused to engage apertures 42, 50, respectively, further securing the opposing members 24, 26, 28 in coupled engagement. It should be noted that the uniquely formed generally flat configuration of connector 20, as shown in FIG. 2, advantageously encourages a substantially flat, single-layered dispositional arrangement of the conductors enclosed therewithin with the subsequent exposure of at least a portion of the surface of virtually all of the retained conductors for intimate engagement with the respective adjacent planar member surfaces, affording an extremely high degree of electrical coupling thereby. The elemental construction of connector 20, as shown in FIGS. 1 and 2, may be readily modified, as shown, for example, in FIGS. 3 through 7, while maintaining the generally flat multicompartiment structure thereof. In FIG. 3, connector 64 comprises three generally over-lapping, adjacently disposed, spaced, planar members 66, 68, 70 forming a somewhat modified, flattened G-shaped structure and providing two juxtaposed article receiving cavities 72, 74, cavity 72 being defined by the adjacent opposing surfaces 76, 78 of members 66, 68, respectively, and cavity 74 being similarly defined by the adjacent opposing surfaces 80, 82 of members 68, 70, respectively. The selectively formed protrusions 84 disposed along the free end 86 of member 66 are arranged to lockingly engage the associated adjacent apertures 88 in member 68 in a manner similar to that described above with respect to elements 40 and 42 of FIGS. 1 and 2. Further locking of members 68 and 70 may be achieved upon the interengagement of selectively proportioned protrusions 90 adjacent the free end of member 68 with their mating apertures 92 suitably disposed along the

web portion 94 connecting members 66 and 70. The adjacent opposing surfaces 80, 82 partially defining cavity 74, and the inwardly directed surface 76 of member 66 have disposed thereon a plurality of teeth 96 essentially equivalent to teeth 54 of connector 20 (FIG. 1). In use, connector 64 may be advantageously employed in substantially the same manner as described above with respect to connector 20. In FIG. 4, connector 98 is shown as comprising four spaced, overlapping, adjacently disposed planar members 100, 102, 104, 106, respectively, members 100 and 102 defining a first article receiving cavity 108, members 102 and 104 defining a second article receiving cavity 110, and members 104 and 106 defining a third article receiving cavity 112. Although only two of the three cavities are shown as being provided with teeth such as 114, it should be clear that the third cavity 110 may be so enhanced by the selective disposition of further teeth 114 adjacent the opposing spaced surfaces 116, 118 of members 102, 104, respectively, where necessary or desirable, and within the concepts disclosed herein. Protrusions 120 and mating apertures 122, adjacent the edges of connector 64, are essentially duplicative of similar elements 84, 88 and 40, 42 of connectors 64 and 20, respectively, providing increased locking engagement between the adjacent planar members of connector 98 as it is compressively deformed about the articles (not shown) engaged within the cavities thereof. In FIG. 5, the base member 121 of connector 123 illustrated therein is suitably formed to provide four overlapping, spaced, generally planar members 124, 126, 128, and 130, defining an upper article receiving cavity 132 and a lower article receiving cavity 134, each being independently deformable about an article or articles inserted therewithin. A series of protrusions 136 disposed adjacent a web portion 138 intermediate members 124 and 126 are arranged for locking engagement with an associated series of apertures 140 in a manner similar to that described heretofore. Depending outwardly from member 124 is an extending portion 142 which may be apertured as at 143 to permit the receipt therethrough of a fastening means (not shown) wherein connector 123 may be appropriately coupled to a further member such as a terminal board or another connector (not shown). It will be apparent to those skilled in the art that the extending portion 142 of connector 123 may be appropriately configured to provide various other suitable shapes as, for example, a resilient tab receiving receptacle 144 (FIG. 14), or forked terminal 146 (FIG. 15). Further, the extending portion 142, although shown as extending outwardly in generally longitudinal axial alignment with the base member 121, may be positionally oriented in any one of a number of other suitable arrangements, either axially or planarly, as desired, and may comprise a plurality of such portions 142 coupled either to one or both ends of connector 123, or any of the other modifications thereof, within the concepts herein, and without departing from the spirit of the invention. In FIGS. 6 and 7, the deformable, partially toothed base member 148 has been formed in a somewhat accordian-like arrangement providing four generally parallel, adjacently disposed, discrete article receiving cavities 150, 152, 154, 156. The free ends 151, 153 of base member 148

are suitably formed to partially overlie the cavities 150, 152, 154, 156 and are arranged for meshing interengagement, the serrations 158 disposed adjacent the upwardly facing surface 160 of free end 151 being adapted to interlock with the complementarily formed serrations 162 disposed adjacent the mating, downwardly facing surface 164 of free end 153 upon the compressive deformation of base member 148, as may be more clearly seen in FIG. 7. Conductors 166, 168, 170 and 172, interposed within their associated cavities in base member 148, are thus securely retained therewithin and advantageously electrically and mechanically coupled together. Although base member 148 is depicted as being suitably formed to provide four article receiving cavities, it will be apparent to those skilled in the art that the number of cavities may be readily increased or decreased as desired, without degrading the utility or versatility of the connector.

Referring now to FIG. 8, there is shown a further embodiment of a multicompartment connector 174 constructed in accordance with the concepts of the invention. The deformable base member 176 is initially formed essentially as a partitioned tube comprising a generally centrally disposed planar member 178 intermediate a pair of arcuate members 180, 182, forming two semi-annular discrete article receiving cavities 184, 186. Each cavity 184, 186 is further laterally divided by a partition 188, 190, respectively, each partition being formed from a portion of its respective arcuate member and folded inwardly towards the generally central planar member 178, which is preferably apertured, as at 192, to provide for the receipt therein of the respective free ends 194, 196 of partitions 188, 190 upon the compressive deformation of arcuate members 180, 182 towards planar member 178, thereby providing essentially four individual compartments. Further partitions such as 188, 190 may be provided, or such partitions may be eliminated completely, where so desired, thereby selectively increasing or decreasing the number of available compartments. The article gripping teeth 198, shown depending from the cavity defining surfaces of each of the members 178, 180, 182, perform essentially as described heretofore, and may be eliminated, if desirable or necessary, without affecting the basic utility of the connector 174.

Referring now to FIG. 9, a toothed, deformable base member 200 is uniquely formed in spiral-like fashion to provide a plurality of generally arcuate article receiving cavities such as 202, 204, 206, each suitably adapted to receive a selective plurality of the free ends of variously configured conductors such as 208, 210, and 212, and readily deformable thereabout, providing rapid and convenient electrical and mechanical coupling therebetween.

Turning now to FIGS. 10 through 15, there are shown further embodiments of a multicompartment connector constructed in accordance with the concepts of the invention. In FIG. 10, the toothed base member 216 of connector 214 is selectively formed to provide a pair of U-shaped members 218, 210 disposed in substantially back-to-back arrangement, defining a generally H-type configuration, as shown, providing two independent, adjacently disposed article receiving cavities, 222, 224. The opposing side walls 226, 226' of the upper U-shaped member 218 and the opposing side

walls 228, 228' of the lower U-shaped member 220 are readily deformable inwardly, as is more clearly seen in FIG. 11, thereby engaging the free ends 230 and 232 of cables 234 and 236, respectively, therewithin and providing a secure connection therebetween. The positional arrangement of U-shaped members 218 and 220 may be modified as shown in FIG. 12 wherein the members 218, 220 are disposed in substantially colinear adjacent relationship, providing a generally end-to-end connector 238. The embodiments of FIGS. 10 and 12 may be effectively combined, substantially as shown in FIG. 13, to provide a unique, versatile, multicompartment connector 240, providing for both parallel and end-to-end mechanical and electrical coupling between adjacently disposed articles. Connector 214 may be further modified, as shown, for example, in FIGS. 14 and 15, to include an extending portion such as 144 adjacent one end of connector 242 in FIG. 14 and 146 adjacent one end of connector 244 in FIG. 15, as described heretofore.

The embodiments of the invention in which an exclusive property or privilege is claimed are defined as follows:

1. A multicompartment electrical connector comprising: a deformable metallic base member having at least three independently movable, hingedly intercoupled partitions said partitions forming at least two discrete article receiving cavities said article receiving cavities being separated one from another by at least one of said partitions, the respective partitions forming one of said article receiving cavities being closable one upon another independently of said partitions forming

the remainder of said article receiving cavities.

2. A connector as defined in claim 1 wherein said base member is formed from electrically conducting material.

3. A connector as defined in claim 1 wherein at least one of said partitions is formed to define a substantially flat planar member.

4. A connector as defined in claim 1 wherein at least one of said partitions is substantially arcuate.

5. A connector as defined in claim 1 wherein said partitions are arranged to form at least two generally U-shaped article receiving cavities.

6. A connector as defined in claim 1 further comprising an extending portion adjacent at least one end of at least one of said partitions for coupling said connector to a further member.

7. A connector as defined in claim 1 further comprising locking means for securing said partitions in locked interengagement.

8. A connector as defined in claim 7 wherein said locking means comprises at least one protruding portion and at least one complementary recess disposed in adjacent mating relationship.

9. A connector as defined in claim 1 further comprising a plurality of teeth disposed adjacent at least a portion of at least one surface of at least one of said partitions.

10. A connector as defined in claim 9 wherein said teeth are disposed adjacent at least a portion of at least one surface of each of said partitions.

* * * * *

35

40

45

50

55

60

65