

Feb. 18, 1941.

P. ZALKIND

2,231,982

COLLAPSIBLE FILLER

Filed April 20, 1936

5 Sheets—Sheet 1

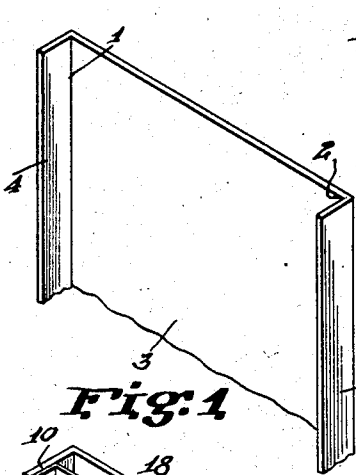

Fig. 1

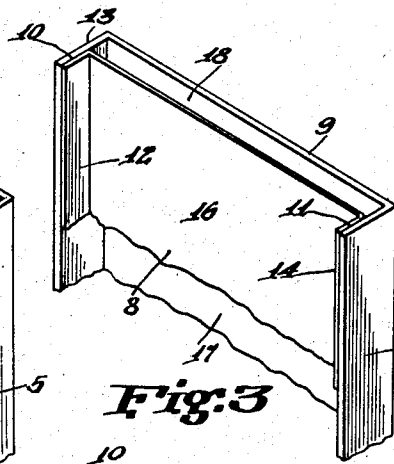

Fig. 3

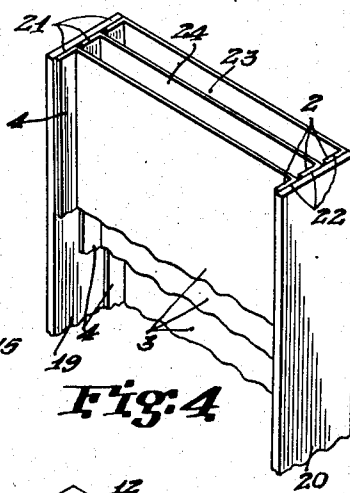

Fig. 4

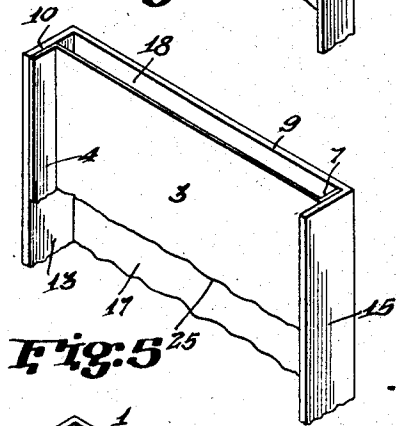

Fig. 5

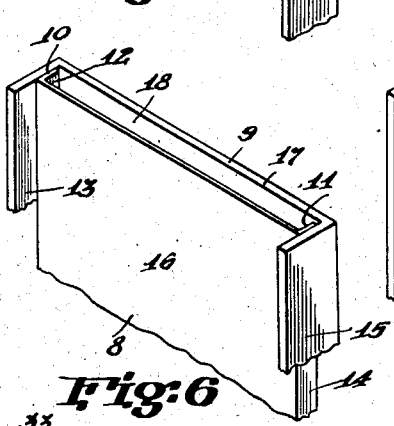

Fig. 6

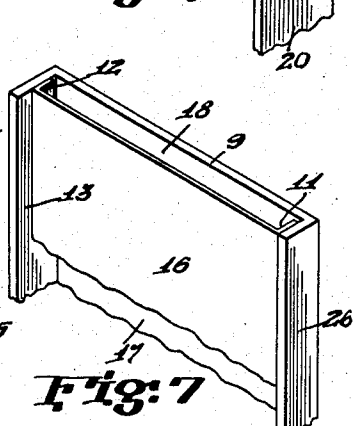

Fig. 7

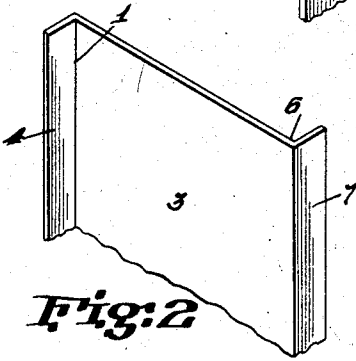

Fig. 2

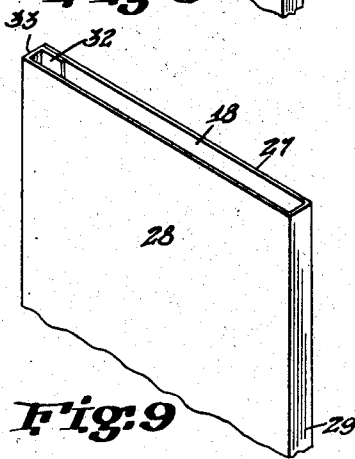

Fig. 9

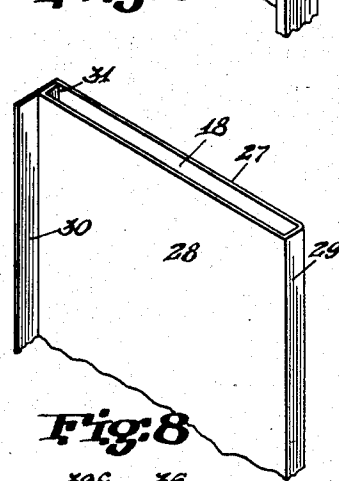

Fig. 8

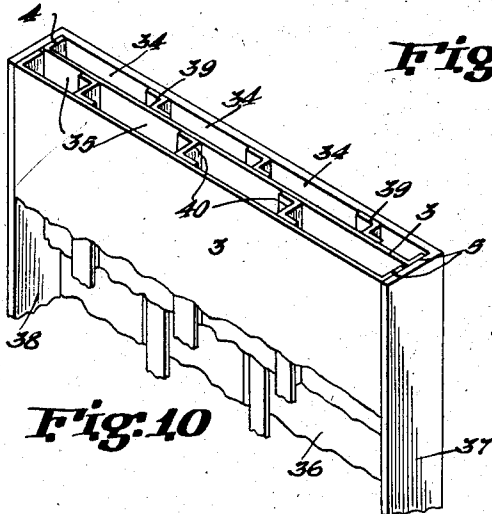

Fig. 10

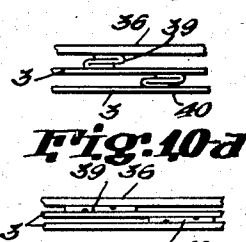

Fig. 10a



Fig. 10b

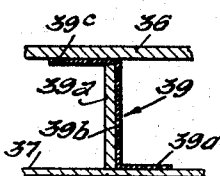

Fig. 10c

INVENTOR.  
Philip Zalkind  
BY Samuel Ostrolenk  
ATTORNEY.

Feb. 18, 1941.

P. ZALKIND

2,231,982

COLLAPSIBLE FILLER

Filed April 20, 1936

5 Sheets-Sheet 2

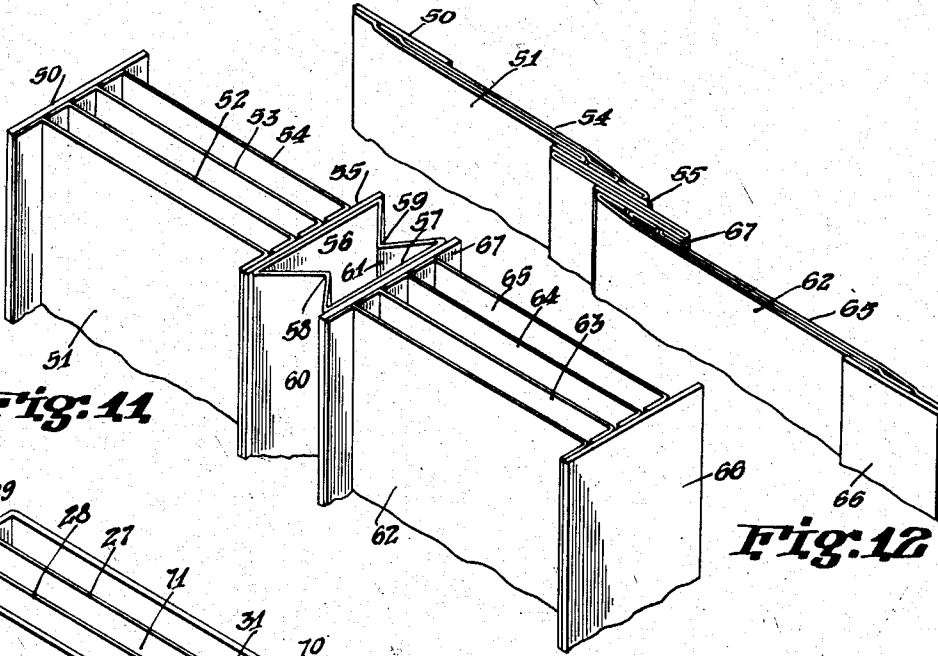

Fig. 11

Fig. 12

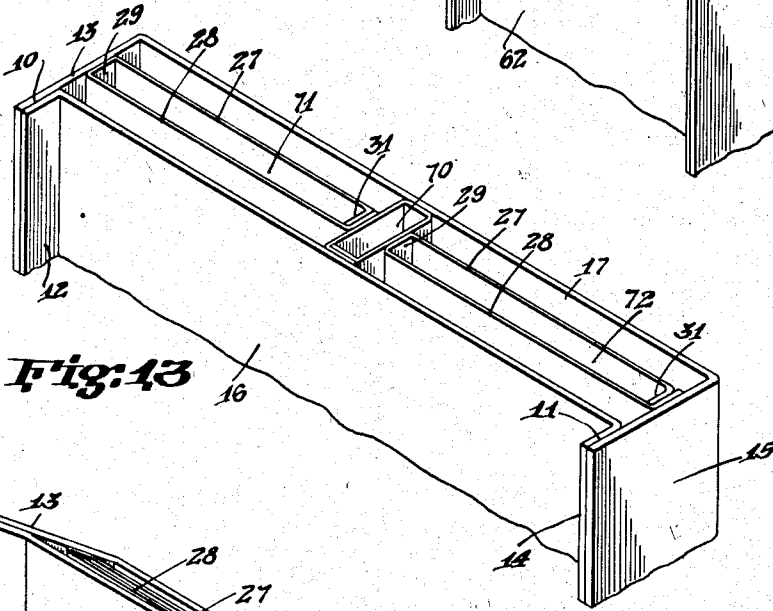

Fig. 13

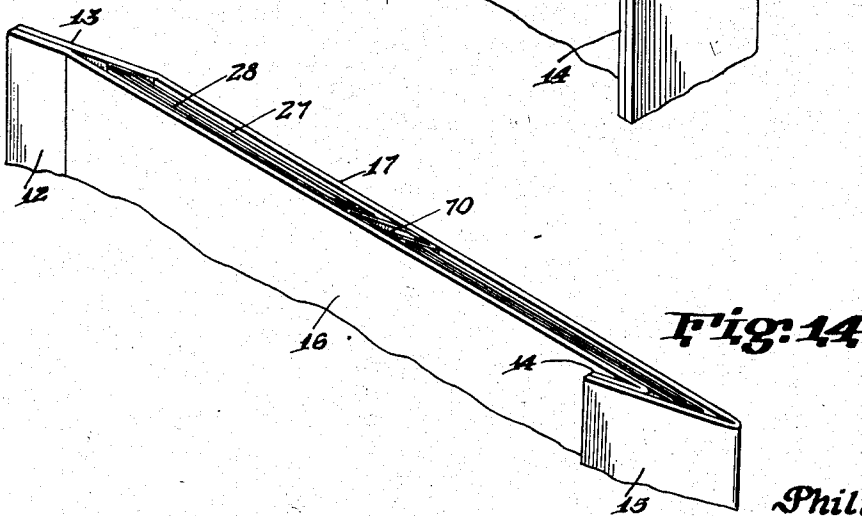

Fig. 14

INVENTOR.  
*Philip Zalkind*

BY

*Samuel Ostrolenk*  
ATTORNEY.



Feb. 18, 1941.

P. ZALKIND

2,231,982

COLLAPSIBLE FILLER

Filed April 20, 1936

5 Sheets-Sheet 4

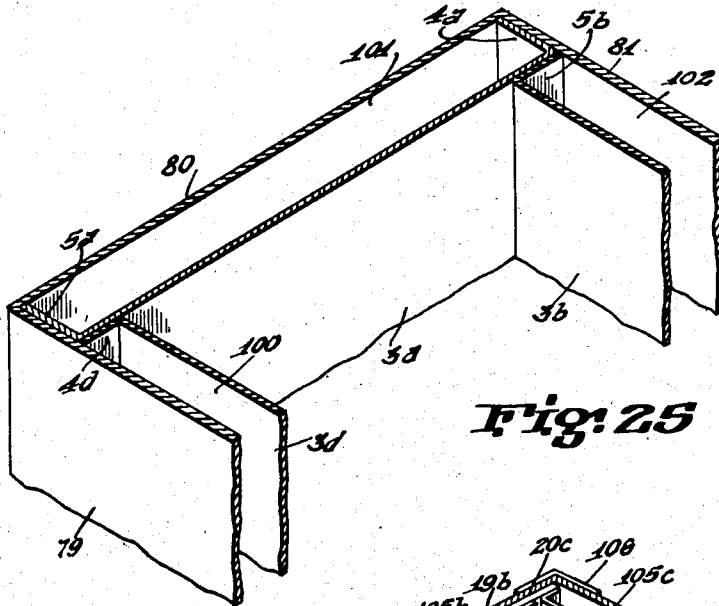

Fig: 25

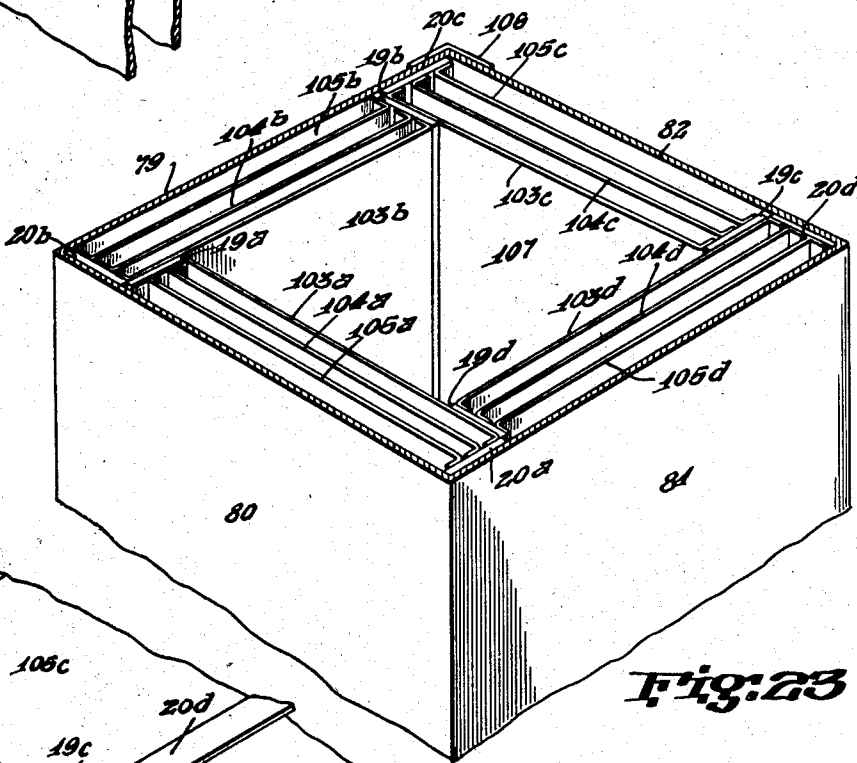

Fig: 23

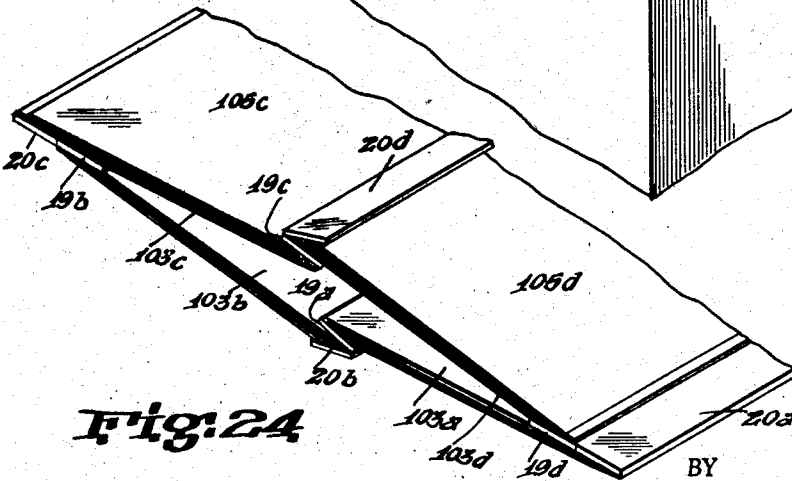

Fig: 24

INVENTOR.  
*Philip Zalkind*  
BY *Samuel Ostrofsky*  
ATTORNEY.

Feb. 18, 1941.

P. ZALKIND

2,231,982

COLLAPSIBLE FILLER

Filed April 20, 1936

5 Sheets-Sheet 5

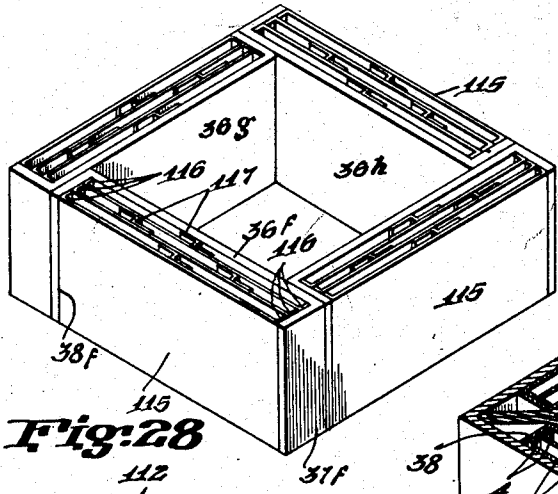

Fig:28

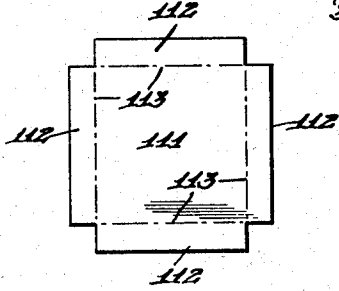

Fig:29

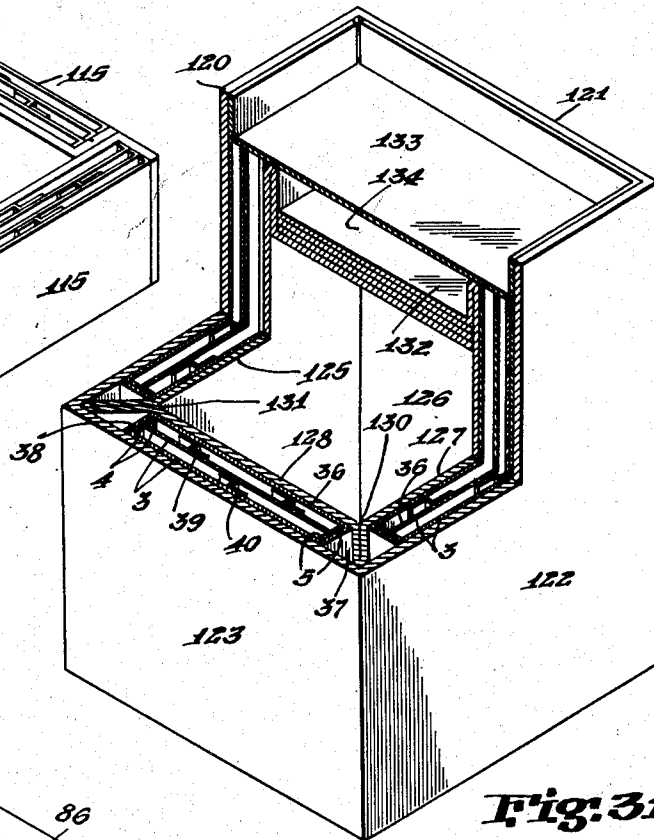

Fig:31

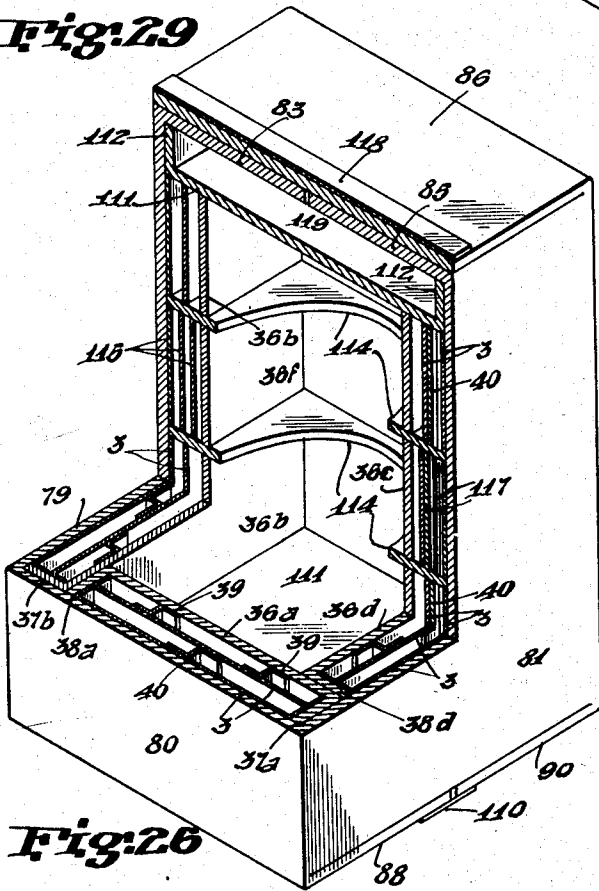

Fig:26

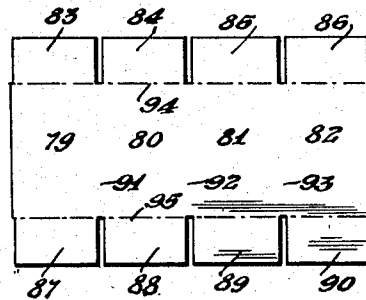

Fig:27

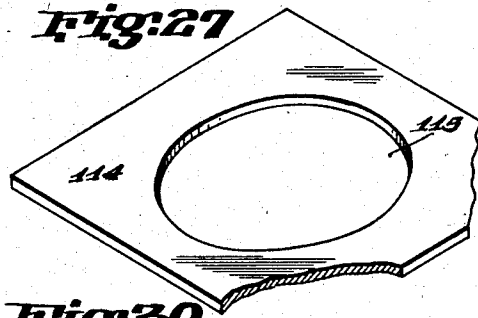

Fig:30

INVENTOR.  
*Philip Zalkind*  
 BY *Samuel Ostrolenk*  
 ATTORNEY.

# UNITED STATES PATENT OFFICE

2,231,982

## COLLAPSIBLE FILLER

Philip Zalkind, New York, N. Y.

Application April 20, 1936, Serial No. 75,314

2 Claims. (Cl. 229-14)

My invention relates to novel heat insulation members, and more particularly to collapsible members of sheet material adaptable for use with casings, wherein it is desired to control or maintain temperature, and exclude or conserve heat.

My invention comprises novel combinations of simple forms of sheet material, such as corrugated board, straw board, box board, paper, metal foil, paper backed foil and the like, by which I obtain a collapsible structure, which when expanded produce one or more "dead air" spaces to act as insulation. By this means transfer of heat is so effectively reduced that a casing with this insulation may be used in the transportation, and/or storing of such materials as ice-cream.

As will be clearly shown later herein my novel insulating members may be formed from a few simple fundamental shapes, which may be united in various combinations to form collapsible insulating units, which may by themselves be used as insulating fillers in a suitably constructed casing, as, for instance, the casings shown in my copending applications filed coincidentally with this application and entitled, Collapsible insulating casing, Serial No. 75,315, Set-up insulating box, Serial No. 75,317.

I have also found that sections of the various forms of my collapsible insulating units, to which I have referred, may be united with each other to form a collapsible insulating form which may be used with folding casings of many well-known types, which are themselves not designed or intended for insulating service. By the use of my insulating form, as will be clearly shown, these common shipping containers become adapted to the shipment of substances which must be maintained at temperatures appreciably different from that of the atmosphere.

All of the various fundamental sections entering into my construction, as well as the composite sheets or units which I form by various combinations of these fundamental sections, are easily and quickly produced. The fundamental sections are several shapes of scored blanks, or simple rectangular tubes which may be manufactured according to present common practice. Also various forms of my insulating sheets may be made quickly and cheaply in a continuous process as I show in my copending application entitled Method of producing insulation sections, Serial No. 75,318 and filed coincidentally with this application.

Objects of my invention are thus to provide a collapsible insulating filler for casings, which filler may be expanded to form "dead air" spaces

having a high heat insulating value. Other objects of my invention are to provide an insulating filler that is of low cost, that is simple and easy to construct, that requires little space for storing and shipping. There are other objects of my invention which will be apparent from the detailed description in connection with the attached drawings, which form a part of this specification and which are enumerated as follows:

Figure 1 is a fragmentary perspective view of one of the fundamental shapes of U shaped cross-section, such as I use in the construction of my insulation.

Figure 2 is a fragmentary perspective view of another of the fundamental shape of Z shaped cross-section.

Figure 3 is a fragmentary perspective view showing one form of my insulating sheet as formed by uniting two sheets, each having the general form of the fundamental shape shown in Figure 1.

Figure 4 is a fragmentary perspective view showing a modified form of my insulating sheet similar to that shown in Figure 3, except that it is formed from three sheets of the general form shown in Figure 1.

Figure 5 is a fragmentary perspective view similar to Figure 3, except that the insulating sheet is formed by uniting one sheet having the general form of the fundamental shape shown in Figure 1, and one sheet having the general form the fundamental shape shown in Figure 2.

Figure 6 is a fragmentary perspective view similar to Figure 3, except that in Figure 6 the position of one sheet is reversed with respect to the other.

Figure 7 is a fragmentary perspective view similar to Figure 6, except that in Figure 7 the two outstanding legs on one of the fundamental sections are of different lengths.

Figure 8 is a fragmentary perspective view of a form of insulating member having the same general outline as the member shown in Figure 7, but formed from a single sheet of material.

Figure 9 is a fragmentary perspective view of a form of insulating member similar to that shown in Figure 8, but not provided with an outstanding flange.

Figure 10 is a fragmentary perspective view showing a form of my insulating sheet built up from a plurality of fundamental sections similar to that shown in Figure 1, and reinforced with a plurality of sections similar to the fundamental form shown in Figure 2.

Figure 10a is a fragmentary end view of the

form of insulating unit shown in Figure 10 after the unit has been collapsed in one direction.

Figure 10b is a fragmentary end view similar to Figure 10a showing the insulating unit collapsed in the other direction.

Figure 10c is an enlarged sectional view through one of the spacer members of Figure 10 showing a modified form of construction.

Figure 11 is a fragmentary perspective view showing a further modified form of my insulating sheet which is formed from a plurality of sections.

Figure 12 is a fragmentary perspective view showing the insulating section of Figure 11 in collapsed condition.

Figure 13 is a fragmentary perspective view showing a further modified form of insulating sheet produced by combining the form of sheet of Figure 3 with the form of section of Figure 9.

Figure 14 is a fragmentary perspective view showing the sheet of Figure 13 in collapsed condition.

Figure 15 is a fragmentary perspective view showing a rectangular unitary insulating form produced by uniting four insulating sections of the type shown in Figure 3. Figure 15 shows this form being entered into a rectangular casing.

Figure 16 is a fragmentary perspective view showing the unitary form of Figure 15 in a collapsed condition.

Figure 17 is an end view showing a form of rectangular unitary insulating form produced by uniting four sections similar to those shown in Figure 1.

Figure 18 is an end view showing the insulating form of Figure 17 in collapsed condition.

Figure 19 is an end view similar to Figure 17, except that it shows a different arrangement for combining the fundamental sections which comprise the form.

Figure 20 is an end view showing the insulating form of Figure 19 in collapsed condition.

Figure 21 is an end view showing a rectangular unitary insulating structure produced by uniting four sections similar to those shown in Figure 9.

Figure 22 is an end view showing the insulating form of Figure 21 in collapsed condition.

Figure 23 is a fragmentary perspective view showing a rectangular unitary insulating structure inserted within a rectangular casing.

Figure 24 is a fragmentary perspective view showing the insulating structure of Figure 23 in partially collapsed condition.

Figure 25 is a fragmentary sectional perspective view showing the manner in which the unitary form of Figure 17 may be inserted within a rectangular casing.

Figure 26 is a fragmentary perspective view showing a rectangular casing completely insulated with my novel sections.

Figure 27 shows a developed blank for forming the casing of Figure 26.

Figure 28 is a fragmentary perspective view showing one of the unitary insulating members shown in place within the casing of Figure 26.

Figure 29 is a developed blank for forming one of the end seals shown in Figure 26.

Figure 30 is a fragmentary perspective view showing a spacing member as is shown in Figure 26.

Figure 31 is a fragmentary perspective view showing my insulating sections interposed within the air space of one form of my insulating casing.

In Figure 1 I have shown one of the fundamental shapes that I use to form my novel in-

ulating sheets. As shown, this shape is formed from a single sheet of material having the score lines 1 and 2. The sheet is bent on these score lines to form a channel having the web 3 and the flanges 4 and 5.

In Figure 2 I have shown another one of the fundamental shapes that I use to form my novel insulating units. This form is similar to that shown in Figure 1, except that one of the flanges is bent in the opposite direction from that of the other flange, thus forming a Z shaped section having the web 3 and the flanges 4 and 7. It will be noted that Figures 1 and 2 are substantially alike, except that score line 6 in Figure 2 is preferably on the opposite side of the sheet 15 from score line 1; while in Figure 1 both score lines are preferably on the same side of the sheet. This facilitates bending the flanges into their intended directions; the arrangement and character of scores will vary with various material conditions according to practices well known in the art.

In Figure 3 there is shown an insulating section formed from two fundamental sections having the same general shape as the section shown in Figure 1. Member 8 is united with member 9, preferably by the glue lines 10 and 11, the flange 12 of member 8 being secured to the longer flange 13 of member 9 by the glue line 10, and the flange 14 of member 8 being secured to the longer flange 15 of the member 9 by the glue line 11. Flanges 12 and 14 are shown to be of practically the same length as each other. Flanges 13 and 15 are likewise of equal length to each other. An air space 16 is formed between the web 16 of member 8 and the web 17 of member 9. Also, when the edges of the flanges are laid against a flat surface, an additional air space is formed between that surface, the flanges and the web 16, as is clearly shown in Figure 15. The materials of sheets 8 and 9 forming the section will depend upon the particular use to which the insulating sheet is to be put. Thus, as an example, sheet 9 may be of relatively strong and heavy material, such as corrugated board, while sheet 8 is of lighter material, such, for example, as chip board, box board or paper. It will, of course, be understood that both sheets may be formed from the same kind of stock, and that other materials may be used than those specifically mentioned above.

In Figure 4 I have shown a modified form of insulating section utilizing three of the fundamental sections of Figure 1 united with two plain strips of sheet material. Thus flanges 4 are united with the sheet 19 by the glue strips 21, and flanges 2 are united with the sheet 20 by the glue strips 22. In this manner an insulating unit is formed having the two air spaces 23 and 24, and capable of forming an additional air space when the edges of the flanges are placed against a flat surface, as has been explained in connection with Figure 3. It will be noted that while the figure shows three sections similar to those of Figure 1 united with the plain sheets, any number of such sections may be so united, and the number of air spaces so formed will be one less than the number of channel shaped sheets used in the construction. However, in co-action with a container wall the number of air spaces equals the number of sheets, as will be shown later. In this manner the insulating properties of the unit may be varied at will, more air spaces being provided where higher insulating values are needed.

In Figure 5 I have shown a form of insulating unit using one sheet 9 having the shape of that

shown in Figure 1, and a second sheet 25 having the shape of that shown in Figure 2. As shown, sheet 9 and sheet 25 are united by means of their flanges. The combined unit so formed includes an insulating air space, and the unit has the same general form as that shown in Figure 3 produced from two channel shaped members.

Another similar form is also shown in Figure 6. Like Figure 3, the form shown in Figure 6 is produced from two channel shaped members. However, while the flanges 12 and 14 of the inner member of Figure 3 are turned in the same direction as are the flanges 13 and 15 of the outer member; as shown in Figure 6, the flanges 12 and 14 are turned in the opposite direction to the flanges 13 and 15. The form of Figures 3, 5 and 6 may be used interchangeably as insulating units, as well as in combinations forming more complex insulating structures in a manner to be later described, as in each case for the same dimensions equivalent air space 18, equivalent insulating effect and equivalent collapsibility will be secured. The forms shown in Figures 3 and 6 are readily assembled in a continuous manner using the method and apparatus of my copending application previously referred to. However, if the parts are manually secured to each other, the form shown in Figure 6 is somewhat more easily made than the form shown in Figure 3. Thus, in manually combining the form of unit shown in Figure 6, flange 13 may be first bent out of the plane of the web 17. This forms an angle which acts as an automatic stop in positioning flange 12. Flange 12 may be bent out of the plane of web 16 and have glue applied thereto. It may be then pushed into position against flange 13. When the free edge of flange 12 comes into abutting relationship with the angle formed by flange 13 and web 17, then the two sheets forming the section are in proper position in relationship to each other.

In Figure 7 substantially the same construction is shown as is shown in Figure 6. However, in Figure 7 one of the outstanding flanges of the outer sheet 9 has its free edge flush with the web 16 of the inner sheet. Thus in Figure 7 the flange 26 is cut off flush with the face of web 16, while in Figure 6 the flange 15 protrudes beyond the face of web 16. It will be further understood that both flanges may end flush, so that the section formed is substantially rectangular in cross-section. The preferred length of flange will in each instance depend upon the particular application material used, and specific method of assembling and combining the units.

Where a section, such as that shown in Figure 7, is desired, and where the requirements of the unit is such that material of substantially uniform quality and thickness may be used, the unit may be formed from a single sheet of material as is shown in Figure 8. The air space 18 is formed between the webs 27 and 28 and the ends 29 and 30. The end 30 extends beyond the web 28 in the same manner as flange 13 extends beyond web 16 in Figure 7. As is shown in Figure 8 the two ends of the sheet are united through glue flap 31 on web 28, and flange 30 on web 27.

Figure 9 is similar to Figure 8, except that no extended flange is provided in Figure 9, and that the two ends of the sheet are united with each other through the flap 32 attached to the end flange 33. Flap 32 is positioned to be pasted to the free edge of web 27. This form is particularly adaptable to a member which is provided

with end scoring to produce an additional fold, as will be described later in connection with Figures 11 and 12.

In the structures shown in Figures 8 and 9 the unit formed is, of course, of material of substantially uniform quality and thickness, as each is formed from a single sheet of material. Where in a form, such as is shown in Figures 3 and 5, the requirements of the particular adaptation are such that material of substantially uniform quality and thickness may be used, these forms may, like Figures 8 and 9, be formed from a single sheet of material. Thus, for instance, in Figure 5, flange 4 and flange 13 may be joined to each other at their extremities, the unit thus being formed from a continuous sheet of material.

In Figure 10 I have shown an insulating unit having two air spaces 34 and 35 parallel with the surface of the sheets forming the section. As shown the principal members of the section are the channel shaped sheets of Figure 1. One sheet 36 has its flanges 37 and 38 turned outwardly, and the other two sheets have their flanges 4 and 5 turned inwardly in the same manner as is shown in Figure 6. One air space 34 is formed between sheet 36 and the inner diaphragm 3. The other air space 35 is formed between the two diaphragms 3. In order to brace the diaphragms, the Z sections 39 and 40 are provided. The sections are similar in shape to the form shown in Figure 2. One flange of each of the braces 39 is attached to sheet 36, and the other flange is attached to the inner diaphragm 3. One of the flanges of each of the braces 40 is attached to the inner diaphragm 3, and the other flange is attached to the outer diaphragm. With this construction, while the diaphragms are adequately braced, and so may be maintained in predetermined spacings, even though made of lighter material than otherwise, the section is easily collapsible, as the whole assembled structure, including the braces, may be flattened, and the various parts may swing on the score lines, as may easily be seen, and as is more fully explained in connection with Figures 10a, 10b and 10c. Members 39 and 40, in addition to bracing the diaphragms, also serve to subdivide the air spaces 34 and 35, and so act to reduce any possible convection currents within these spaces.

In collapsing the structure of Figure 10 the parallel diaphragms may be moved in either direction with respect to each other. Thus, if it is assumed that the outer membrane 36 is held stationary, if the inner membrane is displaced to the left, the unit will fold with each spacer member doubled back upon itself, as shown in Figure 10a; if the inner membrane is displaced to the right, the unit will fold with each spacer flattened out, as shown in Figure 10b. In making up the unit, I prefer that the spacers be folded, as shown in Figure 10a, as with the spacers so folded, any glue improperly applied in the gluing operation does not act to prevent expansion of the section. Also with the spacers folded as in Figure 10a, the expansion of the unit is somewhat easier than when the unit is collapsed, as is shown in Figure 10b, as the elasticity of the spacer units tends to expand the unit with this folding when each spacer is a single piece of material. However, with the method of folding, as shown in Figure 10b, the unit will occupy less volume in the collapsed state than when folded, as shown in Figure 10a. However, with the construction of spacers, as shown in Figure 10c, this difference in volume will not be appreciable.

In Figure 10c, the spacer 39 is shown as being formed from two separate sheets of material. One sheet 39a of cardboard, corrugated board or similar sheet serves as the proper spacer. Secured to this is the sheet of paper 39b having the extensions 39c and 39d which serve to unite the spacer with the adjacent diaphragms. Thus, as shown, extension 39c serves to unite the spacer with sheet 36, and extension 39d serves to unite the spacer with sheet 3.

In the construction of an insulating section, such as is shown in Figure 10, not only may the various parts be of different thicknesses, but, also various construction materials may enter into the same insulating section. Thus, for example, I may use corrugated board for panel 36 with its integral flanges 37 and 38, cardboard for the spacing members 39 and 40, and polished metal foil or paper-backed foil for the webs 3. With the use of polished metal foil or paper-backed foil in this manner, I secure not only the advantageous air spaces which provide insulation against convection and conduction, but also obtain effective insulation against radiated heat. This application of radiating surfaces may be used with other modifications of my collapsible insulating section. It will be noted where the spacing members, such as 39 and 40 of Figure 10, are used in connection with the diaphragms 3 constructed of metal foil, that these spacing members act to support the foil and maintain the diaphragm in a substantially plane surface.

It will be noted that the shapes shown in Figures 1, 2, 8 and 9 are formed from a single sheet of material, and with various dimensions are the fundamental shapes from which my insulating units and other structures may be made. These sheets and structures may comprise various combinations depending upon the purpose and the particular application for which it is intended. Thus in Figures 3, 5, 6 and 7 I show an insulating sheet of simple form comprising only two separated members united with each other. In Figures 4 and 10 a fuller arrangement of parts is shown to produce an insulating unit. Other arrangements of the parts may be assembled as will readily suggest themselves from the foregoing. As will now be shown, various forms of sheets may be combined with each other to produce other forms of insulating units, or to produce complete insulating structures which, for most applications, are preferably of quadrilateral form.

In Figure 11 I have shown an insulating unit built up from several of the forms similar to those already described. Thus the portion formed by the sheets 50 and 55 and the channels 51, 52, 53 and 54 is similar to the unit shown in Figure 4. The portion comprising the sheets 66 and 67 and the channels 62, 63, 64 and 65 is likewise similar to that in Figure 4. These two portions are united with each other through the centre member having the sides 56, 57, 60 and 61 of similar construction to the member shown in Figure 9. That is, the centre member is inherently a quadrilateral structure. The opposite sides 60 and 61 are provided respectively with the score lines 58 and 59 on which the sheet may be folded to form the bellows shaped structure shown in Figure 11. Side 56 of the bellows is united with sheet 55 as by gluing; and side 57 of the bellows is united with sheet 67 in a similar manner. This construction may be repeated. That is, a bellows shaped member, as shown in the centre of the unit, may be attached to the end of the unit. To this bellows may be attached an additional

member, such as that formed from sheets 50 and 55 and channels 51, 52, 53 and 54. Thus the unit may be extended by alternate forms for any length as may be desired. The advantage of this construction lies in the ease with which the section may be adjusted to various lengths and conditions, without any change in the construction of the section, as can readily be seen in Figure 11. Thus the section may be stretched until each half of the side 60 on each side of the score line 58 lies in a single plane, and, similarly, each half of the side 61 on each side of the score line 59 lies in a single plane. On the other hand, the section may be contracted until the two halves of sides 60 and 61 respectively are in face to face relationship with each other. Thus the length of the entire section may be easily changed by substantially the length of the sides 60 and 61 merely by expanding or compressing the bellows section formed by these sides. It will also be noted that the form of section shown in Figure 11 is capable of taking an angular conformation by expanding one of the sides of the bellows more than the other side. Thus, for instance, the side 60 may be folded upon itself so that the near edge of members 55 and 67 (as viewed in Figure 11) may be substantially in contact with each other, while side 59 is fully expanded, thus placing diaphragm members 51, 52, 53 and 54 at a substantial angle to diaphragm members 62, 63, 64 and 65, while still maintaining the members 50 and 55 perpendicular to the diaphragms 51 to 54, and members 66 and 67 perpendicular to the diaphragms 62 to 65. In this way maximum air spaces may be maintained even with the two ends in angular relationship to each other. As is shown in Figure 12, the structure of Figure 11 may be readily collapsed, but when expanded and properly placed within a supporting shell, it readily holds its expanded form as will be seen later.

In Figure 13 I have shown one manner in which the form of unit shown in Figure 3 may be modified to provide additional air spaces, and therefore additional insulation over the simple form of unit shown in Figure 3. It will be noted that three insulating forms, similar to that shown in Figure 9, are incorporated into the air space 18 of Figure 3 to produce the form of insulating unit shown in Figure 13. In this manner there is produced an insulator having three air spaces parallel with the surface of the sheet. Any heat transferred perpendicular to the sheet must therefore pass through these three air spaces in series. As shown in Figure 13, the quadrilateral member 70, having a dimension to correspond to the total width of the air space formed between the sides 16 and 17, is placed in this air space at, for instance, midway between the two ends of sides 16 and 17. One end of member 70 is united with sheet 16, and the other end of member 70 is united with sheet 17, a suitable adhesive being preferably used for this purpose. The quadrilateral member 71 is then placed in the air space, its length being such as to extend from the inner surface of the end flange 13 of sheet 17 to the surface of the nearer side wall of member 70. Member 71 is suitably affixed by its end walls to flange 13 and member 70. In a similar manner member 72 is affixed between the flange 15 and the second side wall of member 70. When properly placed in a suitable rectangular container, this insulating structure shown in Figure 13, will be held in expanded condition and will be able to withstand considerable pressure against

either side wall without any danger of collapsing. However, when this unit is removed from its container, it may be easily collapsed despite the relative complexity of the section, just as the more simple forms may be collapsed when so required. This is clearly shown in Figure 14.

As has been previously indicated, various sections of my insulating units may be combined with each other to form a collapsible insulating tube, which may be readily inserted into a suitable casing. In Figure 15 I have shown a tube formed from four sections similar to that shown in Figure 3. Thus one section comprises the inside wall member 17a with flanges 13a and 15a, joined to the outside wall member 16a with flanges 12a and 14a. Similarly another section comprises the inside wall member 17b with flanges 13b and 15b, joined to the outside wall member 16b with flanges 12b and 14b. Another section comprises the inside wall member 17c with flanges 13c and 15c, joined to the outside wall member 16c with flanges 12c and 14c. The fourth section comprises the inside wall member 17d with flanges 13d and 15d, joined to the outside wall member 16d with flanges 12d and 14d. As shown, the outside member 16b is braced to the inside member 17b by the vertical Z shaped member 18b, in the manner described in connection with Figure 10. Similarly, outside member 16d is braced to the inside member 17d by the vertical Z shaped member 18d. It is obvious that I may provide more or less of these vertical bracing members as required, depending upon the particular application, and that these bracing members may be of various qualities in regard to thickness, rigidity, scorings, etc., to meet various specific conditions.

In forming a quadrilateral collapsible tube from the above named parts, flange 15a is affixed to sheet 17b adjacent to the score line forming one of the boundaries of flange 13b. Similarly, flange 15b is affixed to sheet 17c adjacent to the score line forming one of the boundaries of the flange 13c. Likewise flange 15c is affixed to sheet 17d; and flange 15d is affixed to sheet 17a. In this way the tube is completed. As seen in Figure 16, the tube so formed may be completely collapsed by bending the sheets along the score lines provided for that purpose; and when so collapsed, the tube will occupy a relatively small amount of space, as the various sheets which comprise the tube will be in substantially face to face relationship.

When the tube is expanded it may be inserted into a suitable casing, which will act to hold the tube in expanded position if the casing contains an element or elements which will prevent the casing from collapsing. With the standard shipping container the end flaps act to retain the proper angularity between the casing sides. The tubular construction, which I disclose, may therefore be used with a standard container to provide insulation to the container. When so used the container should be proportioned so that the outstanding flanges of the expanded insulating tube may fit snugly into the container, in the manner shown in Figure 15. By so fitting the casing and the insulating tube to each other, not only is the tube prevented from collapsing by being abutted by the casing, but, also additional air spaces are formed in this way. Thus, an air space 16b is provided between the panel 16b of the insulating tube and panel 81 of the casing. Similar air spaces are, of course, produced on

the other sides. Furthermore, the flange construction automatically provides for proper spacing of the tube within the casing.

The method just described of uniting four insulating sections to form an insulating tube may be generally applied to the various sections which I have described. In Figure 17 I have shown a quadrilateral structure formed from four simple sheets similar to the structure shown in Figure 1. As shown in Figure 17, both the flanges 4b and 5b of the panel 3b are secured, as by glue, to the adjacent panels 3c and 3a respectively. Similarly, both flanges 4d and 5d of panel 3d are secured, as by glue, to these adjacent panels, flange 4d being secured to panel 3a and flange 5d being secured to panel 3c. This completes the quadrilateral form.

When this structure is inserted within a casing of such dimensions that the insulating tube and the casing fit each other closely, "dead air" spaces are formed between each of the sides of the casing and each of the panels of the insulating tube. The four air spaces so formed are separated from each other by the flanges, which automatically provide proper spacing of the insulating form within the casing, in the same manner as is shown in Figure 15.

This is further shown in Figure 25 where a section of the form shown in Figure 17 is shown inserted in a section of a casing. Flanges 4a and 5a space the panel 3a the proper distance from the wall 80 of the casing. At the same time, flange 4a in abutting wall 81 of the casing prevents the panel 3a from movement toward wall 81. Similarly, flange 5a in contact with wall 79 of the casing prevents panel 3a from moving toward wall 79. Each of the four panels of the insulating form are similarly held in their proper position relative to the casing. As has been explained, the air space 101 formed between the wall 80 of the casing and panel 3a of the insulating form is separated from air space 100 by the flange 4d, and a portion of the panel 3a, and from the air space 102 by the flange 5b, and a portion of the panel 3a. Each of the four air spaces are thus independent of each other so far as any possible convection currents are concerned.

Figure 18 shows the form of Figure 17 in collapsed condition, it being necessary merely to fold the form on the score lines provided for that purpose. As with the form previously shown, it is necessary merely to push diagonal corners of the structure toward each other to collapse the shape.

In Figure 19 I have shown an insulating form quite similar to that shown in Figure 17. The simple shape of Figure 1 is used in forming the tube of Figure 19 as it was in forming the tube of Figure 17. However, in Figure 19, the parts are united with each other differently than that which has been shown in connection with Figure 17. Thus in Figure 19 one flange of each panel is secured to the adjacent panel, flange 4a being secured to panel 3b, flange 4b being secured to panel 3c, flange 4c being secured to panel 3d and flange 4d being secured to panel 3a. With this arrangement all the sections comprising the tube may be of the same size in producing a tube having a square section. With the construction shown in Figure 17, however, two opposed panels must be shorter than the other two, if the tube is to fit into a square section. In the collapsing of the section shown in Figure 19, two of the pan-

els will lie in perfect face to face contact with the other two panels, as is shown in Figure 20.

In Figure 23 I have shown a modified form of structure, in this case formed from the insulating units shown in Figure 4. Thus, one of such insulating units is represented by the two end panels 19a and 20a and the three diaphragms 103a, 104a and 105a. This makes up one of the sides of the quadrilateral form. The other sides are made up of similar parts. One has the end members 19b and 20b with diaphragms 103b, 104b and 105b; another has the end members 19c and 20c with diaphragms 103c, 104c and 105c; and a fourth has the end members 19d and 20d with the diaphragms 103d, 104d and 105d. As shown the four insulating wall members are united with each other through one of the end members on each wall, either being secured to the inner diaphragm on the adjacent wall member in any suitable manner. Thus as shown the end member 19a of one unit is secured to the diaphragm 103b of the adjacent wall member. The end member 19b at the opposite end of the diaphragm 103b is in turn secured to the diaphragm 103c of the next adjacent section; end member 19c is secured to diaphragm 103d; and end member 19d is secured to diaphragm 103a, thus completing the quadrilateral. As will be seen from the figure, when this structure is placed in the casing shown as having the sides 79, 80, 81 and 82, 79 and 82 being united with each other by the tape 106, there are formed three separate air spaces at each side of the casing, through which heat would have to travel in series from the outside as into the centre space 107. A very high degree of insulation is thus secured. It is readily apparent, also that I may easily increase the efficiency of the insulation by merely adding a further number of diaphragms on the insulating sections which make up the insulating form. That this insulating form is readily collapsible is shown in Figure 24 which shows the form of Figure 23 in a partially collapsed condition.

In Figures 21 and 22 I have shown a form of quadrilateral structure which may be obtained by uniting four portions of an insulating sheet similar to that shown in Figure 9. A similar form may, of course, be constructed using other of the simple shapes which I have described, as, for instance, the forms of Figures 7 and 8. Each of the rectangular sections are united with an adjacent section by means of one of the end walls of the section, in the same manner that the flanges of the previously described sections were utilized in uniting these sections to form a tubular structure. It will be noted that in Figure 21, both the inside wall and the outside wall of the tube are of the same material, as each of the sections is made from an integral blank of sheet material. This material may be of sufficient strength that it may be used directly as a shipping container. In this event the tube formed from the four united sections may be used directly as an insulated casing. The walls 28a, 28b, 28c and 28d in this event will be the outside of the casing, and the walls 27a, 27b, 27c and 27d will form the interior walls with the insulating air spaces 18a, 18b, 18c and 18d formed between the two series of walls. While this section may be made to collapse easily, as shown in Figure 22, it may nevertheless be used with a casing by providing proper end closure members which will act to retain the structure in its expanded tubular form. Such end closure members may be

plugs which may be inserted between the inner walls 27a, 27b, 27c and 27d, said plugs having flanges adapted to cover the open ends of the air spaces 18a, 18b, 18c and 18d. I show several forms of plug construction which may be thus used as closure members with the insulating section of Figure 21 to form a complete insulated casing in my copending application Serial No. 45,708, filed October 19, 1935, which is a continuation in part of my copending application Serial No. 739,962, filed August 15, 1931; and in my copending application entitled Collapsible insulating casing Serial No. 75,315 and filed coincidentally with the present application.

In order to more clearly show how the various forms of quadrilateral insulating structure which I have described may be used with an ordinary shipping container to provide an insulated casing, I have further illustrated my invention in Figures 26 to 30 inclusive, which figures I have shown an application of my invention to an insulated casing particularly adapted for shipment of a cylindrical can of ice-cream, such as is commonly used in the ice-cream trade.

It will be understood that a refrigerant, for instance, solid CO<sub>2</sub> may be enclosed with the shipment to compensate for such relatively small leakage of heat as will occur through the walls of the casing. It will, of course, be understood that where the casing is to be used for maintaining temperatures above atmospheric, a heat generating means may be enclosed.

In Figure 27, I show a developed form for a common type of casing into which I may insert my insulating filler in a manner as shown in Figure 26. The casing is a simple blank composed of the wall members 79, 80, 81 and 82 separated from each other by the score lines 91, 92 and 93. The wall members have the bottom flaps 87, 88, 89 and 90, and the top flaps 83, 84, 85 and 86. The top flaps are separated from the sides by score line 94, and the bottom flaps are separated from the sides by the score line 95. The blank is folded on line 92 and the free edges of sides 79 and 82 are united with each other by suitable means, as by a strip of gummed tape. This is a blank form in common use.

As shown in Figure 26 the casing is first set up in the ordinary manner by expanding the sides and then folding back the bottom flaps 87 and 88, followed by folding back the bottom flaps 89 and 90, which flaps substantially meet each other so as to be joined by the tape 110. A bottom tray shown in Figure 29 may then be inserted within the casing. The tray is formed from the integral blank comprising the main panel 111 and the flaps 112 separated from the main panel by the score lines 113. I prefer that the tray be formed from material of substantial strength to match that of corrugated board. Two trays as shown in Figure 29 are shown in Figure 26, one at the bottom of the casing with the flanges formed by the flaps 112 turned downwardly; and one at the top of the casing with the flanges formed by the flaps 112 turned upwardly. Both of these trays fit snugly within casing, as is shown for the top tray which is in section.

After the bottom tray has been placed within the casing, as has been explained, one of my insulating forms is inserted within the casing. As shown, for this particular application I prefer to use a number of relatively short sections, which extending for the height of the casing between the upper and lower trays, are positioned

from each other by the spacer members 114. The lower one of these insulating sections is shown as a quadrilateral structure formed from the insulating form shown in Figure 10. In constructing the section, flange 38a of the panel 36a is secured to the adjacent panel 36b, flange 38d of the panel 38a is preferably secured to the adjacent panel 36a, and so around the section, in the same manner as has been described in connection with the previously described quadrilateral structures. As shown the insulating section of which this quadrilateral structure is formed, comprises the inner members 36a to 36d which are preferably of a relatively strong material, such as corrugated board, and these panels serve as the inside of the completed shipping container. The two lines of webs 3 which form the air spaces may be of lighter material and may be braced at suitable intervals by the Z strips 39 and 40 in the manner as has been previously described in connection with Figure 10.

After the lower insulating structure, which fits snugly within the walls 79, 80, 81 and 82, has been set in place, it has superimposed upon it the spacing member 114. Member 114, which is shown in detail in Figure 30, is a sheet of material, for instance, corrugated board, of such dimensions as to fit closely within the four walls 79, 80, 81 and 82. The centre of the member 114 is provided with a hole 115 of sufficient size to receive the ice-cream can which is to be shipped in the container. This hole will, of course, be entirely within the space bounded by the walls 36a, 36b, 36c and 36d. The solid portion of the sheet will therefore completely cover the open end of the insulating section, so as to effectively seal the air spaces therein, and in this way limit such convection currents as might be set up within the air spaces. As has previously been pointed out, the bracing Z strips spanning the air spaces also serve to limit convection currents.

After the lower spacing sheet 114 has been set in place, a second insulating form is placed within the casing. As shown this section is provided with three air spaces rather than two as shown for the lower insulating section. The reason for this preference will be explained later. However, where desired the same type of insulating section may be used throughout, and such insulating forms may be any of the modifications which fall within the scope of my invention. In Figure 28 I show the details of the second insulating section shown in Figure 26. As will be noted it is of the same construction as the lower insulating section, except that it is provided with three diaphragms instead of with two, as is shown in the lower section. Thus each sheet that comprises the section consists of a channel shaped member as the web 36f with its two flanges 37f and 38f. This channel is preferably of corrugated board. Attached to this member are the three channel shaped diaphragms having the webs 115 and flanges 116 by which the diaphragms are secured to the flanges 37f and 38f. The Z shaped reinforcing members 117 brace the diaphragm as required. The complete section is obtained by arranging four similar sections to each other in the manner described for producing the lower section. That is, a flange of one unit, such as flange 38f, is preferably secured to the web of an adjacent sheet, such as 36g; and, so on around the section. This section is inserted within the four walls 79—82 which it fits closely as shown in the figure.

A second spacing member 114 is next inserted within the casing. This member covers the top ends of the air spaces formed in the insulating section just below. The air spaces of this section are thus sealed at each end by spacing members 114 which limits the convection currents which may be set up in this section, just as the air spaces on the bottom insulating section were sealed off between the lower spacing member and the bottom tray as has been described.

The top insulating section which is shown as exactly similar to the bottom insulating section is then inserted. This is followed by the top tray 111. Thus the top construction is similar to the bottom construction, so that if the casing were inverted, so far as the casing and insulating lining are concerned, there would be no variation between the top and the bottom. The top flaps 83 and 85 of the casing are then turned down to lie in a plane perpendicular to the walls 79 to 82. Flaps 84 and 86 are then turned down to lie over the flaps 83 and 85. The casing may be sealed with the tape 118.

It will be seen in the illustration that the top flaps 83—86 form a double layer of material over the top of the package. Moreover, this double layer rests upon the edges of the upturned flanges 112 of the tray 111, and in conjunction with this tray forms a protecting air space 119 over the top of the container. The construction at the bottom of the container is similar to that at the top, as has been explained. A similar protective air space is therefore formed as a protection for the bottom end. Full flaps may be used, if desired.

When used for shipping ice-cream in a can or other container, the can is passed through the holes 115 in the spacers 114. These holes are so proportioned that they will prevent side movements of the can. The bottom of the can rests upon the lower tray 111, and the can and the casing are so proportioned relative to each other that when the upper tray 111 is put in place, its centre will rest against the lid of the can. Endwise movement of the can will thus be guarded against.

The purpose of the greater insulation which I show around the centre of the container, as compared to the insulation at the two ends, will now be explained. It is a common practice to ship ice-cream with solid CO<sub>2</sub> in the package, and this refrigerant is usually placed within the container at both the top and bottom. With a uniform insulation the amount of heat entering the compartment does not vary greatly lengthwise of the casing; but the refrigerating medium is concentrated at the two ends. Thus, the ice-cream located centrally of the container from end to end of the container attains a higher temperature than the ice-cream at the two ends of the can. By providing a more effective insulation on a central belt around the container than at the two ends, a more uniform condition of temperature in the ice-cream is secured. In order to further increase the insulating efficiency of the central member, and hence to further the uniformity of temperature in the ice-cream, certain of the sheets which comprise the central insulating member, such as the diaphragms 115 may be covered with polished metallic foil, or other heat reflection means as steel wool may be inserted, and the end portions may have absorption surfaces. Also the horizontal partitions may serve for carrying CO<sub>2</sub> at the middle of the container.

In describing the various insulating sections formed by uniting my insulating sheets at their

corners, I have spoken of the section as a quadrilateral form. This, of course, is by way of example, and due to the fact that the usual container with which my section will be used is of quadrilateral section. It will be understood, however, that where a triangular, pentangular, hexangular, circular, etc. casing is to be insulated, it is obvious that corresponding insulating forms may be used.

In Figure 31, I have shown how my collapsible insulating unit may be used as an insulating filler for an insulating casing, such as I show in my aforementioned copending application. In this figure I show a double walled casing having outer walls 120, 121, 122 and 123, and inner walls 125, 126, 127 and 128 spaced from the outer walls by the flanges 130 and 131. As may be seen an insulating air space is formed between an inner wall, a corresponding outer wall and the adjacent flanges. The efficiency of this air space may be increased by dividing it into narrower air spaces. This may be simply done by inserting one of my insulating units of proper dimension in this air space. As illustrated in Figure 31, I show insulating units similar to that shown in Figure 10 inserted within the air spaces between the inner and outer walls of the container. It will be noted that in this illustration the insulating sheet is composed of comparatively thin material, and it may be formed of such inexpensive sheets as thin chip board, due to the fact that the casing itself has sufficient strength to withstand the mechanical stresses, and the insulating unit has merely to supply additional resistance to the passage of heat.

As shown in the Figure 31, each of the insulating units in each of the air spaces consists of the channel shaped member having the web 36 and flanges 37 and 38, to which are secured the flanges 4 and 5 of the webs 3. The braces 39 and 40 brace the various webs to each other.

It will be further understood that other forms of my collapsible insulating sheet may be used in the manner just described, depending upon the

particular application. Also a suitably shaped portion of the various modifications of my collapsible insulating sheet may be applied in the space 134 between the top cover 133 and the inner closure 132.

While I have described my invention for use in connection with shipping containers and similar applications, it may be used in its several modifications for other purposes, as, for instance, an insulating filler for building walls, as between the joists of frame constructed building.

Throughout the foregoing specifications, a number of various modifications of my invention have been described. The particular forms shown have been given by way of illustration only, as it will be apparent that many other modifications may be made without departing from the scope and spirit of my invention as expressed in the appended claims. Now having explained my invention in a manner that it may be readily understood by one skilled in the art, I claim:

1. A container comprising walls, collapsible heat insulation units of nonmetallic sheet material comprising opposed parallel wall portions, and complementary opposed connected spacer portions which when set up for use surround an insulating air space, each of the opposed spacer portions extending beyond the line of connection with an adjacent wall portion, the free edges of the spacer extensions abutting on interior wall surface, said units coacting with said container walls to form parallel-partitioned insulating air spaces at each interior wall surface and co-acting with each other and with said container walls to maintain a predetermined spacing.

2. A collapsible insulation unit for a body portion comprising a plurality of group members, the members of each group having parallel faces hingedly secured to each other to form a rectangle and collapsible about the hinges into a substantially flat unit, and projections extending beyond each group of hinged edges for engaging the corresponding wall of said body portion.

PHILIP ZALKIND.