

July 7, 1964

R. HILT

3,139,703

SHEET METAL COVER FOR EXISTING WINDOW FRAME

Filed April 26, 1961

3 Sheets-Sheet 1

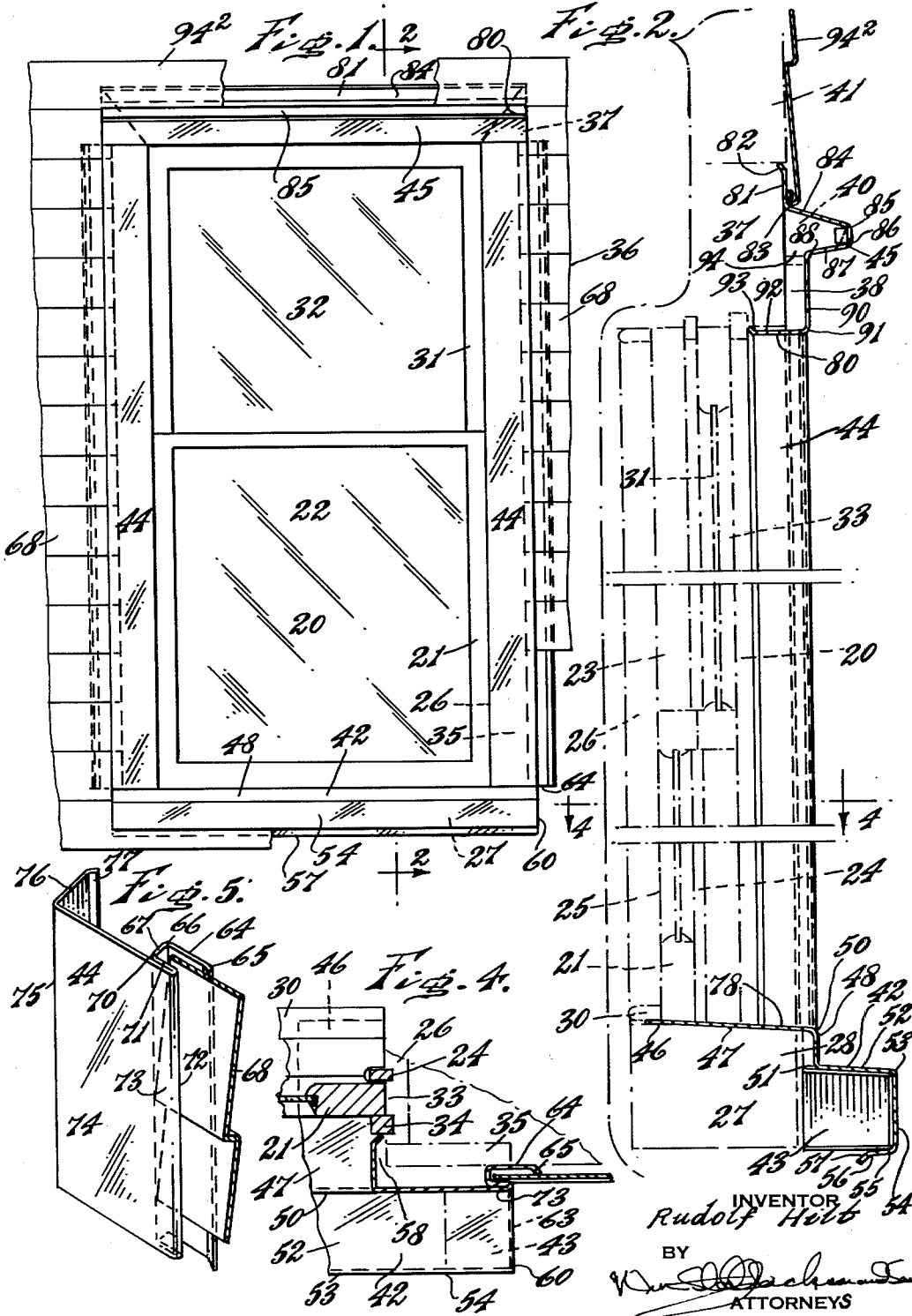

July 7, 1964

R. HILT

3,139,703

SHEET METAL COVER FOR EXISTING WINDOW FRAME

Filed April 26, 1961

3 Sheets-Sheet 2

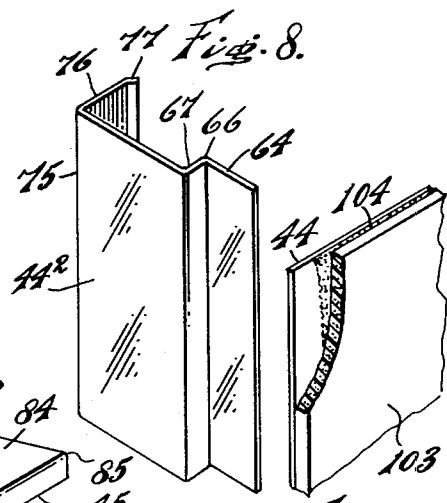
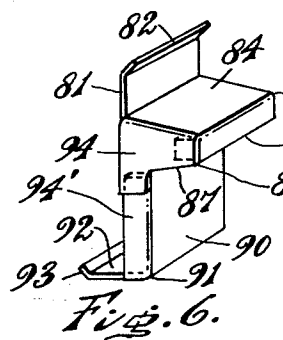
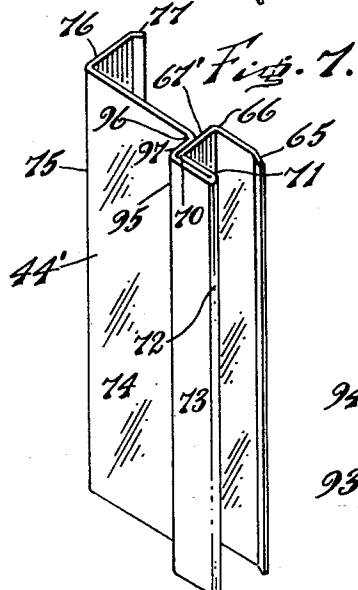
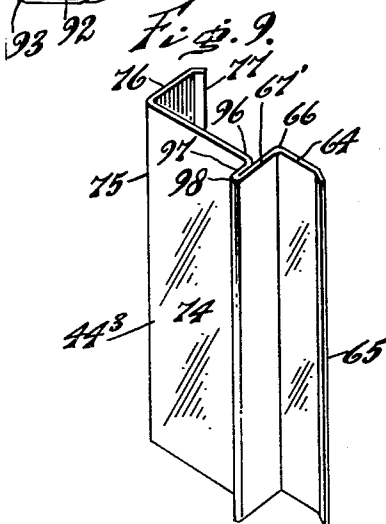
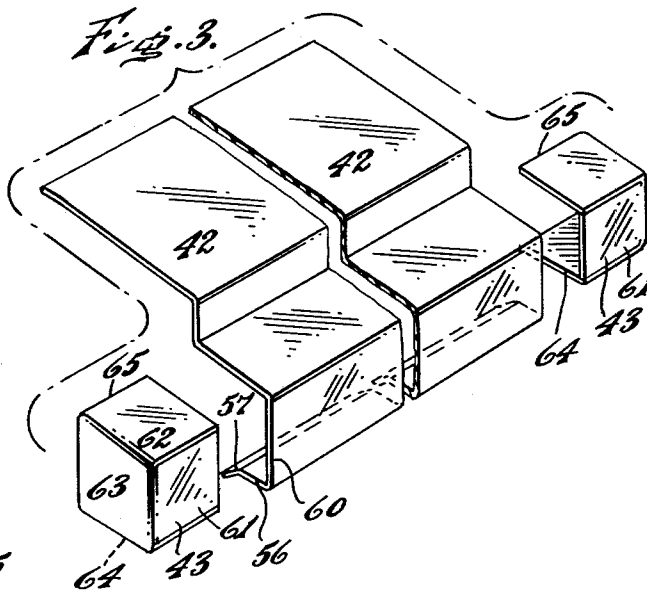
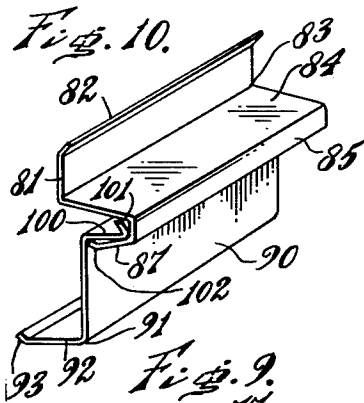

July 7, 1964

R. HILT

3,139,703

SHEET METAL COVER FOR EXISTING WINDOW FRAME

Filed April 26, 1961

3 Sheets-Sheet 3

Fig. 12.

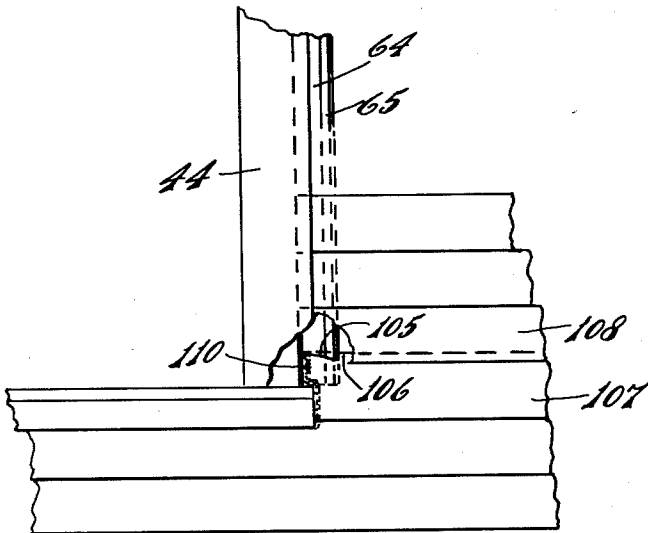

Fig. 7a.

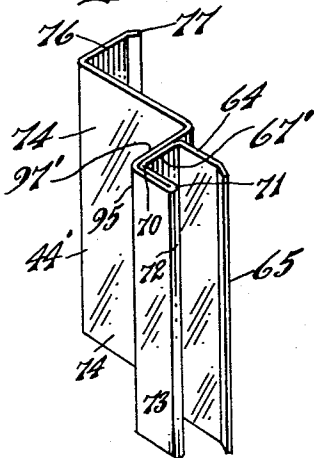
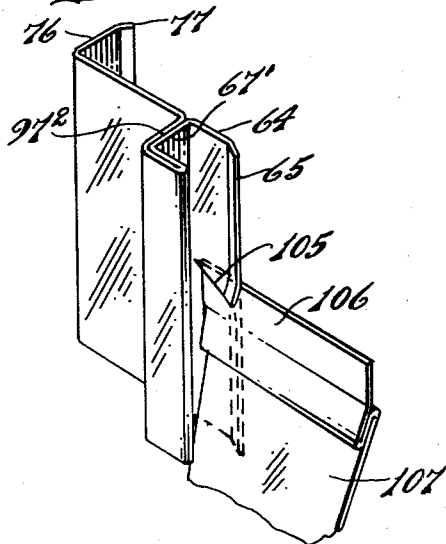

Fig. 7b.



INVENTOR

Rudolf Hilt

BY

[Signature]
ATTORNEYS

1

3,139,703

SHEET METAL COVER FOR EXISTING WINDOW FRAME

Rudolf Hilt, 202 Lehigh St., Hokendauqua, Pa.

Filed Apr. 26, 1961, Ser. No. 105,716

1 Claim. (Cl. 50-118)

The present invention relates to covers for windows and doors of existing buildings suitably frame buildings, to be used in connection with the installation of metal or other siding. The invention can also be used on new buildings.

A purpose of the invention is to provide a cover for windows and doors of old houses, which will protect against deterioration by the weather and improve the appearance.

A further purpose is to provide a cover for windows and doors of old houses which will fit in with metal siding and protect against leakage between the metal siding and the window or door.

A further purpose is to provide a cover for the sill of a window which will extend under the stool, and which will cover the subsill and the sill.

A further purpose is to provide a weather edge on the cover under the sill.

A further purpose is to provide a cover for the trim on a window or door which will extend along the inside of the trim, over the front of the trim, along the outer edge of the trim and under metal or other siding.

A further purpose is to provide a cover for the trim on a window or door which will cover and seal the ends of metal or other siding.

A further purpose is to provide a cover for the trim on a window or door which will have an outward protrusion at the edge of the trim which is remote from the center of the window or door, preferably coupled also with an overhang over the metal or other siding.

A further purpose is to provide a cover for the header of a window or door which will extend under metal or other siding, will form a drip cap, and will extend over the front and under the header, desirably having weather edges at the top and bottom of the cover.

A further purpose is to divert outwardly water which is flowing down the channel at the outside of the trim cover so that it will not enter the space between the new metal siding and the old wall, preferably by cutting the portion of the channel which is parallel to the old wall near the bottom of the trim cover and extending the upper portion of one panel of siding through the cut opening to a position behind the weather edge of the channel.

In the drawings I have chosen to illustrate a few only of the numerous embodiments in which the invention may appear, selecting the forms shown from the standpoints of convenience in illustration, satisfactory operation and clear demonstration of the principles involved.

FIGURE 1 is a front elevation of a cover for a window according to the invention, partially broken away to illustrate the structure more clearly.

FIGURE 2 is a partially broken enlarged vertical section of FIGURE 1 on the line 2-2.

FIGURE 3 is a fragmentary perspective showing the cover for the sill and showing the end caps as embodied in FIGURES 1 and 2.

FIGURE 4 is a fragmentary horizontal section of FIGURE 2 on the line 4-4 showing partly the cover for the outer trim.

FIGURE 5 is a fragmentary perspective showing the cover for the outer trim of FIGURES 1 to 4 along with the metal or other siding.

FIGURE 6 is a fragmentary perspective showing the

2

bending of the ends of the cover for the header in the form of FIGURES 1 to 5.

FIGURE 7 is a perspective view somewhat similar to FIGURE 5 showing a modified form of cover for the trim and omitting the siding.

FIGURES 7a and 7b are views similar to FIGURE 7 showing modifications. FIGURE 7b also illustrates the cutting of the weather edge of the trim cover to allow the metal siding to extend behind the trim cover.

FIGURES 8 and 9 are perspectives similar to FIGURE 7 showing further modifications in the cover for the trim.

FIGURE 10 is a fragmentary perspective showing a modification in the cover for the header according to the invention.

FIGURE 11 is a fragmentary section of a piece of window or door cover according to the invention provided with an insulating lining.

FIGURE 12 is a fragmentary illustration partly broken away showing the siding extending behind the weather edge of the trim cover near the bottom of the trim cover and showing caulking from the top of the last piece of siding to the bottom of the sill cover.

Describing in illustration but not in limitation and referring to the drawings:

Extensive work is being done in applying metal siding to cover the walls of buildings, especially frame and stucco buildings. Difficulty has been encountered, however, because of inability to make tight joints at the windows and doors and because of the fact that the windows and doors were not themselves adequately protected. Thus where aluminum or stainless steel siding has been applied, while the walls have been protected, windows and doors have continued to deteriorate, even permitting leakage, and have not measured up to the standard of appearance of the metal siding.

The present invention is concerned with providing metallic covers for windows or doors of pre-existing buildings, especially frame and stucco buildings, which will greatly increase the resistance of the windows and doors against deterioration, will make effective weather seals with the metal siding, and will enhance the appearance of the windows and doors.

Referring first to the embodiment of the invention shown in FIGURES 1 to 6, the cover of the invention is shown applied to a window, but it will be evident that, except for omission of the cover for the sill, the same technique can be used in applying the invention to a door.

The window as shown has a window opening 20 filled by a lower sash 21 having glass 22 and riding in a guideway 23 between an outer guide strip 24 and an inner guide strip 25 in a frame 26 as well known. The window has a sill 27 at the bottom which extends out beyond the sash and above the sill and set in from it at the front is a subsill 28 on top of which at the inside is a stool 30, all as well known in the art.

There is also an upper sash 31 having glass 32 and riding in a guideway 33 between the outer guide strip 24 of the inner guideway and an outer guide strip 34 of the outer guideway 33 of the frame 26. The frame at the sides is provided with outside trim 35.

The trim in an old building is placed on top of pre-existing siding (stucco or the like) 36 of the building as well known.

What is being said about the trim would apply also to a door.

At the top of the window there is a header 37 which has a front portion 38 which would normally have above it a drip cap 40. This construction will be generally similar in windows and doors. The pre-existing siding or stucco or the like 41 of the building blends into and

suitably extends under a portion of the header 37 as well known.

The sheet metal cover of the invention comprises a sill cover 42, end caps 43, trim covers 44 at each side of the window or door, and a header cover 45 at the top.

The first operation in installing the covers of the invention is to remove the previous drip cap from the header and desirably slightly raise or loosen the stool 30.

The sill cover 42 consists of a generally horizontal portion 46 which is adapted to extend in under the stool 30, a generally horizontal but slightly outwardly sloping portion 47 which rests on and lies against the subsill 23, then a downwardly extending portion 48 connected at 50 by a bend slightly greater than a right angle with the portion 47, the portion 48 extending over the front of the subsill. At the bottom of the portion 48 there is a bend at 51 slightly more than a right angle to connect with a generally horizontal slightly outwardly sloping portion 52 over the top of the sill which connects by a bend at 53 slightly more than a right angle with a vertically downwardly extending portion 54 over the front of the sill which is then bent approximately at right angles at 55 to form an extension 56 under the sill and terminating at the inside of a weather edge 57 which is bent downwardly at an angle of suitably 45 degrees to the previous line of extension.

The sill cover is notched at 58 at the ends to extend through the space between the outside trim 35 and the frame 33 at the two sides, and the portions 48, 52, 54 and 55 are cut off flush with the ends of the sill at 60 as best seen in FIGURE 4. This permits proper fitting of the sill cover as shown in FIGURES 1, 2 and 4.

Sill end caps 43 have a front portion 61, a top portion 62, an end portion 63 and a bottom portion 64. The rear ends of the top portion 62, the end portion 63 and the bottom portion 64 are cut off along the line 65 as best seen in FIGURE 3 so that the end caps can fit firmly against the sill without protruding unnecessarily beyond the sill, and then the end caps are slipped in under the sill cover as best seen in FIGURES 2 and 4 so that the end portion 63 rests against the end of the sill.

The sill cover and the sill end caps are now ready for nailing, which will conveniently be accomplished under the sill, along the top of the sill and along the top of the subsill as required to properly anchor the sill cover and sill end caps. Due attention should be paid to the metal couple formed between the metal of the cover and end caps and the metal of the nails, both in this case and in the case of the other components to be referred to. Thus if the sill cover and end caps are of aluminum alloy, aluminum alloy nails should be used, and if the sill cover and end caps are of stainless steel, stainless steel nails should be used.

Next the side trim covers 44 are cut so as to fit the header at the top and the sill cover at the bottom. In the preferred embodiment as shown in FIGURE 5, the trim cover comprises a portion 64 which fits against the outside of the siding or other wall of the house substantially flush therewith and which terminates at the edge of the strip remote from the center of the window or door in a weather edge 65 which is suitably bent out at an angle of about 30 degrees from the plane of the wall of the building. The portion 64 is then bent at a right angle at 66 to form an integral portion 67 which extends out from the wall of the building for a distance adequate to accommodate the overall thickness of metal or other siding 68 which is to abut against it. In the preferred embodiment the trim cover is then bent at 70 substantially in a right angle to form an overhang portion 71 which will cover the end of the siding and protect it from the weather and prevent the need for caulking by providing a weather-tight drainage channel.

The trim cover is then bent back on itself at 72 to form a portion 73 which lies directly against the outside of the

portion 71 and is parallel to the wall of the building. Then in the preferred embodiment of FIGURE 5 the trim cover has a relatively broad portion 74 which is flush with the portion 73 and in continuation of it and terminates at the edge of the trim toward the center of the window or door in a right angle 75, an inner portion 76 which lies against the edge of the trim toward the center of the window, and then a weather edge 77 which in this case is bent in toward the trim of the building at an angle of approximately 150 degrees to the portion 76.

In fitting the trim cover to the trim of the window or door, the bottom of the portion 76 will be suitably cut at a slight angle at 78 as shown in FIGURE 2 to fit against the top of the portion 47 of the sill cover. The top of the trim cover can suitably be mitered at 80 in FIGURES 1 and 2. Nailing of the trim cover will desirably be accomplished along the portion 64 which suitably extends outwardly beyond the reverse bend 72, and along the inner portion 76, using nails of the proper metal.

After the insertion of the trim covers, the header cover 45 is suitably cut at the ends to fit the ends of the header and to fit the trim cover. The header cover suitably comprises a portion 81 near the top which is flush with the old siding or the wall, and terminates in a weather edge 82 suitably bent in toward the building at an angle of 150 degrees to the portion 81.

There is then an outward bend at 83 on an angle slightly greater than a right angle to form the top portion 84 of drip cap 85. At the outer end, the drip cap 85 is reversely bent at 86 forming a bottom portion 87 of the drip cap which suitably extends in toward the wall of the building less far than the top portion 84. There is then an angle 88 somewhat greater than a right angle which connects with a front portion 90 of the header cover at the bottom of which there is a right angle bend 91 which connects with an under portion 92 of the header cover terminating underneath in a weather edge 93 suitably at about 150 degrees to the portion 92.

At the ends the portions 92 and 93 will be notched out to fit under the header, and at the end of the header portions 82, 81 and 87 will be cut off flush with the ends of the header but portion 84 and part of the front of the drip cap will be bent down as shown at 94 in FIGURE 6, and portion 90 will be cut longer and bent back at the end at 94'.

The nailing of the header cover is suitably accomplished by a row of nails along the portion 81 and a row of nails through the portion 92 beneath the header.

The nails through the portion 81 are covered by the siding 94² which is later applied.

In some cases the total accumulated width of the siding is greater than that shown in FIGURES 1 to 6, and for that purpose an alternate form of trim cover 44' is shown in FIGURE 7 in which the portion 73 is joined to the portion 74 by right angle bends 95 and 96 and an intermediate portion 97, while the portion 67 is made wider to form a portion 67' capable of receiving metal siding of greater width. Except for the difference in dimensions the form of FIGURE 7 is similar to that of FIGURE 5.

In some cases as shown in FIGURES 7a and 7b the relative dimensions of the portions 97 and 67' will be changed, in order to adapt the trim cover to a different relationship of the surface of the old wall to the surface of the trim. Thus where the surface of the old wall protrudes beyond the trim of the old window, the form of FIGURE 7a will be used, where 67' has a smaller dimension than 97'. On the other hand where the surface of the old wall and the surface of the trim are flush, the form of FIGURE 7b will be used, where 67' and 97² are of approximately equal dimensions.

In some cases it is preferred to make the trim cover 44 by eliminating the weather edge 65 and abut the metal siding directly against portion 67 of the trim cover as

shown in FIGURE 8, eliminating the overhanging portions 71 and 73.

In some cases also where the siding is deeper or wider in distance away from the wall of the house, the portion 67 is extended to the portion 67' of FIGURE 9 but a reverse bend is provided at 98 to form portion 97 which connects to portion 74 by a right angle bend at 96. This trim cover 44³ of FIGURE 9 will be caulked to the abutting siding.

In some cases also the header cover is conveniently formed in two parts. A lower portion covers the front of the header and terminates in an outwardly projecting portion 100 terminating at the outer end in a weather edge 101 which is reversely bent with respect to the portion 100. This is covered by a separate drip cap cover which terminates in portion 87, having a weather edge 102 bent at an angle of the order of 150 degrees to the line of the portion 87.

This combination can be mounted by nailing at 81 and nailing at 92 and otherwise functions similarly to that of FIGURES 1 to 6.

The window and door covers may of course be natural bright or mat aluminum alloy or stainless steel. In the case of aluminum alloy it can be colored by anodizing.

In one embodiment of the invention, as shown in FIGURE 11, the metal is lined with a layer of plastic insulation 103 suitably bonded to it by adhesive 104. The insulation may for example be polystyrene foam insulation if desired.

There is a tendency for water to run down along the edges 64 and 65 of the trim cover, and unless precautions are taken when it encounters the end of the sill cover, the water may tend to run in behind the metal siding and between the metal siding and the old wall. To prevent this

I show in FIGURES 7b and 12 cutting at 105 of the weather edge 65 and the portion 64 which lies against the old wall, so that the upper part 106 of the next piece 107 of metal siding can extend slightly up behind the weather edge 65 and the portion 64, while the next adjoining upper piece of siding 108 can lap over the cut 105. Caulking is then introduced at 110 between the end of the lower piece of siding and the adjoining portion of the trim cover and of the sill cover, so as to prevent the possibility that water running down can get into the space between the siding and the old wall.

It will of course be evident that the door and window covers can be available in any desired color or combination of colors which can be applied as a preliminary treatment or else can be applied on the job. It is preferred however to apply the coloring at the time of manufacture.

In view of my invention and disclosure, variations and modifications to meet individual whim or particular need will doubtless become evident to others skilled in the art, to obtain all or part of the benefits of my invention without copying the structure shown, and I, therefore, claim all such insofar as they fall within the reasonable spirit and scope of my claim.

Having thus described my invention what I claim as new and desire to secure by Letters Patent is:

In a sheet metal cover for the trim at the side of a window or door, a continuous integral sheet metal shape having a portion adapted to lie against the siding of the building and under the metal siding to be applied, a portion extending outwardly from the building transversely from the portion adapted to lie under the metal siding which portion is adapted to extend along the end of the metal siding, a portion bent transversely to the portion just mentioned adapted to extend across the front of the trim and a portion bent transversely to the portion adapted to extend across the front of the trim for covering the inner edge of the trim, in combination with siding extending over the portion adapted to lie against the old siding of the building, there being a cut extending from the edge of the portion adapted to lie against the siding of the building toward the trim, said metal siding extending through said cut with its upper portion behind the portion of said trim cover adapted to lie against the siding of the building and its lower portion in front of the portion of the trim cover adapted to lie against the siding of the building.

References Cited in the file of this patent

UNITED STATES PATENTS

35	405,232	Symonds	June 11, 1889
	855,696	Corbett	June 4, 1907
	911,455	Sjorbring	Feb. 2, 1909
	918,213	Specht	Apr. 13, 1909
	1,258,044	Plym	Mar. 5, 1918
40	1,520,826	Knapp	Dec. 30, 1924
	1,521,938	Gartenberg	Jan. 6, 1925
	1,644,028	Petersen	June 2, 1927
	1,843,056	Welty	Jan. 26, 1932
	1,921,040	Reynolds	Aug. 8, 1933
45	1,950,519	Ripley	Mar. 13, 1934
	1,952,957	Wieting	Mar. 27, 1934
	2,635,720	Kolkey et al.	Apr. 21, 1953
	2,685,712	Tennison	Aug. 10, 1954
	2,687,194	Kelly	Aug. 24, 1954
	2,851,742	Johnston	Sept. 16, 1958