

Aug. 15, 1961

E. L. SCHLAGE

2,996,326

FACEPLATE FOR BEVELED AND RABBETED DOORS

Filed April 20, 1959

2 Sheets-Sheet 1

FIG 1

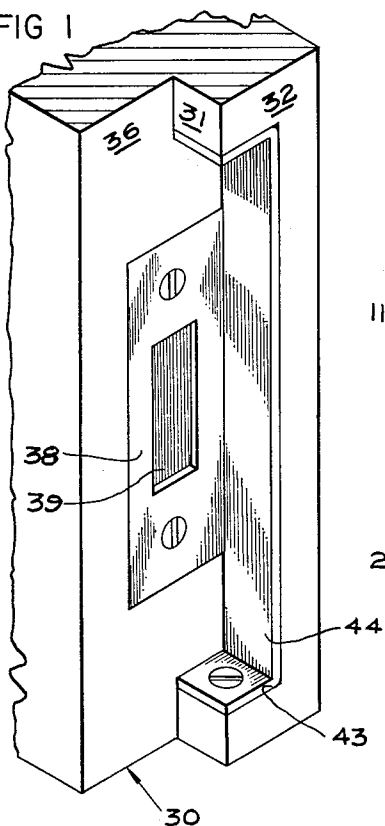

FIG 2

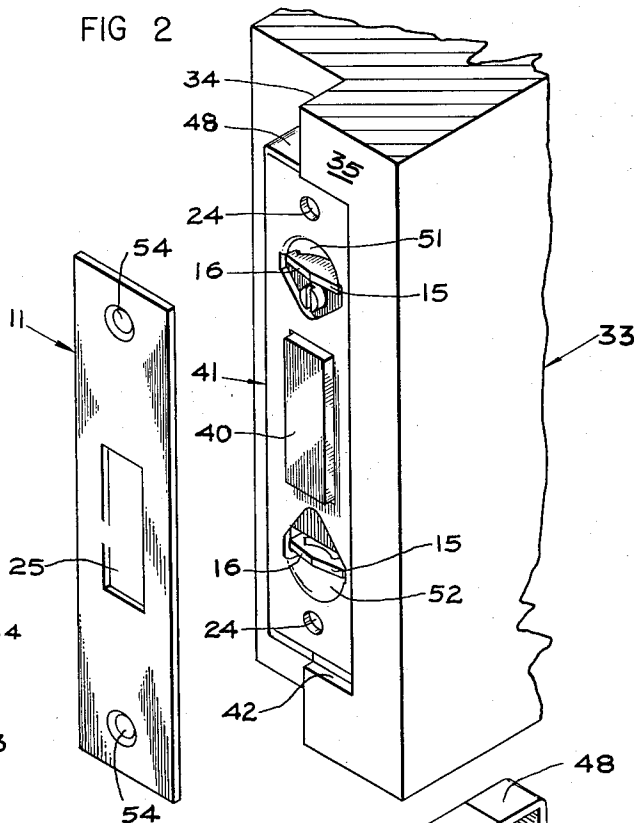

FIG 3

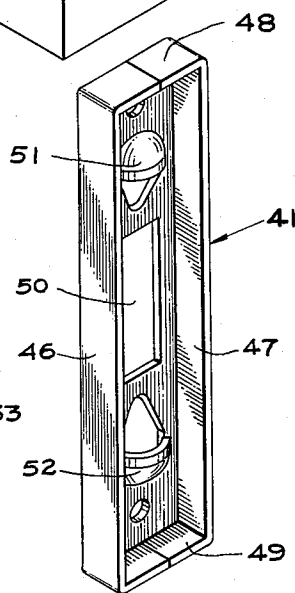

FIG 5

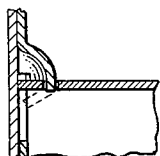

FIG 6

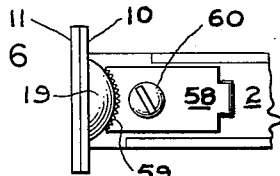

FIG 7

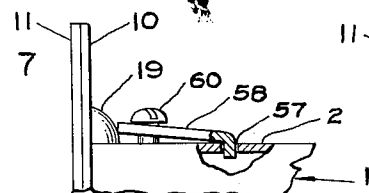
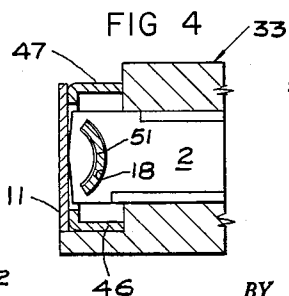

FIG 4



INVENTOR.
ERNEST L. SCHLAGE

BY
Boyken, Mohler + Wood

Aug. 15, 1961

E. L. SCHLAGE

2,996,326

FACEPLATE FOR BEVELED AND RABBETED DOORS

Filed April 20, 1959

2 Sheets-Sheet 2

FIG 8

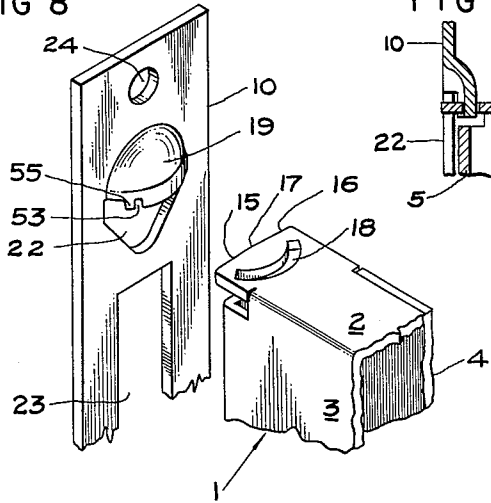

FIG 9

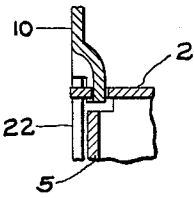

FIG 10

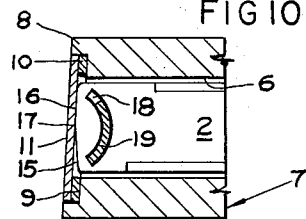

FIG 11

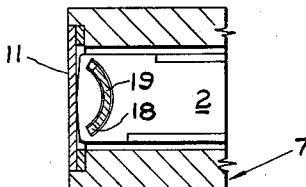

FIG 12

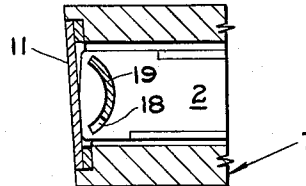

FIG 14

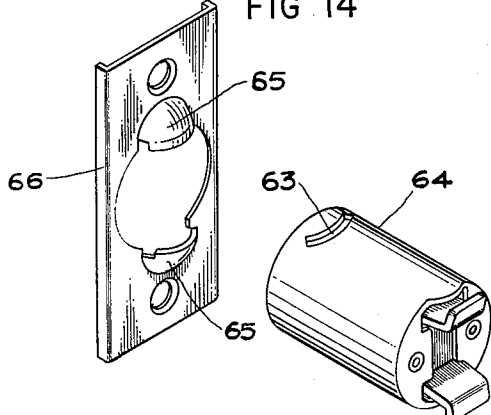

FIG 13

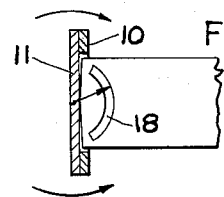
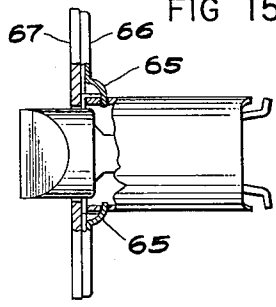

FIG 15



INVENTOR.
ERNEST L. SCHLAGE

BY
Boyer, Mohler & Wood.

1

2,996,326

FACEPLATE FOR BEVELED AND RABBETED DOORS

Ernest L. Schlage, Burlingame, Calif., assignor to Schlage Lock Company, a corporation
 Filed Apr. 20, 1959, Ser. No. 807,482
 3 Claims. (Cl. 292—337)

This invention relates to a faceplate for a latchset or lockset and is particularly directed to a faceplate that is tiltable relative to the latch housing or lock housing to which it is connected, so that it may be employed on beveled doors if desired.

Ordinarily the edge of the door through which a latch or bolt projects is perpendicular to the opposite faces of the door, in which case the faceplate for the latch housing is at right angles to the line of action of the latch bolt. However, in the case of relatively thick doors it is necessary, in order to obtain a reasonably snug fit between the door and doorjamb, to bevel the door so that the edge through which the bolt projects is angularly disposed relative to the bolt. In such a case it is necessary to secure the faceplate to the bolt housing so that it is tiltable relative thereto to permit installation of the faceplate at the proper angular relationship relative to the bolt.

Heretofore the use of such a tiltable faceplate has had the disadvantage of requiring that the hole in the faceplate be much wider than the width of the bolt to permit the bolt to project therethrough regardless of the angular relationship of the faceplate and housing. This results in an unsightly space between the bolt and one edge of the latch bolt hole in the faceplate; or, if the faceplate is used on an unbeveled door, a relatively large clearance exists on both sides of the bolt.

The main object of the present invention is therefore the provision of a tiltable faceplate for a door which tilts about an axis substantially coincident with the faceplate so that the clearance between the bolt and the bolt opening in the faceplate may be reduced to a minimum.

Another object of the invention is the provision of a tiltable faceplate structure that lends itself to use with a beveled door and, at the same time, may be used on an unbeveled door and also on a rabbeted door.

Still another object of the invention is the provision of a tiltable faceplate in which the faceplate is firmly secured to the housing so that said faceplate adequately supports said housing against shifting.

Other objects and advantages will be seen in the following specification and in the drawings:

FIG. 1 is a fragmentary perspective of a rabbeted door-jamb;

FIG. 2 is a fragmentary exploded view of rabbeted door adapted to cooperate with the jamb of FIG. 1 and showing the backplate of the lock housing on the door and with the faceplate spaced from the backplate;

FIG. 3 is a perspective of the backplate taken from the side opposite that shown in FIG. 2;

FIG. 4 is a horizontal section through the door of FIG. 2 showing the backplate and faceplate in section and the top of the housing in plan;

FIG. 5 is a fragmentary longitudinal section through the assembled faceplate, backplate and housing showing the manner in which the backplate is connected to the housing;

FIG. 6 is a fragmentary top plan view of the housing showing one method of securing the backplate thereto;

FIG. 7 is a side elevation, partly in section, of the assembly of FIG. 6;

FIG. 8 is a fragmentary exploded perspective of a backplate and housing used for beveled doors;

FIG. 9 is a fragmentary vertical section through the structure of FIG. 8 when assembled;

2

FIG. 10 is a horizontal section through a beveled door showing the faceplate tilted in one direction relative to the housing;

FIG. 11 is a horizontal section through a door beveled in the opposite direction from that of FIG. 10 showing the associated faceplate;

FIG. 12 is a view similar to FIG. 11 but showing the faceplate tilted to a maximum amount to accommodate a door having an extreme bevel;

FIG. 13 is a semischematic section through the faceplate showing the radius of the arc to which the slot in the housing is formed;

FIG. 14 is an exploded perspective of a cylindrical latch bolt housing and associated backplate made in accordance with the invention;

FIG. 15 is an elevation of the assembled backplate and faceplate and housing of FIG. 15 but broken away to show their interengagement.

Reference is made first to FIG. 8 wherein the upper portions of a backplate and associated mortise lock housing are shown, and to FIGS. 9, 10 showing the connection between the housing and plate.

The generally rectangular housing generally designated 1 is provided with a top 2, a pair of opposed sides 3, 4, and a front side 5 (FIG. 9). As seen in FIG. 10 the housing 1 is inserted in a complementarily formed recess 6 in a door 7 and the adjacent edge 8 of door 7 is provided with a rectangular mortise 9 which is adapted to receive therein a backplate 10 and a faceplate 11.

As will be better understood later on, the backplate 10 is directly connected to the housing 1 and the faceplate 11 is then secured over the backplate and to the door to give a finished appearance. It is apparent that the backplate could be omitted and the faceplate connected directly to the housing, although such a procedure is not desired and is followed only in inexpensive locks. However, in this disclosure, the term "faceplate" will be understood to include the assembly of faceplate and backplate and will also be understood to include only a backplate since, as a practical matter, the backplate and faceplate may be considered as a unit. Therefore in the claims the term "faceplate" should be read as also meaning a backplate of the type disclosed herein.

In the following description of the upper connection between faceplate and housing it will be understood that a similar connection exists at the lower end of the faceplate. The front edge of top 2 of the housing 1 is beveled from the center toward the sides 3, 4 to provide a pair of slightly diverging edges 15, 16 (FIG. 10) the angle of which corresponds to the maximum bevel that should be encountered in a door. The central juncture 17 therefor becomes a pivot about which the faceplate 11 may tilt (FIGS. 10-12). The structure disclosed herein will be understood to be applicable to both left and right hand doors.

Inwardly from pivot point 17 there is provided an arcuate slot 18 which is formed with a radius of curvature having a center on the central longitudinal extending axis of the faceplate 11 (FIG. 13). Cooperating with slot 18 is a dome-like lug 19 struck from backplate 10 and received in slot 18. Lug 19 is formed to the same radius as slot 18 but, in the embodiment of FIGS. 8-13, the extent of said lug longitudinally of slot 18 is less than the length of the slot so that the backplate may be tilted as illustrated in FIGS. 10-12 while holding faceplate 11 in engagement with pivot point 17. Since the above described structure is the same as that at the bottom of the housing it is necessary to bend the top 2 (or bottom) inwardly of the housing as indicated by dotted lines in FIG. 5 to permit the assembly. It will be noted that an opening 22 is provided in backplate 10 under lug 19 to permit one to insert a screwdriver or like

tool therethrough for the purpose of bending back the end of the top 2 to the horizontal position of FIG. 9.

The backplate 10 is provided with an opening 23 for receiving the bolt therethrough, and screw holes 24 are also provided for receiving the screws (not shown) which hold the faceplate 11 to the door.

Heretofore it has been customary to provide the backplate with a lug which entered an oversized hole in the bolt housing to permit the faceplate and backplate to be tilted about a vertical axis to accommodate the faceplate to beveled doors. By such a structure the axis of tilt extends through the hole in the housing which would correspond with the slot 18 of FIG. 8. However, it will be apparent if the axis of tilt of the backplate 10 were through the slot 18 the faceplate 11 would, while tilting, swing to opposite sides of the central vertical plane of housing 1. In such a case it is necessary to make the hole 25 of the faceplate 11 (FIG. 2) extremely wide to permit the bolt to pass therethrough when the door is provided with an extremely large bevel.

By the structure shown in FIGS. 8-12 it is apparent that the faceplate tilts about an axis corresponding to its own central axis so that the bolt hole 25 in faceplate 11 need only be slightly wider than the thickness of the bolt. Thus an unsightly large clearance between the bolt hole and the bolt is avoided.

The above described structure also lends itself to use with unbeveled doors and to rabbeted doors as seen in FIGS. 1-5.

In FIGS. 1, 2, a jamb 30 is rabbeted to provide a shoulder 31 and offset face 32. The door 33 is similarly rabbeted to provide a shoulder 34 and offset face 35. It will be understood when the door is closed the shoulders 31, 34 are in face to face opposed relationship and face 35 of door 33 is alongside face 36 of jamb 30.

Face 36 of jamb 30 is recessed and provided with a strike plate 38 having a hole 39 for receiving therethrough the bolt 40 when the door 33 is locked. To accommodate the backplate generally designated 41 the door 33 is provided with a relatively large notch 42 and the jamb 30 is correspondingly provided with a notch 43 which may be reinforced by a channel shaped strip 44.

In order to bring the faceplate 11 to coplanar relationship with the face 35 of door 33 the backplate 41 is boxed by bending vertical flanges 46, 47 and horizontal flanges 48, 49 (FIG. 3) from the material of the backplate. A central hole 50 is provided for bolt 40 and a pair of upper and lower lugs 51, 52 are provided identical to lug 19 hereinbefore described for connecting the backplate to housing 1 (FIG. 5).

Faceplate 11 is provided with countersunk upper and lower holes 54 for receiving therethrough woodscrews (not shown) for securement of the faceplate and backplate to door 33.

In the case of a rabbeted door the edge 35 of the door 33 is, of course, perpendicular to the opposite faces of the door and it is therefor not required that the faceplate be tiltable relative to the housing 1. For this reason the lugs 51, 52 may be formed so that they completely fill the arcuate slots 18 in housing 1 (FIG. 4) thereby firmly securing the housing relative to the faceplate and backplate.

In order to provide for both beveled and unbeveled doors the lug 19 of FIG. 8 may be formed with a slit or slot 53 adjacent each end to provide a tab 55 which may be bent upwardly by means of pliers if it is desired to reduce the effective length of the lug for use on beveled doors.

Another method of securing the housing relative to the faceplate is shown in FIGS. 6, 7. In this case the top and bottom of housing 1 may be apertured as at 57 (FIG. 7) to receive one end of a locking clamp 58 therethrough. The opposite end of the clamp 58 is serrated as indi-

cated at 59 (FIG. 6) to frictionally engage and be embedded into the lug 19. A screw 60 is passed through clamp 58 and is threadedly engaged in top 2 of housing 1 so that upon tightening said screw the backplate 10 is firmly secured to the housing.

FIGURES 14, 15 illustrate the manner in which the invention may be employed with conventional cylindrical locks in which the latch bolt housing is cylindrical. In such a case it is merely necessary to provide arcuate slots 63 in the sidewalls 64 of the latch bolt housing and complementarily formed lugs 65 on the backplate 66. The center of curvature of slots 63 of course passes through faceplate 67 (FIG. 15).

The above specific description of the preferred form of the invention is not to be taken as restrictive of the same as it is obvious that minor variations in design may be resorted to without departing from the spirit of the invention.

I claim:

1. In a latch structure that includes a latch bolt housing and a faceplate carried by said housing and adapted to be secured to the edge of the door through which the bolt projects, said housing being provided with similar arcuate slots in the top and bottom sides thereof, vertically spaced extensions carried by said faceplate and received in said slots respectively, said extensions being elongated in the direction of said slots and being formed to completely fill said slots to prevent relative tilting movement between said faceplate and housing, and being provided with deformable lugs adapted to be bent out of engagement with said slots to permit relative tilting movement of said faceplate and housing.

2. In a latch structure that includes a latch bolt housing and a faceplate carried by said housing and adapted to be secured to the edge of the door through which the bolt projects, an elongated slot in said housing, said slot being in the form of a circular arc, an extension integral with said faceplate and having an arcuate portion received in said slot for connecting said faceplate and said housing together, said portion being elongated in the direction of said slot and the side of said portion being formed complementary to and having the same center of curvature as the sides of said slot, said portion being shorter than said slot to permit movement of said portion along the length of said slot whereby said plate may be tilted about said center of curvature.

3. In a latch structure that includes a latch bolt housing and a faceplate carried by said housing and adapted to be secured to the edge of the door through which the bolt projects, an elongated arcuate slot in said housing, an extension integral with said faceplate and having an arcuate portion received in said slot for connecting said faceplate and said housing together, said portion being elongated in the direction of said slot and the sides of said portion being formed complementary to and having the same center of curvature as the sides of said slot, said portion being shorter than said slot to permit movement of said portion along the length of said slot whereby said plate may be tilted about said center of curvature, said center of curvature being within said faceplate when said portion is in said slot.

References Cited in the file of this patent.

UNITED STATES PATENTS

166,797	Mix et al.	Aug. 17, 1875
235,963	Prouty	Dec. 28, 1880
332,849	Voll	Dec. 22, 1885
2,413,732	Schlage	Jan. 7, 1947
2,629,250	Schlage	Feb. 24, 1953

FOREIGN PATENTS

788	Great Britain	1894
-----	---------------------	------