

(12) UK Patent Application

(19) GB (11) 2 432 499 (13) A

(43) Date of A Publication 23.05.2007

(21) Application No: 0623156.7  
(22) Date of Filing: 21.11.2006  
(30) Priority Data:  
(31) 2005336046 (32) 21.11.2005 (33) JP

(51) INT CL:  
G06T 1/20 (2006.01) G06T 15/20 (2006.01)  
(52) UK CL (Edition X ):  
H4T TBAD  
(56) Documents Cited:  
US 20060221073 A1 US 20060044313 A1  
(58) Field of Search:  
UK CL (Edition X ) H4T  
INT CL G06T  
Other:

(71) Applicant(s):  
NAMCO BANDAI Games Inc.  
(Incorporated in Japan)  
1-21, Yaguchi 2-chome, Ota-ku,  
Tokyo 146-8655, Japan  
(72) Inventor(s):  
Takashi Imagire  
(74) Agent and/or Address for Service:  
Page Hargrave  
Southgate, Whitefriars, Lewins Mead,  
BRISTOL, BS1 2NT, United Kingdom

(54) Abstract Title: Image generation of objects distant from and near to a virtual camera

(57) An image generation system including a vertex processing section and a pixel processing section. When subjecting an object which is distant from a virtual camera to predetermined processing which is implemented by a first processing and a second processing, the vertex processing section performs the first processing with a processing load lower than a processing load of the second processing, and the pixel processing section performs the second processing. When subjecting an object which is close to the virtual camera to the predetermined processing which is implemented by a third processing and a fourth processing, the vertex processing section performs the third processing with a processing load higher than a processing load of the fourth processing, and the pixel processing section performs the fourth processing.

FIG.5A

OBJECT DISTANT FROM VIRTUAL CAMERA  
(OBJECT WHICH OCCUPIES SMALL AREA ON SCREEN)

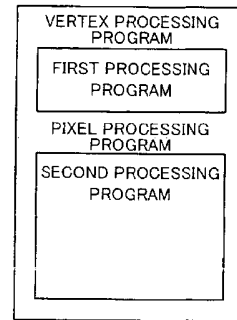
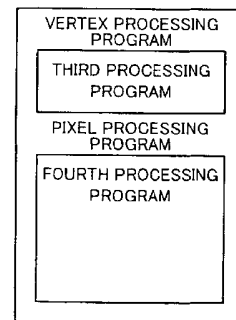

FIG.5B

OBJECT CLOSE TO VIRTUAL CAMERA  
(OBJECT WHICH OCCUPIES LARGE AREA ON SCREEN)



GB 2 432 499 A

FIG.1

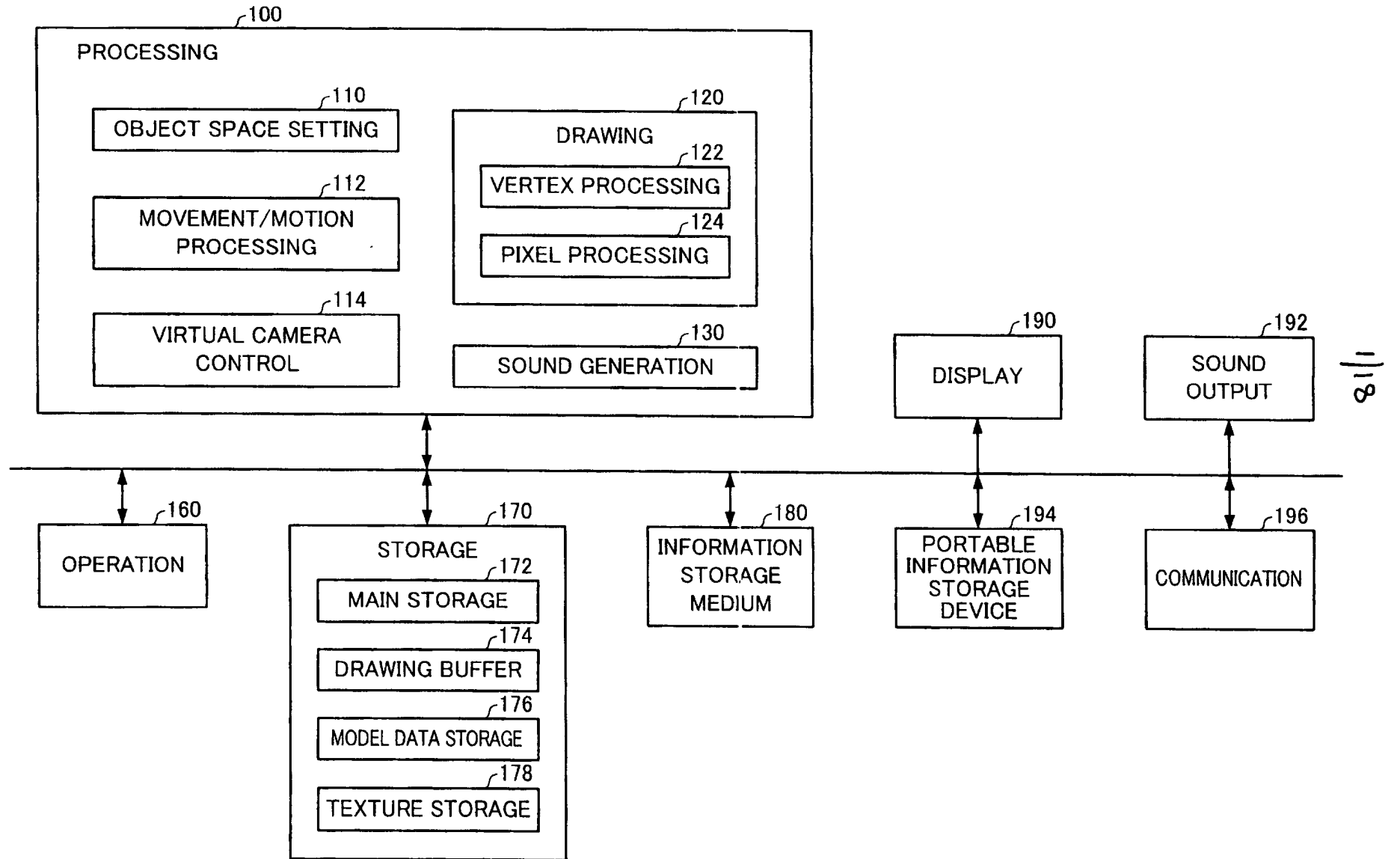

FIG.2

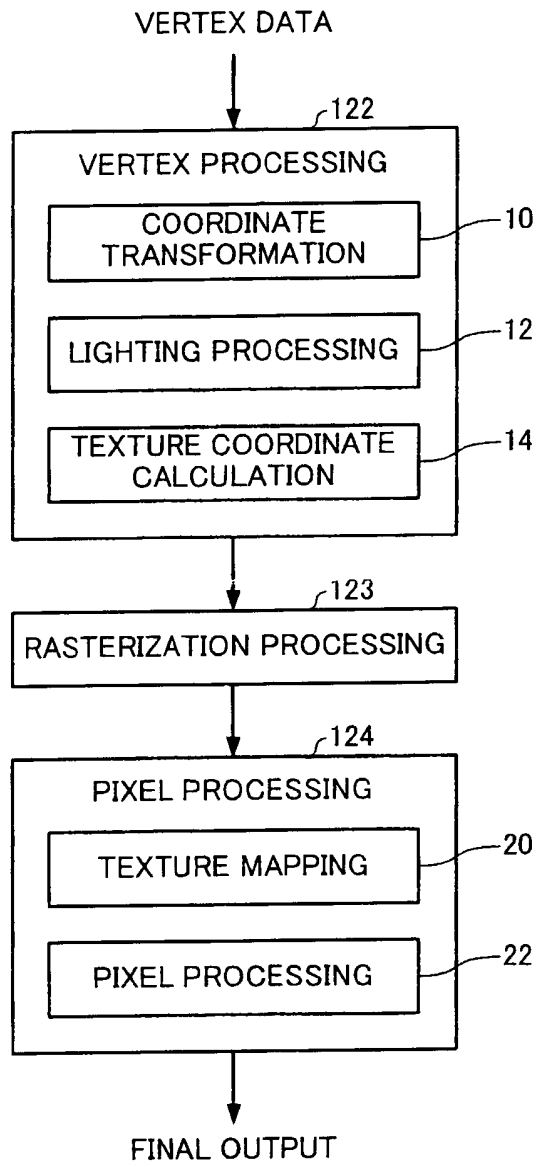

FIG.3A

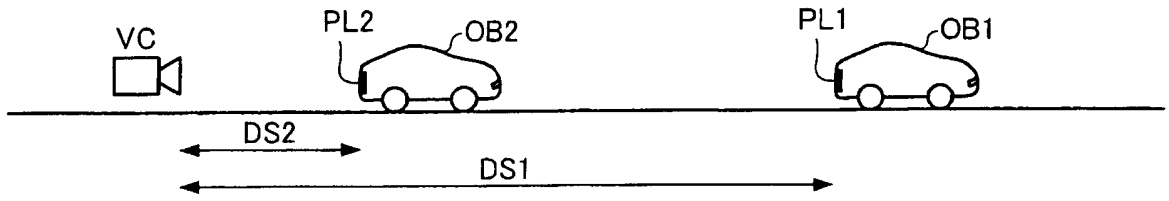

FIG.3B

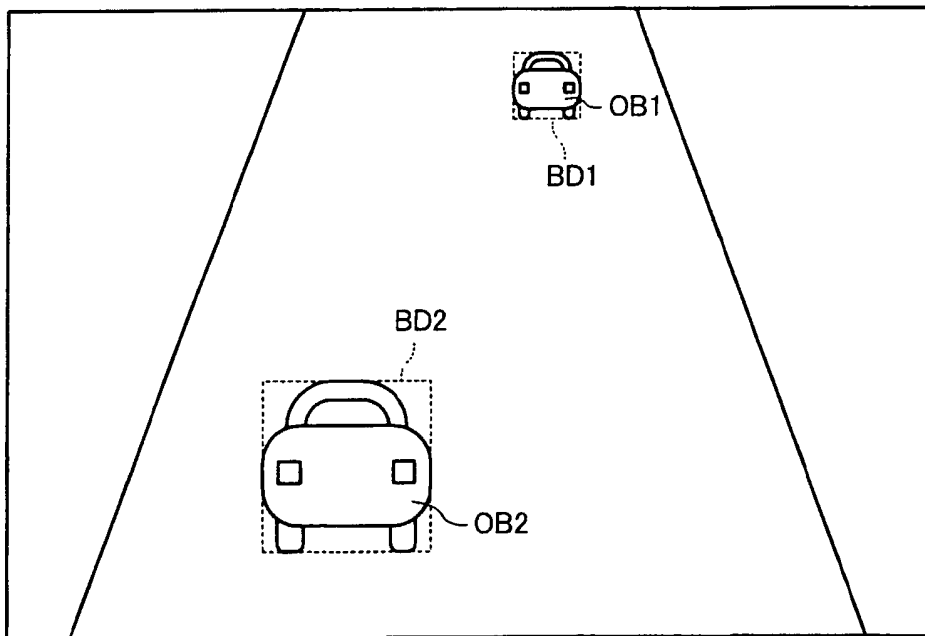

FIG.4A

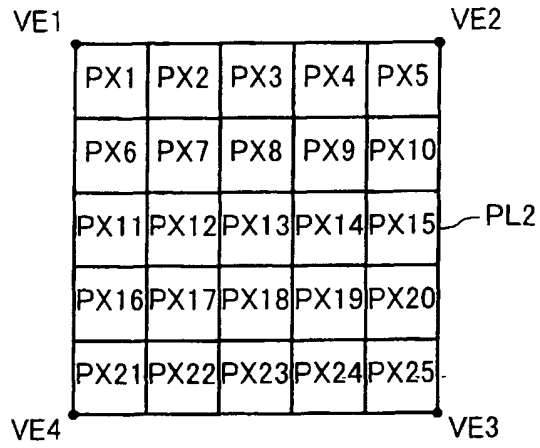

FIG.4B

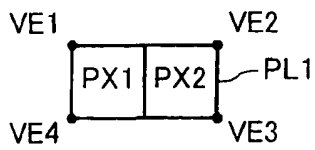

FIG.4C

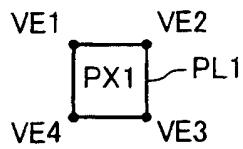

FIG.5A

OBJECT DISTANT FROM VIRTUAL CAMERA  
(OBJECT WHICH OCCUPIES SMALL AREA ON SCREEN)

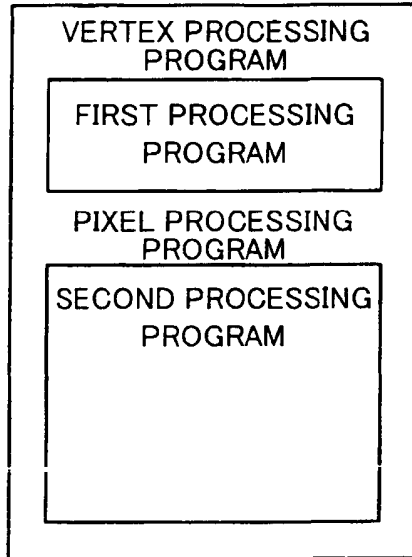

FIG.5B

OBJECT CLOSE TO VIRTUAL CAMERA  
(OBJECT WHICH OCCUPIES LARGE AREA ON SCREEN)

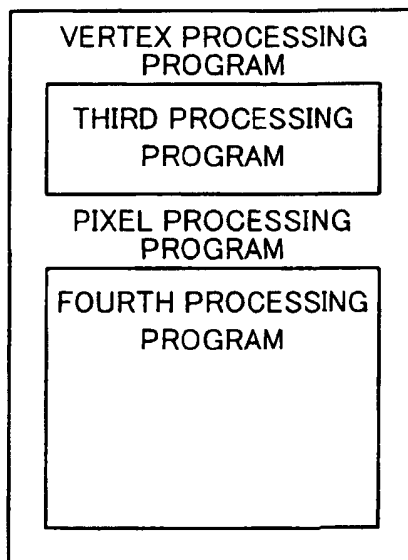

FIG.6A

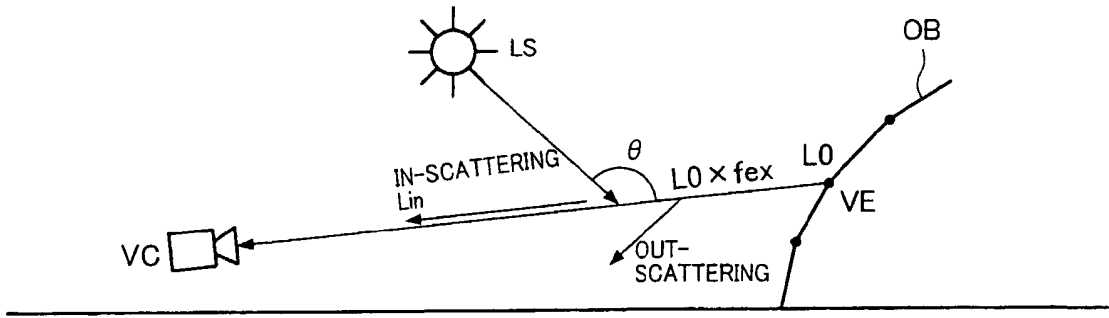

FIG.6B

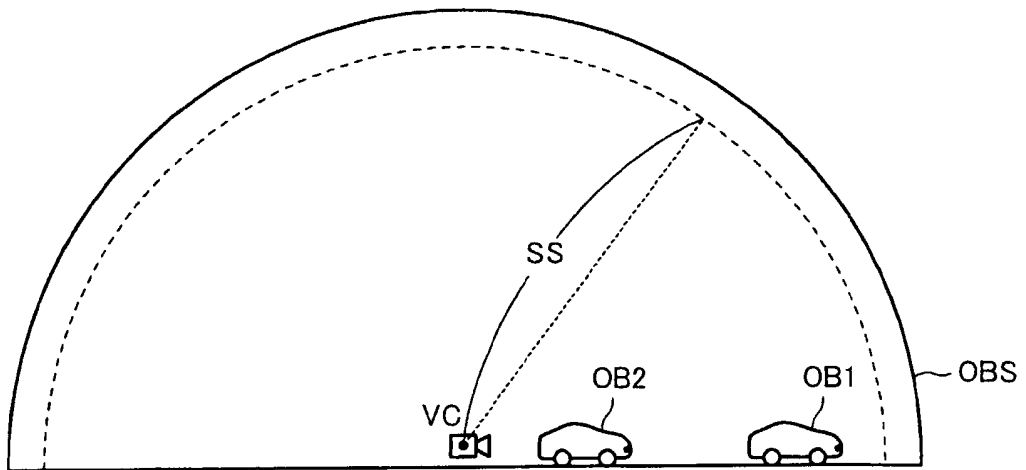

FIG.7

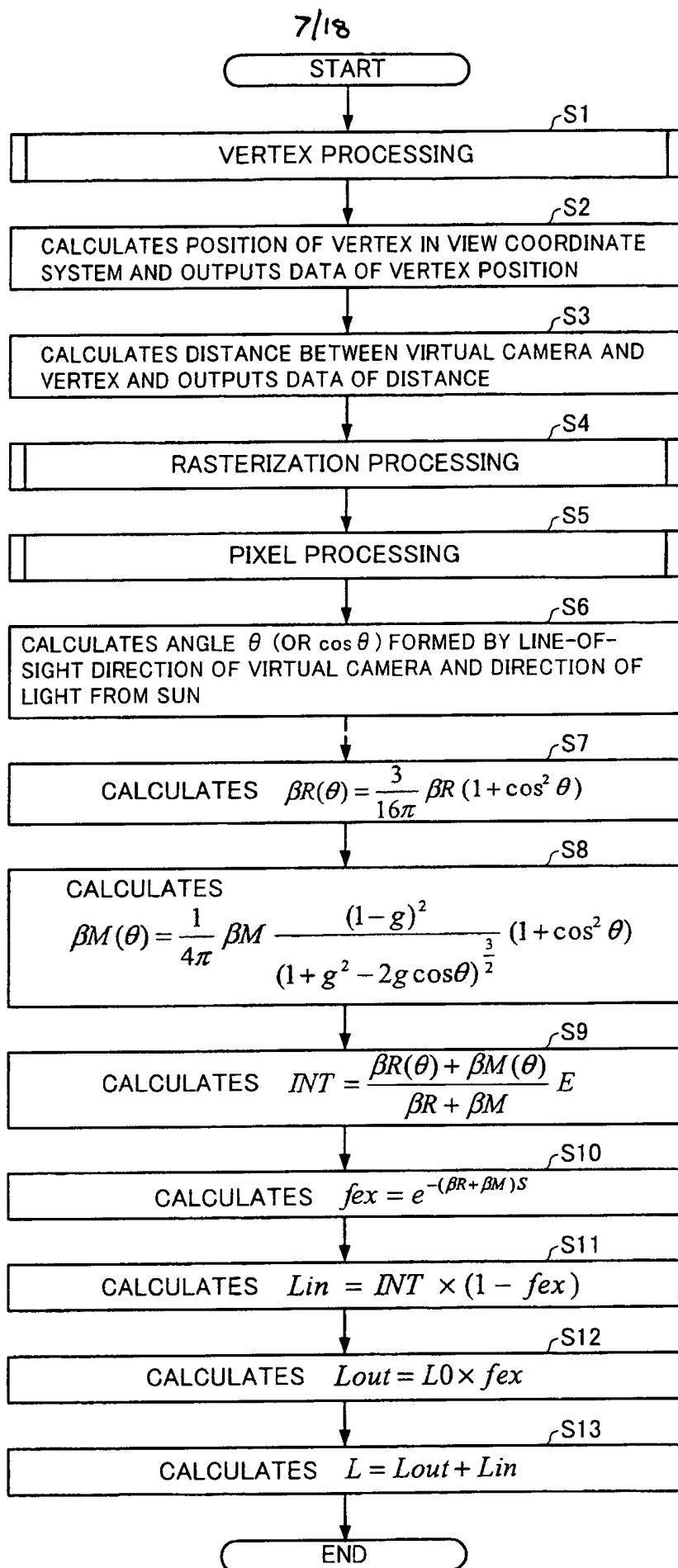

FIG.8

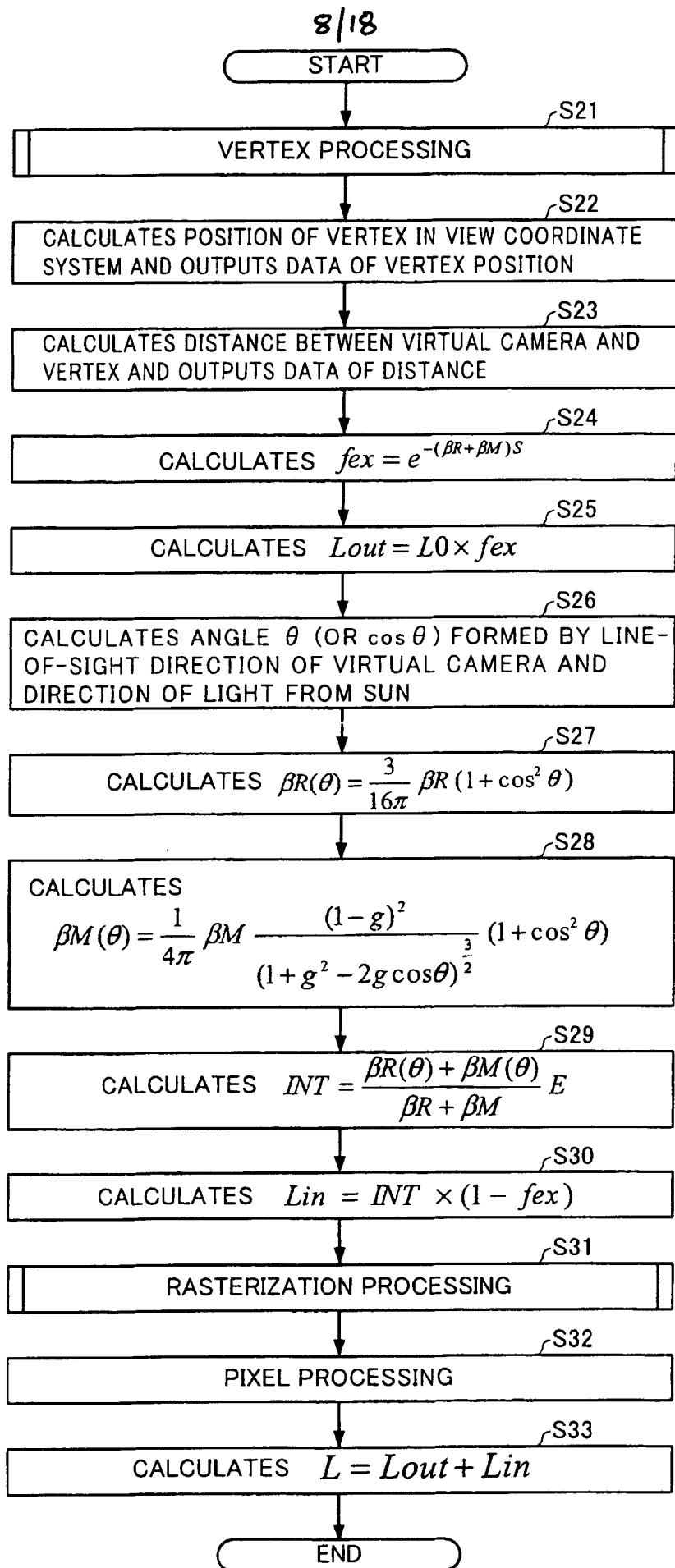

FIG.9

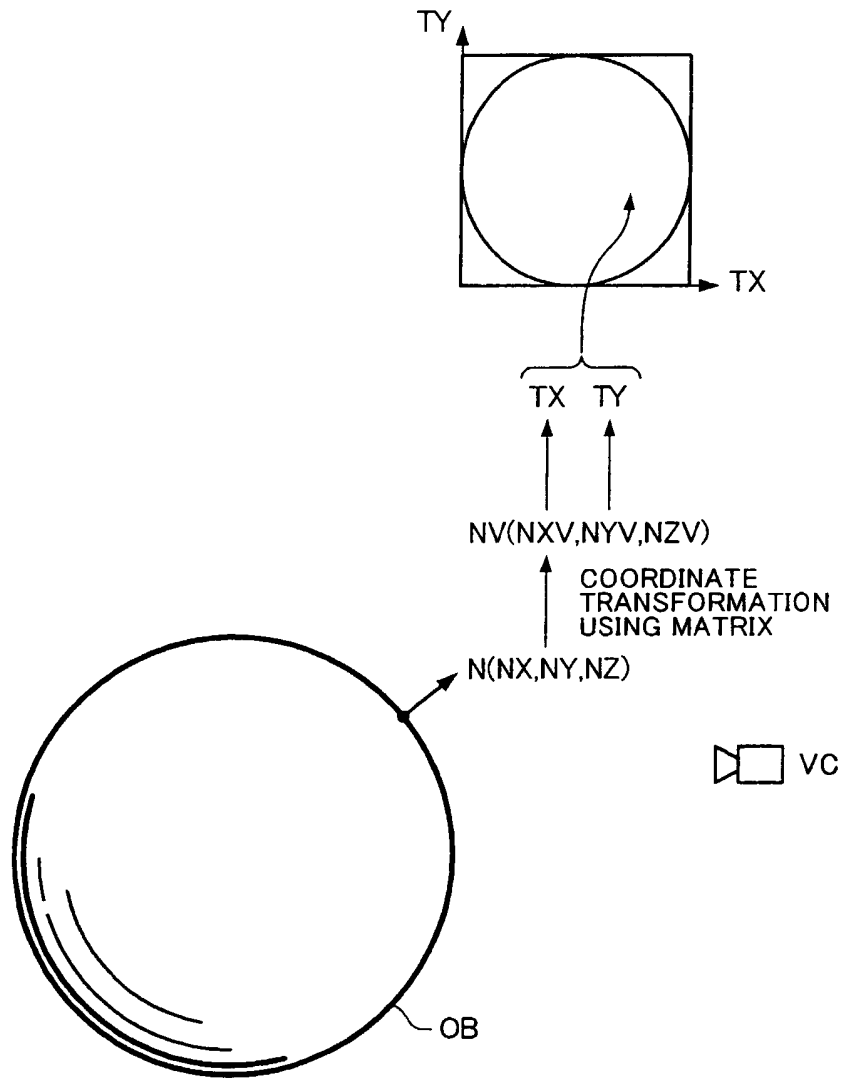

FIG.10

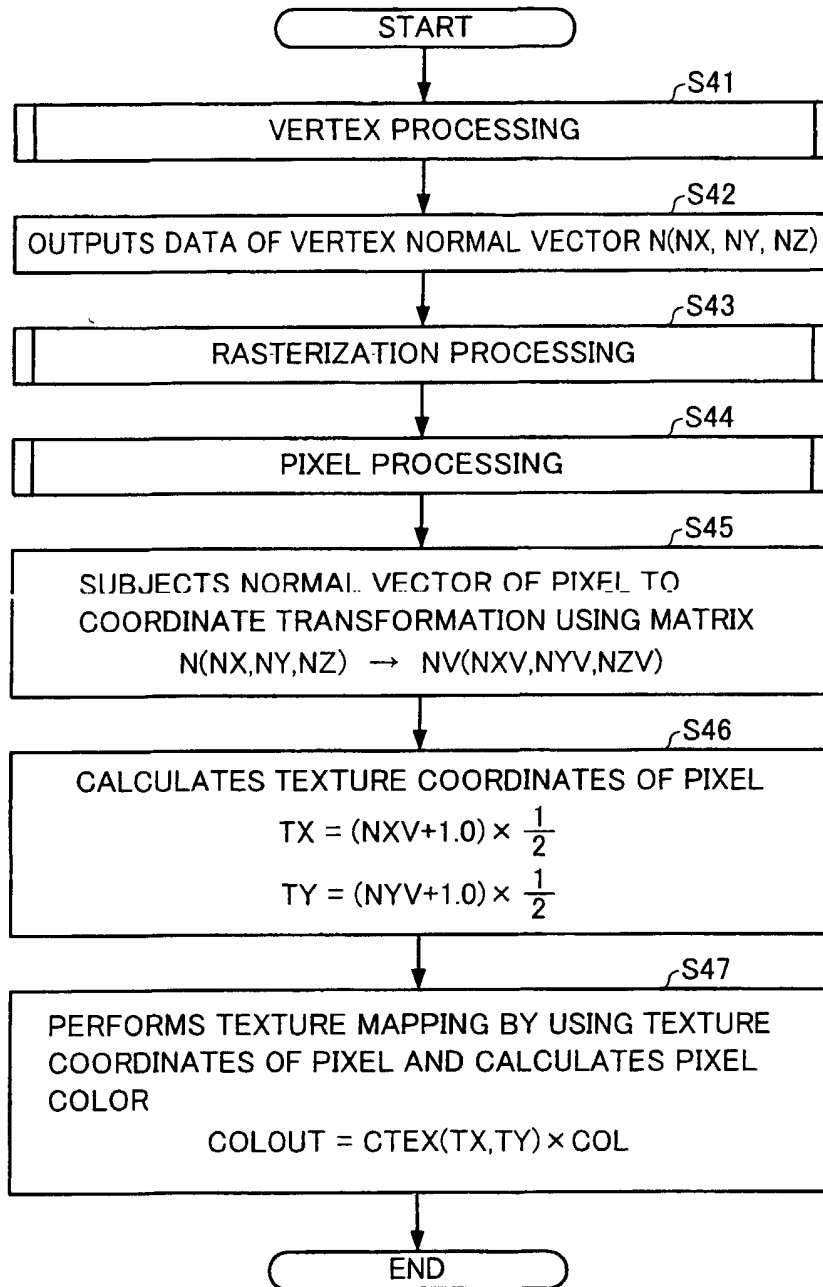

FIG.11

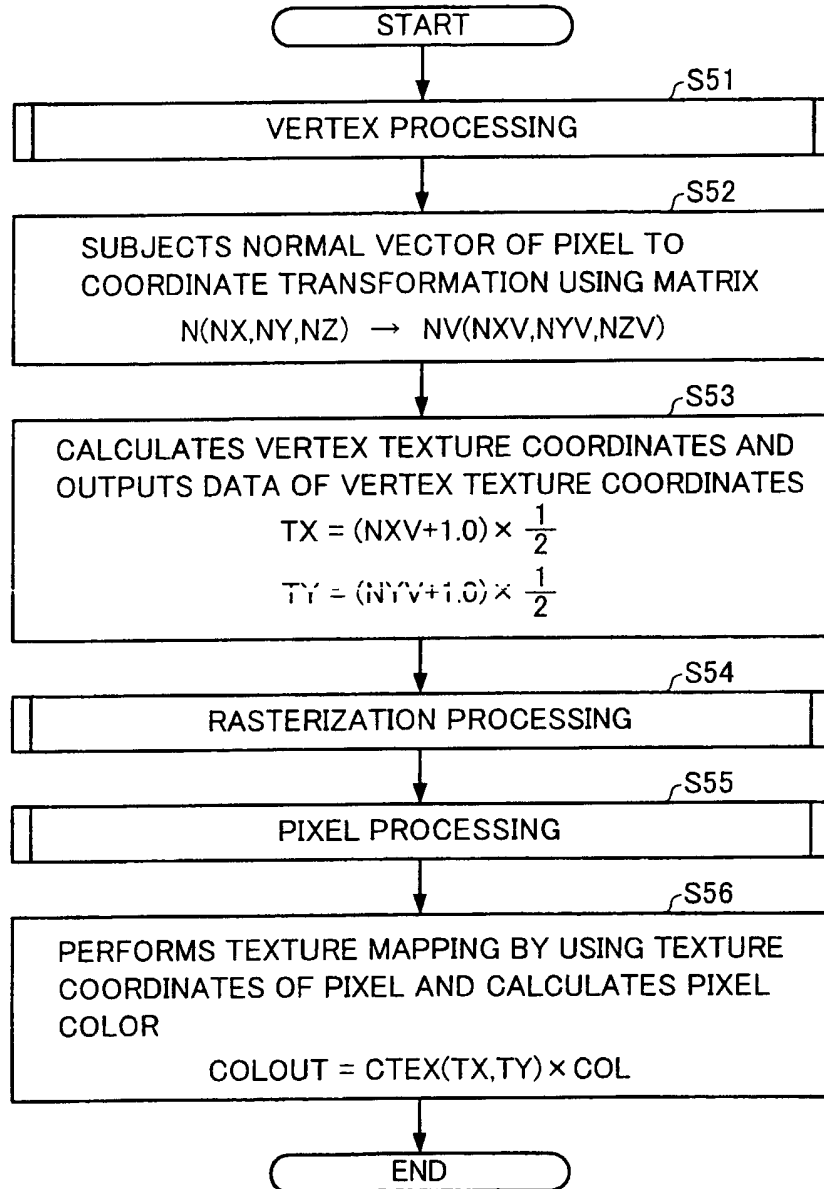
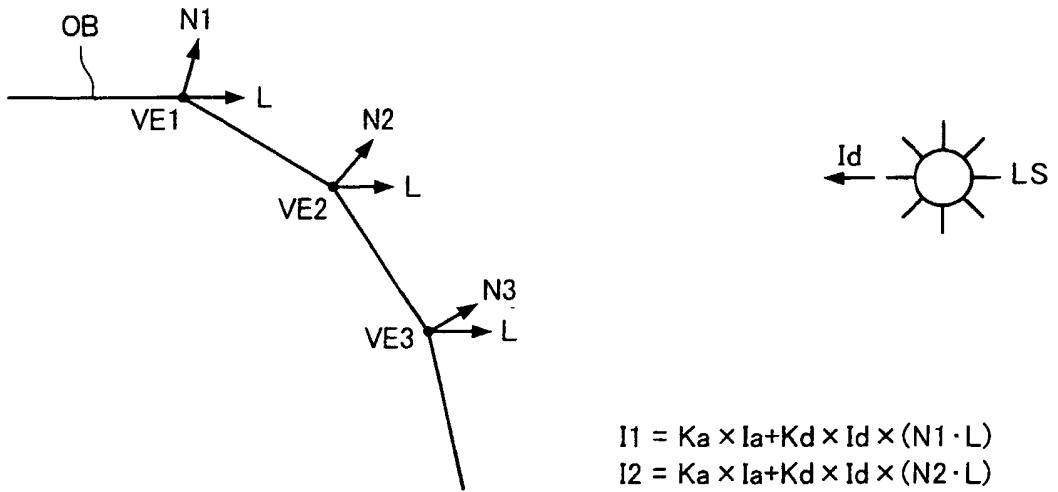

FIG.12A



$$I_1 = K_a \times I_a + K_d \times I_d \times (N_1 \cdot L)$$

$$I_2 = K_a \times I_a + K_d \times I_d \times (N_2 \cdot L)$$

$$I_3 = K_a \times I_a + K_d \times I_d \times (N_3 \cdot L)$$

FIG.12B

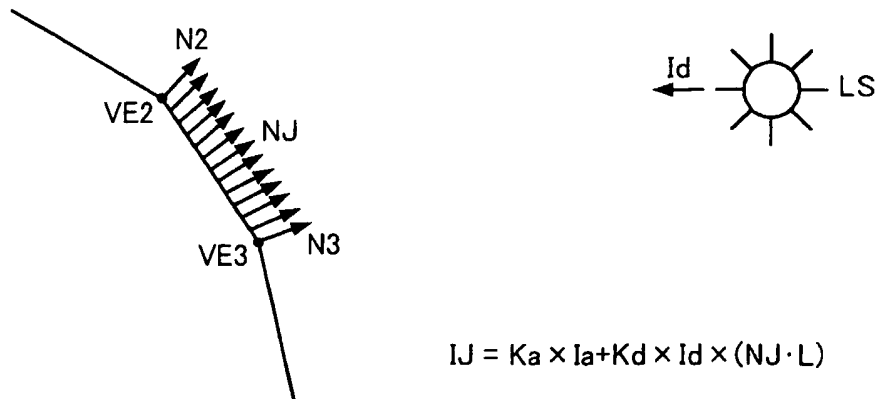

$$I_J = K_a \times I_a + K_d \times I_d \times (N_J \cdot L)$$

FIG.13

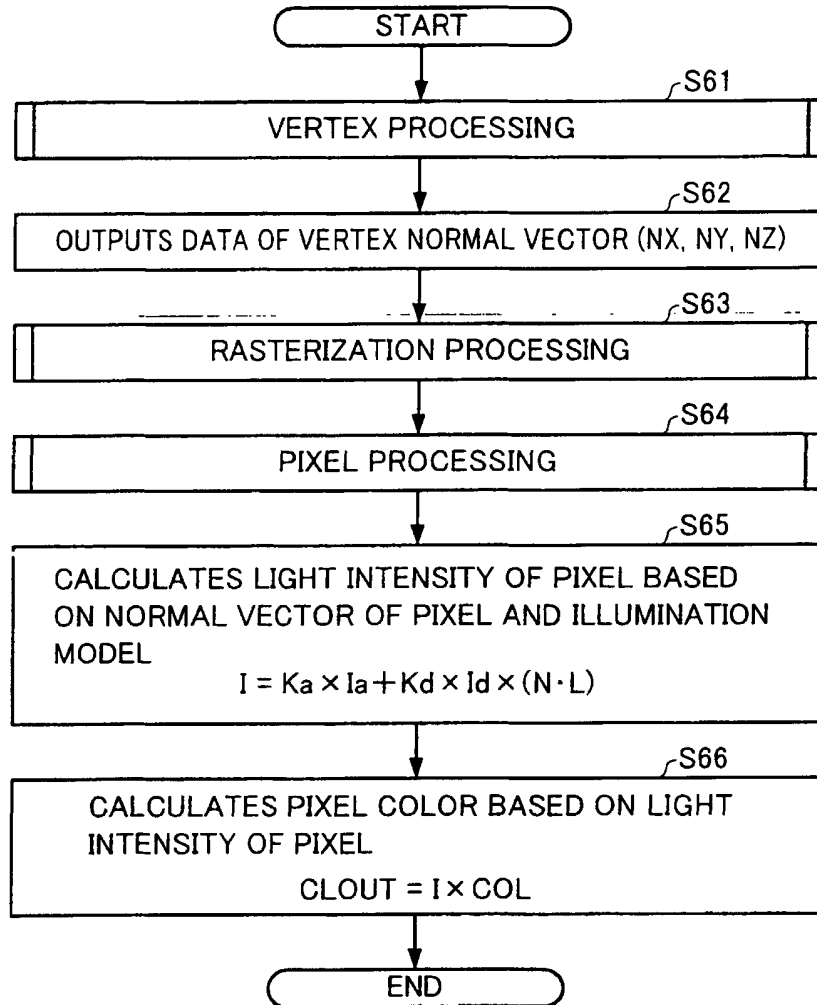

FIG.14

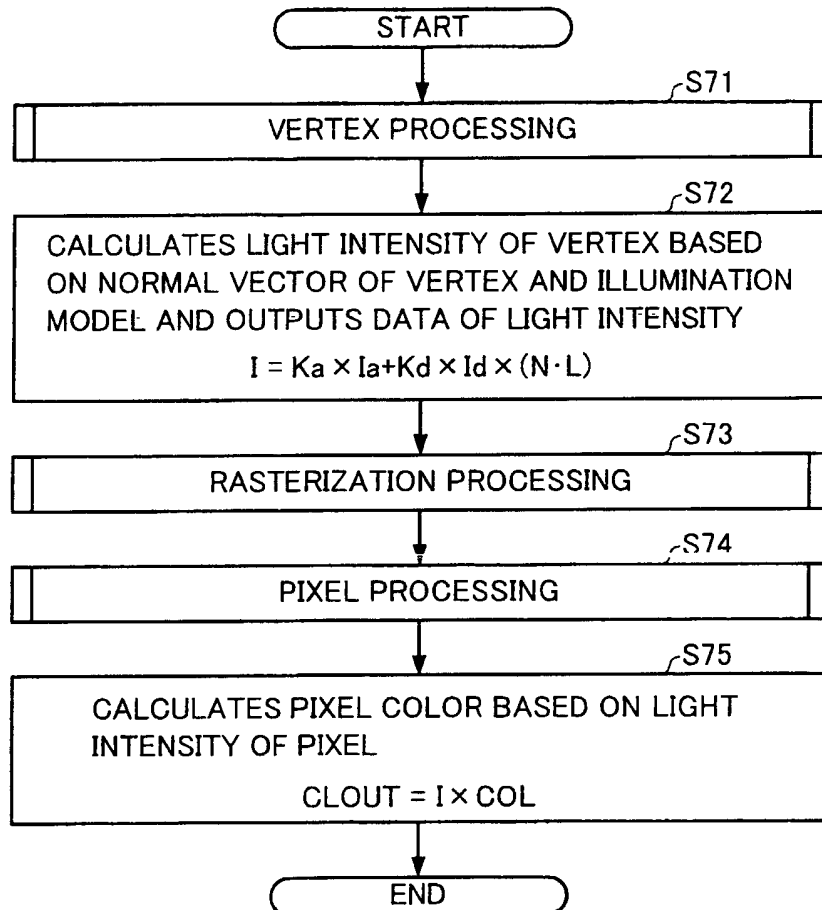

FIG.15A

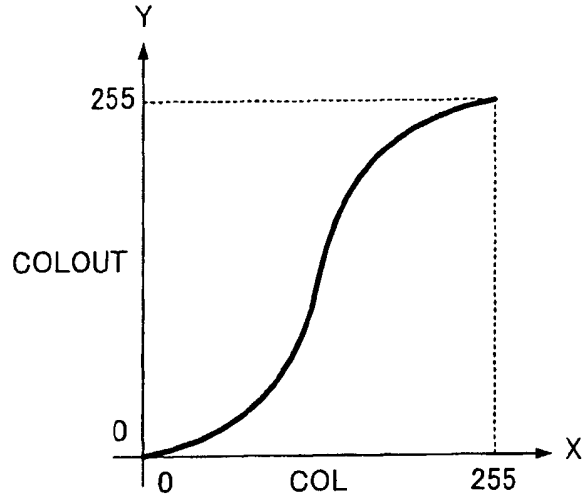

FIG.15B

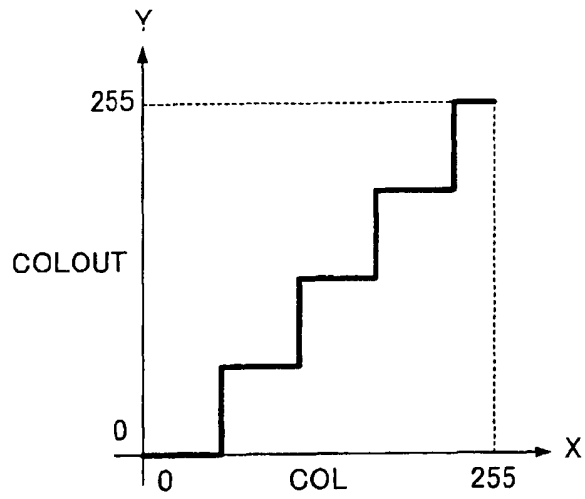

FIG.15C

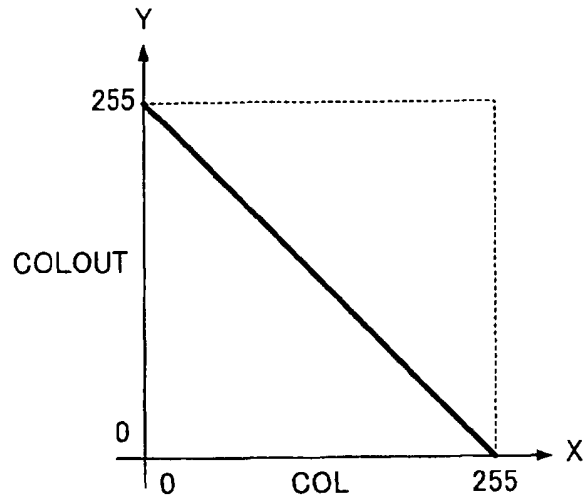

FIG.16

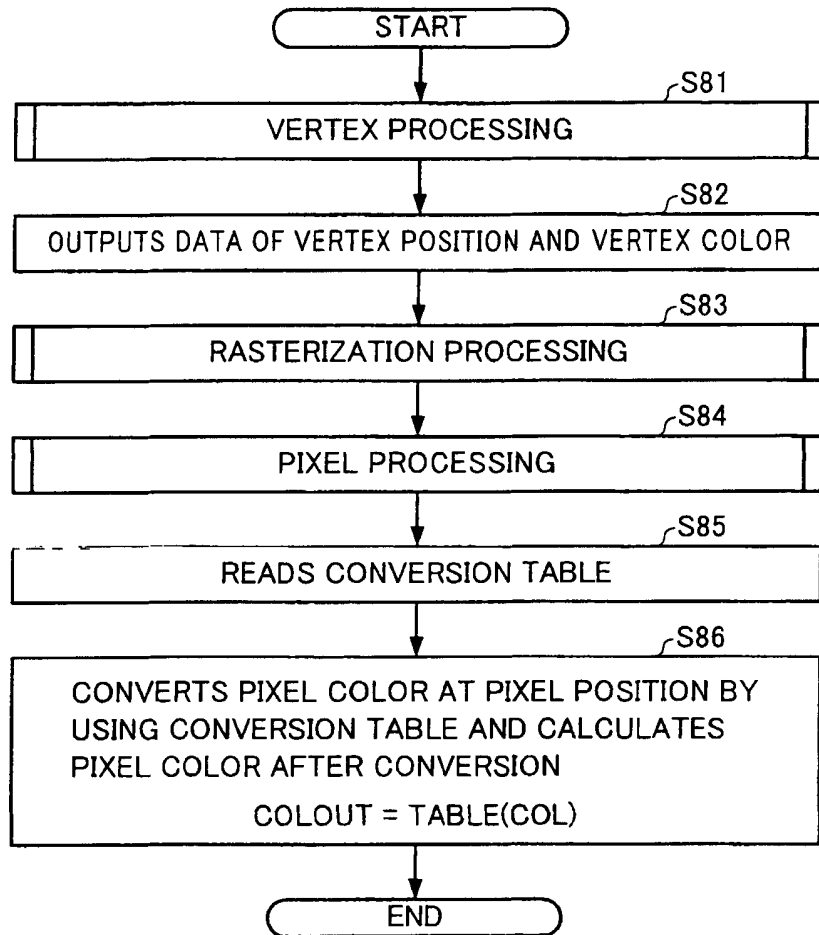

FIG.17

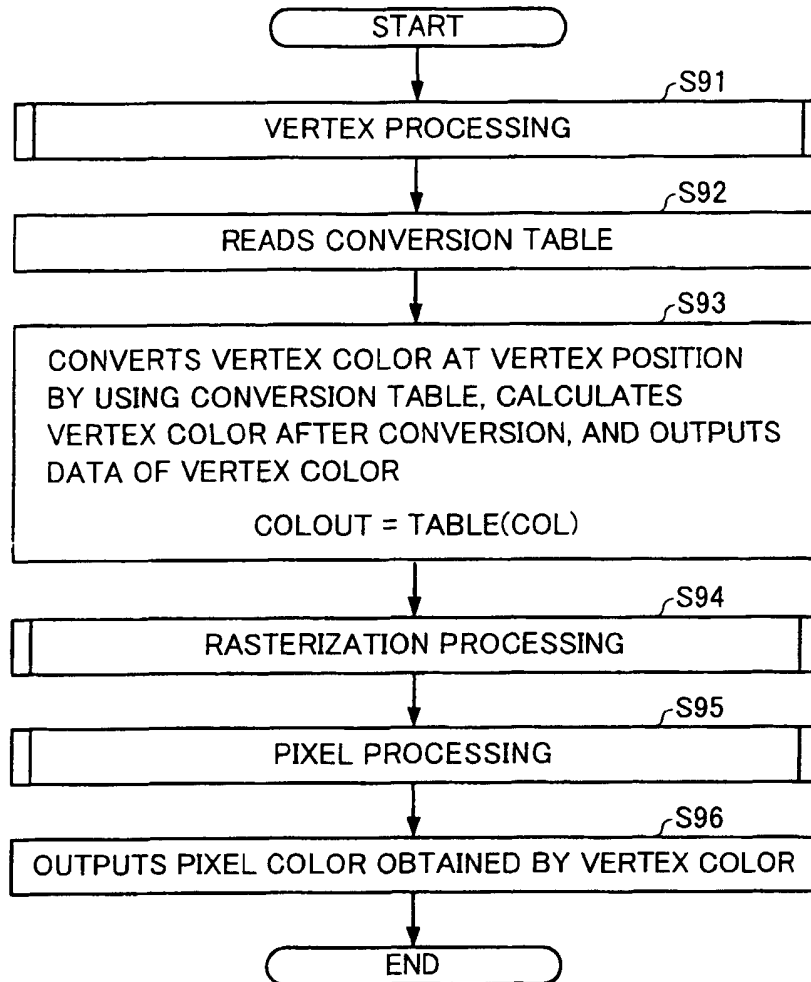
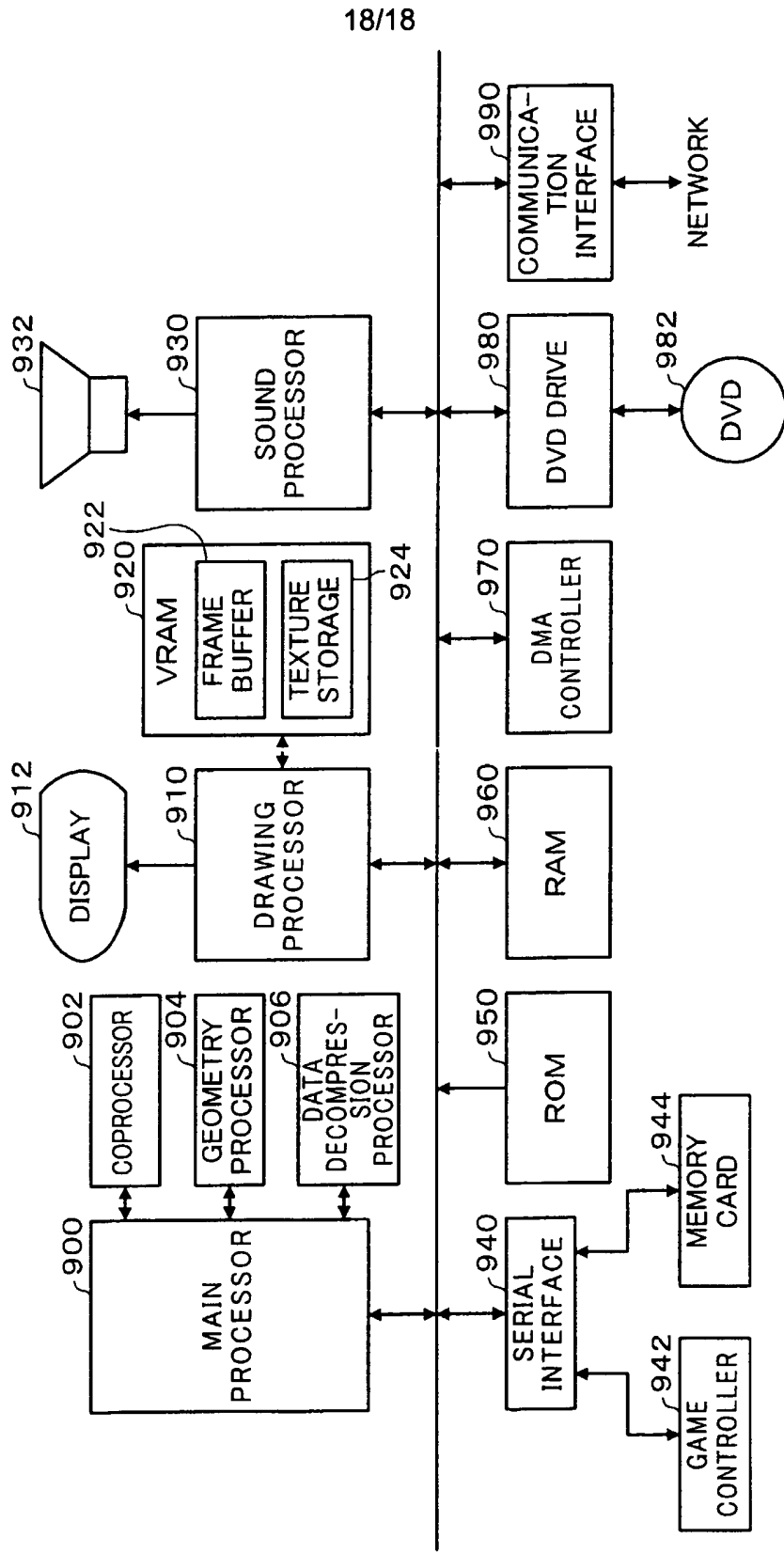

FIG.18



PROGRAM, INFORMATION STORAGE MEDIUM, AND  
IMAGE GENERATION SYSTEM

BACKGROUND OF THE INVENTION

5           The present invention relates to a program, an information storage medium, and an image generation system.

          An image generation system (game system) has been known which generates an image viewed from a virtual camera (given viewpoint) in an object space (virtual three-dimensional space) in which an object such as a car or a character is disposed.

10          Such an image generation system is very popular as a system which enables a user to experience so-called virtual reality.

          Such an image generation system involves vertex processing performed in vertex units (per-vertex processing) and pixel processing performed in pixel units (per-pixel processing).

15          In a known image generation system, assignment of processing to a vertex processing section which performs vertex processing and a pixel processing section which performs pixel processing has not been sufficiently taken into consideration. Therefore, vertex processing or pixel processing may be unnecessarily performed.

          JP-A-2002-373348 discloses related-art technology in this field.

20

SUMMARY

          According to a first aspect of the invention, there is provided a program for generating an image, the program causing a computer to function as:

          an object space setting section which sets an object in an object space;

25           a vertex processing section which performs per-vertex processing; and

          a pixel processing section which performs per-pixel processing,

          wherein, when subjecting a first object which is distant from a virtual camera to

predetermined processing which is implemented by a first processing and a second processing, the vertex processing section performs the first processing with a processing load lower than a processing load of the second processing, and the pixel processing section performs the second processing; and

5            wherein, when subjecting a second object which is closer to the virtual camera than the first object to the predetermined processing which is implemented by a third processing and a fourth processing, the vertex processing section performs the third processing with a processing load higher than a processing load of the fourth processing, and the pixel processing section performs the fourth processing.

10           According to a second aspect of the invention, there is provided a program for generating an image, the program causing a computer to function as:

an object space setting section which sets an object in an object space;

a vertex processing section which performs per-vertex processing; and

a pixel processing section which performs per-pixel processing,

15           wherein, when subjecting a first object which occupies a small area on a screen to predetermined processing which is implemented by a first processing and a second processing, the vertex processing section performs the first processing with a processing load lower than a processing load of the second processing, and the pixel processing section performs the second processing; and

20           wherein, when subjecting a second object which occupies a larger area on the screen than the first object to the predetermined processing which is implemented by a third processing and a fourth processing, the vertex processing section performs the third processing with a processing load higher than a processing load of the fourth processing, and the pixel processing section performs the fourth processing.

25           According to a third aspect of the invention, there is provided a computer-readable information storage medium storing any of the above-described programs.

According to a fourth aspect of the invention, there is provided an image generation system which generates an image, comprising:

an object space setting section which sets an object in an object space;

a vertex processing section which performs per-vertex processing; and

5 a pixel processing section which performs per-pixel processing,

wherein, when subjecting a first object which is distant from a virtual camera to predetermined processing which is implemented by a first processing and a second processing, the vertex processing section performs the first processing with a processing load lower than a processing load of the second processing, and the pixel processing section performs the second processing; and

10

wherein, when subjecting a second object which is closer to the virtual camera than the first object to the predetermined processing which is implemented by a third processing and a fourth processing, the vertex processing section performs the third processing with a processing load higher than a processing load of the fourth processing, and the pixel processing section performs the fourth processing.

15

According to a fifth aspect of the invention, there is provided an image generation system which generates an image, comprising:

an object space setting section which sets an object in an object space;

a vertex processing section which performs per-vertex processing; and

20 a pixel processing section which performs per-pixel processing,

wherein, when subjecting a first object which occupies a small area on a screen to predetermined processing which is implemented by a first processing and a second processing, the vertex processing section performs the first processing with a processing load lower than a processing load of the second processing, and the pixel processing section performs the second processing; and

25

wherein, when subjecting a second object which occupies a larger area on the screen than the first object to the predetermined processing which is implemented by a

third processing and a fourth processing, the vertex processing section performs the third processing with a processing load higher than a processing load of the fourth processing, and the pixel processing section performs the fourth processing.

5 BRIEF DESCRIPTION OF THE SEVERAL VIEWS OF THE DRAWING

FIG. 1 is an example of a functional block diagram of an image generation system according to one embodiment of the invention.

FIG. 2 shows a configuration example of a vertex processing section and a pixel processing section.

10 FIGS. 3A and 3B are views illustrative of a method of assigning processing to the vertex processing section and the pixel processing section.

FIGS. 4A to 4C are views illustrative of an increase in processing efficiency using a method according to one embodiment of the invention.

15 FIGS. 5A and 5B show program description examples for a long-distance object and a short-distance object.

FIGS. 6A and 6B are views illustrative of light scattering processing.

FIG. 7 is a flowchart of light scattering processing for a long-distance object.

FIG. 8 is a flowchart of light scattering processing for a short-distance object.

FIG. 9 is a view illustrative of texture coordinate calculation processing.

20 FIG. 10 is a flowchart of texture coordinate calculation processing for a long-distance object.

FIG. 11 is a flowchart of texture coordinate calculation processing for a short-distance object.

FIGS. 12A and 12B are views illustrative of lighting processing.

25 FIG. 13 is a flowchart of lighting processing for a long-distance object.

FIG. 14 is a flowchart of lighting processing for a short-distance object.

FIGS. 15A to 15C are views illustrative of color conversion processing.

FIG. 16 is a flowchart of color conversion processing for a long-distance object.

FIG. 17 is a flowchart of color conversion processing for a short-distance object.

FIG. 18 shows a hardware configuration example.

5

## DETAILED DESCRIPTION OF THE EMBODIMENT

The invention may provide a program, an information storage medium, and an image generation system which enable efficient assignment of processing to a vertex processing section and a pixel processing section.

According to one embodiment of the invention, there is provided an image  
10 generation system which generates an image, comprising:

an object space setting section which sets an object in an object space;

a vertex processing section which performs per-vertex processing; and

a pixel processing section which performs per-pixel processing,

wherein, when subjecting a first object which is distant from a virtual camera to  
15 predetermined processing which is implemented by a first processing and a second processing, the vertex processing section performs the first processing with a processing load lower than a processing load of the second processing, and the pixel processing section performs the second processing; and

wherein, when subjecting a second object which is closer to the virtual camera  
20 than the first object to the predetermined processing which is implemented by a third processing and a fourth processing, the vertex processing section performs the third processing with a processing load higher than a processing load of the fourth processing, and the pixel processing section performs the fourth processing.

According to one embodiment of the invention, there is provided a program  
25 causing a computer to function as the above-described sections. According to one embodiment of the invention, there is provided a computer-readable information storage medium storing a program causing a computer to function as the above-described

sections.

In these embodiment, when subjecting the first object which is distant from the virtual camera to the predetermined processing, the pixel processing section performs the main processing with a high load. On the other hand, when subjecting the second object  
5 close to the virtual camera to the predetermined processing, the vertex processing section performs the main processing with a high load. This enables efficient assignment of the processing to the vertex processing section and the pixel processing section, whereby the processing efficiency can be improved, and the quality of the generated image can be maintained, for example.

10 The term “high load” used herein refers to a case where the amount (number of steps) of at least one of functions and variables described in the program which implements the processing is large, a case where the functions are complicated (the number of orders is large), and the like. The term “low load” used herein refers to a case  
15 where the amount of at least one of functions and variables described in the program which implements the processing is small, a case where the functions are simple (the number of orders is small), and the like.

According to one embodiment of the invention, there is provided an image generation system which generates an image, comprising:

20 an object space setting section which sets an object in an object space;  
a vertex processing section which performs per-vertex processing; and  
a pixel processing section which performs per-pixel processing,

wherein, when subjecting a first object which occupies a small area on a screen to predetermined processing which is implemented by a first processing and a second processing, the vertex processing section performs the first processing with a processing  
25 load lower than a processing load of the second processing, and the pixel processing section performs the second processing; and

wherein, when subjecting a second object which occupies a larger area on the

screen than the first object to the predetermined processing which is implemented by a third processing and a fourth processing, the vertex processing section performs the third processing with a processing load higher than a processing load of the fourth processing, and the pixel processing section performs the fourth processing.

5           According to one embodiment of the invention, there is provided a program causing a computer to function as the above-described sections. According to one embodiment of the invention, there is provided a computer-readable information storage medium storing a program causing a computer to function as the above-described sections.

10           In these embodiment, when subjecting the object of the first group which occupies a small area on the screen to the predetermined processing, the pixel processing section performs the main processing with a high load. On the other hand, when subjecting the object of the second group which occupies a large area on the screen to the predetermined processing, the vertex processing section performs the main processing with a high load.

15           This enables efficient assignment of the processing to the vertex processing section and the pixel processing section, whereby the processing efficiency can be improved, and the quality of the generated image can be maintained, for example.

          In each of the image generation system, program, and information storage medium, the predetermined processing may be light scattering processing.

20           This enables efficient light scattering processing, whereby scattering of light can be simulated.

          In each of the image generation system, program, and information storage medium,

          the vertex processing section may perform the first processing which includes  
25           calculating a distance between the virtual camera and a vertex of an object; and

          the pixel processing section may perform the second processing which includes calculating a pixel color by out-scattering and a pixel color by in-scattering and adding

the pixel color by out-scattering and the pixel color by in-scattering.

This allows the low-load first processing of the light scattering processing to be assigned to the vertex processing section and allows the high-load second processing to be assigned to the pixel processing section.

5 In each of the image generation system, program, and information storage medium,

the vertex processing section may perform the third processing which includes calculating a vertex color by out-scattering and a vertex color by in-scattering; and

10 the pixel processing section may perform the fourth processing which includes adding a pixel color by out-scattering and a pixel color by in-scattering.

This allows the high-load third processing of the light scattering processing to be assigned to the vertex processing section and allows the low-load fourth processing to be assigned to the pixel processing section.

15 In each of the image generation system, program, and information storage medium, the predetermined processing may be processing of texture coordinates calculation.

This enables efficient texture calculation processing, whereby the processing load of environment mapping or the like can be reduced.

20 In each of the image generation system, program, and information storage medium,

the vertex processing section may perform the first processing which includes outputting data of a normal vector of a vertex; and

25 the pixel processing section may perform the second processing which includes calculating texture coordinates of a pixel by subjecting a normal vector of the pixel to coordinate transformation and calculating a pixel color by texture mapping using the texture coordinates of the pixel.

This allows the low-load first processing of the texture coordinate calculation

processing to be assigned to the vertex processing section and allows the high-load second processing to be assigned to the pixel processing section.

In each of the image generation system, program, and information storage medium,

5 the vertex processing section may perform the third processing which includes calculating texture coordinates of a vertex by subjecting a normal vector of the vertex to coordinate transformation; and

the pixel processing section may perform the fourth processing which includes calculating a pixel color by texture mapping using texture coordinates of a pixel.

10 This allows the high-load third processing of the texture coordinate calculation processing to be assigned to the vertex processing section and allows the low-load fourth processing to be assigned to the pixel processing section.

In each of the image generation system, program, and information storage medium, the predetermined processing may be lighting processing.

15 This enables efficient lighting processing, whereby a more realistic image can be generated.

In each of the image generation system, program, and information storage medium,

20 the vertex processing section may perform the first processing which includes outputting data of a normal vector of a vertex; and

the pixel processing section may perform the second processing which includes calculating light intensity of a pixel based on a normal vector of the pixel and an illumination model and calculating a pixel color based on the light intensity of the pixel.

25 This allows the low-load first processing of the lighting processing to be assigned to the vertex processing section and allows the high-load second processing to be assigned to the pixel processing section.

In each of the image generation system, program, and information storage

medium,

the vertex processing section may perform the third processing which includes calculating light intensity of a vertex based on a normal vector of the vertex and an illumination model; and

5 the pixel processing section may perform the fourth processing which includes calculating a pixel color based on light intensity of a pixel.

This allows the high-load third processing of the lighting processing to be assigned to the vertex processing section and allows the low-load fourth processing to be assigned to the pixel processing section.

10 In each of the image generation system, program, and information storage medium, the predetermined processing may be color conversion processing.

This enables efficient color conversion processing, whereby conversion processing such as gamma correction can be realized.

15 In each of the image generation system, program, and information storage medium,

the vertex processing section may perform the first processing which includes outputting data of a vertex position and a vertex color; and

the pixel processing section may perform the second processing which includes converting a pixel color using a conversion table or a conversion function.

20 This allows the low-load first processing of the color conversion processing to be assigned to the vertex processing section and allows the high-load second processing to be assigned to the pixel processing section.

In each of the image generation system, program, and information storage medium,

25 the vertex processing section may perform the third processing which includes converting a vertex color using a conversion table or a conversion function; and

the pixel processing section may perform the fourth processing which includes

outputting a pixel color calculated from the converted vertex color.

This allows the high-load third processing of the color conversion processing to be assigned to the vertex processing section and allows the low-load fourth processing to be assigned to the pixel processing section.

5           Embodiments of the invention will be further described below. Note that the embodiments described below do not in any way limit the scope of the invention laid out in the claims herein. In addition, not all of the elements of the embodiments described below should be taken as essential requirements of the invention.

10    1.    Configuration

FIG. 1 shows an example of a functional block diagram of an image generation system (game system) according to one embodiment of the invention. Note that the image generation system according to this embodiment may have a configuration in which some of the elements (sections) shown in FIG. 1 are omitted.

15           An operation section 160 allows a player to input operation data. The function of the operation section 160 may be implemented by a lever, a button, a steering wheel, a microphone, a touch panel display, a casing, or the like. A storage section 170 functions as a work area for a processing section 100, a communication section 196, and the like. The function of the storage section 170 may be implemented by a RAM (VRAM) or the  
20 like.

An information storage medium 180 (computer-readable medium) stores a program, data, and the like. The function of the information storage medium 180 may be implemented by an optical disk (CD or DVD), a magneto-optical disk (MO), a hard disk, a memory (ROM), or the like. The processing section 100 performs various types of  
25 processing according to this embodiment based on a program (data) stored in the information storage medium 180. Specifically, a program for causing a computer to function as each section according to this embodiment (program for causing the computer

to execute processing of each section) is stored in the information storage medium 180.

A display section 190 outputs an image generated according to this embodiment. The function of the display section 190 may be implemented by a CRT, an LCD, a touch panel display, a head mount display (HMD), or the like. A sound output section 192  
5 outputs sound generated according to this embodiment. The function of the sound output section 192 may be implemented by a speaker, a headphone, or the like.

A portable information storage device 194 stores player's personal data, game save data, and the like. As the portable information storage device 194, a memory card, a portable game device, and the like can be given. The communication section 196  
10 performs various types of control for communicating with the outside (e.g. host device or another image generation system). The function of the communication section 196 may be implemented by hardware such as a processor or a communication ASIC, a program, and the like.

The program (data) for causing a computer to function as each section according  
15 to this embodiment may be distributed to the information storage medium 180 (or storage section 170) from an information storage medium of a host device (server) through a network and the communication section 196. Use of the information storage medium of the host device (server) may also be included within the scope of the invention.

The processing section 100 (processor) performs processing such as game  
20 processing, image generation processing, or sound generation processing based on operation data from the operation section 160, a program, and the like. As the game processing, starting a game when game start conditions have been satisfied, proceeding with a game, disposing an object such as a character or a map, displaying an object, calculating game results, finishing a game when game end conditions have been satisfied,  
25 and the like can be given. The processing section 100 performs various types of processing using the storage section 170 (main storage section 172) as a work area. The function of the processing section 100 may be implemented by hardware such as a

processor (e.g. CPU or DSP) or an ASIC (e.g. gate array) and a program.

The processing section 100 includes an object space setting section 110, a movement/motion processing section 112, a virtual camera control section 114, a drawing section 120, and a sound generation section 130. Note that the processing section 100  
5 may have a configuration in which some of these sections are omitted.

The object space setting section 110 performs processing of positioning various objects (objects formed by a primitive surface such as a polygon, free-form surface, or subdivision surface) representing display objects such as a car, train, character, building, stadium, tree, pillar, wall, or map (topography) in an object space. Specifically, the  
10 object space setting section 110 determines the position and the rotational angle (synonymous with orientation or direction) of an object in a world coordinate system, and disposes the object at the determined position (X, Y, Z) and the determined rotational angle (rotational angles around X, Y, and Z axes). In more detail, model data of a moving object (car), a stationary object (building), and a background object (map and  
15 celestial sphere) is stored in a model data storage section 176 of the storage section 170. The object space setting section 110 sets (disposes) the object in the object space using the model data.

The movement/motion processing section 112 calculates the movement/motion (movement/motion simulation) of the object (e.g. car, character, train, or airplane).  
20 Specifically, the movement/motion processing section 112 causes the object (model object) to move in the object space or to make a motion (animation) based on the operation data input by the player using the operation section 160, a program (movement/motion algorithm), various types of data (motion data), and the like. In more detail, the movement/motion processing section 112 performs simulation processing of  
25 sequentially calculating movement information (position, rotational angle, speed, or acceleration) and motion information (position or rotational angle of each part object) on the object in frame (1/60 sec) units. The frame is a time unit for performing the object

movement/motion processing (simulation processing) and the image generation processing.

The virtual camera control section 114 controls a virtual camera (view point) for generating an image viewed from a given (arbitrary) view point in the object space. In more detail, the virtual camera control section 114 controls the position (X, Y, Z) or the rotational angle (rotational angles around X, Y, and Z axes) of the virtual camera (processing of controlling the view point position, the line-of-sight direction, or the angle of view).

For example, when imaging the object (e.g. character, ball, or car) from behind using the virtual camera, the virtual camera control section 114 controls the position or the rotational angle (orientation) of the virtual camera so that the virtual camera follows a change in the position or rotation of the object. In this case, the virtual camera control section 114 may control the virtual camera based on information such as the position, rotational angle, or speed of the object obtained by the movement/motion processing section 112. Or, the virtual camera control section 114 may rotate the virtual camera at a predetermined rotational angle or may move the virtual camera along a predetermined path. In this case, the virtual camera control section 114 controls the virtual camera based on virtual camera data for specifying the position (moving path) or rotational angle of the virtual camera. When a plurality of virtual cameras (view points) exist, the above-described control is performed for each virtual camera.

The drawing section 120 performs drawing processing based on the results of various types of processing (game processing) performed by the processing section 100 to generate an image, and outputs the image to the display section 190. When generating a three-dimensional game image, model data including vertex data (e.g. vertex position coordinates, texture coordinates, color data, normal vector, or alpha value) of each vertex of the model (object) is input, and vertex processing (shading using a vertex shader) is performed based on the vertex data included in the input model data. When performing

the vertex processing, vertex generation processing (tessellation, curved surface division, or polygon division) for dividing a polygon may be performed, if necessary.

The drawing section 120 performs geometric processing, hidden surface removal, alpha blending, and the like when drawing the object.

5           In geometric processing, the object is subjected to processing such as coordinate transformation, clipping, perspective projection transformation, or light source calculation. The model data (e.g. object's vertex position coordinates, texture coordinates, color data (luminance data), normal vector, or alpha value) after the geometric processing (after perspective transformation) is stored in the storage section  
10   170.

The drawing section 120 may perform hidden surface removal by a Z buffer method (depth comparison method or Z test) using a Z buffer (depth buffer) in which the Z value (depth information) of the drawing pixel is stored. Specifically, the drawing section 120 refers to the Z value stored in the Z buffer when drawing the drawing pixel  
15   corresponding to the primitive of the object. The drawing section 120 compares the Z value stored in the Z buffer with the Z value of the drawing pixel of the primitive. When the Z value of the drawing pixel is the Z value in front of the virtual camera (e.g. small Z value), the drawing section 120 draws the drawing pixel and updates the Z value stored in the Z buffer with a new Z value.

20           Alpha blending refers to translucent blending (e.g. normal alpha blending, additive alpha blending, or subtractive alpha blending) based on the alpha value (A value).

The alpha value is information which can be stored while being associated with each pixel (texel or dot), such as additional information other than the color information.  
25   The alpha value may be used as mask information, translucency (equivalent to transparency or opacity), bump information, or the like.

The drawing section 120 includes a vertex processing section 122 and a pixel

processing section 124.

The vertex processing section 122 performs vertex processing (per-vertex processing). In the vertex processing, geometric processing such as vertex movement processing, coordinate transformation (world coordinate transformation or camera coordinate transformation), clipping, or perspective transformation is performed according to a vertex processing program (vertex shader program or first shader program). The vertex data provided for the vertices forming the object is changed (updated or adjusted) based on the processing results. Rasterization (scan conversion) is performed based on the vertex data after the vertex processing, whereby the surface of the polygon (primitive) is associated with the pixels.

After rasterization, the pixel processing section 124 performs pixel processing (per-pixel processing). In the pixel processing (shading and fragment processing using a pixel shader), various types of processing such as reading the texture (texture mapping), setting/changing color data, translucent compositing, and anti-aliasing is performed according to a pixel processing program (pixel shader program or second shader program). The final drawing colors of the pixels forming the image are determined, and the drawing colors of the model subjected to perspective transformation are output (drawn) to a drawing buffer 174 (buffer which can store image information in pixel units; VRAM or rendering target). Specifically, the pixel processing involves per-pixel processing which sets or changes the image information (e.g. color, normal, luminance, and alpha value) in pixel units. This causes an image viewed from the virtual camera (given view point) to be generated in the object space.

The vertex processing and the pixel processing may be implemented by hardware which enables programmable polygon (primitive) drawing processing (i.e. programmable shader (vertex shader and pixel shader)) according to a shader program created using shading language. The programmable shader enables programmable per-vertex processing and per-pixel processing to increase the degrees of freedom of drawing

processing, thereby significantly improving the representation capability in comparison with fixed drawing processing using known hardware.

In this embodiment, when subjecting a first object which is distant from the virtual camera (viewpoint) (object belonging to first group) to predetermined processing, the vertex processing section 122 performs a first processing with a low processing load which makes up a first processing and a second processing which implement (execute or make up) the predetermined processing. The pixel processing section 124 performs the second processing with a high processing load. Or, when subjecting a first object which occupies a small area (drawing area or occupied area) on the screen to the predetermined processing, the vertex processing section 122 performs the first processing with a low processing load, and the pixel processing section 124 performs the second processing with a high processing load.

On the other hand, when subjecting a second object which is closer to the virtual camera (viewpoint) than the first object (object belonging to second group) to predetermined processing, the vertex processing section 122 performs a third processing with a high processing load which makes up a third processing and a fourth processing which implement (execute or make up) the predetermined processing, and the pixel processing section 124 performs the fourth processing with a low processing load. Or, when subjecting a second object which occupies a larger area (drawing area or occupied area) on the screen than that of the first object to the predetermined processing, the vertex processing section 122 performs the third processing with a high processing load, and the pixel processing section 124 performs the fourth processing with a low processing load.

The distance from the virtual camera may be a depth distance (Z value) or a linear distance. Or, when course data is set to the course in which the first and second objects move, the distance between the virtual camera and each of the first and second objects may be determined based on the course data. The area on the screen may be determined based on the minimum values and the maximum values of the X coordinates and the Y

coordinates of the projection points of the first and second objects (vertices of the objects) on the screen, or may be determined based on the area of a bounding box (bounding volume) set based on the minimum values and the maximum values, for example.

As examples of the predetermined processing, light scattering processing, processing of calculating the texture coordinates based on the normal vector (environment mapping), lighting processing, color (image information) conversion processing, and the like can be given. Note that the predetermined processing is not limited thereto. Various types of processing (shading processing) may be considered. Specifically, it suffices that the predetermined processing be processing of which the efficiency can be improved by assigning the processing to the vertex processing section 122 and the pixel processing section 124.

The sound generation section 130 performs sound processing based on the results of various types of processing performed by the processing section 100 to generate game sound such as background music (BGM), effect sound, or voice, and outputs the generated game sound to the sound output section 192.

The image generation system according to this embodiment may be a system dedicated to a single-player mode in which only one player can play a game, or may be a system provided with a multi-player mode in which two or more players can play a game. When two or more players play a game, game images and game sound provided to the players may be generated using one terminal, or may be generated by distributed processing using two or more terminals (game devices or portable telephones) connected through a network (transmission line or communication line), for example.

## 2. Method according to this embodiment

### 2.1 Vertex processing section and pixel processing section

FIG. 2 shows a configuration example of the vertex processing section 122 and the pixel processing section 124. The vertex processing section 122 (vertex shader) may be

implemented by hardware such as a vector calculation unit and software such as a vertex processing program (vertex shader program), for example. The pixel processing section 124 (pixel shader) may be implemented by hardware such as a vector calculation unit and software such as a pixel processing program (pixel shader program), for example. The  
5 vector calculation units assigned to the vertex processing section 122 and the pixel processing section 124 may be fixed, or assignment of a plurality of vector calculation units to the vertex processing section 122 and the pixel processing section 124 may be dynamically changed.

The vertex processing section 122 includes a coordinate transformation section 10,  
10 a lighting processing section 12, and a texture coordinate calculation section 14.

The coordinate transformation section 10 transforms the coordinates into the world coordinate system or transforms the coordinates into the view coordinate system, for example. The position of the vertex of the object (model) on the screen can be determined by the coordinate transformation section 10. The coordinate transformation  
15 section 10 may also perform coordinate transformation of the normal vector or the like in addition to the position coordinate transformation.

The lighting processing section 12 performs lighting processing (light source calculation) based on the normal vector of the object and an illumination model. The lighting processing is performed using the attribute parameter of the light source (color,  
20 brightness, and type of the light source), the parameter of the normal vector, the parameter (color and material) of the material for the object, and the like. As examples of the illumination model, various models can be given, such as a Lambertian illumination model taking only ambient light and diffused light into consideration, a Phong illumination model taking specular light into consideration in addition to ambient  
25 light and diffused light, and a Blinn illumination model.

The texture coordinate calculation section 14 performs texture coordinate calculation (calculation and acquisition) processing. In more detail, the texture

coordinate calculation section 14 subjects the normal vector of the vertex to coordinate transformation to calculate the texture coordinates of the vertex, for example.

A rasterization processing section 123 performs rasterization (scan line conversion) processing. In more detail, processed vertex data is input to the rasterization processing section 123 from the vertex processing section 122. The rasterization processing section 123 generates the pixels forming the polygon based on the processed vertex data. In this case, various parameters included in the vertex data such as the vertex position, the vertex color, the vertex texture coordinates, and the vertex normal vector are interpolated (e.g. linear interpolation), and the pixel position, the pixel color, the pixel texture coordinates, and the pixel normal vector are calculated.

The pixel processing section 124 includes a texture mapping section 20 and a pixel processing section 22. The texture mapping section 20 performs texture mapping (sampling). The term “texture mapping” refers to processing for mapping (sampling) a texture (texel value) stored in a texture storage section 178 of the storage section 170. In more detail, the texture mapping section 20 reads the texture (surface properties such as color and alpha value) data from the texture storage section 178 using the pixel texture coordinates and maps the texture.

The pixel processing section 22 subjects the pixel data to various types of processing. The color of the pixel (fragment) is determined by the above processing. After the processing (pixel shader), the pixel processing section 22 performs a scissor test, an alpha test, a depth test, a stencil test, or the like to determine whether or not the pixel (fragment) is displayed. After the pixel processing section 22 has determined that the pixel is displayed, the pixel data is further processed (fog, translucent compositing, and anti-aliasing), and the processed pixel data is written into a frame buffer.

25

## 2.2 Assignment of processing to vertex processing section and pixel processing

section

In this embodiment, when performing predetermined processing, assignment (distribution) of the processing to the vertex processing section 122 and the pixel processing section 124 is changed for each object (each object group), thereby improving the efficiency of the processing.

Specifically, the pixel processing section 124 is caused to perform processing with a high load when processing the first object, and the vertex processing section 122 is caused to perform processing with a high load when processing the second object.

In more detail, when processing the first object distant from the virtual camera (viewpoint), the vertex processing section 122 is caused to perform a first processing with a low load, and the pixel processing section 124 is caused to perform a second processing with a high load. The predetermined processing (e.g. light scattering, texture coordinate calculation, lighting, or color conversion) is implemented by the first processing and the second processing. The first object may be an object of which the area on the screen is smaller than that of the second object.

On the other hand, when processing the second object which is closer to the virtual camera than the first object, the vertex processing section 122 is caused to perform the third processing with a high load, and the pixel processing section 124 is caused to perform the fourth processing with a low load. The above predetermined processing is implemented by the third processing and the fourth processing. The second object may be an object of which the area on the screen is larger than that of the first object. The first and second objects may be a moving object (e.g. car, train, airplane, ship, or character) or a stationary object (e.g. building). The first and second objects may be a background object (e.g. distant view object such as mountain or map object such as a road or ground).

In FIG. 3A, a distance DS1 from a virtual camera VC to an object OB1 (representative point) is long, and a distance DS2 from the virtual camera VC to a object OB2 (representative point) is short, for example. In FIG. 3B, the area of the object OB1

on the screen is small, and the area of the object OB2 on the screen is large.

The areas of the objects OB1 and OB2 on the screen may be determined from the size of bounding boxes BD1 and BD2 (regions involving the objects OB1 and OB2).

For example, minimum values XMIN1 and YMIN1 and maximum values  
5 XMAX1 and YMAX1 of the X and Y coordinates of the vertices of the object OB1 on the screen are determined. The region formed by vertices VX11 (XMIN1, YMIN1), VX12 (XMIN1, YMAX1), VX13 (XMAX1, YMAX1), and VX14 (XMAX1, YMIN1) may be defined as the bounding box BD1. The bounding box BD1 may be enlarged to a small extent in the vertical and horizontal directions.

10 Minimum values XMIN2 and YMIN2 and maximum values XMAX2 and YMAX2 of the X and Y coordinates of the vertices of the object OB2 on the screen are determined. The region formed by vertices VX21 (XMIN2, YMIN2), VX22 (XMIN2, YMAX2), VX23 (XMAX2, YMAX2), and VX24 (XMAX2, YMIN2) may be defined as the bounding box BD2. The bounding box BD2 may be enlarged to a small extent in the  
15 vertical and horizontal directions.

The areas of the objects OB1 and OB2 on the screen may be determined based on the size of the bounding boxes BD1 and BD2 thus determined. The areas of the objects OB1 and OB2 on the screen may be determined based on the minimum values and the maximum values of the X and Y coordinates of the vertices of the objects OB1 and OB2  
20 on the screen.

In the case of the object OB2 of which the distance DS2 from the virtual camera VC is short and which occupies a large area on the screen, as shown in FIGS. 3A and 3B, a polygon PL2 forming the object OB2 has a large size on the screen, as shown in FIG. 4A. In FIG. 4A, the number of vertices VE1 to VE4 of the polygon PL2 is four, and the  
25 number of pixels PX1 to PX25 is 25, for example. Therefore, if the pixel processing section 124 performs the main portion of the predetermined processing, the processing load may be increased due to an increase in the number of processing operations.

In this embodiment, when processing the object OB2 of which the distance DS2 from the virtual camera VC is short, the vertex processing section 122 performs the main processing (third processing) with a high processing load instead of the pixel processing section 124. This allows the number of processing operations of the main processing to be reduced to four in the example shown in FIG. 4A, whereby the processing load can be significantly reduced in comparison with the case where the pixel processing section 124 performs the main processing (i.e. the number of processing operations is 25).

In the case of the object OB1 of which the distance DS1 from the virtual camera VC is long and which occupies a small area on the screen, as shown in FIGS. 3A and 3B, a polygon PL1 forming the object OB1 has a small size on the screen, as shown in FIGS. 4B and 4C. In FIG. 4B, the number of vertices VE1 to VE4 of the polygon PL1 is four, and the number of pixels is two, for example. In FIG. 4C, the number of vertices VE1 to VE4 is four, and the number of pixels is one. Therefore, if the vertex processing section 122 performs the main portion of the predetermined processing, the processing load may be increased due to an increase in the number of processing operations.

In this embodiment, when processing the object OB1 of which the distance DS1 from the virtual camera VC is long, the pixel processing section 124 performs the main processing (second processing) with a high processing load instead of the vertex processing section 122. This allows the number of processing operations of the main processing to be reduced to two in the example shown in FIG. 4B and reduced to one in the example shown in FIG. 4C. Therefore, the processing load can be significantly reduced in comparison with the case where the vertex processing section 122 performs the main processing (i.e. the number of processing operations is four). The effect of reducing the processing load increases as the number of vertices of the object becomes larger.

A specific method of implementing assignment of processing to the vertex processing section 122 and the pixel processing section 124 is described below. FIG. 5A

shows a description example of a program (source program) for an object of which the distance from the virtual camera is long or occupies a small area on the screen (hereinafter called “long-distance object”), and FIG. 5B shows a description example of a program for an object of which the distance from the virtual camera is short or occupies a large area on the screen (hereinafter called “short-distance object”).

The program for the long-distance object shown in FIG. 5A includes a vertex processing program (vertex shader program) and a pixel processing program (pixel shader program). The function of the vertex processing section 122 shown in FIG. 2 is implemented by hardware such as a vector calculation unit and the vertex processing program executed by the hardware. The function of the pixel processing section 124 is implemented by hardware such as a vector calculation unit and the pixel processing program executed by the hardware.

The vertex processing program shown in FIG. 5A includes a program for a first processing with a low processing load which makes up a first processing and a second processing which implement predetermined processing, and the pixel processing program includes a program for the second processing with a high processing load. As shown in FIG. 5A, a large number of functions and variables are described in the program for the second processing in comparison with the program for the first processing, so that the amount of description (number of steps) is large. Therefore, the processing load when the pixel processing section 124 executes the program for the second processing is greater than the processing load when the vertex processing section 122 executes the program for the first processing.

The program for the short-distance object shown in FIG. 5B includes a vertex processing program (vertex shader program) and a pixel processing program (pixel shader program).

The vertex processing program shown in FIG. 5B includes a program for a third processing with a high processing load which makes up a third processing and a fourth

processing which implement predetermined processing, and the pixel processing program includes a program for the fourth processing with a low processing load. As shown in FIG. 5B, a large number of functions and variables are described in the program for the third processing in comparison with the program for the fourth processing, so that the amount of description (number of steps) is large. Therefore, the processing load when the vertex processing section 122 executes the program for the third processing is greater than the processing load when the pixel processing section 124 executes the program for the fourth processing.

### 2.3 Light scattering processing

The predetermined processing implemented by the first processing and the second processing or the third processing and the fourth processing is described below. A case where the predetermined processing is light scattering processing (fog processing in a broad sense) is described first.

Light scattering is a phenomenon in which light is scattered due to atmospheric density fluctuations, particles in air, and the like. For example, sunlight is made up of light of seven colors. In the case of light scattering due to small particles, light of a color with a short wavelength is easily scattered, and light of a color with a long wavelength is scattered to only a small extent. In more detail, light of a color close to violet is easily scattered, and light of a color close to red is scattered to only a small extent.

The daytime sky looks blue because blue light contained in sunlight is scattered due to particles in the air to cover the sky and enters the observer's eyes. On the other hand, the sunset sky looks red because light from the setting sun travels a long distance in the air so that red light scattered to only a small extent due to particles in the air enters the observer's eyes.

In this embodiment, the light scattering phenomenon is represented by out-scattering and in-scattering models, as shown in FIG. 6A.

The out-scattering model is a model which represents a situation in which light is absorbed by air or scattered by particles to withdraw from the field of view (field of view of the virtual camera VC) so that the light attenuates. The in-scattering model is a model which represents a situation in which light from the sun LS (light source in a broad sense) enters the field of view so that the light is added.

In more detail, the light scattering model according to this embodiment is shown by the following expressions.

$$L = L_{out} + L_{in} \quad \dots (1)$$

10

$$L_{out} = L_0 \times f_{ex} \quad \dots (2)$$

$$L_{in} = INT \times (1 - f_{ex}) \quad \dots (3)$$

15

$$f_{ex} = e^{-(\beta R + \beta M)S} \quad \dots (4)$$

$$INT = \frac{\beta R(\theta) + \beta M(\theta)}{\beta R + \beta M} E \quad \dots (5)$$

$$\beta R(\theta) = \frac{3}{16\pi} \beta R (1 + \cos^2 \theta) \quad \dots (6)$$

20

$$\beta M(\theta) = \frac{1}{4\pi} \beta M \frac{(1-g)^2}{(1+g^2-2g\cos\theta)^{\frac{3}{2}}} (1+\cos^2\theta) \quad \dots (7)$$

In these expressions,  $L_{out}$  indicates the color (color component) formed by out-scattering, and  $L_{in}$  indicates the color (color component) formed by in-scattering.

5  $L_0$  indicates the input color. In more detail,  $L_0$  indicates the color of light (reflected light) from the vertex VE of the object OB (long-distance object OB1 or short-distance object OB2), as shown in FIG. 6A, for example.  $I_{NT}$  is a function indicating the intensity of light by in-scattering, and  $f_{ex}$  is a function indicating extinction.

$S$  is a parameter of the distance between the virtual camera VC (viewpoint) and  
10 the vertex VE;  $\theta$  is a parameter of the angle formed by the line-of-sight direction of the virtual camera VC and the direction of light from the light source LS;  $E$  is a parameter of the intensity of light from the sun LS;  $BR$  is a Rayleigh coefficient which is a parameter indicating the density of air;  $BM$  is an MIE coefficient which is a parameter of the density of dust in air; and  $g$  is a parameter indicating the degree to which dust in air scatters light.

15 In this embodiment, an object (vertex) positioned at a specific distance  $SS$  from the virtual camera VC (viewpoint) is not subjected to the light scattering processing. For example, a sky picture is drawn on a celestial sphere object OBS. The sky picture is usually a picture drawn by a CG designer taking light scattering into consideration. Therefore, if the sky portion of the celestial sphere object OBS is subjected to the light  
20 scattering processing according to this embodiment, a situation occurs in which the light scattering effects are provided twice.

On the other hand, occurrence of such a situation can be prevented by not  
subjecting the object positioned at the specific distance  $SS$  from the virtual camera VC to the light scattering processing, as shown in FIG. 6B, whereby the quality of the generated  
25 image can be improved.

The light scattering processing according to this embodiment is described below using flowcharts shown in FIGS. 7 and 8.

FIG. 7 is a flowchart of light scattering processing (predetermined processing in a broad sense) performed for the long-distance object OB1. The vertex processing section 122 performs vertex processing (step S1). The vertex processing is a first processing with a low load, as shown in FIG. 5A. The vertex processing is performed for each vertex forming the long-distance object OB1.

In the vertex processing, the position of the vertex in the view (camera) coordinate system is calculated, and the data of the calculated vertex position is output (step S2). For example, the data is output to a vertex buffer (output register) as vertex data. The distance S between the virtual camera and the vertex is calculated based on the calculated vertex position, and the data of the calculated distance is output (step S3). The vertex processing is thus completed.

After the vertex processing has been completed, the rasterization processing section 123 performs rasterization processing (step S4). In the rasterization processing, interpolation calculations of the vertex position, the vertex color, and the like are performed. The distance between the virtual camera and the vertex calculated in the step S3 is also subjected to interpolation calculation.

After the rasterization processing has been completed, the pixel processing section 124 performs pixel processing (step S5). The pixel processing is a second processing with a high load, as shown in FIG. 5A. The pixel processing is performed for each pixel (fragment) forming the screen.

In the pixel processing, the angle  $\theta$  formed by the line-of-sight direction of the virtual camera and the direction of light from the sun is calculated (step S6). Note that  $\cos\theta$  may be directly calculated instead of the angle  $\theta$ . The line-of-sight direction of the virtual camera may be calculated based on the position of the virtual camera and the position of the point obtained by interpolating the vertex position by the rasterization

processing in the step S4.

The  $\beta R(\theta)$  and  $BM(\theta)$  shown in the expressions (6) and (7) are calculated based on  $\theta$  ( $\cos\theta$ ) obtained in the step S6 (steps S7 and S8). The intensity INT of light by in-scattering shown by the expression (5) is calculated based on the calculated  $\beta R(\theta)$  and  
5  $BM(\theta)$  (step S9).

Based on the distance S,  $f_{ex}$  shown in the expression (4) is then calculated (step S10). The distance S may be calculated based on the position of the virtual camera and the position of the point obtained by interpolating the vertex position by the rasterization processing in the step S4

10 The color  $L_{in}$  of light by in-scattering shown in the expression (3) is calculated (step S11). The color  $L_{out}$  of light by out-scattering shown in the expression (2) is also calculated (step S12). The colors  $L_{out}$  and  $L_{in}$  are added as shown by the expression (1), and the final color L (pixel color) of light subjected to scattering is calculated (step S13).

FIG. 8 is a flowchart of light scattering processing performed for the  
15 short-distance object OB2. The vertex processing section 122 performs the vertex processing (step S21). The vertex processing is a third processing with a high load, as shown in FIG. 5B. The vertex processing is performed for each vertex forming the short-distance object OB2.

In the vertex processing, the position of the vertex in the view coordinate system  
20 is calculated, and the data of the calculated vertex position is output (step S22). The distance S between the virtual camera and the vertex is calculated based on the calculated vertex position, and the data of the calculated distance is output (step S23).

$f_{ex}$  shown in the expression (4) is calculated based on the distance S calculated in the step S23 (step S24). The color  $L_{out}$  (vertex color) of light by out-scattering shown  
25 by the expression (2) is also calculated (step S25).

The angle  $\theta$  formed by the line-of-sight direction of the virtual camera and the direction of light from the sun is calculated (step S26). Note that  $\cos\theta$  may be directly

calculated instead of the angle  $\theta$ . The line-of-sight direction of the virtual camera may be calculated based on the position of the virtual camera and the vertex position calculated in the step S22.

$\beta R(\theta)$  and  $BM(\theta)$  shown in the expressions (6) and (7) are calculated based on  $\theta$  (cos $\theta$ ) obtained in the step S26 (steps S27 and S28). The intensity INT of light by in-scattering shown in the expression (5) is calculated based on the calculated  $\beta R(\theta)$  and  $BM(\theta)$  (step S29). The color Lin (vertex color) of light by in-scattering shown in the expression (3) is calculated (step S30). The vertex processing is thus completed.

After the vertex processing has been completed, the rasterization processing section 123 performs rasterization processing (step S31). In the rasterization processing, the color Lout calculated in the step S25 and the color Lin calculated in the step S30 are subjected to interpolation calculations.

After the rasterization processing has been completed, the pixel processing section 124 performs pixel processing (step S32). The pixel processing is a fourth processing with a low load, as shown in FIG. 5B. The pixel processing is performed for each pixel (fragment) forming the screen.

In the pixel processing, the color Lout (pixel color) of light by out-scattering and the color Lin (pixel color) of light by in-scattering are added, and the final color L (pixel color) of light subjected to scattering is calculated (step S33). The colors Lout and Lin subjected to interpolation calculations in the rasterization processing in the step S31 are used.

As shown in FIG. 7, when subjecting the long-distance object to the light scattering processing, the load of the first processing (i.e. vertex processing) (steps S2 and S3) is low, and the load of the second processing (i.e. pixel processing) (steps S6 to S13) is high. When subjecting the long-distance object to the light scattering processing, the number of pixel processing operations is usually smaller than the number of vertex processing operations, as shown in FIGS. 4B and 4C. Therefore, the entire processing

load can be reduced by the method shown in FIG. 7.

As shown in FIG. 8, when subjecting the short-distance object to the light scattering processing, the load of the third processing (i.e. vertex processing) (steps S22 to S30) is high, and the load of the fourth processing (i.e. pixel processing) (step S33) is low. When subjecting the short-distance object to the light scattering processing, the number of vertex processing operations is usually smaller than the number of pixel processing operations, as shown in FIG. 4A. Therefore, the entire processing load can be reduced by the method shown in FIG. 8.

#### 2.4 Texture coordinate calculation processing

A case where the predetermined processing is texture coordinate calculation (derivation) processing is described below. In environment mapping such as sphere environment mapping, the texture coordinates are calculated, and a texture is mapped (sampled) using the calculated texture coordinates to represent reflection of the surrounding environment on the object. The method according to this embodiment may be applied to such texture coordinate calculation processing.

In FIG. 9,  $N(NX, NY, NZ)$  indicates the normal vector of the object OB. In this case, the normal vector  $N(NX, NY, NZ)$  is subjected to coordinate transformation to determine the normal vector  $NV(NXV, NYV, NZV)$  after the coordinate transformation. As the coordinate transformation, transformation into the view coordinate system using the view matrix of the virtual camera VC and the like can be given. Note that the coordinate transformation according to this embodiment is not limited to transformation into the view coordinate system.

The texture coordinates TX and TY (U and V coordinates) are calculated based on the coordinates NXV and NYV of the normal vector NV after the coordinate transformation. An environment texture is read using the calculated texture coordinates TX and TY, and mapped onto the object OB. This allows a realistic image to be

generated in which the surrounding environment is reflected on the object OB. The environment mapping to which the texture coordinate calculation method according to this embodiment may be applied is not limited to sphere environment mapping, and may be another environment mapping method. The texture coordinate calculation method according to this embodiment may be applied to mapping other than environment mapping.

The texture coordinate calculation processing according to this embodiment is described below using flowcharts shown in FIGS. 10 and 11.

FIG. 10 shows a flowchart of the texture coordinate calculation processing (predetermined processing in a broad sense) performed for the long-distance object OB1.

The vertex processing section 122 performs the vertex processing (step S41). The vertex processing is a first processing with a low load, as shown in FIG. 5A. In the vertex processing, the data of the vertex normal vector  $N(NX, NY, NZ)$  is output (step S42).

After the vertex processing has been completed, the rasterization processing section 123 performs rasterization processing (step S43). In the rasterization processing, interpolation calculations of the vertex position, the vertex color, and the like are performed. The vertex normal vector calculated in the step S42 is also subjected to interpolation calculation (linear interpolation).

After the rasterization processing has been completed, the pixel processing section 124 performs pixel processing (step S44). The pixel processing is a second processing with a high load, as shown in FIG. 5A.

In the pixel processing, the normal vector  $N(NX, NY, NZ)$  of the pixel (fragment) is subjected to coordinate transformation using the matrix (step S45). For example, the normal vector  $N(NX, NY, NZ)$  is subjected to coordinate transformation into the view coordinate system to determine the normal vector  $NV(NXV, NYV, NZV)$  of the pixel after the coordinate transformation. The texture coordinates TX and TY of the pixel are

calculated based on the coordinates NXV and NYV of the normal vector NV (step S46). In more detail, the texture coordinates TX and TY are calculated according to the following expressions (8) and (9).

5             $TX = (NXV + 1.0) / 2$             (8)

$TY = (NYV + 1.0) / 2$             (9)

The calculations shown by the expressions (8) and (9) are performed because the range of the texture coordinates TX and TY is 0.0 to 1.0 and the range of the coordinates  
10    NTX and NTY is -1.0 to 1.0.

Texture mapping (texture sampling) is performed based on the calculated texture coordinates of the pixel, and the pixel color is calculated (step S47). In more detail, the final pixel color COLOUT is calculated according to the following expression (10).

15             $COLOUT = CTEX(TX, TY) \times COL$             (10)

In the expression (10), CTEX(TX, TY) is the color read from the texture storage section 178 based on the texture coordinates, and COL is the original color (underlayer color) of the long-distance object OB1.

20            FIG. 11 shows a flowchart of the texture coordinate calculation processing performed for the short-distance object OB2.

The vertex processing section 122 performs vertex processing (step S51). The vertex processing is a third processing with a high load, as shown in FIG. 5B.

In the vertex processing, the vertex normal vector N(NX, NY, NZ) is subjected to  
25    coordinate transformation using the matrix (step S52). For example, the normal vector N(NX, NY, NZ) is subjected to coordinate transformation into the view coordinate system to determine the vertex normal vector NV(NXV, NYV, NZV) after the coordinate

transformation. The vertex texture coordinates TX and TY are calculated based on the coordinates NXV and NYV of the normal vector NV (step S53). In more detail, the texture coordinates TX and TY are calculated according to the above expressions (8) and (9). The vertex processing is thus completed.

5           After the vertex processing has been completed, the rasterization processing section 123 performs rasterization processing (step S54). In the rasterization processing, interpolation calculations of the vertex position, the vertex color, and the like are performed. The vertex texture coordinates calculated in the step S53 is also subjected to interpolation calculation (linear interpolation).

10           After the rasterization processing has been completed, the pixel processing section 124 performs pixel processing (step S55). The pixel processing is a fourth processing with a low load, as shown in FIG. 5B. Specifically, texture mapping (texture sampling) is performed based on the texture coordinates of the pixel, and the pixel color CLOUT is calculated according to the above expression (10) (step S56).

15           As shown in FIG. 10, when subjecting the long-distance object to the texture coordinate calculation processing, the load of the first processing (i.e. vertex processing) (step S42) is low, and the load of the second processing (i.e. pixel processing) (steps S45 to S47) is high. When subjecting the long-distance object to the texture coordinate calculation processing, since the number of pixel processing operations is usually smaller  
20 than the number of vertex processing operations, as shown in FIGS 4B and 4C, the entire processing load can be reduced.

          As shown in FIG. 11, when subjecting the short-distance object to the texture coordinate calculation processing, the load of the third processing (i.e. vertex processing) (steps S52 and S53) is high, and the load of the fourth processing (i.e. pixel processing)  
25 (step S56) is low. When subjecting the short-distance object to the texture coordinate calculation processing, since the number of vertex processing operations is usually smaller than the number of pixel processing operations, as shown in FIG. 4A, the entire

processing load can be reduced.

## 2.5 Lighting processing

A case where the predetermined processing is lighting (light source calculation) processing is described below. As a mathematical model for simulating a lighting phenomenon in the real world, various illumination models are used in this type of image generation system. As a typical illumination model when the light source is parallel light, a Lambertian illumination model shown in FIG. 12A and the following expressions (11), (12), and (13) is known.

10

$$I1 = Ka \times Ia + Kd \times Id \times (N1 \cdot L) \quad (11)$$

$$I2 = Ka \times Ia + Kd \times Id \times (N2 \cdot L) \quad (12)$$

$$I3 = Ka \times Ia + Kd \times Id \times (N3 \cdot L) \quad (13)$$

15

$I1$ ,  $I2$ , and  $I3$  are the intensities of light at the vertices  $VE1$ ,  $VE2$ , and  $VE3$ ,  $Ka$  is the ambient light reflection coefficient, and  $Ia$  is the intensity of ambient light.  $Kd$  is the diffuse reflection coefficient for light from the light source  $LS$ , and  $Id$  is the intensity of light from the light source  $LS$ .  $N1$ ,  $N2$ , and  $N3$  are the normal vectors of the vertices  $VE1$ ,  $VE2$ , and  $VE3$ , and  $L$  is the direction vector of light from the light source  $LS$ .

20

In FIG. 12B, the normal vector  $N2$  of the vertex  $VE2$  and the normal vector  $N3$  of the vertex  $VE3$  is subjected to interpolation processing (linear interpolation) to determine the normal vector  $NJ$  of each pixel. The interpolation processing of the normal vectors is performed by the rasterization processing section 123 shown in FIG. 2. The light intensity  $IJ$  at each pixel is calculated based on the determined normal vector  $NJ$  according to the following expression (14).

25

$$IJ = Ka \times Ia + Kd \times Id \times (NJ \cdot L) \quad (14)$$

The method according to this embodiment may be applied to the lighting processing using the above-described illumination model. The illumination model to which the method according to this embodiment may be applied is not limited to the Lambertian illumination model, and may be a Phong illumination model taking specular light into consideration, a Blinn illumination model, or another illumination model.

The lighting processing according to this embodiment is described below using flowcharts shown in FIGS. 13 and 14.

FIG. 13 shows a flowchart of the lighting processing (predetermined processing in a broad sense) performed for the long-distance object OB1.

The vertex processing section 122 performs the vertex processing (step S61). The vertex processing is a first processing with a low load, as shown in FIG. 5A. In the vertex processing, the data of the normal vector  $N(NX, NY, NZ)$  of the vertex is output (step S62).

After the vertex processing has been completed, the rasterization processing section 123 performs rasterization processing (step S63). In the rasterization processing, interpolation calculations of the vertex position, the vertex color, and the like are performed. The vertex normal vector calculated in the step S62 is also subjected to interpolation calculation (linear interpolation).

After the rasterization processing has been completed, the pixel processing section 124 performs pixel processing (step S64). The pixel processing is a second processing with a high load, as shown in FIG. 5A.

In the pixel processing, the light intensity  $I$  of the pixel is calculated based on the normal vector  $N(NX, NY, NZ)$  of the pixel (fragment) and the illumination model shown by the above expression (14) (step S65). The pixel color CLOUT is calculated based on the calculated light intensity  $I$  according to the following expression (15) (step S66).

$$\text{CLOUT} = I \times \text{COL} \quad (15)$$

COL is the original color (underlayer color) of the long-distance object OB1.

FIG. 14 shows a flowchart of the lighting processing performed for the  
5 short-distance object OB2.

The vertex processing section 122 performs vertex processing (step S71). The vertex processing is a third processing with a high load, as shown in FIG. 5B.

In the vertex processing, the light intensity  $I$  of the vertex is calculated based on the normal vector  $N(NX, NY, NZ)$  of the vertex and the illumination model shown by the  
10 above expressions (11), (12), and (13), and the data of the light intensity is output (step S72). The vertex processing is thus completed.

After the vertex processing has been completed, the rasterization processing section 123 performs rasterization processing (step S73). In the rasterization processing, interpolation calculations of the vertex position, the vertex color, and the like are  
15 performed. The light intensity calculated in the step S72 is also subjected to interpolation calculation (linear interpolation).

After the rasterization processing has been completed, the pixel processing section 124 performs pixel processing (step S74). The pixel processing is a fourth processing with a low load, as shown in FIG. 5B. Specifically, the pixel color is  
20 calculated based on the light intensity of the pixel according to the above expression (15) (step S75).

As shown in FIG. 13, when subjecting the long-distance object to the lighting processing, the load of the first processing (i.e. vertex processing) (step S62) is low, and the load of the second processing (i.e. pixel processing) (steps S65 and S66) is high.  
25 When subjecting the long-distance object to the lighting processing, since the number of pixel processing operations is usually smaller than the number of vertex processing operations, as shown in FIGS 4B and 4C, the entire processing load can be reduced.

As shown in FIG. 14, when subjecting the short-distance object to the lighting processing, the load of the third processing (i.e. vertex processing) (step S72) is high, and the load of the fourth processing (i.e. pixel processing) (step S75) is low. When subjecting the short-distance object to the lighting processing, since the number of vertex processing operations is usually smaller than the number of pixel processing operations, as shown in FIG. 4A, the entire processing load can be reduced.

## 2.6 Color conversion processing

A case where the predetermined processing is color conversion processing is described below. In this type of image generation system, it is desirable to subject an image to conversion called gamma correction in order to correct the nonlinear characteristics of the display section (monitor). FIG. 15A shows an example of the gamma correction conversion characteristics. The color conversion processing for gamma correction or the like is generally implemented by post-filter processing. This embodiment employs a method of performing color conversion processing for gamma correction or the like during rendering. Note that the color conversion processing to which the method according to this embodiment is applied is not limited to gamma correction shown in FIG. 15A. The method according to this embodiment may be applied to various types of conversion processing as shown in FIGS. 15B and 15C. FIG. 15B shows an example of posterization conversion processing, and FIG. 15C shows an example of negative/positive conversion processing.

The color conversion processing according to this embodiment is described below using flowcharts shown in FIGS. 16 and 17.

FIG. 16 shows a flowchart of the color conversion processing (predetermined processing in a broad sense) performed for the long-distance object OB1.

The vertex processing section 122 performs vertex processing (step S81). The vertex processing is a first processing with a low load, as shown in FIG. 5A. In the

vertex processing, the data of the vertex position and the vertex color is output (step S82).

After the vertex processing has been completed, the rasterization processing section 123 performs rasterization processing (step S83). In the rasterization processing, interpolation calculations of the vertex position, the vertex color, and the like are performed.

After the rasterization processing has been completed, the pixel processing section 124 performs pixel processing (step S84). The pixel processing is a second processing with a high load, as shown in FIG. 5A.

In the pixel processing, a conversion table (or conversion function) for the color conversion processing is read (step S85). The pixel color at the pixel position is converted using the conversion table (or conversion function), and the pixel color CLOUT after conversion is calculated according to the following expression (16) (step S86).

$$15 \quad \text{CLOUT} = \text{TABLE}(\text{COL}) \quad (16)$$

COL is the original color before conversion, and TABLE(COL) is the color obtained by conversion using the conversion table.

FIG. 17 shows a flowchart of the color conversion processing performed for the short-distance object OB2.

The vertex processing section 122 performs vertex processing (step S91). The vertex processing is a third processing with a high load, as shown in FIG. 5B.

In the vertex processing, a conversion table (or conversion function) for the color conversion processing is read (step S92). The vertex color at the vertex position is converted using the conversion table (or conversion function), and the vertex color CLOUT after conversion is calculated according to the above expression (16) (step S93). The vertex processing is thus completed.

After the vertex processing has been completed, the rasterization processing section 123 performs rasterization processing (step S94). In the rasterization processing, interpolation calculations of the vertex position, the vertex color, and the like are performed.

5 After the rasterization processing has been completed, the pixel processing section 124 performs pixel processing (step S95). The pixel processing is a fourth processing with a low load, as shown in FIG. 5B. Specifically, the pixel color obtained by the interpolation processing of the vertex color is output (step S96).

As shown in FIG. 16, when subjecting the long-distance object to the color  
10 conversion processing, the load of the first processing (i.e. vertex processing) (step S82) is low, and the load of the second processing (i.e. pixel processing) (steps S85 and S86) is high. When subjecting the long-distance object to the color conversion processing, since the number of pixel processing operations is usually smaller than the number of vertex processing operations, as shown in FIGS 4B and 4C, the entire processing load can be  
15 reduced.

As shown in FIG. 17, when subjecting the short-distance object to the color  
conversion processing, the load of the third processing (i.e. vertex processing) (steps S92 and S93) is high, and the load of the fourth processing (i.e. pixel processing) (step S96) is low. When subjecting the short-distance object to the color conversion processing, since  
20 the number of vertex processing operations is usually smaller than the number of pixel processing operations, as shown in FIG. 4A, the entire processing load can be reduced.

### 3. Hardware configuration

FIG. 18 shows an example of a hardware configuration which can implement this  
25 embodiment. A main processor 900 operates based on a program stored in a DVD 982 (information storage medium; may be a CD), a program downloaded through a communication interface 990, a program stored in a ROM 950, or the like, and performs

game processing, image processing, sound processing, and the like. A coprocessor 902 assists the processing of the main processor 900, and performs matrix calculation (vector calculation) at high speed. In the case where matrix calculations are necessary for physical simulation to cause the object to move or make motion, a program which  
5 operates on the main processor 900 directs (requests) the coprocessor 902 to perform the processing.

A geometry processor 904 performs geometric processing such as a coordinate transformation, perspective transformation, light source calculation, or curved surface generation based on instructions from a program operating on the main processor 900,  
10 and performs a matrix calculation at high speed. A data decompression processor 906 decodes compressed image data or sound data, or accelerates the decode processing of the main processor 900. This enables a video image compressed according to the MPEG standard or the like to be displayed in an opening screen or a game screen.

A drawing processor 910 draws (renders) an object formed by a primitive plane  
15 such as a polygon or a curved surface. When drawing an object, the main processor 900 delivers drawing data to the drawing processor 910 by utilizing a DMA controller 970, and transfers a texture to a texture storage section 924, if necessary. The drawing processor 910 draws an object in a frame buffer 922 based on the drawing data and the texture while performing hidden surface removal utilizing a Z buffer or the like. The  
20 drawing processor 910 also performs alpha blending (translucent processing), depth queuing, MIP mapping, fog processing, bilinear filtering, trilinear filtering, anti-aliasing, shading, and the like. When a programmable shader such as a vertex shader or a pixel shader is mounted, the programmable shader creates or changes (updates) vertex data or determines the color of a pixel (or fragment) according to a shader program. When the  
25 image of one frame has been written into the frame buffer 922, the image is displayed on a display 912.

A sound processor 930 includes a multi-channel ADPCM sound source or the like,

generates game sound such as background music (BGM), effect sound, or voice, and outputs the generated game sound through a speaker 932. Data from a game controller 942 or a memory card 944 is input through a serial interface 940.

A system program or the like is stored in the ROM 950. In an arcade game  
5 system, the ROM 950 functions as an information storage medium, and various programs are stored in the ROM 950. A hard disk may be used instead of the ROM 950. A RAM 960 functions as a work area for various processors. The DMA controller 970 controls DMA transfer between the processor and the memory. A DVD drive 980 (may be a CD  
10 drive) accesses a DVD 982 (may be a CD) in which a program, image data, sound data, and the like are stored. The communication interface 990 transfers data with the outside through a network (communication line or high-speed serial bus).

The processing of each section (each means) according to this embodiment may be implemented by only hardware, or may be implemented by a program stored in the information storage medium or a program distributed through the communication  
15 interface. Or, the processing of each section may be implemented by hardware and a program.

When implementing the processing of each section according to this embodiment by hardware and a program, a program for causing the hardware (computer) to function as each section according to this embodiment is stored in the information storage medium.  
20 In more detail, the program directs each of the processors 902, 904, 906, 910, and 930 (hardware) to perform the processing, and transfers data to the processors, if necessary. The processors 902, 904, 906, 910, and 930 implement the processing of each section according to this embodiment based on the instructions and the transferred data.

Although only some embodiments of the invention have been described in detail  
25 above, those skilled in the art will readily appreciate that many modifications are possible in the embodiments without materially departing from the novel teachings and advantages of this invention. Accordingly, all such modifications are intended to be

included within the scope of the invention. Any term (e.g. polygon or light scattering processing/texture coordinate calculation processing/lighting processing/color conversion processing) cited with a different term (e.g. primitive plane or predetermined processing) having a broader meaning or the same meaning at least once in the specification and the drawings can be replaced by the different term in any place in the specification and the drawings.

The method of assigning the processing to the vertex processing section and the pixel processing section is not limited to the method described in the above embodiment. A method equivalent to the above-described method is also included within the scope of the invention. The predetermined processing to which the method according to the invention is applied is not limited to light scattering, texture coordinate calculation, lighting, and color conversion processing. The method according to the invention may also be applied to various types of processing of which the efficiency can be improved by controlling assignment of the processing to the vertex processing section and the pixel processing section.

The invention may be applied to various games. The invention may be applied to various image generation systems, such as an arcade game system, a consumer game system, a large-scale attraction system in which a number of players participate, a simulator, a multimedia terminal, a system board which generates a game image, and a portable telephone.

## Claims

1. An image generation system which generates an image, comprising:  
an object space setting section which sets an object in an object space;  
5 a vertex processing section which performs per-vertex processing; and  
a pixel processing section which performs per-pixel processing,  
wherein, when subjecting a first object which is distant from a virtual camera to  
predetermined processing which is implemented by a first processing and a second  
processing, the vertex processing section performs the first processing with a processing  
10 load lower than a processing load of the second processing, and the pixel processing  
section performs the second processing; and  
wherein, when subjecting a second object which is closer to the virtual camera  
than the first object to the predetermined processing which is implemented by a third  
processing and a fourth processing, the vertex processing section performs the third  
15 processing with a processing load higher than a processing load of the fourth processing,  
and the pixel processing section performs the fourth processing.
  
2. An image generation system which generates an image, comprising:  
an object space setting section which sets an object in an object space;  
20 a vertex processing section which performs per-vertex processing; and  
a pixel processing section which performs per-pixel processing,  
wherein, when subjecting a first object which occupies a small area on a screen to  
predetermined processing which is implemented by a first processing and a second  
processing, the vertex processing section performs the first processing with a processing  
25 load lower than a processing load of the second processing, and the pixel processing  
section performs the second processing; and  
wherein, when subjecting a second object which occupies a larger area on the

screen than the first object to the predetermined processing which is implemented by a third processing and a fourth processing, the vertex processing section performs the third processing with a processing load higher than a processing load of the fourth processing, and the pixel processing section performs the fourth processing.

5

3. The image generation system as defined in claim 1 or 2, wherein the predetermined processing is light scattering processing.

4. The image generation system as defined in claim 3,

10 wherein the vertex processing section performs the first processing which includes calculating a distance between the virtual camera and a vertex of an object; and

wherein the pixel processing section performs the second processing which includes calculating a pixel color by out-scattering and a pixel color by in-scattering and adding the pixel color by out-scattering and the pixel color by in-scattering.

15

5. The image generation system as defined in claim 3 or 4,

wherein the vertex processing section performs the third processing which includes calculating a vertex color by out-scattering and a vertex color by in-scattering; and

20 wherein the pixel processing section performs the fourth processing which includes adding a pixel color by out-scattering and a pixel color by in-scattering.

6. The image generation system as defined in claim 1 or 2, wherein the predetermined processing is processing of texture coordinates calculation.

25

7. The image generation system as defined in claim 6,

wherein the vertex processing section performs the first processing which

includes outputting data of a normal vector of a vertex; and

wherein the pixel processing section performs the second processing which includes calculating texture coordinates of a pixel by subjecting a normal vector of the pixel to coordinate transformation and calculating a pixel color by texture mapping using the texture coordinates of the pixel.

8. The image generation system as defined in claim 6 or 7,

wherein the vertex processing section performs the third processing which includes calculating texture coordinates of a vertex by subjecting a normal vector of the vertex to coordinate transformation; and

wherein the pixel processing section performs the fourth processing which includes calculating a pixel color by texture mapping using texture coordinates of a pixel.

9. The image generation system as defined in claim 1 or 2, wherein the predetermined processing is lighting processing.

10. The image generation system as defined in claim 9,

wherein the vertex processing section performs the first processing which includes outputting data of a normal vector of a vertex; and

wherein the pixel processing section performs the second processing which includes calculating light intensity of a pixel based on a normal vector of the pixel and an illumination model and calculating a pixel color based on the light intensity of the pixel.

11. The image generation system as defined in claim 9 or 10,

wherein the vertex processing section performs the third processing which includes calculating light intensity of a vertex based on a normal vector of the vertex and an illumination model; and

wherein the pixel processing section performs the fourth processing which includes calculating a pixel color based on light intensity of a pixel.

12. The image generation system as defined in claim 1 or 2, wherein the  
5 predetermined processing is color conversion processing.

13. The image generation system as defined in claim 12,  
wherein the vertex processing section performs the first processing which includes outputting data of a vertex position and a vertex color; and

10 wherein the pixel processing section performs the second processing which includes converting a pixel color using a conversion table or a conversion function.

14. The image generation system as defined in claim 12 or 13,  
wherein the vertex processing section performs the third processing which  
15 includes converting a vertex color using a conversion table or a conversion function; and  
wherein the pixel processing section performs the fourth processing which includes outputting a pixel color calculated from the converted vertex color.

15. A program for generating an image, the program causing a computer to function  
20 as:

an object space setting section which sets an object in an object space;  
a vertex processing section which performs per-vertex processing; and  
a pixel processing section which performs per-pixel processing,

wherein, when subjecting a first object which is distant from a virtual camera to  
25 predetermined processing which is implemented by a first processing and a second processing, the vertex processing section performs the first processing with a processing load lower than a processing load of the second processing, and the pixel processing

section performs the second processing; and

wherein, when subjecting a second object which is closer to the virtual camera than the first object to the predetermined processing which is implemented by a third processing and a fourth processing, the vertex processing section performs the third  
5 processing with a processing load higher than a processing load of the fourth processing, and the pixel processing section performs the fourth processing.

16. A program for generating an image, the program causing a computer to function as:

10 an object space setting section which sets an object in an object space;  
a vertex processing section which performs per-vertex processing; and  
a pixel processing section which performs per-pixel processing,

wherein, when subjecting a first object which occupies a small area on a screen to predetermined processing which is implemented by a first processing and a second  
15 processing, the vertex processing section performs the first processing with a processing load lower than a processing load of the second processing, and the pixel processing section performs the second processing; and

wherein, when subjecting a second object which occupies a larger area on the screen than the first object to the predetermined processing which is implemented by a  
20 third processing and a fourth processing, the vertex processing section performs the third processing with a processing load higher than a processing load of the fourth processing, and the pixel processing section performs the fourth processing.

17. A computer-readable information storage medium storing the program as defined  
25 in claim 15 or 16.



For Information

49

**Application No:** GB0623156.7

**Examiner:** Iwan Thomas

**Claims searched:** 1, 2, 15 and 16

**Date of search:** 20 February 2007

### Patents Act 1977: Search Report under Section 17

#### Documents considered to be relevant:

Category	Relevant to claims	Identity of document and passage or figure of particular relevance
A	-	US 2006/0221073 A1 (TELER)
A	-	US 2006/0044313 A1 (LAKE)

#### Categories:

X	Document indicating lack of novelty or inventive step	A	Document indicating technological background and/or state of the art.
Y	Document indicating lack of inventive step if combined with one or more other documents of same category	P	Document published on or after the declared priority date but before the filing date of this invention
&	Member of the same patent family	E	Patent document published on or after, but with priority date earlier than, the filing date of this application.

#### Field of Search:

Search of GB, EP, WO & US patent documents classified in the following areas of the UKC<sup>X</sup>:

H4T

Worldwide search of patent documents classified in the following areas of the IPC

G06T

The following online and other databases have been used in the preparation of this search report

Online: WPI, EPODOC