



US 20080169252A1

(19) **United States**

(12) **Patent Application Publication**
O’Risky

(10) **Pub. No.: US 2008/0169252 A1**

(43) **Pub. Date: Jul. 17, 2008**

(54) **SPACE SAVING HOLDER FOR TOOLS AND MISCELLANEOUS ITEMS**

Publication Classification

(51) **Int. Cl.**
A47F 7/00 (2006.01)
(52) **U.S. Cl.** **211/70.6**
(57) **ABSTRACT**

(76) **Inventor: Jeff O’Risky, Evansville, IN (US)**

Correspondence Address:
Gary K. Price, Esq., Bowers Harrison, LLP
25 N.W. Riverside Drive, P. O. Box 1287
Evansville, IN 47706-1287

(21) **Appl. No.: 12/008,359**

(22) **Filed: Jan. 10, 2008**

Related U.S. Application Data

(60) **Provisional application No. 60/879,919, filed on Jan. 11, 2007.**

A rotatable space saving holder for storing tools and miscellaneous items including a main body defined by a base portion, a top portion, and four side walls, a plurality of holding members selectively positioned on the side walls for holding tools and miscellaneous items. The holder further includes rotary means so that the main body is rotatable, allowing a user access to all four side walls of the main body while stationary. A first end of an upper retainer member is attached to the top portion of the saver holder, and a second end of the retainer member, opposite the first end, is attached to a mounting surface. In application, the upper retainer member provides additional stability to the space saver holder in a vertical orientation.

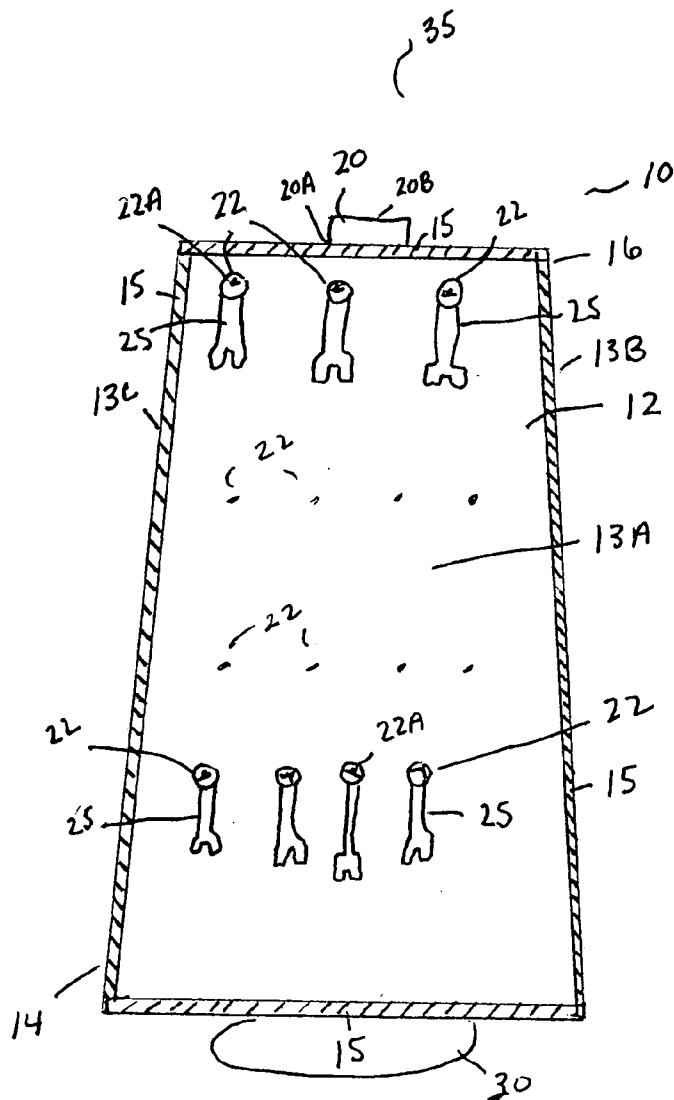

Fig. 1

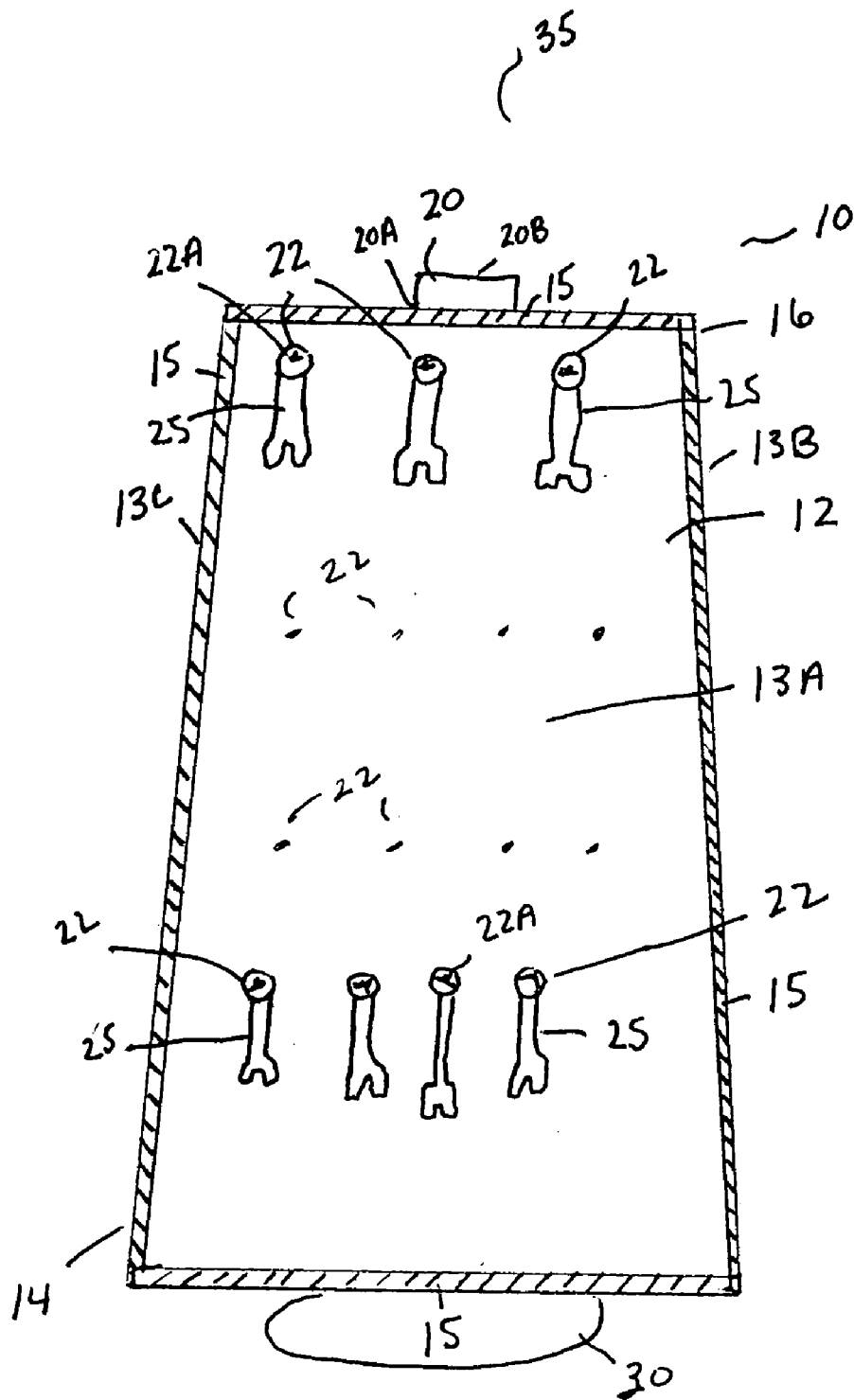

Fig. 2

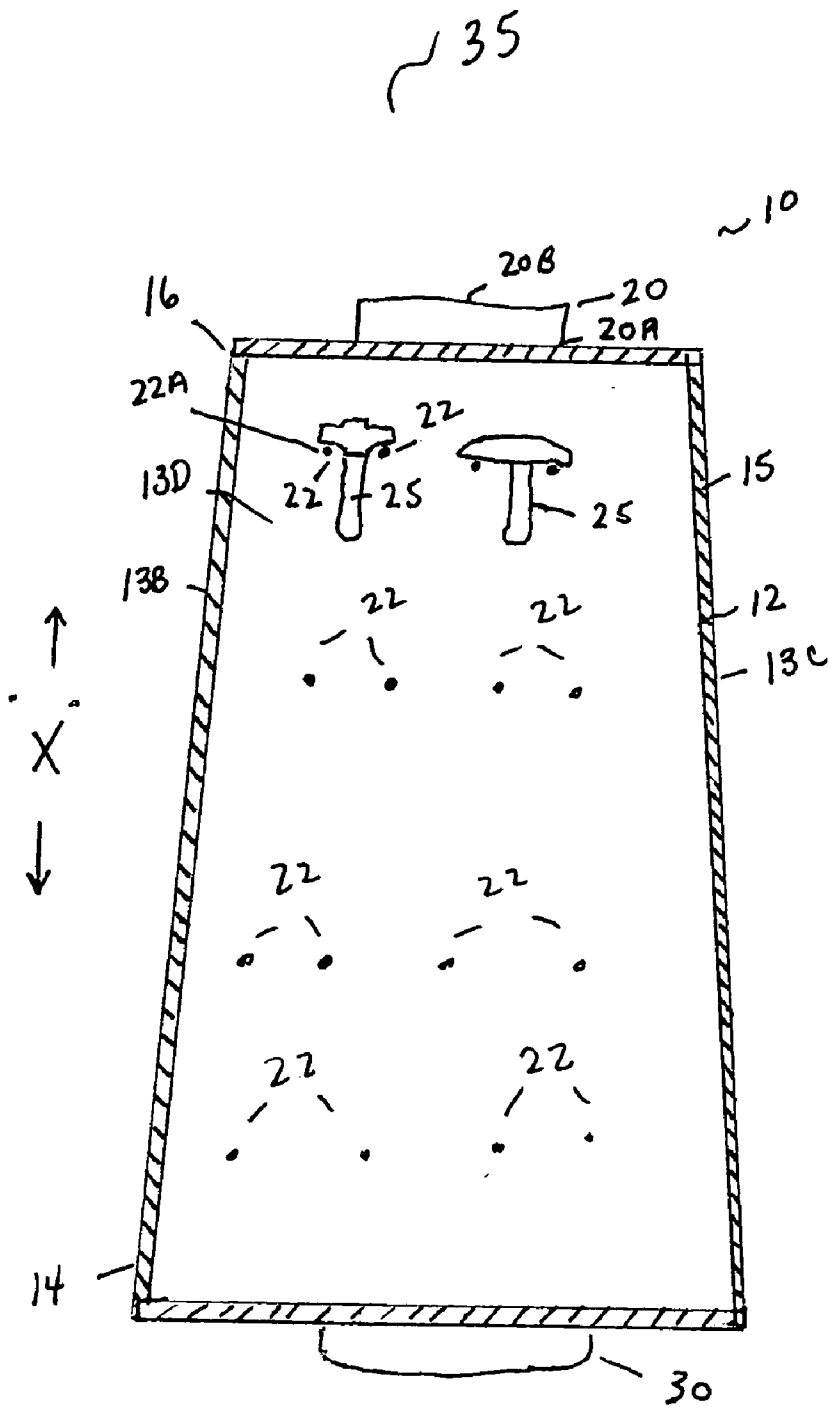
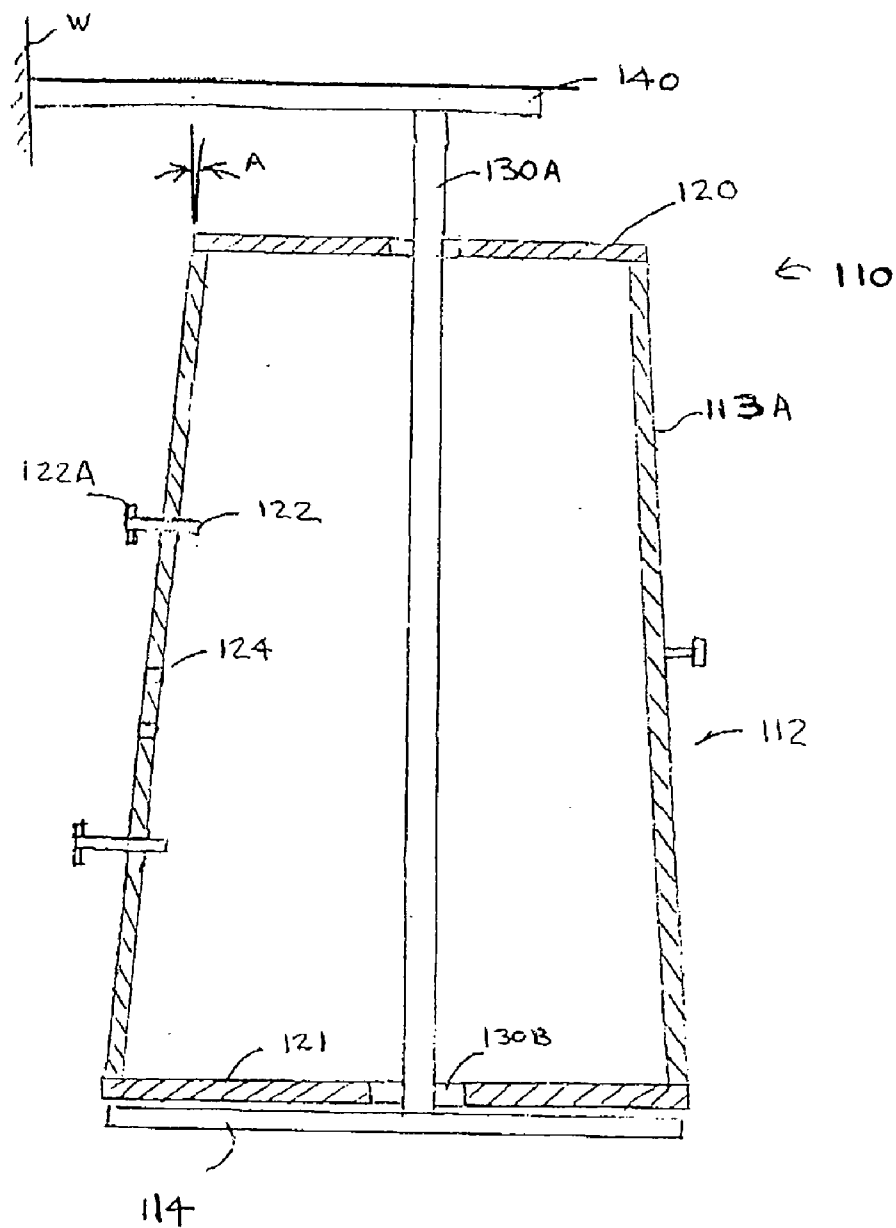

Fig. 3



SPACE SAVING HOLDER FOR TOOLS AND MISCELLANEOUS ITEMS

CROSS REFERENCES TO RELATED APPLICATIONS

[0001] U.S. Provisional Application for Patent No. 60/879, 919, filed Jan. 11, 2007, with title "Space Saving Holder for Tools and Miscellaneous Items" which is hereby incorporated by reference. Applicant claims priority pursuant to 35 U.S.C. par. 119(e)(i).

STATEMENT AS TO RIGHTS TO INVENTIONS MADE UNDER FEDERALLY SPONSORED RESEARCH AND DEVELOPMENT

[0002] Not Applicable

BACKGROUND OF THE INVENTION

[0003] 1. Field of the Invention

[0004] This invention relates generally to a tool holder and more particularly, to a space saving rotatable holder for tools and miscellaneous items when said tools and items are not in use.

[0005] 2. Brief Description of Prior Art

[0006] In many instances, after they are used, tools and items are merely placed in a drawer or bin together with other tools and items. As a result, it is often difficult to find a particular tool or item when it is desired to be used. At other times, the tools or items are misplaced in some forgotten place so that they are difficult to find.

[0007] Various types of storage arrangements are known in the prior art for storing tools, miscellaneous items, and like articles on a wall or other mounting surface. Such arrangements may include hooks or racks which are secured to the wall, such as with suitable mechanical fasteners. The use of so-called pegboard, comprising an array of holes into which hooks or other racks can be selectively mounted, is also known, with this arrangement permitting the removable hooks or like support elements to be positioned as desired for the particular articles to be stored. Unfortunately, storage devices such as noted above do not always provide sufficiently secure and versatile storage of articles. Because articles to be stored may vary greatly in size and weight, not all racks or hooks can be readily employed for a wide variety of articles. In the case of pegboard storage arrangements, the typical hooks or racks which are mounted in the board are generally secured therein under the influence of gravity, and can be easily dislodged, thus distracting from convenient and secure use.

[0008] It is therefore desirable to provide a storage arrangement for tools and miscellaneous items which is space friendly, versatile in use, while still providing convenient, yet secured adjustment for different types of articles.

[0009] As will be seen from the subsequent description, the preferred embodiments of the present invention overcome disadvantages of the prior art.

SUMMARY OF THE INVENTION

[0010] In accordance with the present invention, a space saving holder for tools and miscellaneous items is provided. The space saving holder generally includes a main body having a base portion, a top portion, and four side walls. A plurality of tool retaining or holding members is selectively provided on the sides of the walls for holding tools and

miscellaneous items. Each of the tool holding members include a member such as a hook for holding the tool. Resiliency of the holding members acts to secure each of the hook members to the respective holding member, yet permits each of the hook members to be removed from the holding member as required. Preferably, both the upper and lower portions of each of the side walls define the plurality of laterally spaced holding members, thus permitting insertion of tools, miscellaneous items and the like for storage along the entire length and width of the walls. This arrangement facilitates highly versatile and secure mounting of tools, or like articles, in a wide variety of combinations and configurations, thus permitting convenient customization by owners and like consumers.

[0011] The space saver holder further includes rotary means so that the main body is rotatable. The rotating means allows a user access to all four side walls of the main body while stationary.

[0012] A first end of an upper retainer member is attached to the top portion of the saver holder, and a second end of the retainer member, opposite the first end, is preferably attached to a wall or other mounting surface. In the preferred embodiment, the upper retainer member is attached in perpendicular relationship with the vertical length of the space saver holder. Alternatively, the first end of the retainer member is attached to the top portion of the holder, and the second end is attached to the ceiling. In application, the upper retainer member provides additional stability to the space saver holder in order to assist application of the space saver holder in a vertical orientation.

[0013] The space saving holder in accordance with the present invention provides a display function in order for the user to visually locate the selected tool easily. In addition, it provides an organized storage function for tools, miscellaneous items, and the like. Further, with application of the upper retainer member as discussed, the holder can store articles of various size and weight and continues to maintain a vertical orientation.

BRIEF DESCRIPTION OF THE DRAWINGS

[0014] FIG. 1 is a front perspective view of a preferred embodiment of the present invention, a space saving holder for tools and miscellaneous items.

[0015] FIG. 2 shows a side of the space saving holder having different configurations of the tool holding members.

[0016] FIG. 3 is a cross-sectional view of a second embodiment of the space saving holder.

DESCRIPTION OF THE PREFERRED EMBODIMENT

[0017] In accordance with the present invention, a space saving holder for tools and miscellaneous items is disclosed. The space saving holder is directed to a rotating apparatus for holding tools, miscellaneous items, and the like. Specifically, it will be noted in the drawings that the space saving holder of the present invention provides a versatile, convenient and secure means for holding different types of articles. In the broadest context, the space saving holder for tools and miscellaneous items of the present invention consists of components configured and correlated with respect to each other so as to attain the desired objective.

[0018] FIGS. 1-2 illustrate a preferred embodiment of a space saver holder 10 made in accordance with the present

invention. Holder 10 generally includes a main body 12 including a base portion 14, a top portion 16, and four side walls 13A, 13B, 13C and 13D extending upright between the base and top portions 14, 16, respectively. The holder 10 can further include edging 15 for attaching the edges of the walls 13A, 13B, 13C and 13D to form a substantially rectangular configuration as shown. As will be described, the space saver holder 10 further includes an upper retainer member 20 to assist application of the space saver holder 10 in a vertical orientation.

[0019] A plurality of tool retaining or holding members 22 is selectively provided on the sides of the walls 13A, 13B, 13C and 13D for holding tools and miscellaneous items 25. The above-mentioned tool holding members 22 are spaced apart from each other and thus individually define a tool holding area (not labeled) for each tool 25.

[0020] Each of the tool holding members 22 include a resilient hook member 22A for holding the respective tool 25. The tool holding members 22 having the hook member 22A are selectively, removably positionable on the walls 13A, 13B, 13C, 13D. Likewise, and as will be understood, the hook member 22A can be removed from the respective holding member 22.

[0021] The tool holding members 22 as defined prevents tools 25 from falling from the holder 10 that generally happens in conventional tool racks, but also provides convenient retrieval of the tools.

[0022] Highly stable and secure mounting of the tool retaining or holding members 22 on the walls 13A, 13B, 13C and 13D is achieved by configuring each of the holding members 22 to resiliently receive the hook members 22A. Resiliency of the holding members 22 acts to secure each of the hook members 22A to the respective holding member 22, yet permits each of the hook members 22A to be removed from the holding member 22 as required.

[0023] Versatility of the present invention is further enhanced by providing the plurality of laterally spaced, article receiving holding members 22 about the side walls 13A, 13B, 13C and 13D. Preferably, both the upper and lower portions of each of the side walls define the plurality of laterally spaced holding members 22, thus permitting insertion of tools, miscellaneous items and the like for storage along the entire length and width of the walls 13A, 13B, 13C and 13D.

[0024] The present invention contemplates the provision of a wide variety of different size and shaped tools and storage attachments by defining the plurality of spaced apart tool retaining or holding members 22. As a result, each of the side walls 13A, 13B, 13C and 13D define a plurality of spaced apart, hook-like article-receiving members 22 for receipt of various tools and items, such as a set of wrenches, for example, and as illustrated in the drawings, to be carried by the saver holder 10. It should be understood this arrangement facilitates highly versatile and secure mounting of tools, such as illustrated, or like articles, in a wide variety of combinations and configurations, thus permitting convenient customization by owners and like consumers.

[0025] The tool retaining or holding members 22 preferably comprise metallic material for strength, such as steel or the like. While the hook members 22A is elongated, it will be appreciated that it can be employed in any of a variety of different lengths.

[0026] The space saver holder 10 further includes rotary means 30 so that the main body 12 is rotatable. The rotating

means 30 allows a user access to all four side walls 13A, 13B, 13C and 13D, of the main body 12 while stationary. The rotating means 30 can include a rotary disc (not shown) attached to the base and top portions 14, 16, respectively. Alternatively, the rotary means 30 can include a support rod (shown in FIG. 3) that is vertically disposed through the length of the main body 12 and attached to the base and top portions 14, 16, so that rotation of the support rod within the base and top portions 14, 16 causes the main body 12 to likewise rotate.

[0027] In the preferred embodiment, a first end 20A of the upper retainer member 20 is appropriately attached to the top portion 16 of the saver holder 10, and a second end 20B, opposite the first end 20A, is attached to a wall or other mounting surface 35. In the preferred embodiment, the upper retainer member 20 is attached in perpendicular relationship with the vertical length of the space saver holder 10. Alternatively, the upper retainer member 20 can be positioned along an axis "X" of the length of the space saver holder 10. In this regard, the first end 20A of the retainer member 20 is attached to the top portion 16 of the holder 10, and the second end 20B is attached to the ceiling (not shown). In application, the upper retainer member 20 provides additional stability to the space saver holder 10 in order to assist application of the space saver holder 10 in a vertical orientation. The space saving holder in accordance with the present invention provides a display function in order for the user to visually locate the selected tool easily. In addition, it provides an organized storage function for tools, miscellaneous items, and the like. Further, with application of the upper retainer member 20 as discussed, the holder 10 can store articles of various size and weight and continues to maintain a vertical orientation.

[0028] FIG. 3 shows a cross-sectional view of a second embodiment of the tool holder 110. As can be seen, each side wall 113A-D is tilted at an angle "A" with respect to the vertical such that the main body 112 forms a truncated pyramid. This angle aids in tool retention tending to make the tools rest against the walls 113A-D and makes the holder 110 more stable in rotation. This second embodiment includes a central pipe or rod 130A that provides an axle for rotation of the tool holder 110, alternatively, rollers could be provided between the surface 121 and the base 114. The axle 130A is mounted to the top retainer member 120 and to the bottom retainer member 121 with bearings 130B making the tool holder easy to rotate. The tool holder 110 sits on a base 114 that can be placed on the floor or on a work bench or similar flat horizontal space. The rod 130A extends through the top 120 and can be attached to a mounting surface such as the ceiling (not shown) or using a bracket 140 can be attached to a wall "W".

[0029] FIG. 3 shows that each wall 113A-D can include a plurality of holes 124 into which tool holding members 122 can be selectively placed. Each tool holding member 122 can include a resilient hook 122A that attaches to the tool holding members 122 and acts to help keep a tool to be held in place on the wall 113A-D. A wall 113A-D can include a plurality of holes 124 that can be placed in a grid pattern for use by the customer or could be arranged to hold specific tools that might be sold with the holder as part of a set of tools for example.

[0030] Although the description above contains many specificities, these should not be construed as limiting the scope of the invention but as merely providing illustrations of some of the presently preferred embodiments of this invention.

[0031] It would be obvious to those skilled in the art that modifications may be made to the embodiments described above without departing from the scope of the present invention. Thus the scope of the invention should be determined by the appended claims in the formal application and their legal equivalents, rather than by the examples given.

I claim:

1. A space saving holder for tools and miscellaneous items comprising:

a main body comprising a base portion, a top portion, and four side walls disposed between said base and top portions,

a plurality of tool retaining members selectively provided on said side walls for holding tools, each of said tool retaining members include a hook member for additionally holding said tool, wherein said hook member is removable from said retaining member,

a rotary means such that said main body is rotatable, an upper retainer member having a first end and a second end opposite said first end, wherein the first end is attached to said top portion of the holder, and said second end is attached to a mounting surface.

2. The holder as recited in claim 1, wherein said upper retainer member is attached in perpendicular relationship with the vertical length of the space saver holder.

3. The holder as recited in claim 1, wherein a length of said holder defines an axis, and wherein said upper retainer member is attached along said axis.

4. The holder as recited in claim 3, wherein said side walls sit at an angle to vertical tilting toward said axis such that said main body forms a truncated pyramid.

5. The holder as recited in claim 3, wherein said rotary mounting includes a central axial rod held between said upper retainer and said base.

6. A space saving holder for tools comprising:

a main body having a base portion, a top portion, and side walls disposed between the base and top portions,

each side wall having a plurality of selectively removable tool retaining members for holding tools, each of said tool holding members include a hook member for additionally holding said tool, wherein said hook member is removable from said retaining member,

a rotary mounting such that said main body is rotatable, an upper retainer member having a first end and a second end opposite said first end, wherein the first end is

attached to said top portion of the holder and said second end is attached to a mounting surface.

7. The holder as recited in claim 6, wherein a length of said holder defines a vertical axis, and wherein said upper retainer member is attached to a central rod on said axis.

8. The holder as recited in claim 7, wherein said upper retainer member is attached in perpendicular relationship with the central of the space saver holder.

9. The holder as recited in claim 8, wherein said side walls sit at an angle to vertical tilting toward said axis such that said main body forms a truncated pyramid.

10. The holder as recited in claim 9, wherein said central axial rod is held between said upper retainer and said base.

11. The holder as recited in claim 10, wherein said tool holding members are rigid pins and said hooks are resilient material.

12. A holder for tools comprising:

a main body having a base portion, a top portion, and side walls disposed between the base and top portions,

each side wall having a plurality of holes and selectively removable tool retaining members for holding tools adapted to fit in said holes, each of said tool holding members include a hook member for additionally holding said tool wherein said hook member is removable from said retaining member,

a rotary mounting such that said main body is rotatable, an upper retainer member having a first end and a second end opposite said first end, wherein the first end is attached to said top portion of the holder and said second end is attached to a surface wherein said retainer member having a length sufficient that said main body can rotate without interfering with said surface.

13. The holder as recited in claim 12, wherein said side walls sit at an angle to vertical tilting toward a central axis of said main body such that said main body forms a truncated pyramid sitting on said base.

14. The holder as recited in claim 13, wherein said upper retainer member is attached to a central rod on said axis.

15. The holder as recited in claim 14, wherein said tool holding members are rigid pins and said hooks are resilient material.

16. The holder as recited in claim 15, wherein said central axial rod is held between said upper retainer and said face.

* * * * *