



(19) **United States**

(12) **Patent Application Publication**

**Hwang et al.**

(10) **Pub. No.: US 2001/0050267 A1**

(43) **Pub. Date: Dec. 13, 2001**

(54) **METHOD FOR ALLOWING A STABLE POWER TRANSMISSION INTO A PLASMA PROCESSING CHAMBER**

application No. 08/920,283, filed on Aug. 26, 1997, now abandoned.

**Publication Classification**

(76) Inventors: **Jeng H. Hwang**, Cupertino, CA (US);  
**Steve S.Y. Mak**, Pleasanton, CA (US);  
**Kang-Lie Chiang**, San Jose, CA (US)

(51) **Int. Cl.<sup>7</sup>** ..... **C23F 1/00**  
(52) **U.S. Cl.** ..... **216/67; 216/2; 216/55; 216/75**

Correspondence Address:  
**Applied Materials, Inc.**  
**Patent Counsel**  
**P.O. Box 450-A**  
**Santa Clara, CA 95052 (US)**

(57) **ABSTRACT**

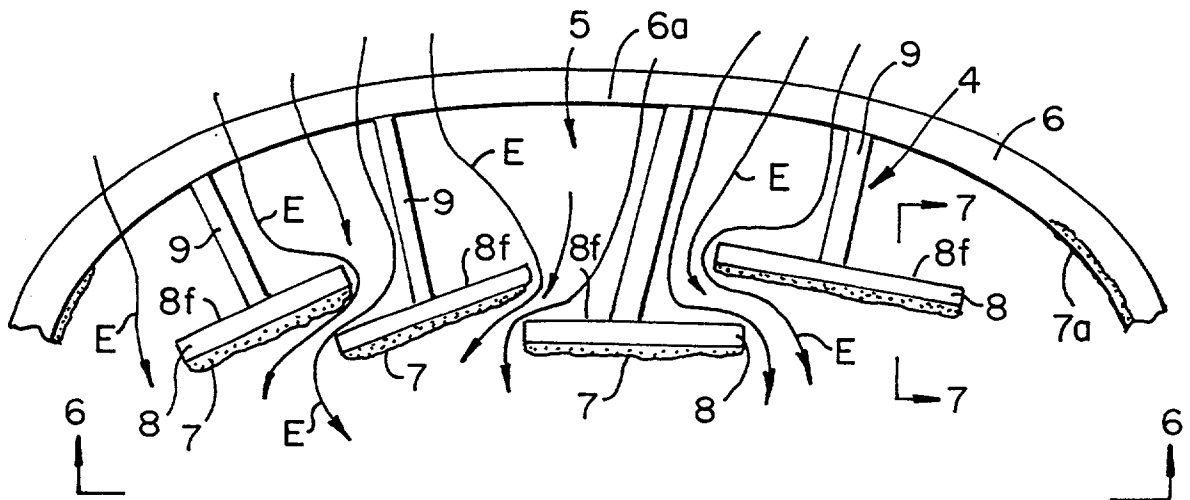
A method of processing a metal layer on a substrate. The method comprises disposing the substrate in a chamber having a dielectric member and processing gas. An interior surface of the dielectric member is heated to a temperature above about 150° C. and the metal layer is processed when processing power is passed through the heated dielectric member. Heating of the interior surface of the dielectric member essentially prevents deposits from forming on the interior surface and allows a stable power transmission through the dielectric member.

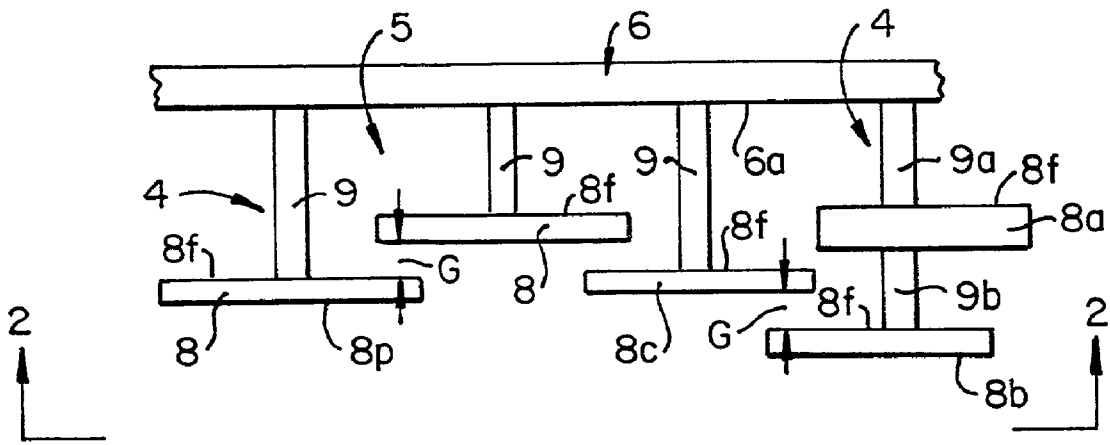
(21) Appl. No.: **09/896,786**

(22) Filed: **Jun. 29, 2001**

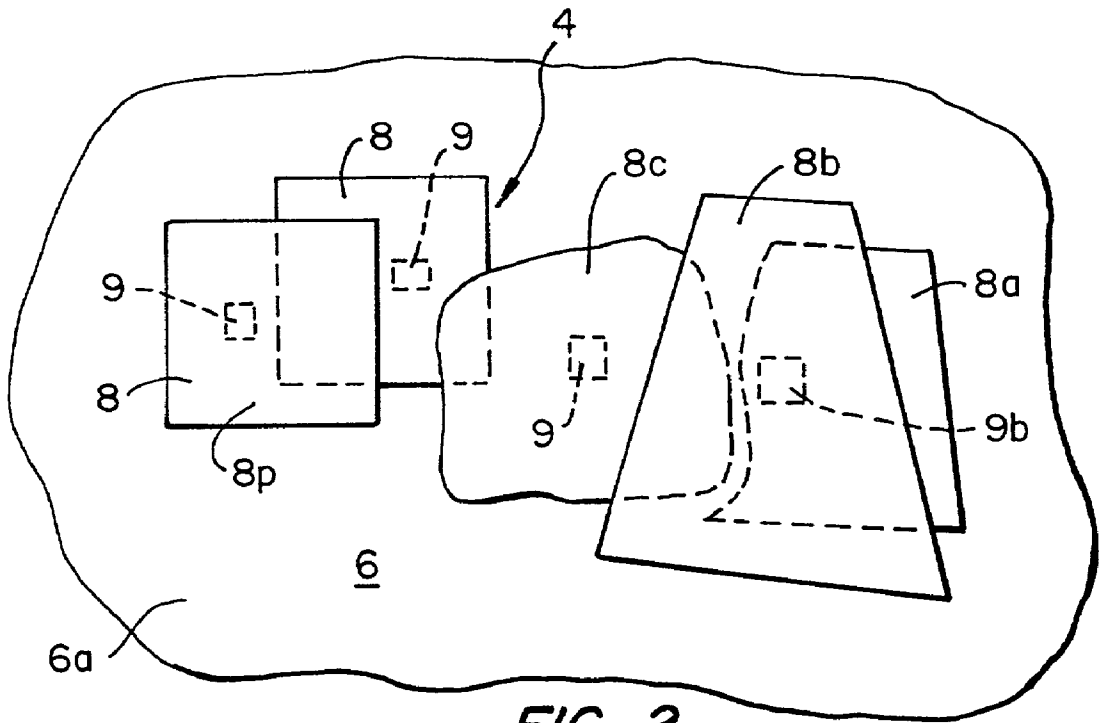
**Related U.S. Application Data**

(63) Continuation of application No. 09/124,291, filed on Jul. 29, 1998, which is a continuation-in-part of

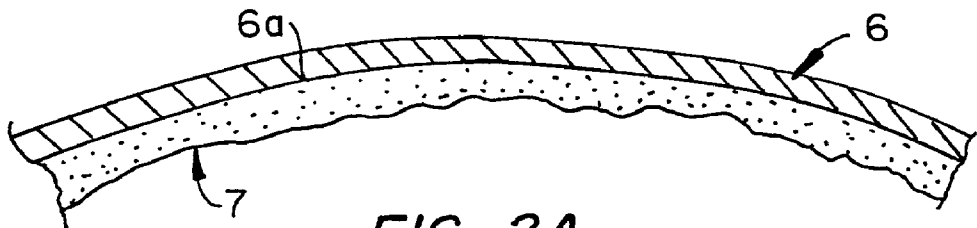




**FIG. 1.**



**FIG. 2.**



**FIG. 2A.**

PRIOR ART

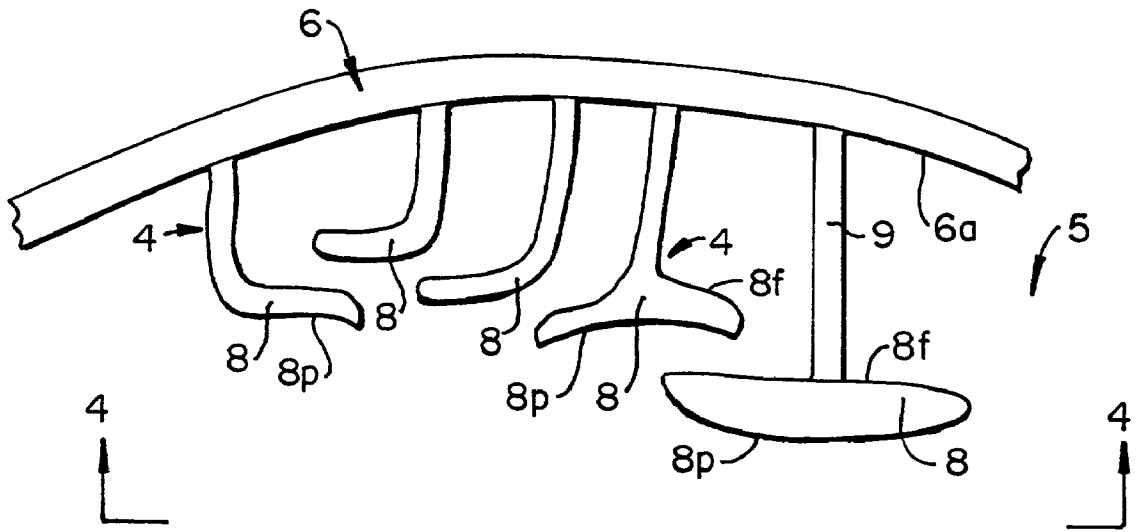


FIG. 3.

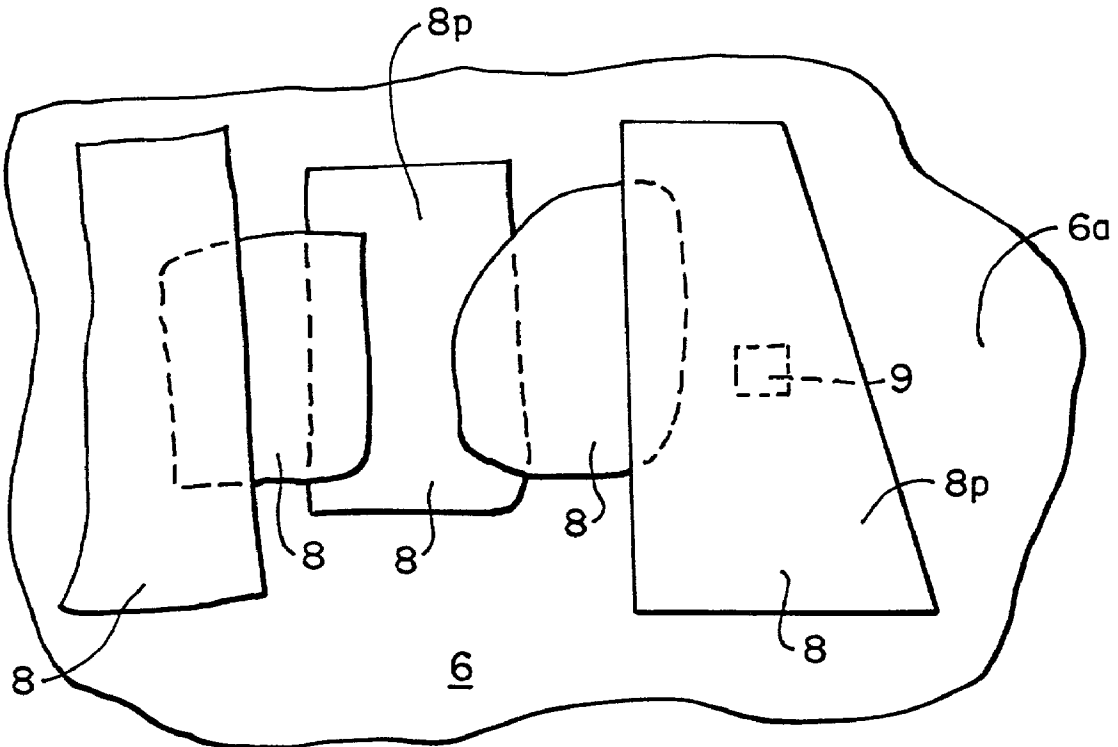


FIG. 4.

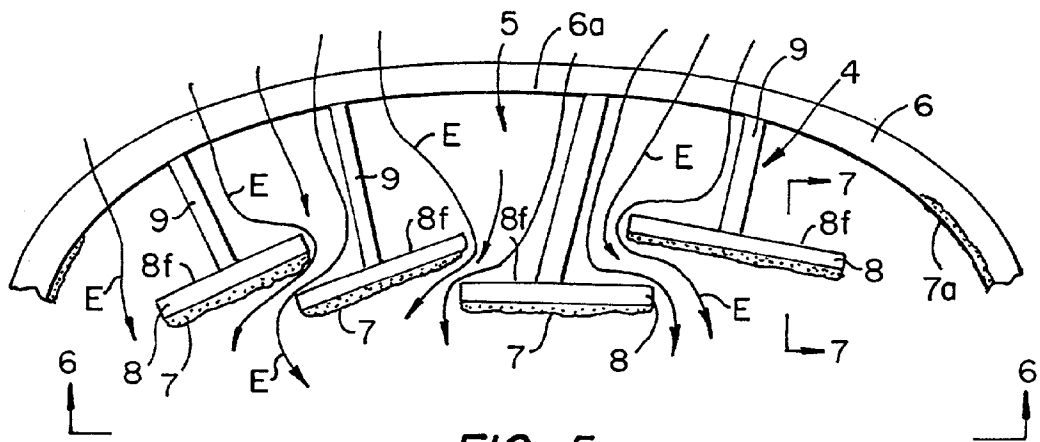


FIG. 5.

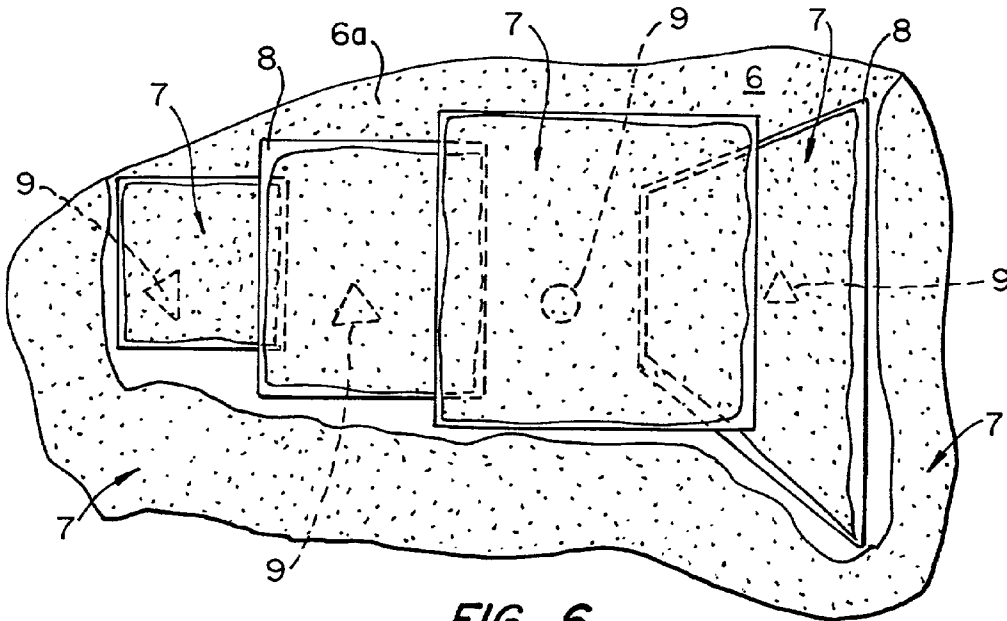


FIG. 6.

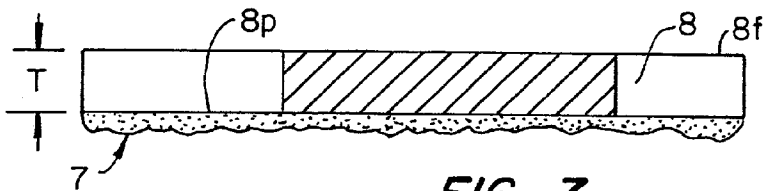
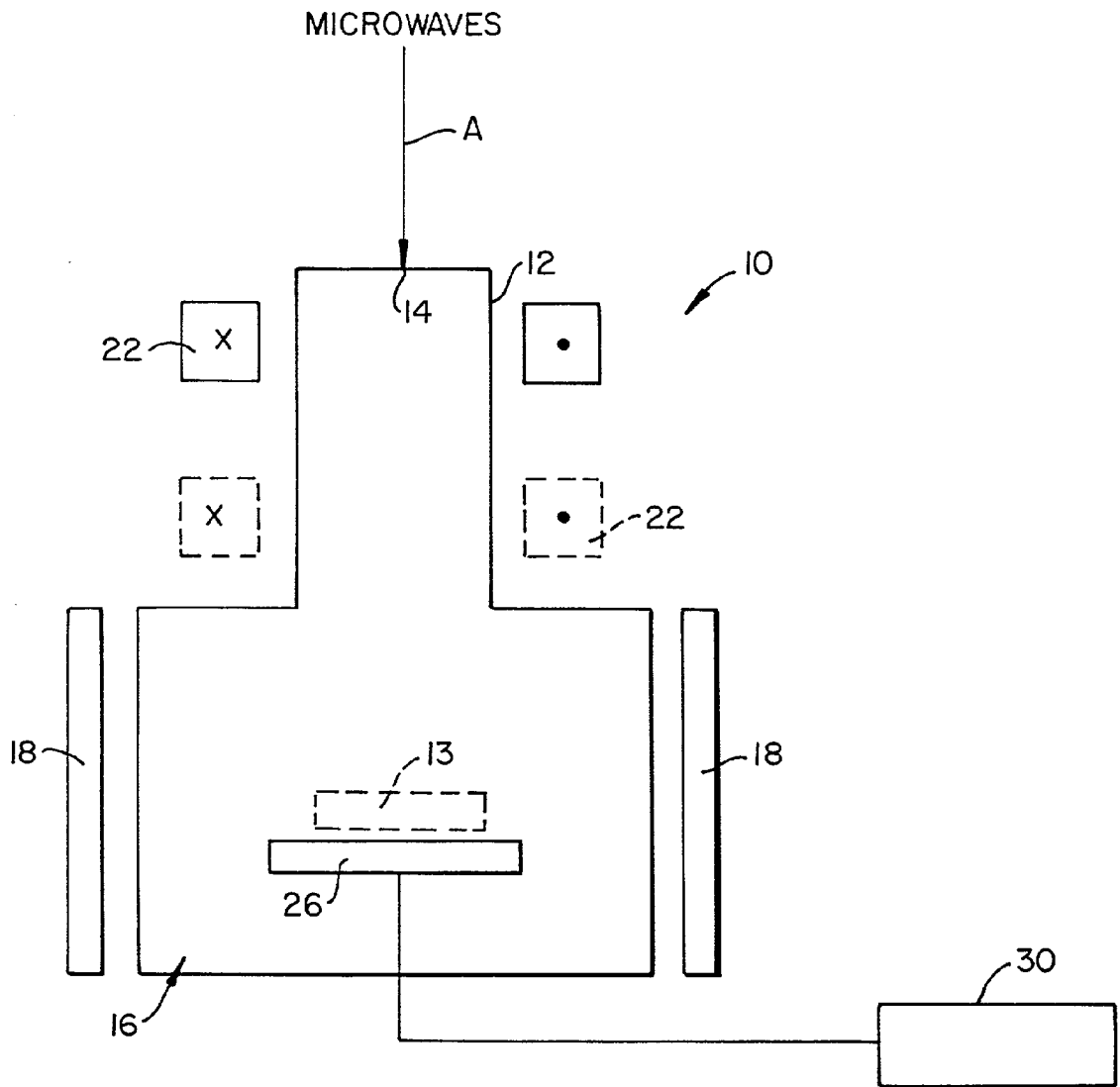
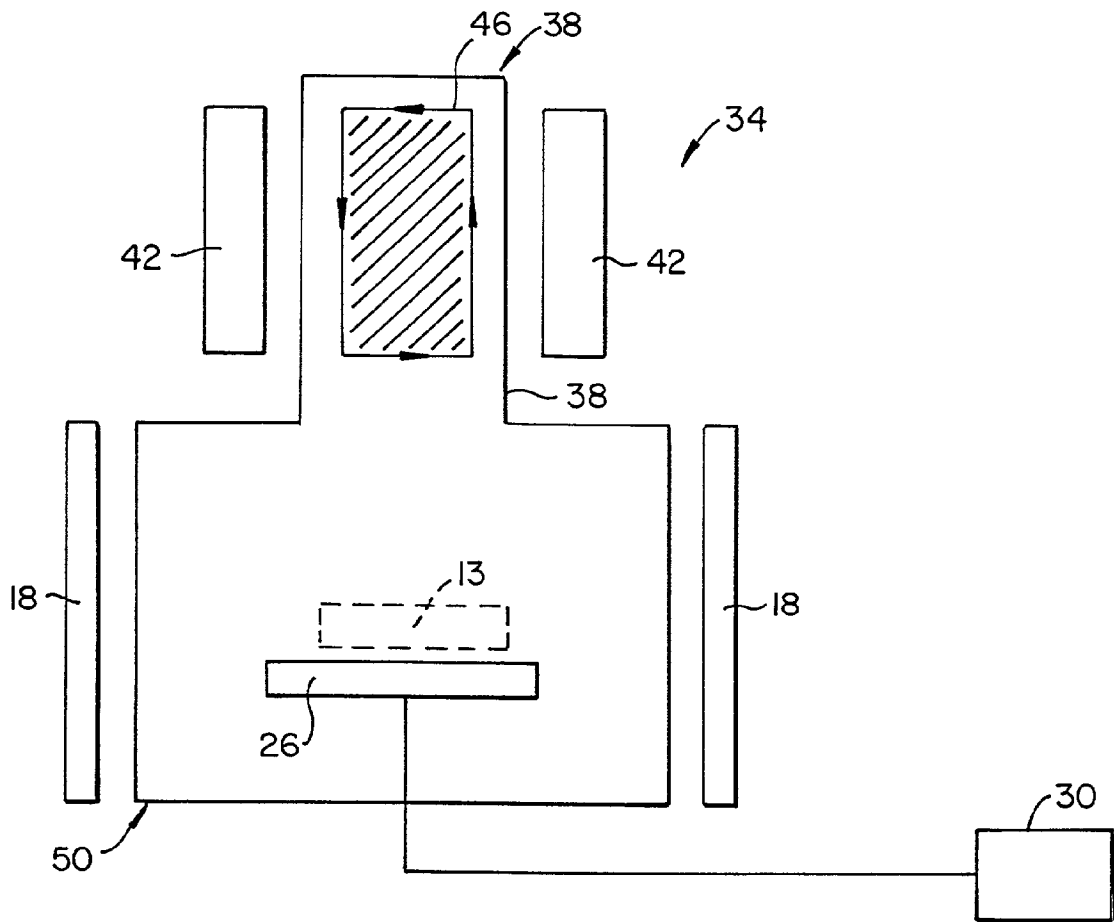


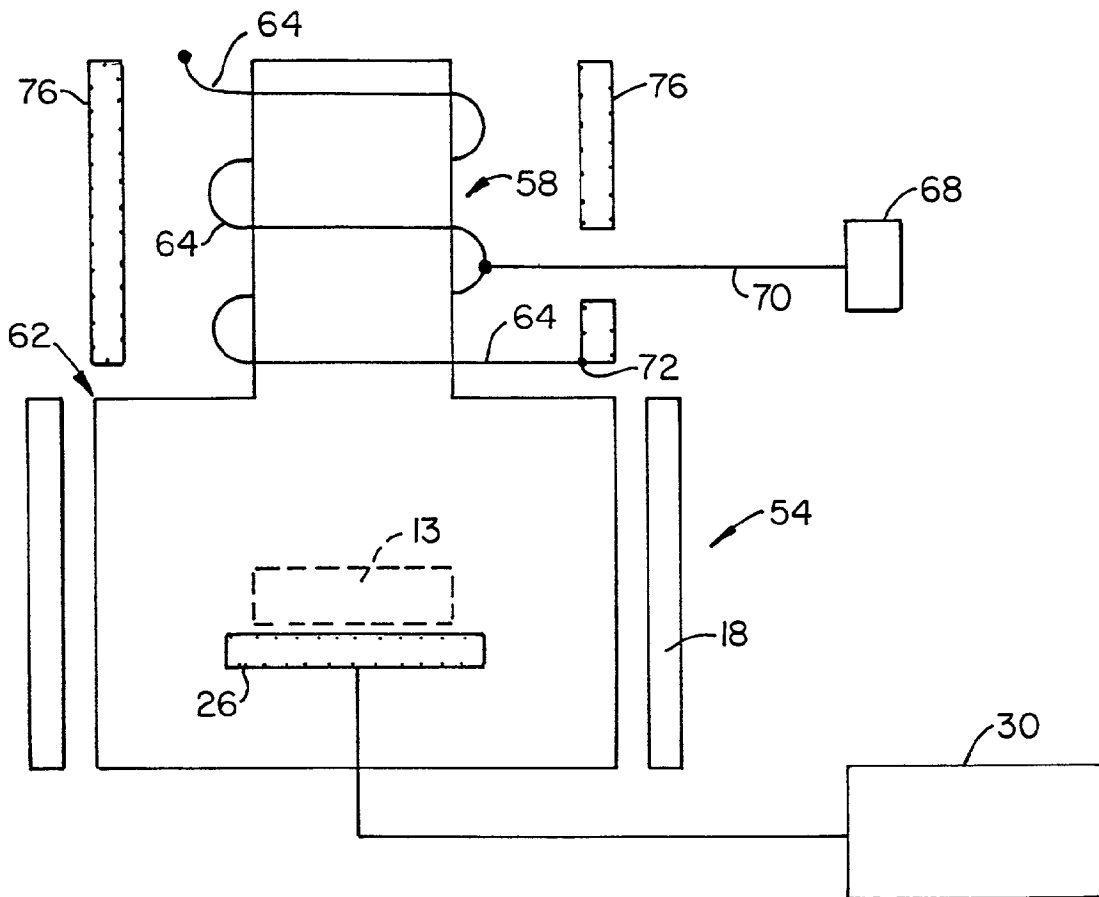
FIG. 7.



**FIG. 8.**  
PRIOR ART

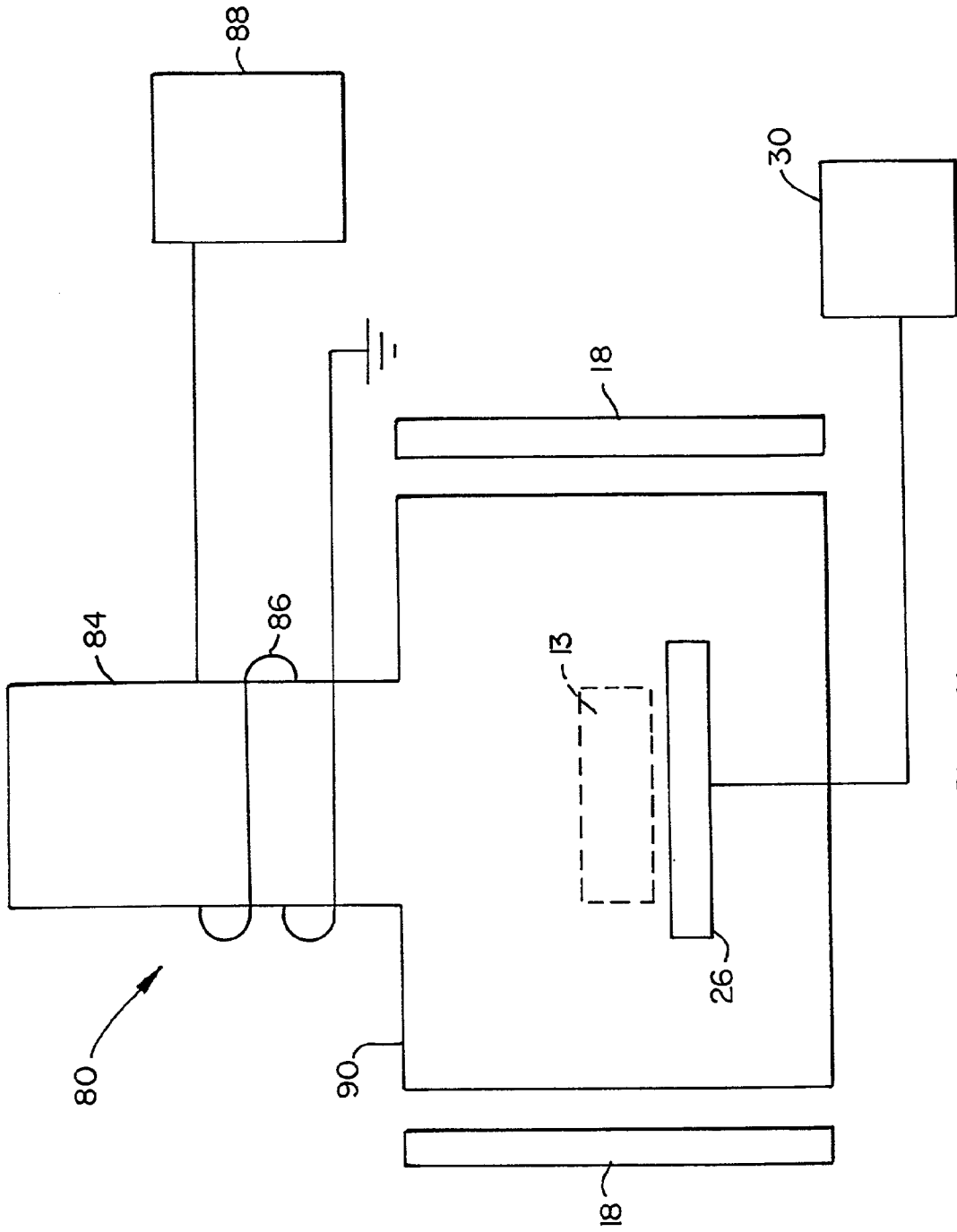


**FIG. 9.**  
PRIOR ART



**FIG. 10.**

PRIOR ART



**FIG. 11.**  
PRIOR ART

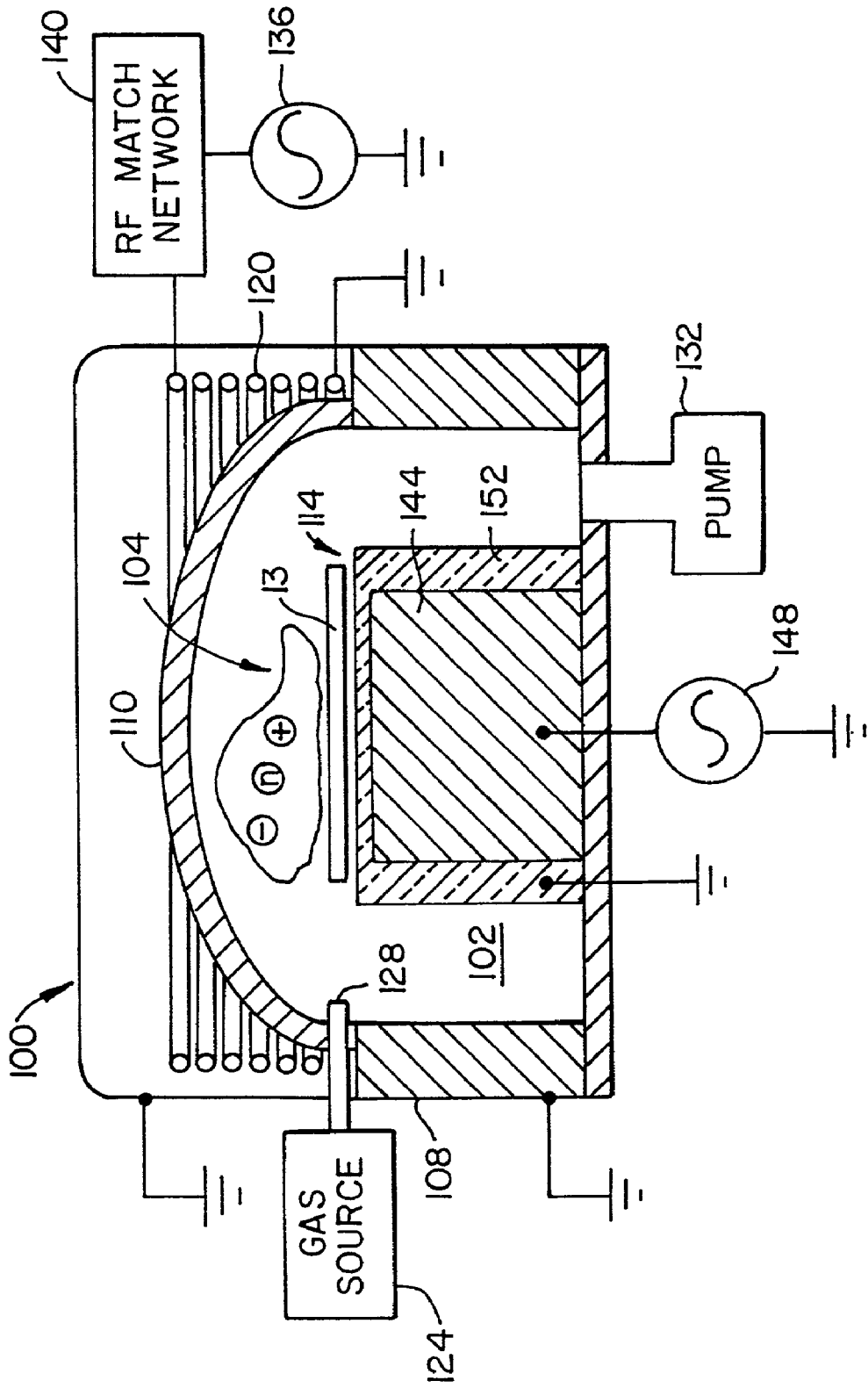


FIG. 12.

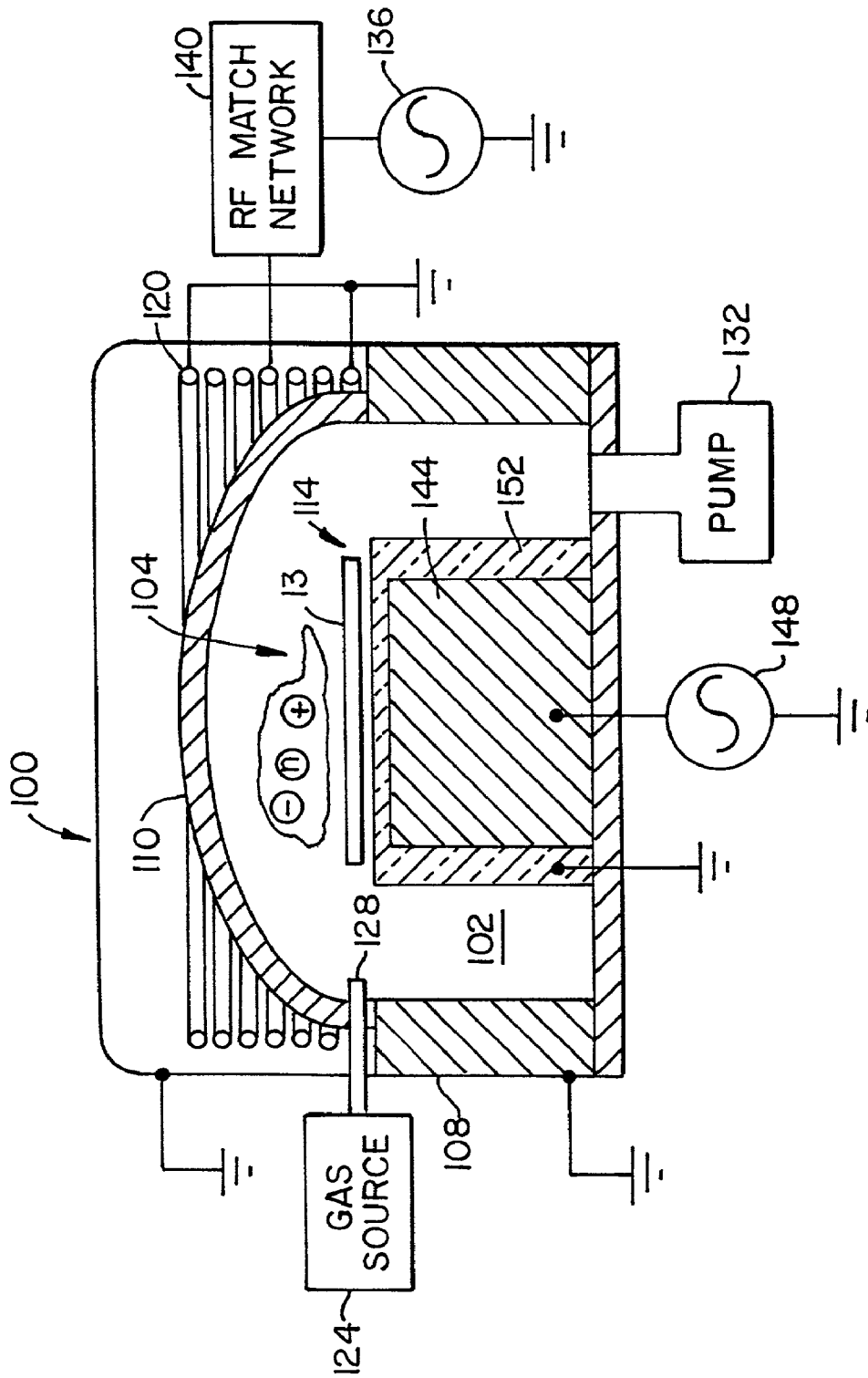


FIG. 13.

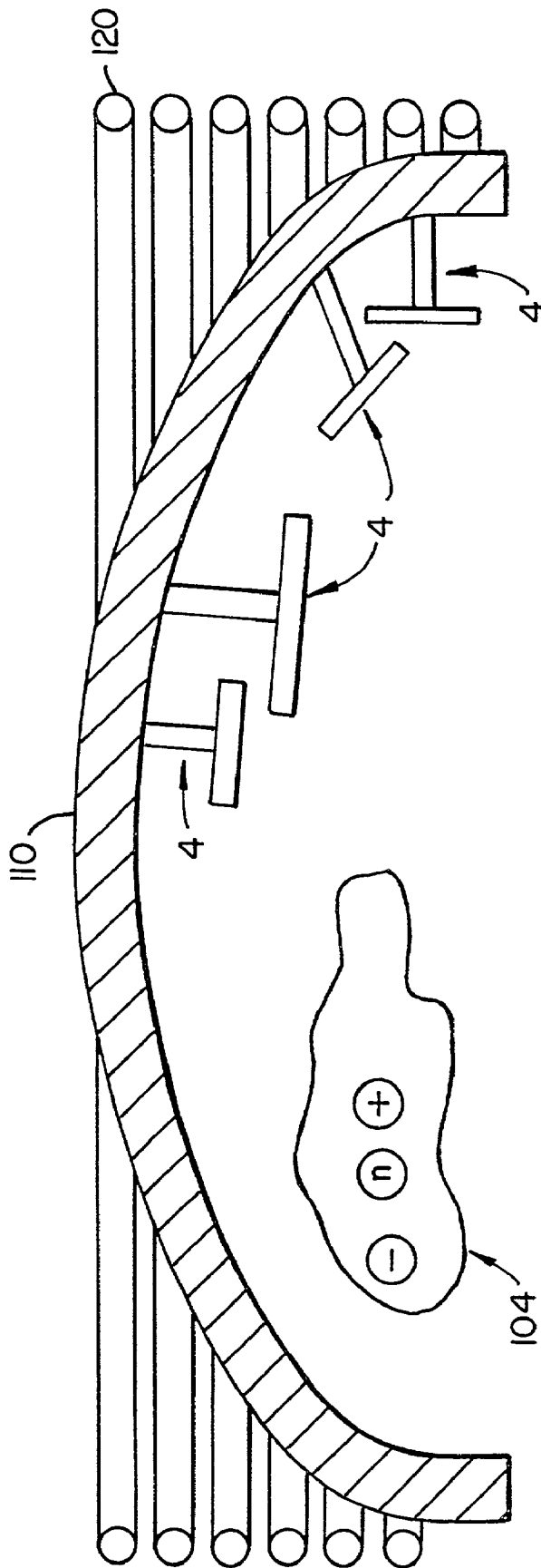


FIG. 14A

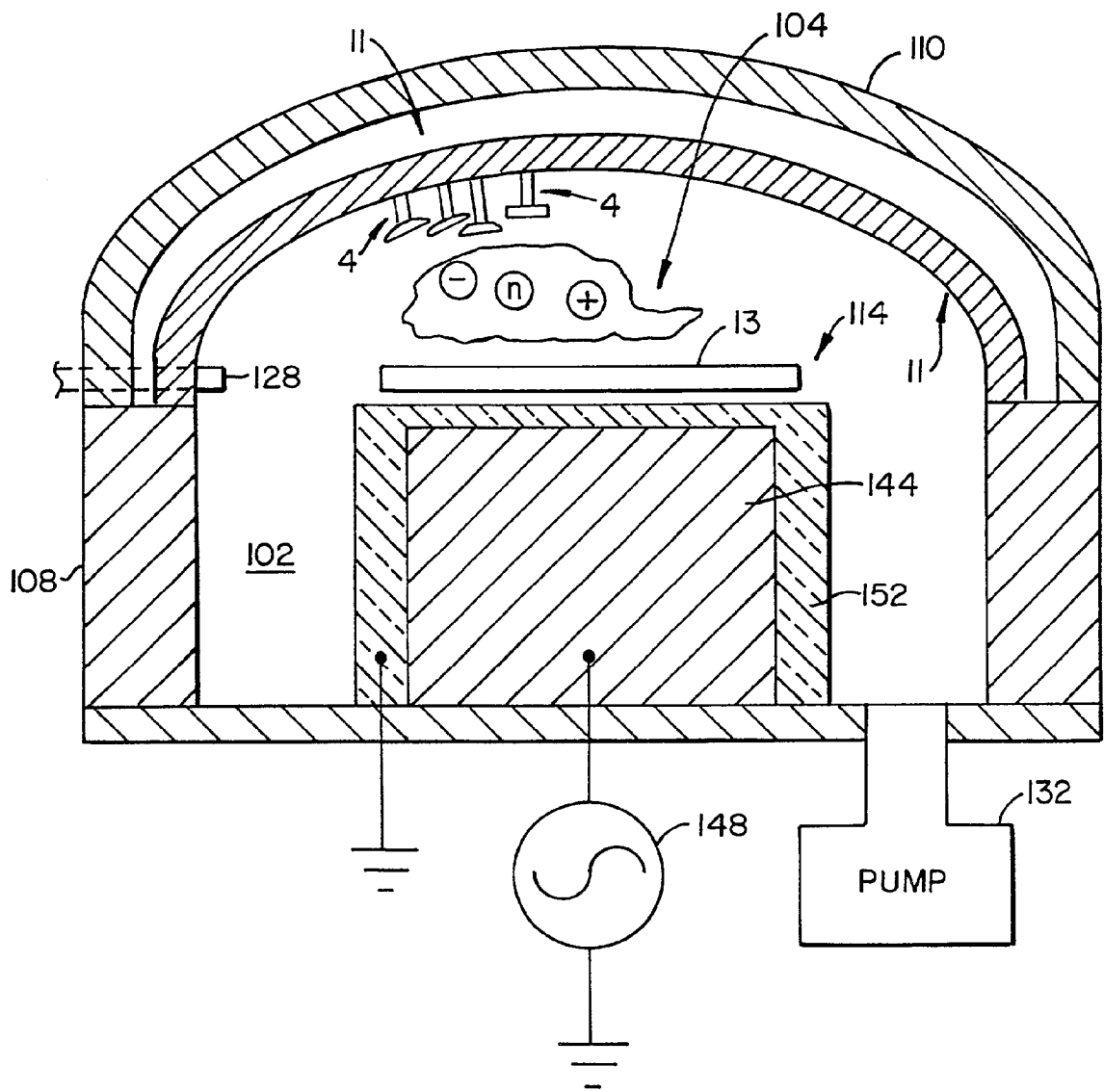


FIG. 14B.

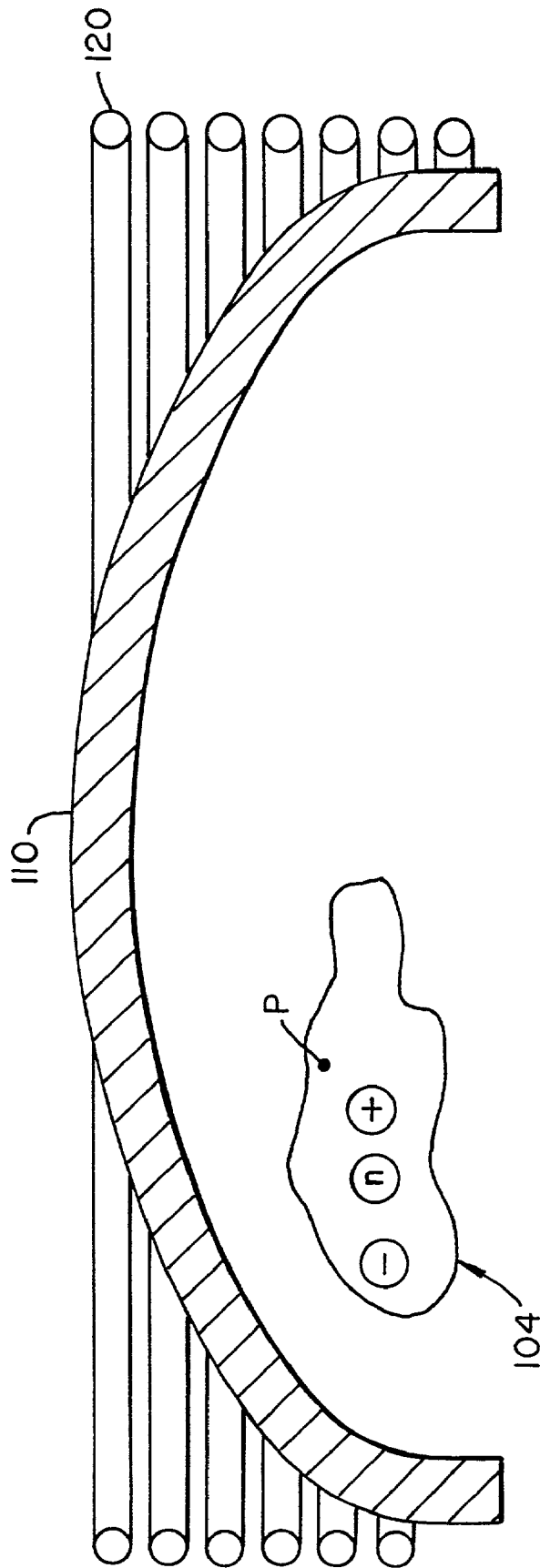


FIG. 15.

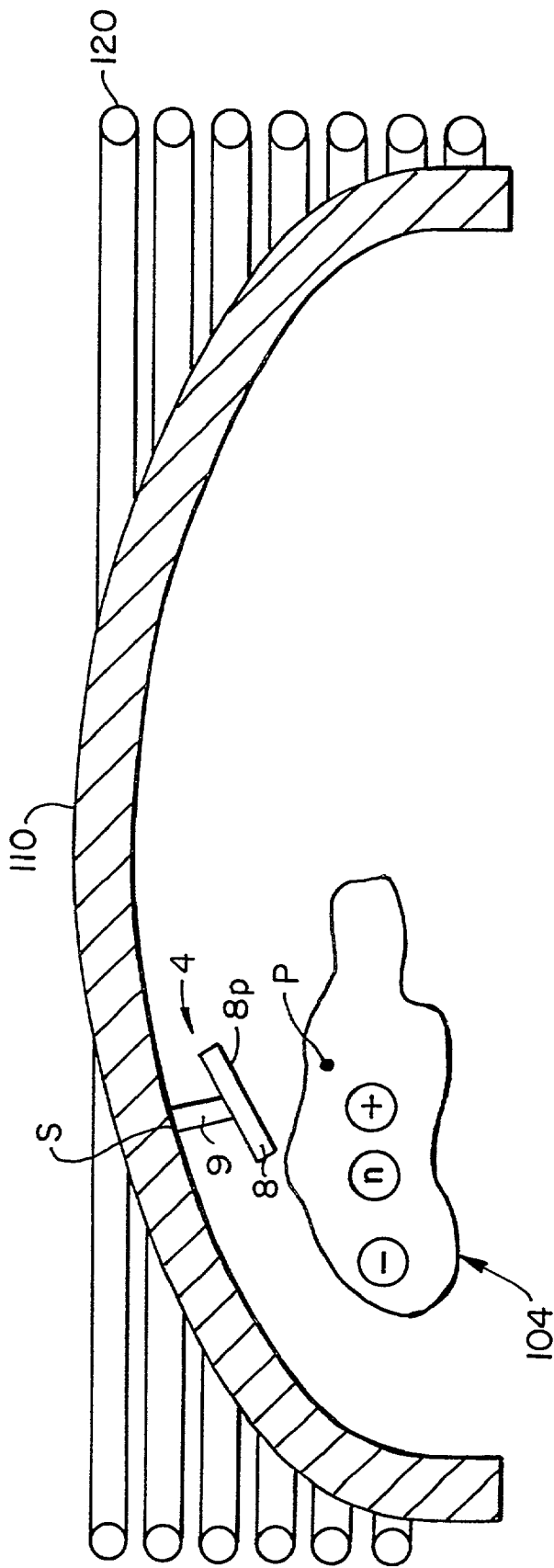


FIG. 16.

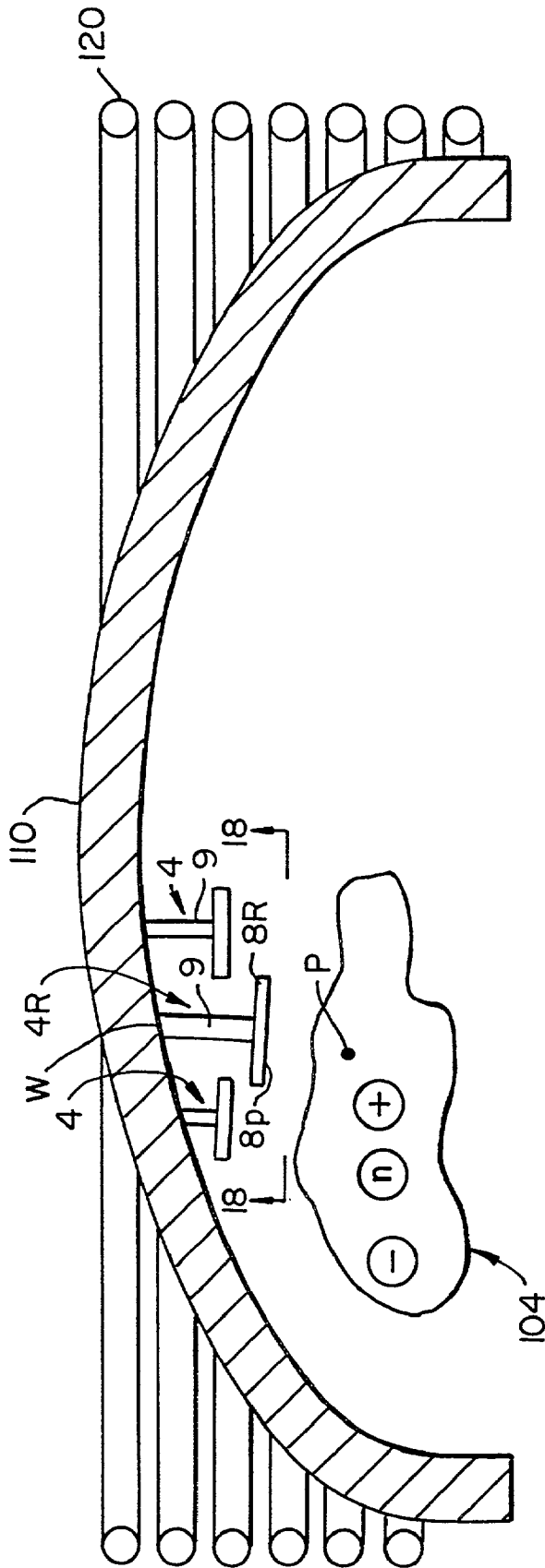
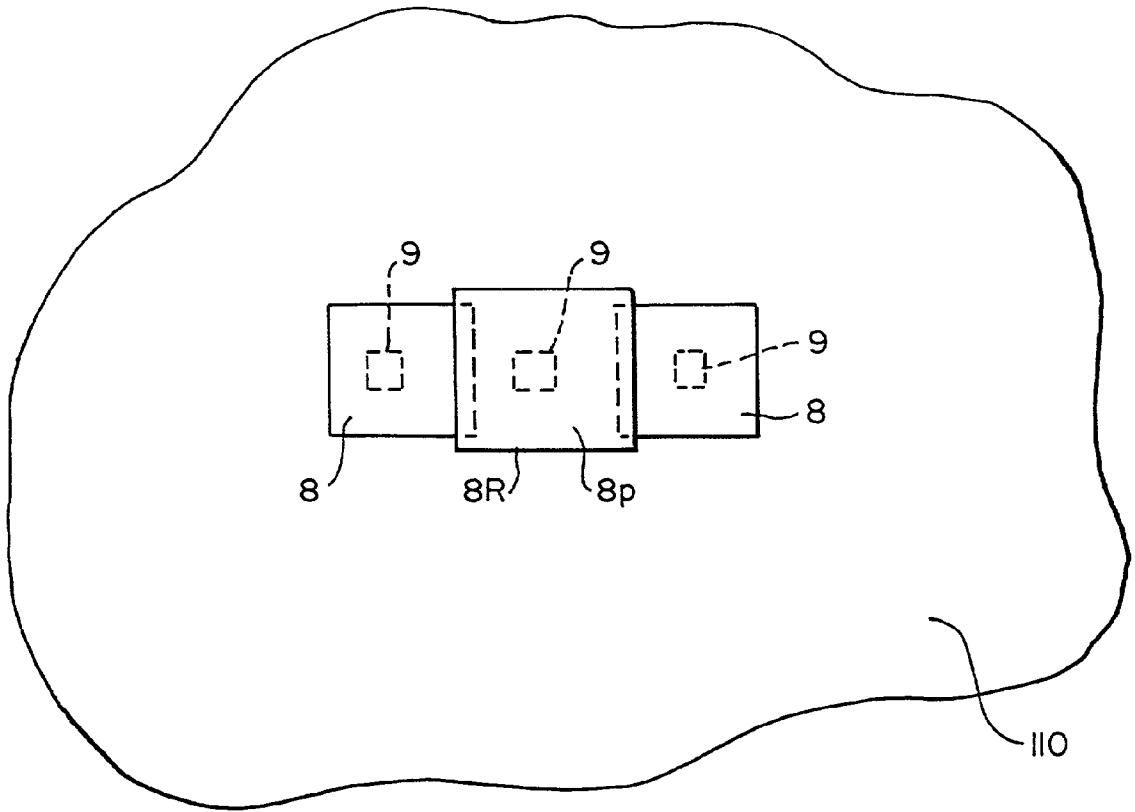


FIG. 17.



**FIG. 18.**

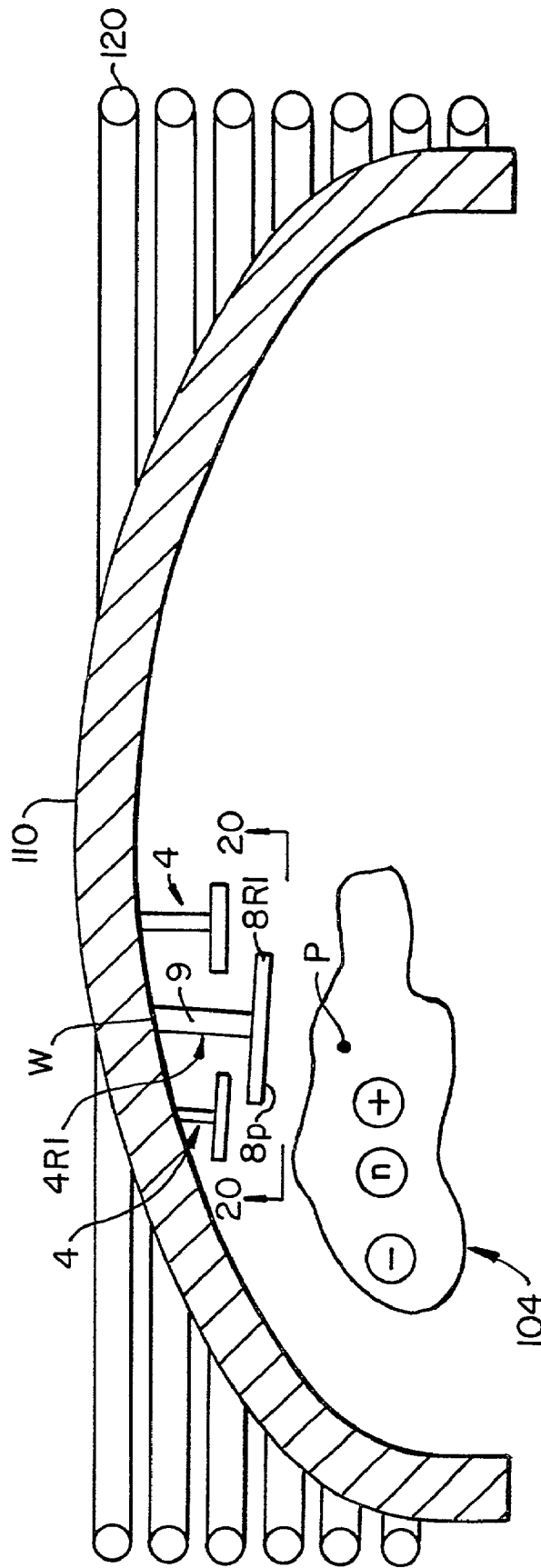
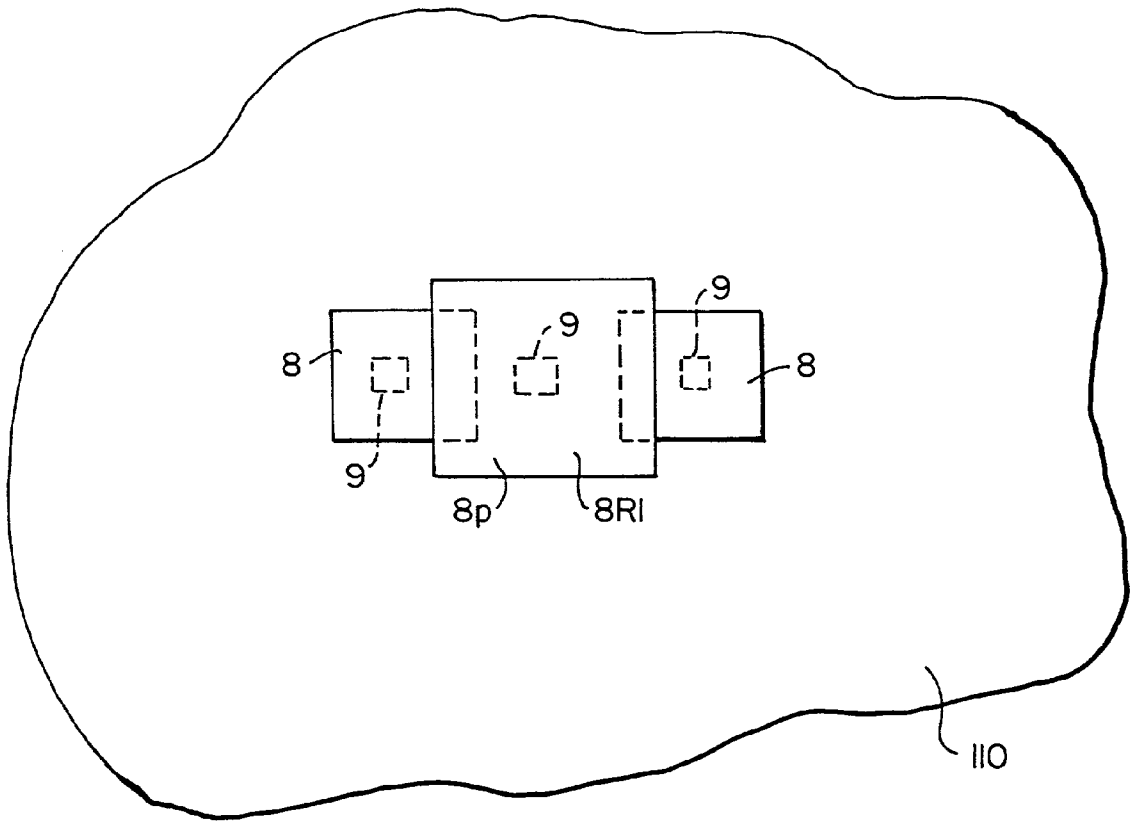


FIG. 19.



**FIG. 20.**

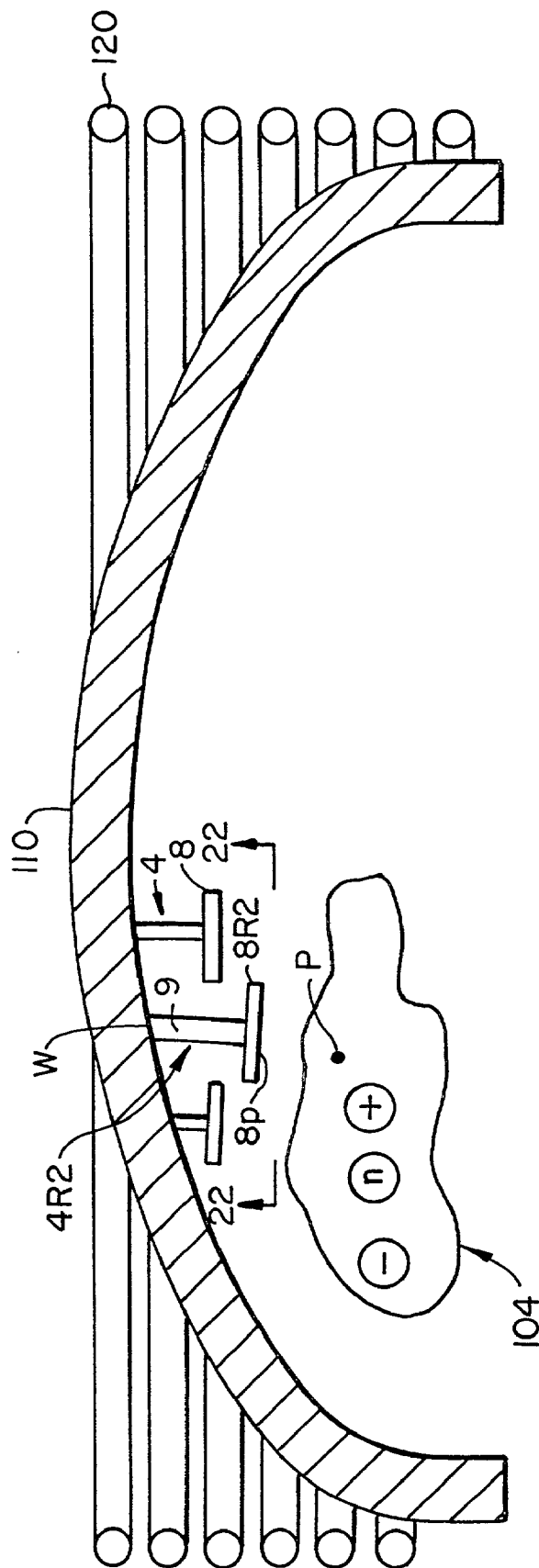
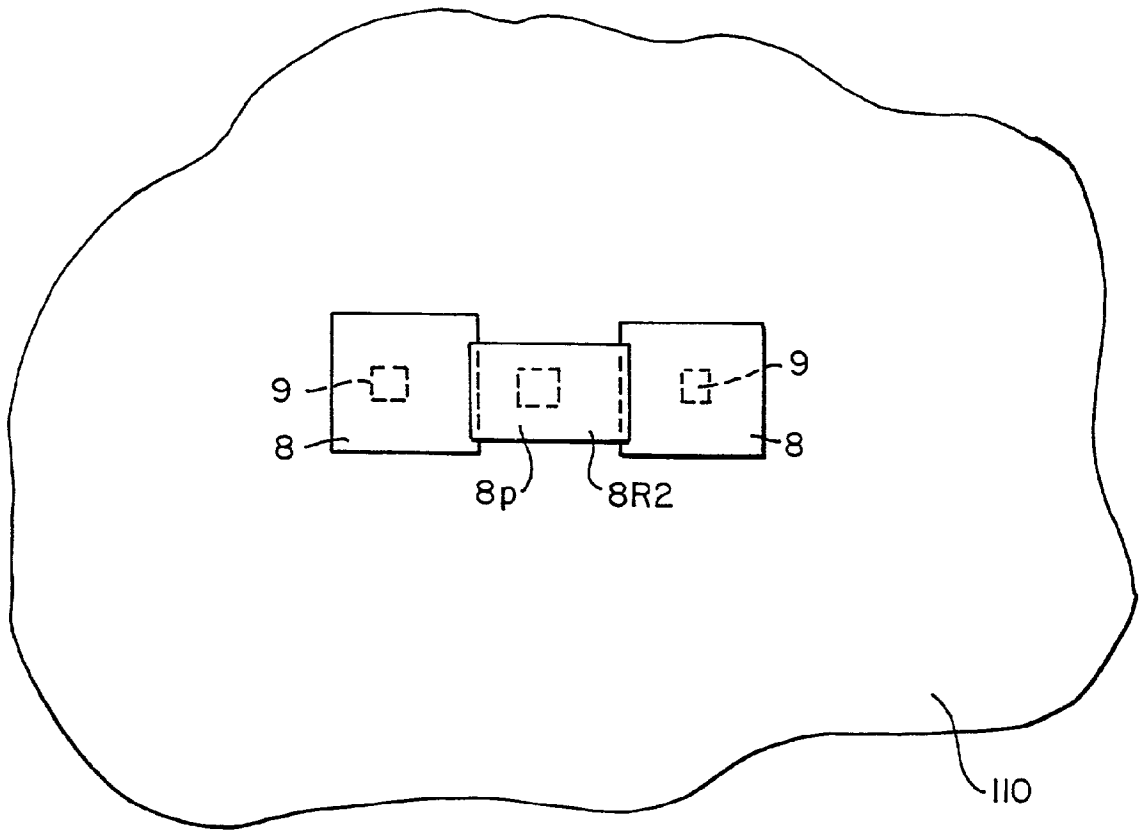


FIG. 21.



**FIG. 22.**

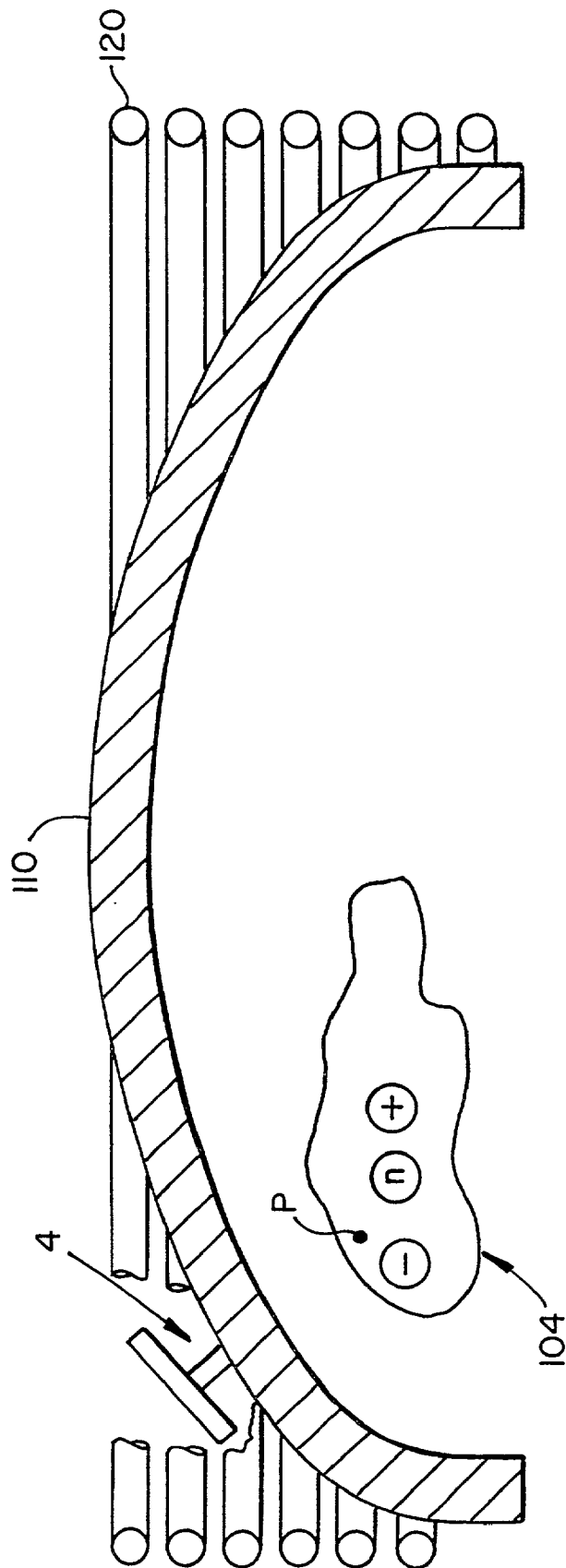


FIG. 23.

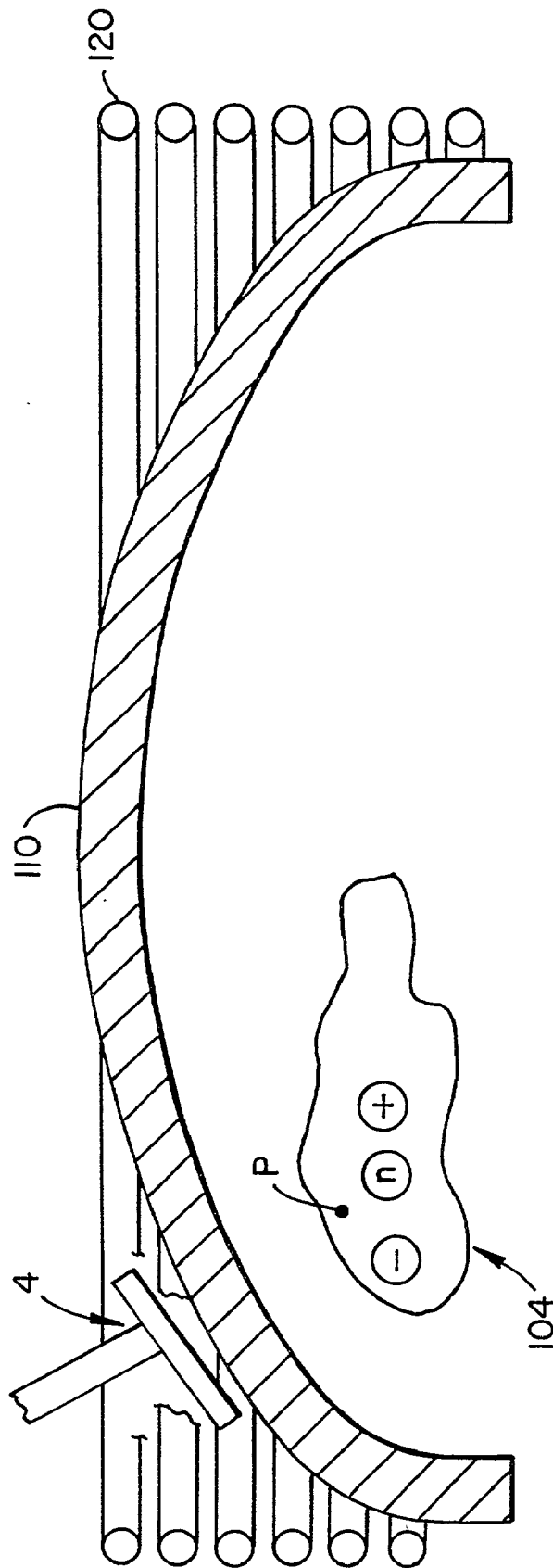
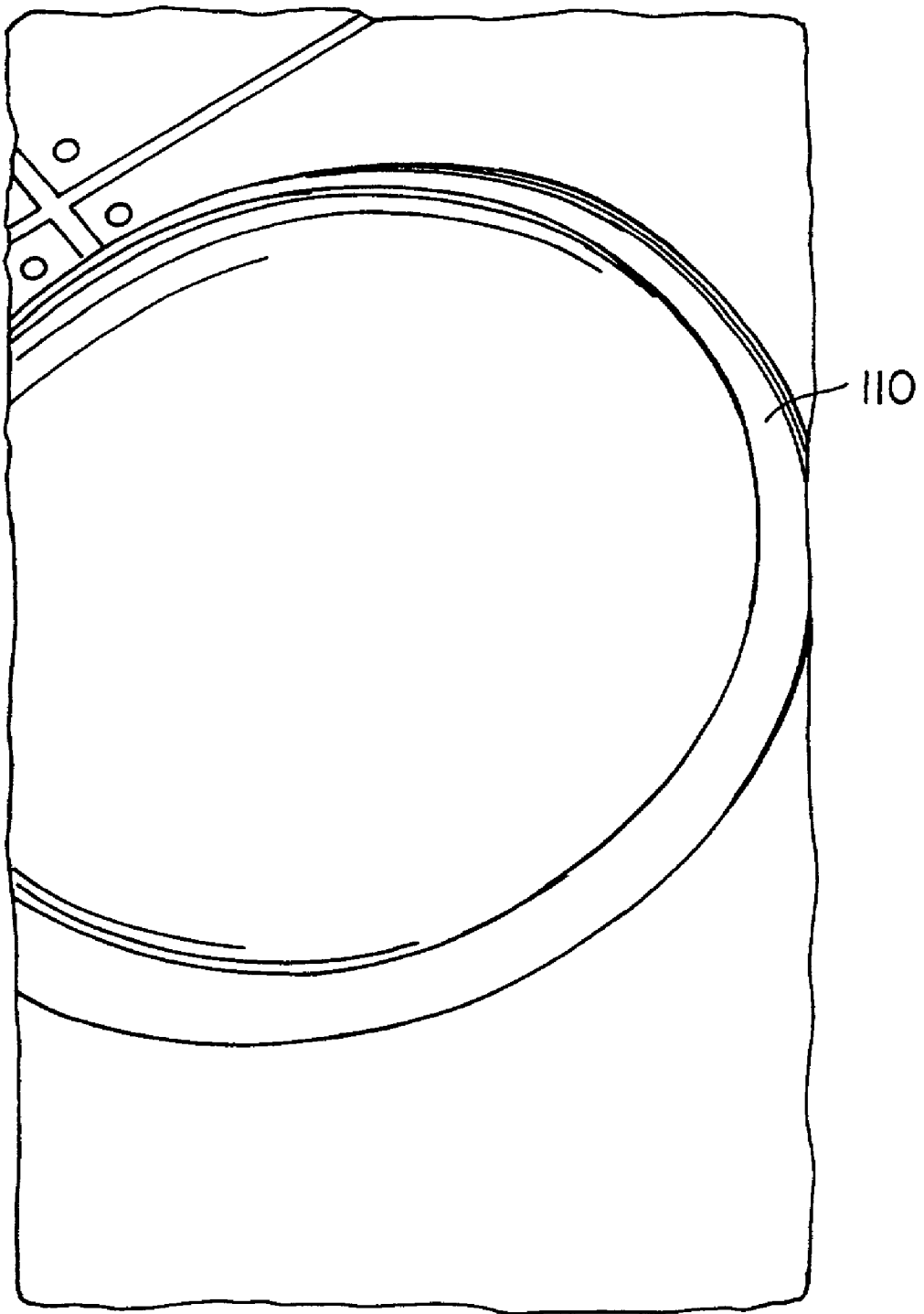
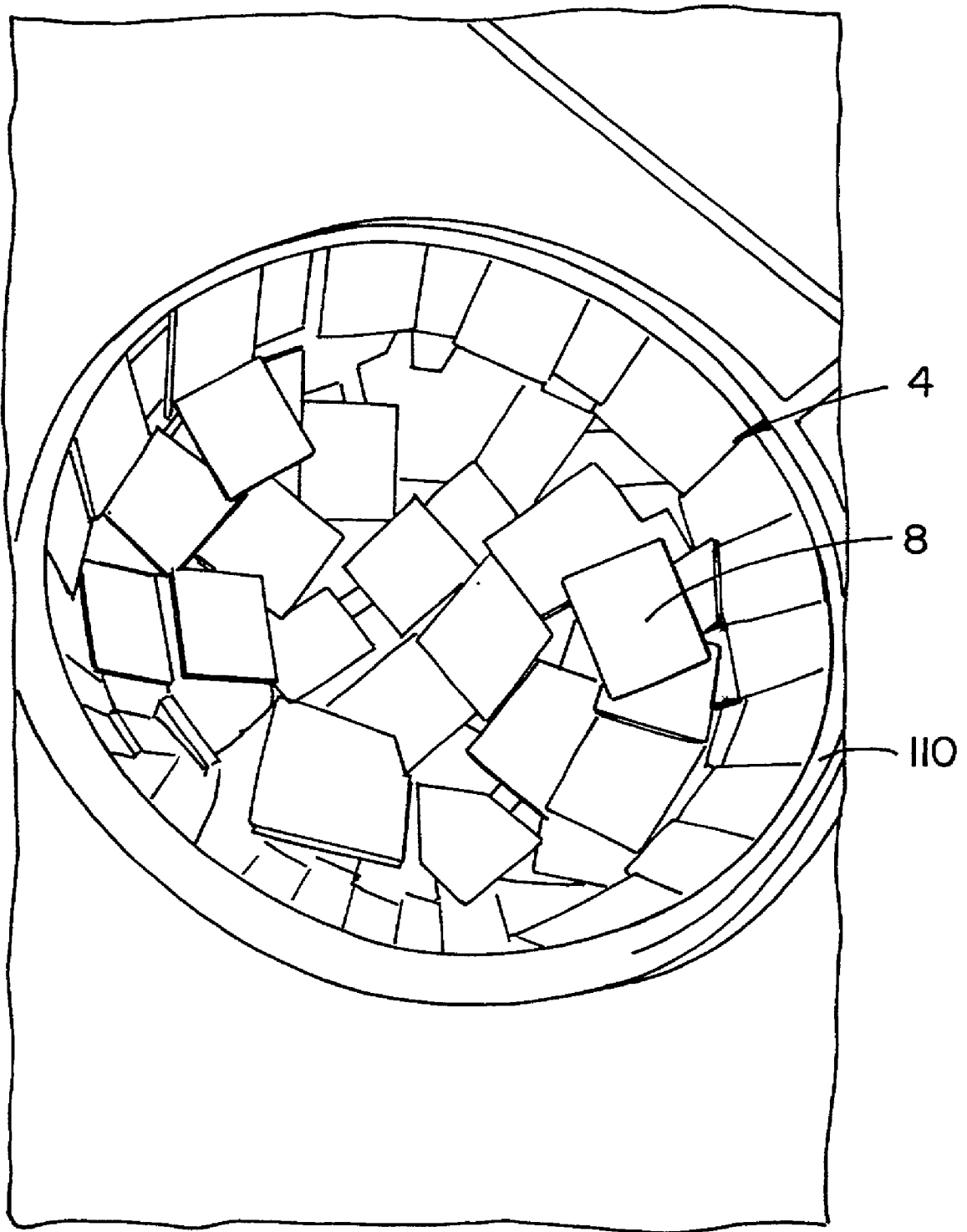


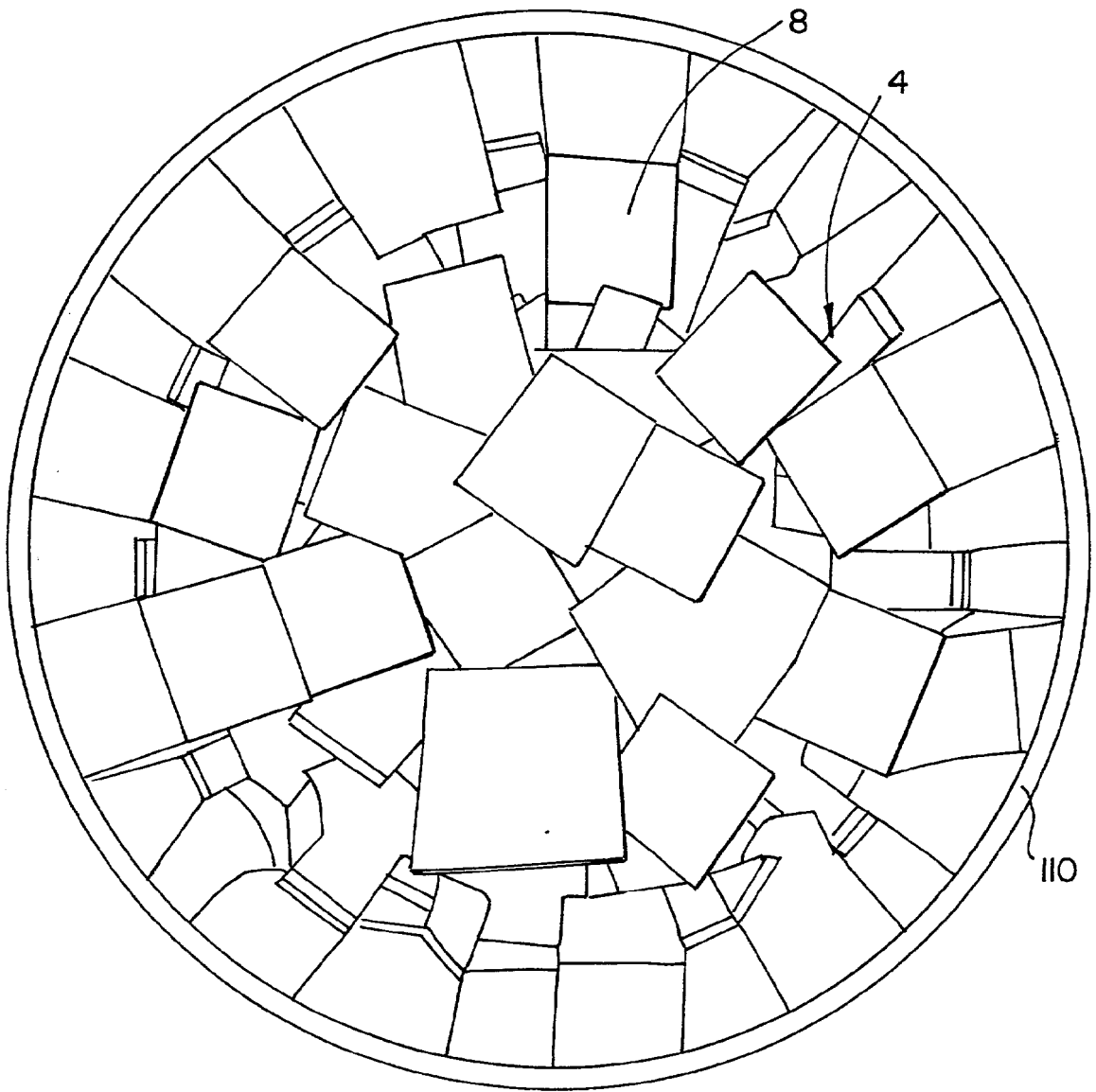
FIG. 24.



**FIG. 25.**



**FIG. 26A.**



*FIG. 26B.*

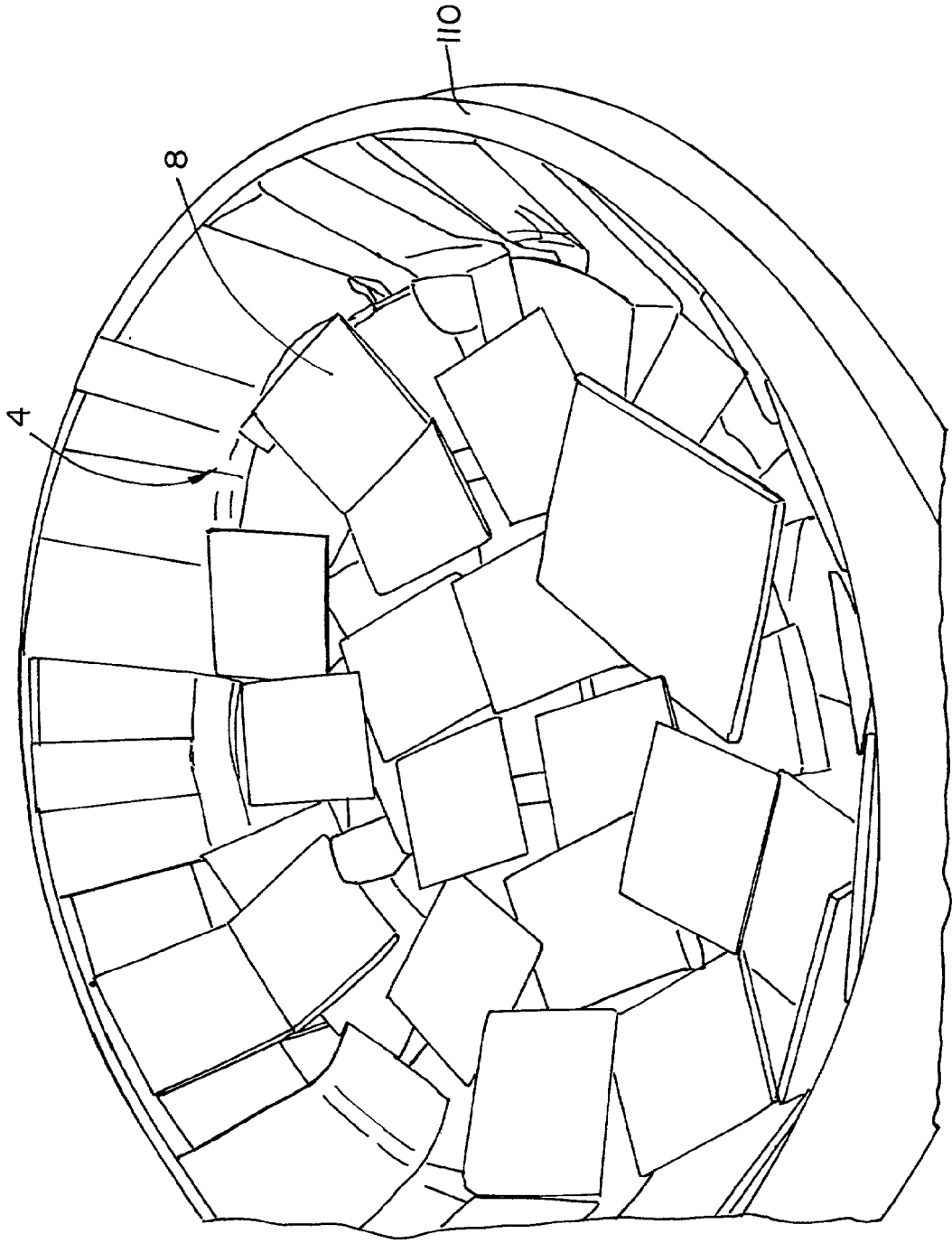


FIG. 26C.

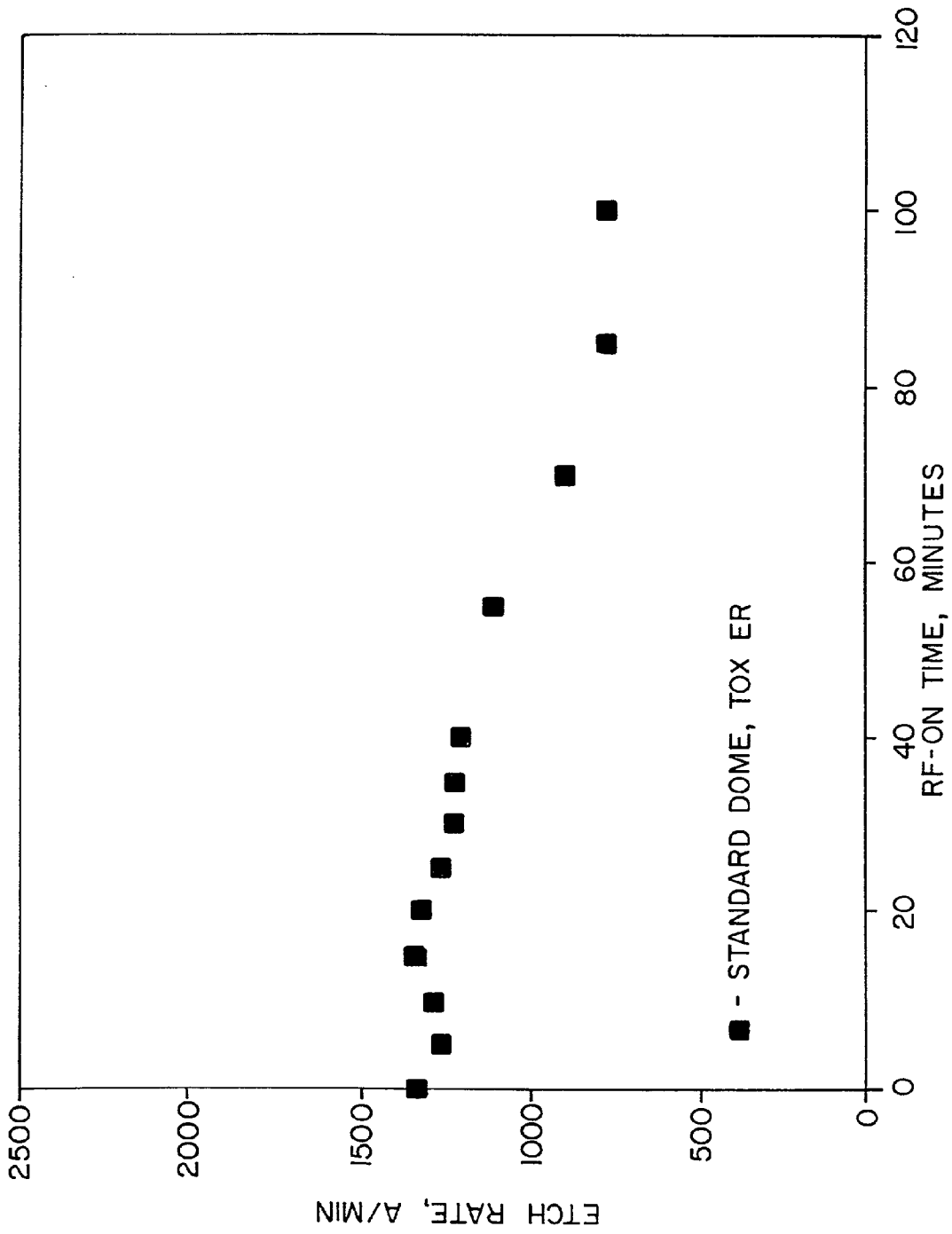


FIG. 27.

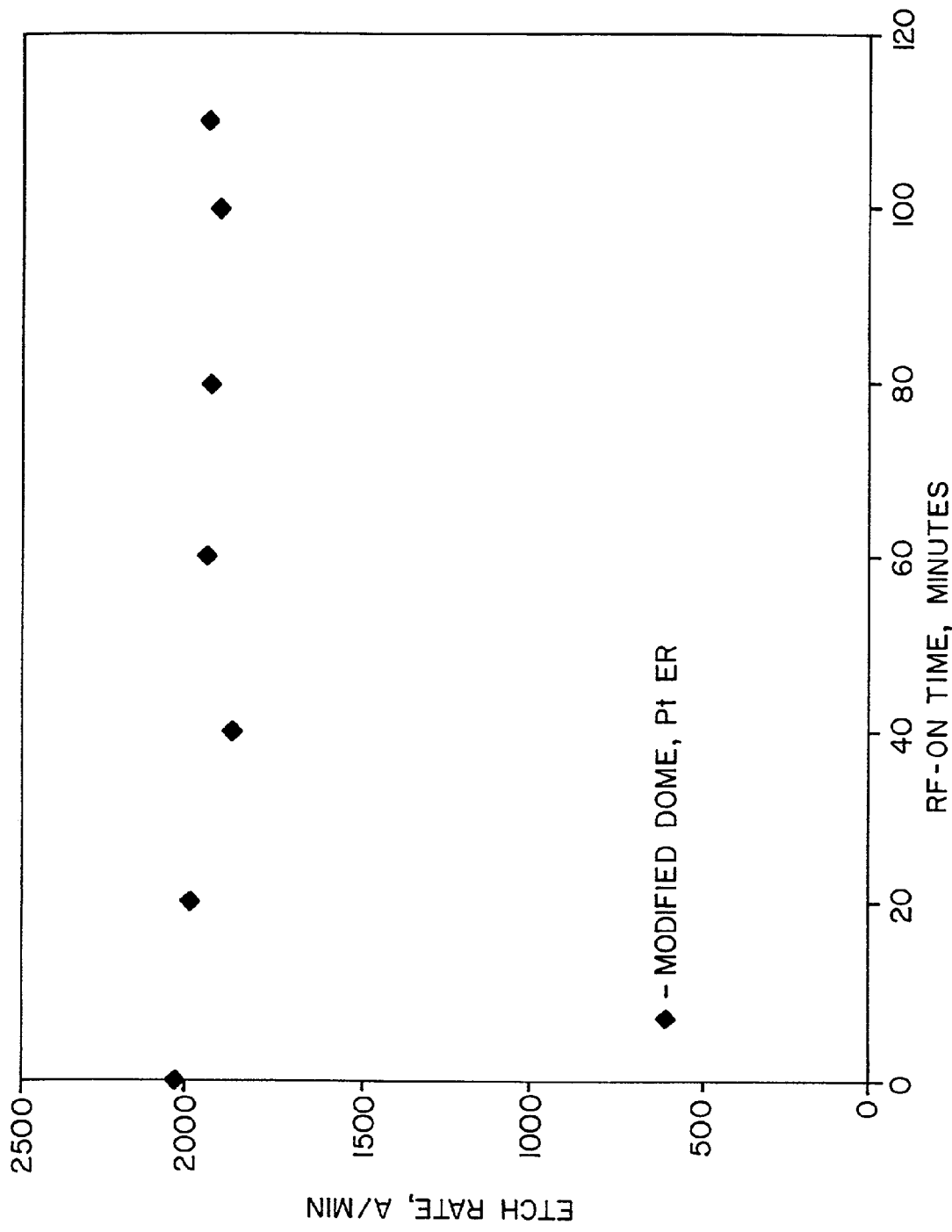


FIG. 28.

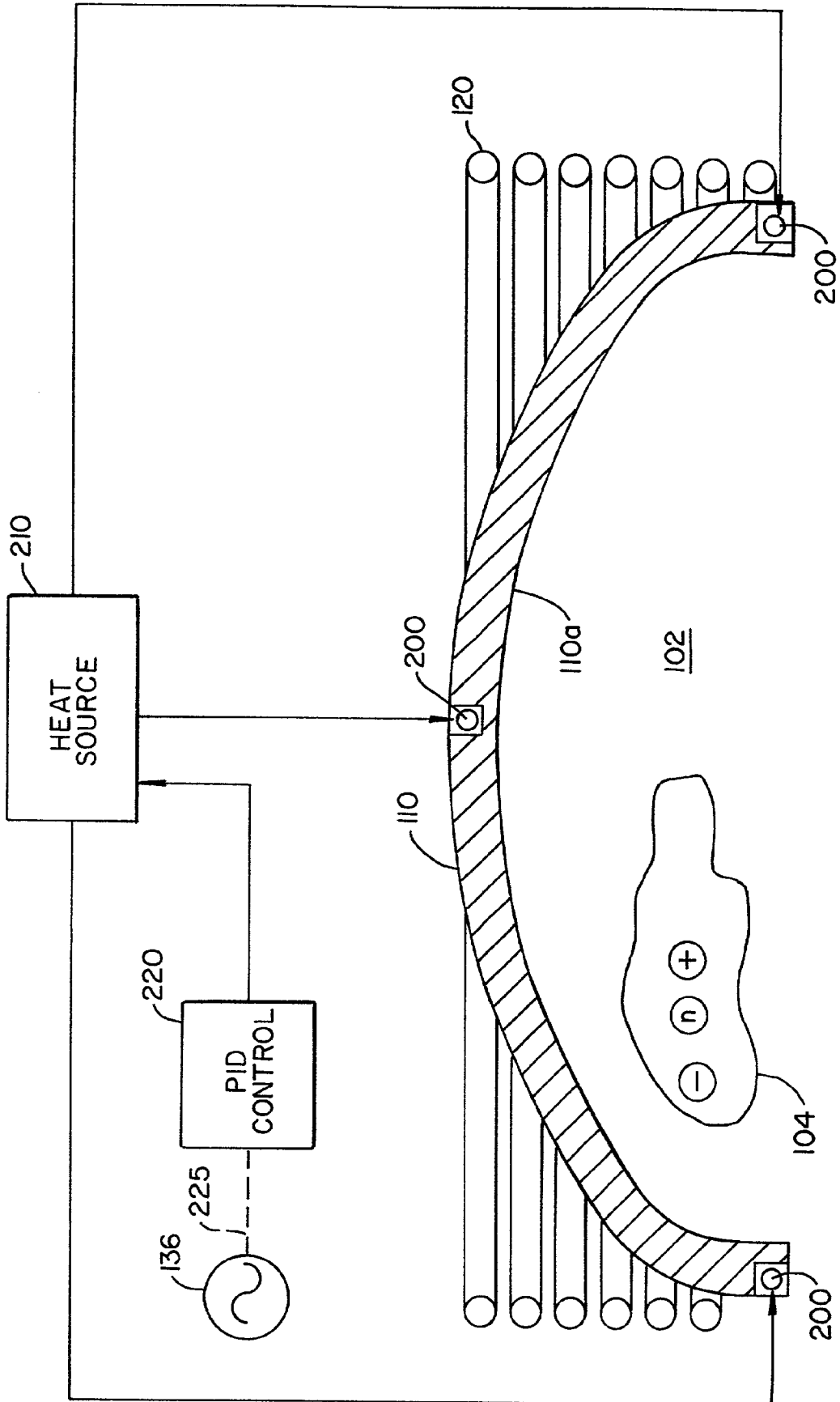


FIG. 29.

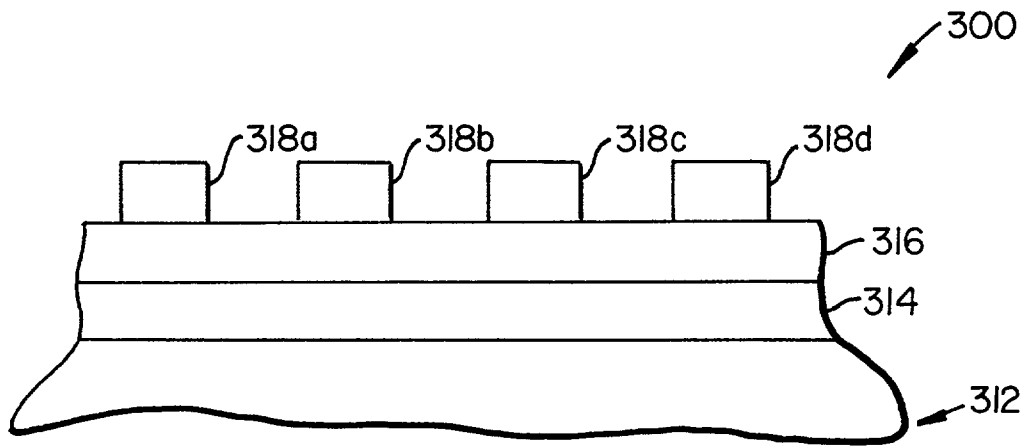


FIG. 30.

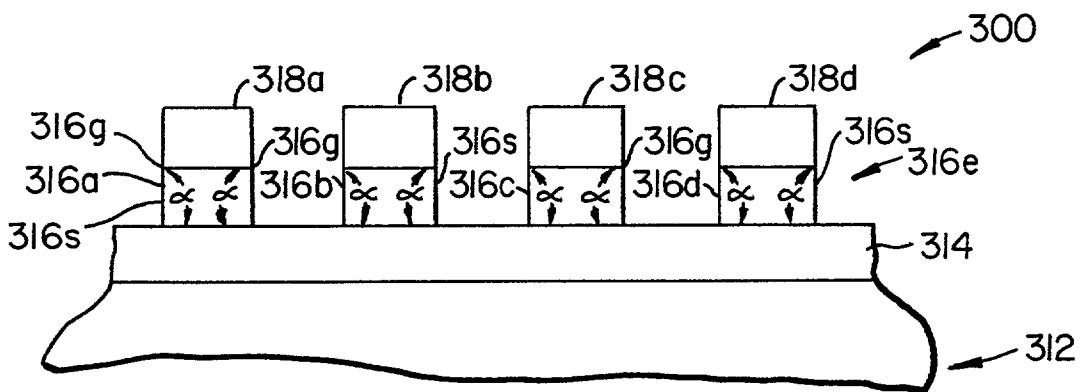


FIG. 31.

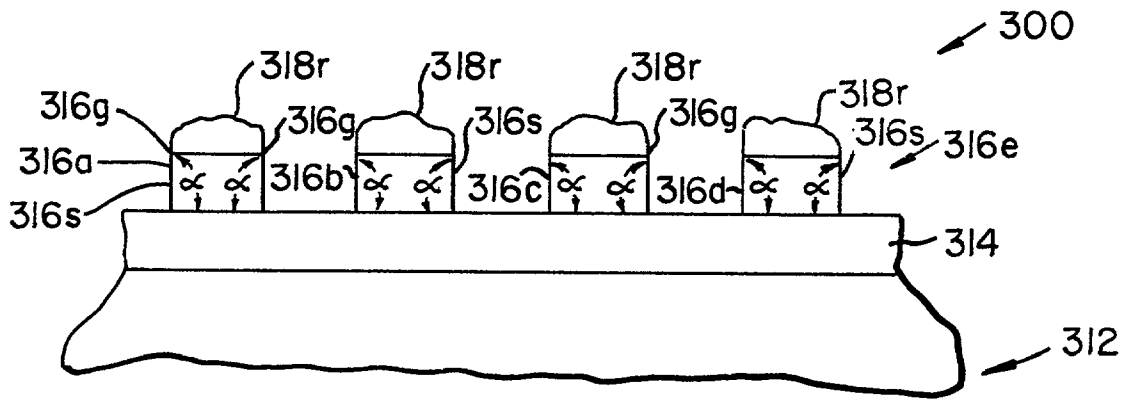


FIG. 32.

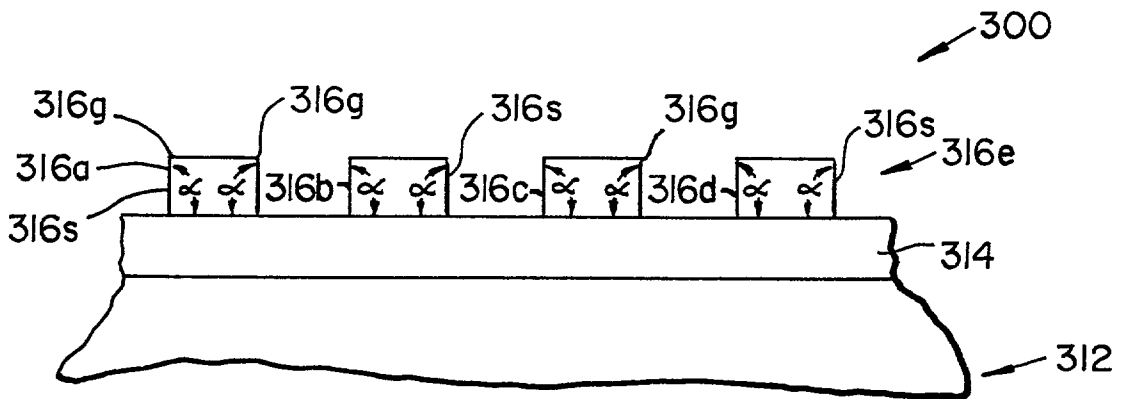


FIG. 33.

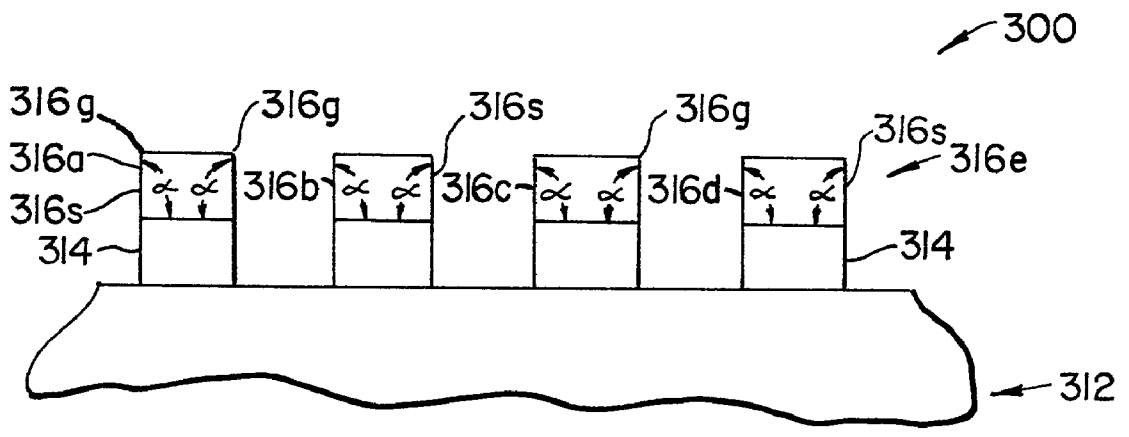


FIG. 34.

## METHOD FOR ALLOWING A STABLE POWER TRANSMISSION INTO A PLASMA PROCESSING CHAMBER

[0001] This is a continuation-in-part application of copending application entitled "An Apparatus and Method for Allowing a Stable Power Transmission into a Plasma Processing Chamber" having Ser. No. 08/920,283 and filed Aug. 26, 1997.

### BACKGROUND OF THE INVENTION

[0002] 1. Field of the Invention

[0003] This invention relates to an apparatus and method for processing (e.g., etching, chemical or physical vapor deposition, etc.) a substrate in a chamber containing a plasma. More specifically, this invention provides an apparatus and method for plasma processing of a semiconductor wafer. This invention allows a generally stable processing power (e.g., radio frequency (RF) processing power) to pass through a dielectric member and into a chamber of a plasma processing apparatus such that an essentially stable and uniform processing (e.g., etch rate) on semiconductor wafers may be maintained over a desired period of time.

[0004] 2. Description of the Prior Art

[0005] It is well known that various magnetically enhanced radio frequency (RF) diodes and triodes have been developed to improve performance of plasma reactors. As mentioned in an article entitled "Design of High-Density Plasma Sources" by Lieberman et al from Volume 18 of "Physics of Thin Films", copyright 1994 by Academic Press Inc. of San Diego, Calif., these include by way of example only, the Applied Materials AMT-5000 magnetically enhanced reactive ion etcher and the Microelectronics Center of North Carolina's split cathode RF magnetron. Magnetically enhanced reaction ion etchers (MERIE) apply a dc magnetic field of 50-100 Gauss (G) parallel to the powered electrode which supports a semiconductor wafer. The dc magnetic field enhances plasma confinement, resulting in a reduced sheath voltage and an increased plasma density when the magnetic field is applied. However, the plasma generated in MERIE systems is strongly nonuniform both radially and azimuthally. It is well known that in order to increase process uniformity, at least azimuthally, the magnetic field is rotated in the plane of the semiconductor wafer at a certain frequency, e.g., 0.5 Hz. While this is an improvement, MERIE systems still do not have the desired uniformity and high density in the generated plasma, which may limit the applicability of MERIE systems to next-generation, sub-micron device fabrication.

[0006] The limitations of RF diodes and triodes and their magnetically enhanced variants have led to the development of reactors operating at low pressures with high-efficiency plasma sources. These reactors can generate a higher density plasma and have a common feature in that processing power (e.g., RF power and/or microwave power) is coupled to the plasma across a dielectric window, rather than by direct connection to an electrode in the plasma, such as for an RF diode. Another common feature of these reactors is that the electrode upon which the wafer is placed can be independently driven by a capacitively coupled RF source. Therefore, independent control of the ion/radical fluxes through the source power and the ion bombarding energy through the wafer electrode power is possible.

[0007] While the limitations of RF diodes and triodes and their magnetically enhanced variants have motivated the development of high-density plasma reactors with low pressures, high fluxes, and controllable ion energies, these developed high-density plasma reactors have a number of challenges. One challenge is the inability of high-density plasma reactors to achieve the required process uniformity over 200-300 mm wafer diameters. High density sources are typically cylindrical systems with length-to-diameter usually exceeding unity. In such cylindrical systems plasma formation and transport is inherently radially nonuniform.

[0008] Another challenge is that the deposition of materials on the dielectric window during etching of semiconductor wafers in a process chamber has necessitated frequent and costly reactor cleaning cycles. This is especially true when metals, such as platinum, copper, aluminum, titanium etc., are etched or deposited in the production of integrated circuit (IC) devices. After a metal layer on a substrate has been etched or deposited for a period of time, the etch or deposit rate on the metal may decrease. The dropping in metal etch or deposit rate is due to the build up of conductive by-products deposited on the dielectric window. Such deposited conductive by-products behave as a Faraday shield to reduce the efficiency of rf energy transmission into the plasma by blocking the rf energy transmission through the dielectric window. Thus, there is no stable power transmission into the plasma processing chamber; and there is no efficient power transfer across dielectric windows over a wide operating range of plasma parameters.

[0009] Therefore, what is needed and what has been invented is a method for adjusting the density of plasma in a plasma processing chamber in proximity to a certain situs on a surface (i.e., an inside or outside surface) of the dielectric window. What is further needed and what has been invented is an assembly for allowing stable power transmission into a plasma processing chamber over a long period of time during processing of a substrate (i.e., semiconductor wafer) contained within the plasma processing chamber. The substrate supports a metal layer which is etched or deposited when processing power (e.g., RF power) is passed through a dielectric window and into a processing chamber containing the substrate and a plasma of the processing gas.

### SUMMARY OF THE INVENTION

[0010] The present invention accomplishes its desired objects by broadly providing an assembly for allowing stable power transmission into a plasma processing chamber comprising a member (i.e., a dielectric member consisting of a generally non-conductive material); and a means, coupled to the member, for preventing the deposition of materials on the dielectric member from becoming generally continuous during processing (e.g., etching, chemical vapor deposition, physical vapor deposition, etc.) of a substrate in a chamber containing a plasma of a processing gas. The dielectric member (e.g., a dielectric window) preferably possesses a dome-shaped configuration and may be formed from any non-conductive material such as ceramic. In one embodiment of the invention the means for preventing the deposition of materials on the member from becoming generally continuous during processing of a substrate in a chamber containing a plasma comprises a means, coupled to the dielectric member, for receiving and supporting the deposition of materials at a location spaced from the dielectric

member. The means for receiving and supporting the deposition of material at a location spaced from the dielectric member comprises at least one deposition support assembly secured to the dielectric member for receiving and supporting the deposition of materials during processing of a substrate in a chamber having a controlled environment and containing a plasma of a processing gas. The at least one deposition support assembly preferably comprises at least one deposition support member coupled to an inside surface of the dielectric member, more preferably the at least one deposition support member comprises a plurality of deposition supports and a plurality of brace members secured to the deposition supports and to the dielectric member to position the deposition supports in a spaced relationship with respect to the dielectric member. The plurality of deposition support members includes a plurality of overlapping and spaced deposition support members. The brace members vary in length such that at least two contiguous deposition support members include an overlapping and spaced relationship with respect to each other.

**[0011]** The material deposition support assembly including the deposition support members and the brace members may be manufactured from any suitable material including metal, plastic, non-conductive materials such as rubber, etc. Therefore, the material deposition support assembly comprises a material selected from the group consisting of a generally nonconductive material, a generally conductive material, and mixtures thereof. More specifically, the deposition support members and the brace members may each comprise a material selected from the group consisting of a generally nonconductive material, a generally conductive material, and mixtures thereof. A deposit of a material is supported by the material deposition support assembly including the deposition support members. The deposit of material is by-products from processing substrates in a chamber having a controlled environment and containing a plasma of a processing gas. The deposit of material would typically be an element or compound selected from the group consisting of metal, metal oxide, metal nitride, and mixtures thereof; and the metal would typically be a metal selected from the group consisting of platinum, copper, aluminum, titanium, ruthenium, iridium and mixtures thereof. In an alternative embodiment of the invention an assembly, preferably a metal assembly, may be situated in proximity to a certain situs on an outside surface of the dielectric member for interfering (e.g., diverting, absorbing, disrupting, etc.) with processing power before it passes through the dielectric member in order to adjust the density of the plasma of the processing gas at a location within a processing chamber. The metal assembly may be secured to an outside surface of the dielectric member, or if desired the metal assembly may be spaced from the certain situs including being supported by a structure other than the dielectric member. The metal assembly functions as a shield, diverter or absorber to selectively block, divert or absorb some of the processing power before it passes through the dielectric member.

**[0012]** The present invention further accomplishes its desired objects by broadly providing a plasma reactor for processing (e.g., etching, chemical vapor deposition, physical vapor deposition, etc.) substrates comprising a reactor chamber including a chamber wall and a dielectric window supported by the chamber wall. In one embodiment of the present invention, a plurality of deposition support members

is coupled to an inside surface of the dielectric window for receiving and supporting a deposition of materials during processing of substrates. In another embodiment of the present invention, a liner assembly is supported by the chamber wall and has a plurality of the deposition support members coupled thereto for receiving and supporting the deposition of the materials. A pedestal is disposed in the reactor chamber for supporting substrates therein. The plasma reactor also includes a processing power source and a processing gas-introducing assembly engaged to the reactor chamber for introducing a processing gas into the reactor chamber. A processing power-transmitting member is disposed in proximity to the reactor chamber and is connected to the processing power source for transmitting power into the interior of the reactor to aid in sustaining a plasma from a processing gas within the reactor chamber. The deposition support members are overlapping and spaced. The processing power source may be any suitable processing power source, preferably one or more selected from a microwave power source, a magnetron power source, and an RF power source. The processing power-transmitting member may be any suitable processing power-transmitting member such as a coiled inductor and/or an antenna.

**[0013]** In another embodiment of the plasma reactor for processing substrates, there is provided an inductively coupled RF plasma reactor for processing semiconductor wafers comprising a reactor chamber having a chamber wall and a dome-shaped ceiling supported by the chamber wall. A plurality of deposition support members is coupled to an inside surface of the dome-shaped ceiling for receiving and supporting the deposition of materials during processing of semiconductor wafers. A wafer pedestal is disposed in the reactor chamber for supporting semiconductor wafers in the reactor chamber. An inductively coupled RF power source is provided, and a means, engaged to the reactor chamber, is provided for introducing a processing gas into the reactor chamber. The inductively coupled RF plasma reactor also includes a coil inductor adjacent to the reactor chamber and connected to the RF power source and a bias RF source connected to the wafer pedestal. The means for introducing a processing gas (i.e., a processing gas-introducing assembly) may be any suitable means such as a high pressure gas cylinder/flow meter assembly communicating with an inlet in the chamber wall of the reactor chamber. The bias RF source is independent of the inductively coupled RF power source such that respective RF power levels applied to the coil inductor and to the wafer pedestal are independently adjustable.

**[0014]** The present invention also further accomplishes its desired objects by broadly providing a method for adjusting the density of plasma contained in a chamber wherein substrates are to be processed comprising the steps of:

**[0015]** a) providing a chamber containing a plasma processing gas for processing at least one substrate and including a chamber wall having a dielectric member releasably engaged thereto;

**[0016]** b) introducing processing power through the dielectric member and into the chamber of step (a) to process at least one substrate in the plasma processing gas having a plasma density;

**[0017]** c) determining that the plasma density of step (b) for processing at least one substrate should be

- adjusted at a location in the chamber in proximity to a certain situs on an inside surface of the dielectric member;
- [0018] d) interrupting the introducing of processing power through the dielectric member and into the chamber;
- [0019] e) removing the dielectric member from engagement with the chamber wall of step (a);
- [0020] f) securing to said certain situs on the inside surface of the dielectric member of step (c) a material deposition support assembly for receiving and supporting a deposition of materials during processing of at least one substrate in the chamber;
- [0021] g) connecting the dielectric member of step (f) to the chamber wall for reengaging the chamber wall of step (e) with the dielectric member; and
- [0022] h) reintroducing processing power through the dielectric member of step (g) and into the chamber to process at least one substrate in the plasma processing gas having an adjusted plasma density.
- [0023] In another embodiment of the method for adjusting the density of plasma contained in a chamber wherein substrates are to be processed, there is provided the method as comprising the following steps:
- [0024] a) providing a chamber containing a plasma processing gas for processing at least one substrate and including a chamber wall having a dielectric member releasably engaged thereto with a plurality of material deposition support members coupled to an inside surface of the dielectric member for receiving and supporting a deposition of materials during processing of at least one substrate in the chamber;
- [0025] b) introducing processing power through the dielectric member and into the chamber of step (a) to process at least one substrate in the plasma processing gas having a plasma density and to commence the deposition of materials on the material deposition support members of step (a);
- [0026] c) determining that the plasma density of the plasma processing gas of step (b) should be adjusted at a location in the chamber in proximity to a particular material deposition support member having a surface area (e.g., a planar surface area, an arcuate surface area, etc.) and coupled to a certain situs on the inside surface of the dielectric member;
- [0027] d) interrupting the introducing of processing power through the dielectric member and into the chamber;
- [0028] e) removing the dielectric member from engagement with the chamber wall of step (a);
- [0029] f) removing the particular material deposition support member of step (c) from said certain situs on the inside surface of the dielectric member;
- [0030] g) securing a replacement material deposition support member to the certain situs on the inside surface of the dielectric member to replace the removed particular material deposition support member;
- [0031] h) connecting the dielectric member of step (g) to the chamber wall for reengaging the chamber wall with the dielectric member; and
- [0032] i) reintroducing processing power through the dielectric member of step (h) and into the chamber to process at least one substrate in the plasma processing gas having an adjusted plasma density at the step (c) location in the chamber.
- [0033] In the immediate foregoing method for adjusting the density of plasma, the replacement material deposition support member of step (g) has a surface area (e.g., a planar surface area, an arcuate surface area, etc.) that differs from the surface area of the particular material deposition support member of step (c). In one embodiment of the invention, the replacement material deposition support member of step (g) has a surface area that is larger than the surface area of the particular material deposition support member of step (c) such that the adjusted plasma density of step (i) is essentially at the step (c) location in the chamber and is less than the step (c) plasma density. In another embodiment of the invention, the replacement material deposition support member of step (g) has a surface area that is smaller than the surface area of the particular material deposition support member of step (c) such that the adjusted plasma density of step (i) is at the step (c) location in the chamber and is greater than the step (c) plasma density. The method for adjusting the density of plasma further includes removing, after the reintroducing step (i), the dielectric member of step (h); and cleaning the deposit of the material from the material deposition support members.
- [0034] In yet another embodiment of the immediate foregoing method for adjusting the density of plasma, there is provided the method as comprising the following steps:
- [0035] a) providing a chamber containing a plasma processing gas for processing at least one substrate and including a chamber wall having a dielectric member releasably engaged thereto;
- [0036] b) introducing processing power through the dielectric member and into the chamber of step (a) to process at least one substrate in the plasma processing gas having a plasma density;
- [0037] c) determining that the plasma density of step (b) for processing at least one substrate should be adjusted at a location in the chamber in proximity to a certain situs on an outside surface of the dielectric member;
- [0038] d) interrupting the introducing of processing power through the dielectric member and into the chamber;
- [0039] e) situating a processing power-interfering assembly in proximity to said certain situs on the outside surface of the dielectric member of step (c) for engaging and interfering with processing power at the step (c) location in the chamber during processing of at least one substrate in the chamber; and
- [0040] f) reintroducing processing power, after said processing power has engaged and been interfered with by the assembly of step (e), through the dielectric member and into the chamber to process at least

one substrate in the plasma processing gas having an adjusted plasma density at the step (c) location in the chamber.

[0041] The present invention yet also further accomplishes its desired objects by providing a method for depositing a material on a plurality of material deposition support members during processing of at least one substrate in a chamber containing a plasma processing gas comprising the steps of:

[0042] a) providing a chamber containing at least one substrate and a plasma processing gas for processing at least one substrate and including a chamber wall and having a dielectric member releasably engaged thereto with a plurality of overlapping and spaced material deposition support members coupled to an inside surface of the dielectric member for receiving and supporting a deposition of a material during processing of the at least one substrate in the chamber; and

[0043] b) introducing processing power through the dielectric member and into the chamber of step (a) to process the at least one substrate in the plasma processing gas and to deposit a material on said material deposition support members.

[0044] The immediate foregoing method for depositing a material on a plurality of material deposition support members may additionally comprise interrupting the introducing of processing power through the dielectric member and into the chamber; removing the dielectric member from engagement with the chamber wall of step (a); and removing the deposit of the material from the material deposition support members.

[0045] The present invention also accomplishes its desired objects by broadly providing a method of processing (e.g., etching or depositing) a metal layer on a substrate comprising the steps of:

[0046] a) providing a substrate which receives and/or supports a metal layer;

[0047] b) disposing the substrate in a chamber including a chamber wall, a dielectric member releasably engaged to the chamber wall, and a plurality of overlapping and spaced material deposition support members coupled to an inside surface of the dielectric member for receiving and supporting a deposition of a material during processing of the metal layer on the substrate;

[0048] c) introducing a processing gas into the chamber of step (b); and

[0049] d) introducing processing power through the dielectric member and into the chamber of step (b) to process the metal layer on the substrate in a plasma of the processing gas and to deposit a material on the material deposition support members.

[0050] In another preferred embodiment of the present invention, a method is provided for processing a metal layer on a substrate comprising the steps of:

[0051] a) providing a substrate;

[0052] b) disposing the substrate in a chamber including a chamber wall and a dielectric member supported by the chamber wall;

[0053] c) introducing a processing gas into the chamber of step (b);

[0054] d) passing processing power through the dielectric member and into the chamber of step (b) for processing a metal layer on the substrate in a plasma of the processing gas and to produce processing power-blocking materials which are capable of depositing on the dielectric member and reducing the efficiency of processing power passing through the dielectric member and into the plasma within the chamber; and

[0055] e) essentially preventing the processing power-blocking materials from depositing on the dielectric member.

[0056] In the immediate foregoing method for processing a metal layer on a substrate, the essentially preventing step (e) comprises heating, preferably to a temperature greater than about 150° C., a surface of the dielectric member to a temperature which essentially prevents the processing power-blocking materials (e.g., electrically conductive products) from depositing on the surface of the dielectric member. The processing power-blocking materials include a capability of forming on a surface of the dielectric member a deposit whose conductivity increases as the thickness of the deposit decreases, and as the temperature of the dielectric member increases.

[0057] In yet another preferred embodiment of the present invention, a method is provided for preventing a deposit of materials whose conductivity increases as the thickness of the deposit decreases comprising:

[0058] a) providing a chamber including a chamber wall supporting a dielectric member and containing at least one substrate and a plasma processing gas for processing at least one substrate;

[0059] b) introducing processing power through a dielectric member and into the chamber for processing the substrate and producing materials which are capable of forming a deposit on a surface of the dielectric member wherein the deposit would include a conductivity which increases as the thickness of the deposit decreases, preferably a conductivity which increases as the thickness of the deposit decreases due to an increase in temperature of the surface of the dielectric member; and

[0060] c) heating the surface of the dielectric member to a temperature greater than about 150° C. to essentially prevent the produced materials from depositing on the surface of the dielectric member.

[0061] In still yet another preferred embodiment of the present invention, a method is provided for etching a platinum layer disposed on a substrate comprising the steps of:

[0062] a) providing a substrate supporting a platinum layer;

[0063] b) disposing the substrate of step (a) in a chamber including a chamber wall supporting a dielectric member and containing a processing gas;

[0064] c) heating an interior surface of the dielectric member to a temperature to essentially prevent platinum by-products produced from etching the platinum layer in a plasma of the processing gas from forming a deposit on the interior surface of the dielectric member and reduce the efficiency of processing power passing through the dielectric member and into the plasma of the processing gas; and

[0065] d) etching the platinum layer in a plasma of the processing gas to produce an etched platinum layer and the platinum by-products of step (c) without any of the platinum by-products forming a deposit on the interior surface of the dielectric member.

[0066] It is therefore an object of the present invention to provide an assembly for allowing stable power transmission into a plasma processing chamber.

[0067] It is another object of the present invention to provide a plasma reactor for processing substrates.

[0068] It is also another object of the present invention to provide an inductively coupled RF plasma reactor for processing semiconductor wafers.

[0069] It is yet another object of the present invention to provide a method for adjusting the density of plasma contained in a chamber wherein substrates are to be processed.

[0070] It is also yet another object of the present invention to provide a method for depositing a material on a plurality of material deposition support members during processing of at least one substrate in a chamber containing a plasma processing gas.

[0071] It is yet a further object of the present invention to provide a method of processing a metal layer on a substrate.

[0072] These, together with the various ancillary objects and features which will become apparent to those skilled in the art as the following description proceeds, are attained by this novel assembly and method, a preferred embodiment thereof shown with reference to the accompanying drawings, by way of example only, wherein:

#### BRIEF DESCRIPTION OF THE DRAWINGS

[0073] FIG. 1 is a side elevational view of a dielectric member having a plurality of assemblies secured thereto for allowing stable power transmission into a plasma processing chamber;

[0074] FIG. 2 is a horizontal view taken in direction of the arrows and along the plane of line 2-2 in FIG. 1;

[0075] FIG. 2A is a partial vertical sectional view of a dome-shaped dielectric member having a deposit of material thereon, resulting from processing a substrate (e.g., a semiconductor wafer) in a chamber containing a plasma of a processing gas;

[0076] FIG. 3 is a side elevational view of another embodiment of a plurality of the assemblies for allowing stable power transmission into a plasma processing chamber, with the assemblies being coupled or secured to an inside surface of a dome-shaped dielectric member;

[0077] FIG. 4 is a horizontal view taken in direction of the arrows and along the plane of line 4-4 in FIG. 3;

[0078] FIG. 5 is another embodiment of a plurality of the assemblies for allowing stable power transmission into a plasma processing chamber, with the assemblies being coupled or secured to an inside surface of a dome-shaped dielectric member, and with the deposition support members of the assemblies supporting a deposit of a material (e.g., electrically conductive by-products resulting from processing a semi-conductor wafer in the plasma processing chamber) and with part of the inside surface of the dielectric member also having the deposit of material;

[0079] FIG. 6 is a horizontal view taken in direction of the arrows and along the plane of line 6-6 in FIG. 5, disclosing the deposit of material on the deposition support members of the assemblies in FIG. 5 and disclosing the deposit of material on the inside surface of the dielectric member which is not being shielded by any of the deposition support members;

[0080] FIG. 7 is a vertical sectional view taken in direction of the arrows and along the plane of line 7-7 in FIG. 5;

[0081] FIG. 8 is a schematic diagram of a prior art electron cyclotron resonance (ECR) source reactor;

[0082] FIG. 9 is a schematic diagram of a prior art helicon source reactor;

[0083] FIG. 10 is a schematic diagram of a prior art helical resonator reactor;

[0084] FIG. 11 is a schematic diagram of a prior art inductively coupled plasma reactor;

[0085] FIG. 12 is a simplified cut-away view of an inductively coupled RF plasma reactor having a dome-shaped dielectric ceiling which may support a plurality of the assemblies of the present invention for allowing stable power transmission to pass through the dome-shaped ceiling and into the plasma processing chamber;

[0086] FIG. 13 is a simplified cut-away view of another inductively coupled RF plasma with a dome-shaped dielectric ceiling whose inside surface may dependently support a plurality of the assemblies of the present invention for allowing stable power transmission to pass through the dome-shaped ceiling and into the plasma processing chamber;

[0087] FIG. 14A is a vertical sectional view of the dome-shaped dielectric ceiling of the inductively coupled RF plasma reactor of FIG. 12 with a plurality of the assemblies of the present invention attached to the inside surface of the dome-shaped dielectric ceiling for receiving and supporting a deposit of materials and for allowing stable power transmission to pass through the dome-shaped dielectric ceiling and into a plasma processing chamber of the inductively coupled RF plasma reactor;

[0088] FIG. 14B is a partial vertical sectional view of a plasma reactor having a dome-shaped dielectric ceiling and a perforated liner assembly, both supported by a chamber wall of the plasma reactor and having a plurality of the assemblies of the present invention attached to the inside surface of the perforated liner assembly for receiving and supporting a deposit of materials and for allowing stable power transmission to pass through the dome-shaped dielectric ceiling, through the perforated liner assembly, and into a plasma processing chamber of the plasma reactor;

[0089] FIG. 15 is a vertical sectional view of a dome-shaped dielectric ceiling of the inductively coupled RF plasma reactor of FIG. 12 containing a high density plasma whose density is to be adjusted at a point P;

[0090] FIG. 16 is a vertical sectional view of a dome-shaped dielectric member of FIG. 15 with an assembly of the present invention secured to a certain situs on the inside surface of the dome-shaped dielectric member such that the density of the high density plasma may be adjusted at and/or in close proximity to the point P within the high density plasma;

[0091] FIG. 17 is a vertical sectional view of the dome-shaped dielectric ceiling of the inductively coupled RF plasma reactor of FIG. 12, with the inside surface having dependently coupled thereto a plurality of the assemblies of the present invention for allowing a stable power transmission to pass through the dome-shaped dielectric ceiling and into the process chamber, and containing a plasma whose density is to be adjusted at and/or in proximity to a point P within the plasma;

[0092] FIG. 18 is a horizontal view taken in direction of the arrows and along the plane of line 18-18 in FIG. 17;

[0093] FIG. 19 is a vertical sectional view of a dome-shaped dielectric ceiling of FIG. 12 after one of the assemblies including a deposition support member has been removed from the inside surface of the dome-shaped dielectric ceiling and replaced with another assembly having a deposition support member with a planar surface area that is larger or greater than a planar surface area of the deposition support member from the assembly which was removed, in order to lower the density of the plasma at and/or in proximity to the point P in the plasma;

[0094] FIG. 20 is a horizontal view taken in direction of the arrows and along the plane of line 20-20 in FIG. 19;

[0095] FIG. 21 is the vertical sectional view of the dome-shaped dielectric ceiling from FIG. 12 after one of the assemblies including a deposition support member has been removed from the inside surface of the dome-shaped dielectric ceiling and replaced with another assembly having a deposition support member with a planar surface area smaller or less than a planar surface area of the deposition support member from the assembly which was removed, in order to increase the density of the plasma at and/or in proximity to the point P in the plasma;

[0096] FIG. 22 is a horizontal taken in direction of the arrows and along the plane of line 22-22 in FIG. 21;

[0097] FIG. 23 is a vertical sectional view of the dome-shaped dielectric ceiling of the inductively coupled RF plasma reactor of FIG. 12, with an assembly secured to a certain situs on the outside surface of the dielectric ceiling for engaging and interfering with processing power such that the density of the plasma at and/or in proximity to a point P within the plasma has been adjusted;

[0098] FIG. 24 is vertical sectional view of the dome-shaped dielectric ceiling of the inductively coupled RF plasma reactor of FIG. 12 after an assembly has been positioned away from and not supported by a certain situs on the outside surface of the dielectric member in order to adjust the density of the plasma at and/or in proximity to a point P in the plasma;

[0099] FIG. 25 is a partial perspective view of a dome-shaped dielectric ceiling without any of the assemblies of the present invention attached thereto;

[0100] FIG. 26A is a perspective view of the dome-shaped dielectric ceiling of FIG. 25 after a plurality of the assemblies having been connected to an inside surface of the dielectric ceiling in order to allow stable power transmission to pass through the dielectric ceiling and into a processing chamber and for receiving and supporting a deposit of materials during processing of a semi-conductor wafer in a process chamber supporting the dielectric ceiling;

[0101] FIG. 26B is another perspective view of the dome-shaped dielectric ceiling of FIG. 26A;

[0102] FIG. 26C is also another perspective view of the dome-shaped dielectric ceiling of FIG. 26A;

[0103] FIG. 27 is a plot of the results for the Standard Dome from Table I in Example I illustrating SiO<sub>2</sub> etch rate (Tox ER, Å/min.) vs. RF-on time (mins.);

[0104] FIG. 28 is a plot of the results for the Modified Dome from Table II in Example II illustrating PT etch rate (Å/min.) vs. RF-on time (mins.);

[0105] FIG. 29 is a vertical sectional view of a dome-shaped dielectric ceiling from FIG. 12 containing a heating element electrically engaged to a heat source and a proportional integral differential (PID) controller electrically coupled to the heat source;

[0106] FIG. 30 is a side elevational view of a semiconductor wafer having a semiconductor substrate, a barrier layer disposed on the semiconductor substrate, a platinum layer disposed on the barrier layer, and a plurality of mask layers supported by the platinum layer;

[0107] FIG. 31 is a side elevational view of the semiconductor wafer of FIG. 30 after the platinum layer has been etched to produce an etched platinum layer;

[0108] FIG. 32 is a side elevational view of the semiconductor wafer of FIG. 30 after the platinum layer has been etched to produce an etched platinum layer with residual mask layers on top thereof;

[0109] FIG. 33 is a side elevational view of the semiconductor wafer of FIG. 32 with the residual mask layers removed from the surface of the etched platinum layer; and

[0110] FIG. 34 is a side elevational view of the semiconductor wafer of FIG. 32 after the residual mask layers have been removed from the surface of the etched platinum layer and with the barrier layer having been etched.

#### DESCRIPTION OF THE PREFERRED EMBODIMENTS OF THE INVENTION

[0111] Referring in detail now to the drawings, and initially particularly to FIGS. 1-7, wherein similar parts of the invention are represented by like reference numerals, there is seen an assembly, generally illustrated as 4, for allowing stable power transmission into a process chamber, generally illustrated as 5, having a controlled environment and containing a plasma of a processing gas (e.g., Ar, N<sub>2</sub>, Cl<sub>2</sub>, etc.). Substrates, such as semiconductor wafers (identified as "13" below), are processed within the process chamber 5, such as by plasma etching for patterning integrated circuit (IC)

metal interconnect devices. Other forms of processing substrates which are included within the spirit and scope of the present invention include chemical vapor deposition and physical vapor deposition. During the plasma process, processing power (e.g., RF power, magnetron power, microwave power, etc.) passes through a dielectric member, generally illustrated as 6 in FIGS. 1-6, which includes a dielectric window of a nonconductive material such as a ceramic dome, etc., and becomes coupled to a plasma of the processing gas. If the plasma process is plasma etching, metal etching of metals (e.g., platinum, copper, aluminum, titanium, ruthenium, iridium, etc.) is conducted while being supported by substrates. Also during the plasma process, a deposit, generally illustrated as 7, of materials occurs on an inside surface 6a of the dielectric member 6, as shown in FIG. 2A. The deposit 7 is located between the plasma and the power source. If the plasma process for the present invention is plasma etching, the deposit 7 results from etching a metal layer on the substrate; and, thus, the deposit 7 could be electrically conductive, and includes, by way of example only, metal, metal oxide(s), metal nitride(s), etc. The metal corresponds to the metal which is being etched within the process chamber 5 and includes, also by way of example only, platinum, copper, aluminum, titanium, ruthenium, iridium, etc. When deposit 7 is electrically conductive and is between the plasma and the power source, a decay in processing power transmission occurs and continues until the electrically conductive deposit 7 reaches a certain thickness (i.e., skin depth), such as from about 0.001 in. to about 0.5 in., whereafter the processing power transmission becomes very low or even nil. The deposit 7, therefore, behaves as a Faraday shield to reduce the efficiency of processing power transmission into the plasma of the processing gas within the process chamber 5. When processing power transmission through the dielectric member 6 and into the process chamber 5 commences to decline, the processing (e.g., the etch rate) of the metal layer supported by the substrate starts to decline. In order to maintain a generally stable processing power transmission through the dielectric member 6 and into the process chamber 5, and thus maintain a general stable processing of metal layers (e.g., the etch rate on metal layers) supported by substrates which are being processed within the process chamber 5, the assembly 4 is coupled to, or secured to; or integrally formed with, the dielectric member 6 in order to receive and support the deposit 7. The assembly 4 functions to prevent the deposit 7 on the inside surface 6a of the dielectric member 6 from becoming generally continuous (such as shown in FIG. 2A) during processing of a substrate in the process chamber 5 containing a plasma of the processing gas.

[0112] The assembly 4 of the present invention includes any such assembly or apparatus or member which is capable of functioning for the purpose of assembly 4. In one embodiment of the invention, the assembly 4 includes a plurality of deposition support members 8 supported in an overlapping and spaced relationship with respect to each other by stanchion or brace members 9, as shown in FIGS. 1 and 2. A respective brace member 9 secures to a respective deposition support member 8 and to the inside surface 6a of the dielectric member 6 to posture the respective deposition support member 8 in a spaced relationship with respect to the dielectric member 6. The respective brace members 9 may be secured to the inside surface 6a of the dielectric member 6 and to the respective deposition support members

8 by any suitable means, such as with a high temperature adhesive glue sold by Devcon Corporation, Wood Dale, Ill., 60191 under the trademark Devcon®. As best shown in FIG. 1, the brace members 9 may typically vary in length such that contiguous deposition support members 8-8 overlap and are spaced from each other. As also best shown in FIG. 1, the assembly 4 of the present invention may include a pair of interconnected brace-deposition support member assemblies such as brace member 9a/deposition support member 8a assembly interconnecting to and supporting brace member 9b/deposition support member 8b assembly off of the inside surface 9a of the dielectric member 9. In such an arrangement, brace member 9a connects to the inside surface 6a of the dielectric member 6 and to deposition support member 8a, and brace member 9b mounts to deposition support member 8a and attachedly supports deposition support member 8b. Thus, brace member 9b separates deposition support member 8a from deposition support member 8b. With deposition support members 8a and 8b being in such a spaced position, deposition support member 8c may conveniently extend into the space between deposition support members 8a and 8b as shown in FIG. 1. In another embodiment of the invention, and as best shown in FIG. 3, the assembly 4 consist of deposition support members 8 directly secured or coupled to (or integrally formed with) the inside surface 6a of the dielectric member 6. In this embodiment of the invention, a portion of the structure of the deposition support members 8 functions as a brace member 9.

[0113] In another embodiment of the present invention and as best shown in FIG. 14B, the assembly 4 of the present invention is connected to a liner assembly, generally illustrated as 11, which is supported by a conductive side wall (identified as "108" below) of a reactor chamber (identified as "102" below). The brace members 9 connect to the liner assembly 11 in a similar fashion (e.g., with the high temperature adhesive glue) as the respective brace members 9 connect to the inside surface 6a of the dielectric member 6 and as the respective deposition support members 8 connect to the respective brace members 9. The liner assembly 11 is preferably a perforated network assembly, such as a screen or the like, that is capable of allowing processing power (e.g., energy waves from RF power or magnetron power or microwave power, etc.) to pass through it after passing through the dielectric member 6 (e.g., a dielectric ceiling identified as "110" below). The liner assembly 11 may be a lattice network assembly comprising a plurality of members disposed in a criss-cross fashion. The liner assembly 11 may possess any suitable geometric shape, such as dome-shaped (see FIG. 14B), arcuate shape, rectangular shape, generally planar-like shape, etc. The liner assembly 11 in FIG. 14B is a generally inverted colander-like structure with a plurality of the assemblies 4 connected thereto. The liner assembly 11 may be manufactured from any suitable material (e.g., a dielectric material, etc.) that is capable of allowing processing power to pass therethrough while withstanding the controlled environment to which it is subjected.

[0114] The liner assembly 11 and assembly 4 including the brace members 9 and the deposition support members 8 may be manufactured from any suitable material, such as metal, plastic, electrically non-conductive materials, etc. Preferably, the liner assembly 11 and brace members 9 comprise any substance or material that has an extremely low dielectric constant or low thermal conductivity, or both. The liner

assembly 11 and brace members 9 are preferably essentially non-conductive and may consist of a wide variety of solid types of non-conductive material such as porcelains, glass, mica, magnesia, alumina, aluminum silicate, various high polymers (e.g., epoxies, polyethylene, polystyrene, PVC, phenolics, etc.) cullulosic materials, cellular rubber, nylon, and silicone resins. These low dielectric constant materials may be used alone or in combination with other insulators. The deposition support members 8 are preferably manufactured from a semiconductive material or an electrically conductive material. Suitable semiconductive materials include germanium, silicon, silicon carbide, and selenium, etc., with resistivities in the range of  $10^{-2}$  to  $10^9$  ohms/cm. Suitable electrically conductive materials include metals (e.g., aluminum, copper, platinum, etc.) and alloys, carbon and graphite, etc.

[0115] The brace members 9 and the deposition support members 8 may have any geometric shape. Suitable geometric shapes for the brace members 9 would include brace members 9 having a horizontal cross section representing a square or rectangular planar surface (see FIGS. 1 and 2); or a horizontal cross section representing a triangular or a circular or a trapezoidal planar surface. Suitable geometric shapes for the deposition support members 8 would include deposition support members 8 having a face 8p whose top plan view represents a square, a trapezoid, an irregular shape (see FIGS. 2, 4 and 6), as well as a triangle or any other shape that is capable of receiving and supporting the deposit 7. The faces 8p of the deposition support members 8 may also have any suitable shape in vertical cross-section or side elevational view, such as arcuate, concave, or convex (see FIG. 3), by way of example only. The thickness T (see FIG. 7) of the respective deposition support members 8 should be thicker than the "skin depth" of the deposit 7, such as by way of example only, a thickness greater than about 0.02 inch for the anticipated deposit (e.g., deposit of aluminum) when the process chamber 5 is operating at  $\geq 100$  KHz RF frequency. The face 8p of the respective deposition support members 8 may have any suitable dimensions (e.g., breadth, length, etc.) and any suitable area which would depend on the area of the inside surface 6a of the dielectric member 6 to be spacedly covered with a plurality of the deposition support members 8, and the number of deposition support members 8 to be employed for being extended over the inside surface 6a of the dielectric member 6. The surface area of the face 8p of the respective deposition support members 8 would typically vary from about 1 sq. cm. to about 100 sq. cms. The distance of the space or gap G between contiguous deposition support members 8 would depend on the geometry of the dielectric member 6, the number of deposition support members 8 employed, as well as the respective areas of the respective faces 8p of individual deposition support members 8. Typically, the distance of the gap G would range from about 0.05 cm to about 1.0 cm.

[0116] The purpose of the deposition support members 8 is to receive and support deposit 7 of material that would deposit on the inside surface 6a of the dielectric member 6 if the deposition support members 8 were not available for receiving and supporting the deposit 7. During the processing of substrates in the process chamber 5 containing a plasma of the processing gas, it is believed that the waves of energy from the power transfer pass through the dielectric member 6 and then curve or bend around the respective deposition support members 8 as best shown by the arrows

E in FIG. 5. Deposit 7 that is intended to be deposited on the inside surface 6a of the dielectric member 6 underneath the respective deposition support members 8 is received and supported by the respective deposition support members 8. Any inside surface 6a which is not spacedly covered by a deposition support member 8 receives deposit 7 as best shown in FIGS. 5 and 6. Thus, the deposition support members 8 of the present invention function as a plurality of discreet shields that protect the inside surface 6a of the dielectric member 6 from receiving electrically conductive by-products (i.e., the deposit 7 of materials), while allowing waves of energy from the processing power to be diverted and bent around (see arrows E in FIG. 5) the respective discreet deposition support members 8. This procedure allows and maintains a stable power transmission through the dielectric member 6 and retards a decline in the etch rate taking place on a substrate being processed within the process chamber 5 containing a plasma of a processing gas.

[0117] The assembly 4 of the present invention may be used with any prior art plasma processing apparatus. In a preferred embodiment of the present invention, the assembly 4 is employed in prior art reactors schematically shown in FIGS. 8 through 11 and having the common features of a power transfer across dielectric windows and a separate bias supply at the wafer electrode. The prior art reactors in the schematic diagrams of FIGS. 8 through 11 differ significantly however in the means by which power is coupled to the plasma. For the electron cyclotron resonance (ECR) source depicted in FIG. 8, there is seen an ECR source reactor, generally illustrated as 10, having a cylindrical source chamber 12 with a dielectric window 14. The cylindrical source chamber 12 communicates with a process chamber 16 and at least one multidipole permanent magnet 18 surrounds the circumference of the process chamber 16 to increase radial plasma uniformity. The cylindrical source chamber 12 is surrounded by at least one electromagnet coil 22 to generate an axially varying dc magnetic field. A chuck or pedestal 26 is disposed in the process chamber 16 for supporting substrates including semiconductor wafers 13. The pedestal 26 is electrically connected to a bias RF source 30. Microwave power is injected axially in direction of the arrow A in FIG. 8, and through the dielectric window 14 into a processing gas (e.g., Ar, N<sub>2</sub>, Cl<sub>2</sub>, etc.) or source plasma within the cylindrical source chamber 12, where the microwave power excites a right-hand circularly polarized wave that propagates to a resonance zone where the wave is absorbed. The resulting plasma subsequently flows out of the cylindrical source chamber 12 into the process chamber 16 where the semiconductor wafer 13 is supported by the pedestal 26. ECR sources have been increasingly used for thin film deposition and etching due to their ability to deliver high-current densities (tens of mA/cm<sup>2</sup>) at low ion energy (a few tens of eV). Because by-products resulting from processing substrates in the ECR source reactor 10 cause coating of the dielectric window 14, which could result in significant absorption of incident microwave power and a decrease in source efficiency, a plurality of the assemblies 4 of the present invention is connected to the dielectric window 14 in any suitable format, such as any of the formats as shown in FIGS. 1 or 3 or 5, in order for the deposition support members 8 to be in a position to receive and support by-product deposits and prevent the coating (e.g., the deposit 7) of the dielectric window 14.

[0118] Referring now to FIG. 9 for another prior art reactor which may employ the assembly 4 of the present invention and which transfers power across a dielectric window and has a separate bias supply at the wafer electrode, there is seen a helicon source reactor, generally illustrated as 34, having a dielectric cylinder, generally illustrated as 38. The dielectric cylinder 38 is surrounded by at least one electromagnet coil 42 and an RF antenna, generally illustrated as 46, is disposed in proximity to the dielectric cylinder 38. The dielectric cylinder 38 is manufactured from non-conductive or dielectric material and functions as a plasma chamber where plasma is generated. The plurality of the assemblies 4 of the present invention may be connected to the inside cylindrical surface of the dielectric cylinder 38 in any suitable format, such as any of the formats illustrated in FIGS. 1, 3 or 5. The dielectric cylinder 38 communicates with a process chamber, generally illustrated as 50. At least one multidipole permanent magnet 18 surrounds the circumferential area of the process chamber 50 to increase radial plasma uniformity. Pedestal 26 is situated in the process chamber 50 for supporting substrates including semiconductor wafers 13, and is electrically connected to the bias RF source 30. A weak (e.g., 50-200 G) dc axial magnetic field emanating from the electromagnet coil 42 and passing through the dielectric cylinder 38, along with the rf-driven antenna 46 in proximity to the dielectric cylinder 38, allows execution of a helicon wave within a processing gas (e.g., Ar, N<sub>2</sub>, Cl<sub>2</sub>, etc.) contained in the dielectric cylinder 38. Resonant wave-particle (Landau damping) is believed to transfer helicon wave energy into the processing gas to produce the plasma which subsequently flows out of the dielectric cylinder 38 into the process chamber 50 where the semiconductor wafer 13 is supported by the pedestal 26. As was previously indicated, the effect of the multidipole magnet 18, which surrounds the process chamber 50 is to increase radial plasma uniformity. Because by-products resulting from processing substrates in the helicon source reactor 34 cause deposits on the inside surfaces of the dielectric cylinder 38, the assemblies 4 are disposed on the inside cylindrical surface of the dielectric cylinder 38 to position the deposition support members 8 for receiving and supporting by-product deposits (e.g., deposit 7 of materials) to keep the inside cylindrical surface of the dielectric cylinder 38 free of electrical conductive by-products.

[0119] Another prior art reactor employing a dielectric window wherethrough processing power is transferred along with possessing a separate bias supply at the wafer electrode, is a helical resonator reactor, generally illustrated as 54 in FIG. 10. The helical resonator reactor 54 may also employ a plurality of the assemblies 4 of the present invention. The helical resonator reactor 54 includes a dielectric discharge chamber 58 supported by and communicating with a process chamber 62. The dielectric discharge chamber 58 is helically surrounded by a helix 64 which is coupled to an RF power source 68 via conductor 70 and is grounded at 72 to a cylindrical conducting shield 76 which is preferably manufactured from copper. The helix 64 is generally concentrically disposed around the dielectric discharge chamber 58. The process chamber 62 is surrounded by one or more multidipole permanent magnets 18 in order to increase radial plasma uniformity. Pedestal 26 is disposed in the process chamber 62 for supporting substrates (e.g., semiconductor wafers 13) and is electrically coupled to the bias RF source

30. The helical resonator reactor 54 has a high characteristic impedance and operates at radio frequencies ranging from about 3 MHz to about 30 MHz and exhibits high Q, typically ranging from about 600 to about 1500. The helix 64 and the cylindrical conducting shield 76 coaxially surrounding the dielectric discharge chamber 58 form a slow wave structure; i.e., supporting an electromagnetic wave propagation along the z-axis with a phase velocity much less than the velocity of light. The composite slow wave structure becomes resonant by excitation of a resonant axial mode occurring when an integral number of quarter waves of the RF field fit between opposed ends of the dielectric discharge chamber 58. When this condition occurs, the intense electromagnetic fields within the helix 64 efficiently couples the rf power to the plasma and sustains the plasma with negligible matching loss at low gas pressure. In order to have efficiently coupling of the rf power through the dielectric discharge chamber 58 to the plasma, the inside surface of the dielectric discharge chamber 50 must be free of electrical conductive by-products such as metal oxides and the like. A plurality of the assemblies 4 are coupled to the inside surface of the dielectric discharge chamber 58 in any suitable format, such as any of the formats of FIGS. 1, 3 or 5, to posture the deposition support members 8 to receive and support electrical conductive by-products (e.g., the deposit 7 of materials) and to prevent a build-up of such electrical conductive by-products on the inside surface(s) of the dielectric discharge chamber 58.

[0120] Referring now to FIG. 11 for a schematic diagram of still another prior art reactor which may employ the assemblies 4 of the present invention and has the features of a power transfer across a dielectric window and a separate bias supply at the wafer electrode, there is seen an inductively coupled plasma reactor, generally illustrated as 80. The inductively coupled plasma reactor 80 comprises a dielectric discharge chamber 84 that is circumferentially surrounded by a multiturn, non-resonant cylindrical rf coil 86 (i.e., helical rf inductive coil 86) that is coupled to an RF power source 88. A plurality of the assemblies 4 is coupled to an inside cylindrical surface of the dielectric discharge chamber 84 to receive and support electrically conductive by-products (e.g., the deposit 7 of materials) off of the inside cylindrical surface of the dielectric discharge chamber 84. The dielectric discharge chamber 84 communicates with a process chamber 90 which is surrounded by one or more multidipole permanent magnets 18 to increase radial plasma uniformity. As was seen for the prior art reactors of FIGS. 8-10, pedestal 26 is disposed in the process chamber 90 for supporting substrates including semiconductor wafers 13. Pedestal 26 is electrically coupled to bias RF source 30.

[0121] Inductively coupled plasma reactors, such as reactor 80 in FIG. 11, are currently used to perform various processes on semiconductor wafers including metal etching, dielectric etching, chemical vapor deposition, and physical vapor deposition, as some examples. In an etch process, one advantage of an inductively coupled plasma is that a high density plasma ion density is provided to permit a large etch rate with a minimal plasma D.C. bias, thereby permitting more control of the plasma D.C. bias to reduce device damage. For this purpose, the source power applied to the inductive coil and the D.C. bias power applied to the wafer pedestal are separately controlled RF supplies. Separating the bias and source power supplies facilitates independent control of ion density and ion energy, in accordance with

well-known techniques. Plasma in an inductive source is created by application of rf power to a non-resonant inductive coil, such as helical coil **86** in **FIG. 11**, or a planar coil (not shown) for a close-coupled or planar source geometry as shown and described on pages 52-53 of an article entitled "Design of High-Density Plasma Sources" by Lieberman et al from Volume 18 of "Physics of Thin Films", copyright 1994 by Academic Press Inc. of San Diego, Calif. The application of rf power to a non-resonant inductive coil results in the breakdown of the process gas within a dielectric discharge chamber, such as the dielectric discharge chamber **84** in **FIG. 11**, by the induced rf electric field which passes through the dielectric discharge chamber. Therefore, the coil inductor provides RF power which ignites and sustains the plasma of the processing gas.

[0122] A preferred inductively coupled plasma reactor for employing a plurality of the assemblies **4** of the present invention is that which inductively couples a plasma in a decoupled plasma source etch chamber sold under the trademark DPS™ owned by Applied Materials, Inc., 3050 Bowers Avenue, Santa Clara, Calif. 95054-3299. The DPS™ brand etch chambers decouples or separates the ion flux to the semiconductor wafer **13** from the ion acceleration energy and may be any of the DPS™ brand etch chambers of the inductively coupled plasma reactors disclosed in co-pending U.S. patent application Ser. No. 08/389,889 filed Feb. 15, 1995, entitled "RF PLASMA REACTOR WITH HYBRID CONDUCTOR AND MULTI-RADIUS DOME CEILING" and assigned to the present assignee and fully incorporated herein by reference thereto as if repeated verbatim immediately hereinafter. Referring now to **FIGS. 12 and 13** for two (2) embodiments of an inductively coupled plasma reactor from co-pending application Ser. No. 08/389,889, there is seen an inductively coupled RF plasma reactor, generally illustrated as **100**, having a reactor chamber, generally illustrated as **102**, wherein a high density plasma **104** of neutral (n) particles, positive (+) particles, and negative (-) particles are found. The reactor chamber **102** has a grounded conductive cylindrical sidewall **108** and a dielectric ceiling or window **110**. A plurality of the assemblies **4** of the present invention may be secured to an inside surface of the dielectric ceiling **110** as best shown in **FIG. 14**. The inductively coupled RF plasma reactor **100** further comprises a wafer pedestal **114** for supporting the (semiconductor) wafer **13** in the center of the chamber **102**, a cylindrical inductor coil **120** surrounding an upper portion of the chamber **102** beginning near the plane of the top of the wafer **13** or wafer pedestal **114** and extending upwardly therefrom toward the top of the chamber **102**, an etching gas source **124** and gas inlet **128** for furnishing an etching gas into the interior of the chamber **102**, and a pump **132** for controlling the pressure in the chamber **102**. The coil inductor **120** is energized by a plasma source power supply or RF generator **136** through a conventional active RF match network **140**, the top winding of the coil inductor **120** being "hot" and the bottom winding being grounded. The wafer pedestal **114** includes an interior conductive portion **144** connected to the bias RF power supply or generator **148** and an exterior grounded conductor **152** (insulated from the interior conductive portion **144**). Thus, the plasma source power applied to the coil inductor **120** by the RF generator **136** and the DC bias RF power applied to the wafer pedestal **114** by generator **148** are separately controlled RF supplies. Separating the bias and source power supplies facilitates

independent control of ion density and ion energy, in accordance with well-known techniques. To produce high density plasma **104** as an inductively coupled plasma, the coil inductor **120** is adjacent to the chamber **102** and is connected to the RF source power supply or the RF generator **136**. The coil inductor **120** provides the RF power through the dielectric ceiling or window **110** which ignites and sustains the high ion density of the high density plasma **104**. The geometry of the coil inductor **120** can in large part determine spatial distribution of the plasma ion density of the high density plasma **104** within the reactor chamber **102**. The assemblies **4** allow stable power transmission to pass through the dielectric ceiling **110** and into the chamber **102** since the assemblies **4** would receive the deposit **7** of material and keep the inside surface of the dielectric ceiling **110** free of the electrically conductive deposit **7**. The assemblies **4** would also prevent the deposit **7** of materials from becoming generally continuous during processing (e.g., metal etching) of the semiconductor wafer **13** in the high density plasma **104**.

[0123] Uniformity of the plasma density spatial distribution of the high density plasma **104** across the wafer **13** is improved (relative to conical or hemispherical ceilings) by shaping the ceiling **110** in a multi-radius dome and individually determining or adjusting each one of the multiple radii of the ceiling **110**. The multiple-radius dome shape in the particular embodiment of **FIG. 12** somewhat flattens the curvature of the ceiling **110** around the center portion of the ceiling **110**, the peripheral portion of the ceiling **110** having a steeper curvature.

[0124] As illustrated in **FIG. 13** the coil inductor **120** may be coupled to the RF power source **136, 140** in a mirror coil configuration that is known to those skilled in the art. In the mirror coil configuration of **FIG. 13**, the RF source **136, 140** is connected to the center winding of the coil inductor **120** while the top and bottom ends of the coil inductor **120** are both grounded. The mirror coil configuration has the advantage of reducing the maximum potential on the coil inductor **120**.

[0125] In another embodiment of the present invention there is provided a method for adjusting the density of plasma contained in a chamber (e.g., reactor chamber **102** in **FIGS. 12-13**) wherein substrates (e.g., semiconductor wafers **13**) are to be processed. In one preferred embodiment of this method and referencing **FIGS. 15 and 16**, after it has been determined that the density of the high density plasma **104** should be adjusted at a location within the reactor chamber **102** in proximity to a spot S (see **FIG. 16**) on the inside surface of the dielectric ceiling **110**, such as at a point P within the high density plasma **104** (see **FIGS. 15 and 16**), processing power to the coil conductor **120** from the RF generator **136** (i.e., the plasma source power supply) through the conventional active RF match network **140** is interrupted (i.e., it is shut-off). The dielectric ceiling **110** is removed from engagement with the conductive sidewall **108**. Subsequently and as best shown in **FIG. 16**, an assembly **4**, including brace **9** deposition support member **8**, is secured to the spot S on the inside surface of the dielectric ceiling **110**. The dielectric ceiling **110** is reconnected to the conductive sidewall **108**, and when processing power from the coil conductor **120** is reintroduced through the dielectric ceiling **110** and into the reactor chamber **102**, the density of the high density plasma **104** at and/or in proximity to point

P is adjusted. Typically and depending on the composition (e.g., electrically conductive vs. semiconductive, etc.) of the deposition support member **8** and the area of the planar face **8p** of the deposition support member **8**, the density of the high density plasma **104** at and/or in proximity to point P would be decreased. While this embodiment of the present invention has been described employing an inductively coupled RF plasma reactor, i.e., inductively coupled RF plasma reactor **100** of FIGS. 12 and 13, it is to be understood that the spirit and scope of the present invention includes the use of the assembly **4** on dielectric members of other prior art plasma processing apparatuses (e.g., ECR source reactors, helicon source reactors, helical resonator reactors, etc.) employing other types of processing power (e.g., magnetron power, microwave power, etc.). It is also to be understood that while this embodiment of the present invention has been described by employing a single assembly **4** (see FIG. 16) for adjusting the density of plasma, the spirit and scope of the present invention would include the employment of a plurality of assemblies **4** for adjusting the density of plasma. The plurality of the assemblies **4** would include respective deposition support members **8** disposed in an overlapping and spaced relationship with respect to each other. The assembly or assemblies **4** would receive and support a deposition of materials (e.g., the deposit **7** of materials) during processing (e.g., metal etching) of at least one semiconductor wafer **13** in a reactor chamber, such as reactor chamber **102** in FIGS. 12 and 13.

[0126] In another embodiment of a method for adjusting the density of plasma and referring in detail now to FIGS. 17-22, there is seen in FIG. 17 a vertical sectional view of the dome-shaped dielectric ceiling **110** of the inductively coupled RF plasma reactor **100** of FIG. 12, with the inside surface of the dielectric ceiling **110** having secured thereto and depending therefrom a plurality of the assemblies **4**. The reactor chamber **102** including the dielectric ceiling **110** contains the high density plasma **104** whose density is to be adjusted at and/or in proximity to a point P within the plasma **104**. One of the assemblies **4** which is closest to the point P in the plasma **104** has been conveniently designated as assembly **4R** (see FIG. 17) and includes a brace **9** attached at a spot W on the inside surface of the dielectric ceiling **110**. This particular brace **9** supports a deposition support member **8R** having a face **8p** in the general form of a square for illustration purposes only. After it has been determined that the density of the high density plasma **104** should be adjusted at a location within the reactor **102** in proximity to spot W, which is in proximity to point P within the high density plasma **104**, processing power to the coil conductor **120** from the RF generator **136** through the conventional active RF match network **140** is interrupted by being shut down. The dielectric ceiling **110** is removed from engagement with the conductive sidewall **108** and assembly **4R** is removed from spot W; or alternatively, deposition support member **8R** is removed from the particular brace **9** which supports the same. Depending on whether the density of the plasma **104** at point P is to be reduced or increased, the removed assembly **4R** is to be replaced by assembly **4R1** (see FIGS. 19 and 20) or by assembly **4R2** (see FIGS. 21 and 22); or the removed deposition support member **8R** is to be replaced by deposition support member **8R1** or by deposition support member **8R2**.

[0127] The deposition support member **8R1** of assembly **4R1** has a face **8p** with a larger or greater than surface area

than the surface area of face **8p** of deposition support member **8R** of assembly **4R**. Deposition support member **8R2** has a face **8p** with a surface area that is smaller or less than the surface area of the face **8p** of the deposition support member **8R** of assembly **4R**. If the density of the plasma **104** at point P is to be decreased, then deposition support member **8R1** is to replace deposition support member **8R** or the assembly **4R1** with deposition support member **8R1** is to replace the assembly **4R** with the deposition support member **8R**. Similarly, if the density at point P in plasma **104** is to be increased, then deposition support member **8R2** is to replace deposition support member **8R**, or assembly **4R2** with deposition support member **8R2** is to replace the assembly **4R** having deposition support member **8R**. Stated alternatively, replacing assembly **4R** with an assembly that has a deposition support member having a face **8p** with a greater surface area reduces the density of the plasma **104** at point P when processing power from the coil conductor **120** is reintroduced through the dielectric ceiling **110** and into the reactor chamber **102**. Similarly, replacing the assembly **4R** with an assembly that has a deposition support member having a face **8p** with a smaller surface area, increases the density plasma **104** at point P when processing power from the coil conductor **120** is reintroduced through the dielectric ceiling **110** and into the reactor chamber **102**. It is to be understood that whenever "a greater surface area" or "a surface area that is larger than", or the like, is stated or used in the specification and/or in the claims with respect to a particular face **8p** of a particular deposition support member **8R1**, such terms broadly mean that the particular deposition support member **8R1** has a different geometric structure (e.g., a longer width/breadth or longer length, etc.) than the geometric structure of the deposition support member **8R** which was replaced by the particular deposition support member **8R1** such that the waves of energy from the power transfer have to travel a longer or greater distance to curve or bend around the particular deposition support member **8R1** (see arrows E in FIG. 5) than for replaced deposition support member **8R**. Similarly, whenever "a smaller surface area" or "a surface area that is smaller than", or the like, is stated or used in the specification and/or in the claims with respect to a particular face **8p** or a particular deposition support member **8R2**, such terms broadly mean that the particular depositions support member **8R2** has a different geometric structure (e.g., a shorter width/breadth or shorter length, etc.) than the geometric structure of the deposition support member **8R** which was replaced by the particular deposition support member **8R2** such that the waves of energy from the power transfer travel a shorter or smaller distance to curve or bend around the particular deposition support member **8R2** than for replaced deposition support member **8R**.

[0128] After the processing power from the coil conductor **120** has been reintroduced, the process power may be interrupted or shut down again. The dielectric ceiling **110** may be removed and the deposit of material (i.e., deposit **7**) from the deposition support members **8** may be removed or cleaned therefrom. While this alternate embodiment of the present invention has been described employing an inductively coupled RF plasma reactor, i.e., inductively coupled RF plasma reactor **100** of FIGS. 12 and 13, it is to be understood that the spirit and scope of the present invention includes the use of the assemblies **4** and assemblies **4R** or **4R1** or **4R2** on dielectric members of other prior art plasma

processing reactors (e.g., ECR source reactors, helicon source reactors, helical resonator reactors, etc.) employing other types of processing power (e.g., magnetron power, microwave power, etc.). It is also to be understood while this embodiment of the present invention has been described as removing a single assembly 4R and replacing the same with assembly 4R1 or 4R2 for adjusting the density of the plasma, the spirit and scope of the present invention would include the employment of a plurality of removed assemblies 4R and a plurality of replacement assemblies for adjusting the density of plasma.

[0129] Still another embodiment of the present invention and referring in detail now to FIGS. 23-24, there is seen a vertical sectional view of the dielectric ceiling 110 of the inductively coupled RF plasma reactor 100 of FIG. 12, having assembly 4 secured to a certain situs on the outside surface of the dielectric ceiling 110 for engaging and interfering with processing power emanating from the coil conductor 120 such that the density of the plasma density 104 at and/or in proximity to a point P within the plasma 104 has been adjusted. Alternatively with respect to this embodiment of the invention, there is seen in FIG. 24 a vertical sectional view of the dielectric ceiling 110 of the inductively coupled RF plasma reactor 100 of FIG. 12, after assembly 4 has been positioned away from and not supported by the certain situs of the outside surface of the dielectric ceiling 110 in order to adjust the density of the plasma 104 at and/or in proximity to a point P in the plasma.

[0130] As was previously indicated, while the use of at least one of the assemblies 4 for various embodiments of the present invention has been described employing an inductively coupled RF plasma reactor (e.g., inductively coupled RF plasma reactor 100 of FIGS. 12 and 13), it is to be understood that the spirit and scope of the present invention includes the use of at least one of the assemblies 4 with other prior art plasma processing apparatuses (e.g., ECR source reactors, helicon source reactors, helical resonator reactors, etc.) employing other types of processing power (e.g., magnetron power, microwave power, etc.).

[0131] Referring in detail now to FIG. 29, there is seen another embodiment of the present invention for allowing a stable power transmissions into a plasma processor chamber 5, such as reactor chamber 102 in FIGS. 12 and 13. For this preferred embodiment of the present invention, the inside surface 6a of the dielectric member 6 is heated to a sufficient enough temperature such that the deposit 7 does not form on the inside surface 6a. The deposit 7, especially when the metal being processed is platinum, has a conductivity (i.e., electrical conductivity) which increases as the thickness (i.e., skin depth) of the deposit 7 decreases. Thus, the thinner the skin depth of a deposit 7, the more conductive it becomes; and the more conductive the deposit 7 becomes, the more resistive the deposit 7 becomes in not allowing processing power to pass therethrough. Whenever "resistivity" is mentioned in the specification, it pertains to the ability for preventing and/or reducing the passage of processing power through the dielectric member 6. Therefore, the higher the resistivity for blocking the passage of processing power, the greater the conductivity. Thus, the higher the conductivity of the deposit 7, the less efficient the transmission of processing power through the dielectric member 6 becomes. The ability to transmit processing power through the dielectric member 6 decreases as the conductivity of the

deposit 7 increases. Therefore, in a preferred embodiment of the present invention, the inside surface 6a of the dielectric member 6 is heated to a sufficient enough temperature such that essentially no deposit 7 occurs on the inside surface 6a. The temperature to which the inside surface 6a is to be heated would depend on the type of metal layer which is being processed on the substrate. Preferably, and especially when the metal layer being processed on the substrate is platinum, the inside surface 6a of the dielectric member 6 is heated to a temperature greater than about 150° C., such as a temperature ranging from about 150° C. to about 500° C. More preferably, the temperature is greater than about 200° C., such as a temperature ranging from about 200° C. to about 400° C. Most preferably, the temperature is greater than about 225° C., such as a temperature ranging from about 225° C. to about 300° C.

[0132] The inside surface 6a of the dielectric member 6 may be heated in any suitable 10 manner, such as the manner(s) disclosed in commonly owned U.S. Pat. No. 5,477,975 to Rice et al., fully incorporated herein by reference thereto as if repeated verbatim immediately hereinafter. More specifically and as best shown in FIG. 29 for the inductively coupled plasma reactor of FIGS. 12 and 13 by way of example only, there is seen the dielectric ceiling 110 as having an inside or interior surface 110a. In order to maintain the temperature of the interior surface 110a above about 150° C., a heating element 200 is disposed in and rests in the interior of the dielectric ceiling 110. The heating element 200 is coupled to a heat or electrical source 210. The heating element 200 is preferably a cable heating element 200 manufactured by Watlow, Inc., 12001 Lackland Road, St. Louis, Mo., and is operated at any suitable watts and volts such that the interior surface 110a is at a temperature which prevents the deposit 7 from forming thereon. Obviously, the watts and volts would depend on the type of dielectric materials which are constituents of the dielectric ceiling 110. Preferably and by way of example only, the heating element is operated by applying from about 800 watts to about 1400 watts at from about 180 volts to about 260 volts. It is to be understood that the dielectric ceiling 110 may be heated by a lamp, by hot air from a hot-air blower, or by any other suitable means.

[0133] In order to provide accurate temperature control of the dielectric ceiling 110, a temperature sensor (not shown) may be mounted on the outer surface of the dielectric ceiling 110. The temperature sensor is coupled to a temperature controller 220 for maintaining the temperature of the outer surface of the dielectric ceiling 110 at a desired temperature. Typically, depending on the dielectric constituents of the dielectric ceiling 110, there is a temperature gradient of from about 2° C. to about 30° C. between the outer surface of the dielectric ceiling 110 and the interior surface 110a. In a preferred embodiment of the present invention, the temperature controller 220 is a conventional PID (proportional integral differential) controller which is readily programmed by the skilled worker such that the interior surface 110a of the dielectric ceiling 110 has the desired temperature. The PID controller 220 may be programmed such that the cable heating element 200 is energized at any suitable time, such as continuously when the plasma is ignited and not ignited, or selectively when the plasma is either ignited or not ignited. Thus, when processing power is passing through the dielectric ceiling 110, the dielectric ceiling 110 is being and/or has been heated such that processing power is being

passed through a heating element-heated dielectric ceiling **110**. A necessary condition for maintaining the interior surface **110a** of the dielectric ceiling **110** at a desired temperature is to take into consideration the heat flow from the plasma **104** in the reactor chamber **102** through the dielectric ceiling **110**. The plasma **104** in the reactor chamber **102** generates a certain watts of heat in the dielectric ceiling **110**. The temperature control loop comprising the PID controller **220** is capable of regulating the temperature of the dielectric ceiling **110** at all times, even when a plasma (e.g., plasma **104**) is ignited in the reactor chamber **102**.

[0134] The embodiment of the invention illustrated in FIG. 29 may be used for processing any metal (e.g., platinum, copper, aluminum, titanium, ruthenium, iridium, etc.) on a substrate and with any prior art plasma processing apparatus. In a preferred embodiment of the present invention and by way of example, the embodiment of the invention illustrated in FIG. 29 is employed for metal etching of metals, preferably for etching platinum. By further way of example only and referring now to FIGS. 30-34, there is seen in FIG. 30 a wafer, generally illustrated as **300** and including a semiconductor substrate **312**, a barrier layer **314** (e.g., titanium and/or a titanium alloy) disposed over the semiconductor substrate **312**, and a platinum layer, generally illustrated as **316**, disposed over the barrier layer **314**. The platinum layer **316** supports mask layers **318a**, **318b**, **318c** and **318d**. Before and/or during etching of the platinum layer **316**, a dielectric member (e.g., the dielectric member **6**) of any suitable plasma processing apparatus is heated such that an interior surface (e.g., inside surface **6a**) of the dielectric member possesses a temperature greater than about 150° C. (e.g., 150° C-500° C.), more preferably greater than about 200° C. (e.g., 200° C-400° C.), most preferably greater than about 225° C. (e.g., 225° C-300° C.). This prevents the deposit **7** (e.g., platinum by-products) from forming and/or depositing on the interior surface of the dielectric member while processing power is passing through the dielectric member.

[0135] The platinum layer **316** may be etched in any suitable plasma processing apparatus, such as in the reactive ion etch (RIE) plasma processing apparatus sold under the trademark AME8100 Etch™, or under the trademark Precision Etch 5000™, or under the trademark Precision Etch 8300™, all trademarks owned by Applied Materials Inc., 3050 Bowers Avenue, Santa Clara, Calif. 95054-3299. Another suitable plasma processing apparatus for etching the platinum layer **316** is that plasma processing apparatus sold under the trademark Metal Etch DPS Centura™ also owned by Applied Materials, Inc. It is also to be understood that other plasma etchers may be employed, such as ECR, ICP, Helicon Resonance, etc.

[0136] A suitable plasma processing apparatus for etching the platinum layer **316** employs a plasma of an etchant gas, which is capable of producing good platinum profiles (e.g., platinum profiles equal to or greater than about 85 degrees, preferably equal to or greater than about 87 degrees, more preferably equal to or greater than about 88.5 degrees). The etchant gas broadly comprises a halogen containing gas, such as a halogen gas (e.g., fluorine, chlorine, bromine, iodine, and astatine) and a noble gas such as helium, neon, argon, krypton, xenon, and radon. Preferably, the etchant gas comprises or consists of or consists essentially of a halogen (preferably chlorine) and a noble gas selected from the

group consisting of helium, neon, and argon. The noble gas is preferably argon. The etchant gas more specifically comprises preferably from about 20% by volume to about 95% by volume of the halogen gas (i.e., chlorine) and from about 5% by volume to about 80% by volume of the noble gas (i.e., argon); more preferably from about 40% by volume to about 80% by volume of the halogen gas (i.e., chlorine) and from about 20% by volume to about 60% by volume of the noble gas (i.e., argon); most preferably from about 55% by volume to about 65% by volume of the halogen gas (i.e., chlorine) and from about 35% by volume to about 45% by volume of the noble gas (i.e., argon).

[0137] In another preferred embodiment of the invention, the etchant gas comprises, preferably consists of or consists essentially of, the halogen (i.e., chlorine), the noble gas (i.e., argon), and a gas selected from the group consisting of HBr, BCl<sub>3</sub> and mixtures thereof. The etchant gas more specifically comprises, or consists of or consists essentially of, from about 10% by volume to about 90% by volume of the halogen gas (i.e., chlorine) and from about 5% by volume to about 80% by volume of the noble gas (i.e., argon) and from about 4% by volume to about 25% by volume of HBr and/or BCl<sub>3</sub>; preferably from about 40% by volume to about 70% by volume of the halogen gas (i.e., chlorine) and from about 25% by volume to about 55% by volume of the noble gas (i.e., argon) and from about 5% by volume to about 20% by volume of HBr and/or BCl<sub>3</sub>; and more preferably from about 50% by volume to about 60% by volume of the halogen gas (i.e., chlorine) and from about 35% by volume to about 45% by volume of the noble gas (i.e., argon) and from about 5% by volume to about 15% by volume of HBr and/or BCl<sub>3</sub>. The etchant gas flow rate ranges from about 50 sccm to about 500 sccm. HBr and/or BCl<sub>3</sub> are for removal of platinum residue during etching of the platinum layer **316**. Plasmas containing argon are known to have a high energetic ion concentration and are often used for physical sputtering. The sputtering effect due to the ions is a function of the accelerating potential which exist between the plasma and the sample.

[0138] As previously indicated, a more preferred etchant gas for etching the platinum layer **316** is a mixture of chlorine and argon, or a mixture of chlorine, argon and HBr and/or BCl<sub>3</sub>. If the etchant gas is a mixture of chlorine and argon (i.e., from about 20% by volume to about 95% by volume chlorine and from about 5% by volume to about 80% by volume argon), or a mixture of chlorine, argon and HBr and/or BCl<sub>3</sub> (i.e., from about 10% by volume to about 90% by volume chlorine and from about 5% by volume to about 80% by volume argon and from about 4% by volume to about 25% by volume HBr and/or BCl<sub>3</sub>), and if the dielectric member (e.g., dielectric member **6** such as dielectric ceiling **110**) of a plasma processing apparatus is heated to a temperature greater than about 150° C., preferably to a temperature ranging from about 150° C. to about 500° C., the plasma processing apparatus for etching the platinum layer **316** etches the platinum layer **316** in a high density plasma of the etchant gas at a high platinum etch rate (i.e., an etch rate higher than 1000 Å/min) and produces an etched platinum layer, generally illustrated as **316e** (as best shown in FIG. 31). The etched platinum layer **316e** includes etched platinum layers **316a**, **316b**, **316c** and **316d** having corners **316g** and sidewalls **316s** and an excellent platinum profile; that is, a platinum profile where the angle of the sidewalls **316s** (as also best shown in FIG. 31) with respect to a horizontal plane is equal to or greater than about 80 degrees.

[0139] The high density plasma of the present invention may be defined as a plasma of the etchant gas of the present invention having an ion density greater than about  $10^9/\text{cm}^3$ , preferably greater than about  $10^{11}/\text{cm}^3$ . The source of the high density plasma may be any suitable high density source, such as electron cyclotron resonance (ECR), helicon resonance or inductively coupled plasma (ICP)-type sources. All three are in use on production equipment today. The main difference is that ECR and helicon sources employ an external magnetic field to shape and contain the plasma, while ICP sources do not.

[0140] The high density plasma for the present invention is more preferably produced or provided by inductively coupling a plasma in a decoupled plasma source etch chamber, such as that sold under the trademark DPS™ owned by Applied Materials, Inc. which decouples or separates the ion flux to the wafer 300 and the ion acceleration energy. The design of the etch chamber provides fully independent control of ion density of an enlarged process window. This is accomplished by producing plasma via an inductive source. While a cathode within the etch chamber is still biased with rf electric fields to determine the ion acceleration energy, a second rf source (i.e., an inductive source) determines the ion flux. This second rf source is not capacitive (i.e., it does not use electric fields like the cathode) since a large sheath voltage would be produced, interfering with the cathode bias and effectively coupling the ion energy and ion flux.

[0141] The inductive plasma source couples rf power through a dielectric window rather than an electrode. The power is coupled via rf magnetic fields (not electric fields) from rf current in a coil. These rf magnetic fields penetrate into the plasma and induce rf electric fields (therefore the term “inductive source”) which ionize and sustain the plasma. The induced electric fields do not produce large sheath voltages like a capacitive electrode and therefore the inductive source predominantly influences ion flux. The

wafer bias allows independent control of the ion flux and ion energy reaching the wafer 300 in the etch chamber, such as the DPS™ brand etch chamber or any other suitable inductively coupled plasma reactor.

[0142] The preferred reactor conditions for a suitable inductively coupled RF plasma reactor, such as the inductively coupled RF plasma reactor 100 of FIGS. 12 and 13 having the dielectric ceiling 110 illustrated in FIG. 29, in etching the platinum layer 316 are as follows:

Pressure	0.1 to 300 mTorr
RF Power to Coil Inductor	100 to 5000 watts
RF Power to Wafer Pedestal	50 to 3000 watts
RF Frequency in Coil Inductor	100K to 300 MHz
RF Frequency in Wafer Pedestal	100K to 300 MHz
Temperature of Wafer	20 to 500° C.
Temperature (° C.) of Interior Surface of Dielectric Ceiling	150 to 500° C.
Platinum Etch Rate	200 to 6000 Angstrom/min

[0143] More generally, the process parameters for etching the platinum layer 316 in a suitable inductively coupled plasma reactor, such as the inductively coupled plasma reactor 100 of FIGS. 12 and 13 having the dielectric ceiling 110 illustrated in FIG. 29, fall into ranges as listed on the basis of flow rates of the gases, including the halogen gas(es) (i.e.,  $\text{Cl}_2$ ) and the noble gas(es) (i.e., argon), as listed in Table I below.

TABLE I

Process Gas Flow, sccm	Broad	Preferred	Optimum
$\text{Cl}_2$	30 to 400	50 to 250	60 to 150
Ar	20 to 300	30 to 200	40 to 100
Pressure, mT	0.1 to 300	10 to 100	10 to 40
RF Power of Coil Inductor (Watts)	100 to 5000	650 to 2000	900 to 1500
RF Power of Wafer Pedestal (Watts)	50 to 3000	100 to 1000	150 to 400
Temperature of Wafer (° C.)	about 20 to about 500	100 to 300	100 to 130
Temperature (° C.) of Interior Surface of Dielectric Ceiling	about 20 to about 500	200 to 400	225 to 300
Platinum Etch Rate (Å/min)	200 to 6000	500 to 3000	1000 to 2000
RF Frequency of Coil Inductor	100K to 300 MHz	400K to 20 MHz	2 to 13.5 MHz
RF Frequency of Wafer Pedestal	100K to 300 MHz	400K to 20 MHz	400K to 13.5 MHz

cathode bias power plays little part in determining ion flux since most of the rf power (typically an order of magnitude less than the source power) is used in accelerating ions. The combination of an inductive plasma source and a capacitive

[0144] More generally further, and when the etchant gases are a mixture of the halogen gas(es) (i.e., chlorine), the noble gas(es) (i.e., argon), and HBr and/or  $\text{BCl}_3$ , the process parameters for etching the platinum layer 316 in a suitable

inductively coupled plasma reactor, such as the inductively coupled plasma reactor **100** of **FIGS. 12 and 13** having the dielectric ceiling **110** illustrated in **FIG. 29**, fall into the ranges as listed on the basis of flow rates of the gases, including the halogen gas(es) (i.e.,  $\text{Cl}_2$ ) and the noble gas(es) (i.e., Ar) and HBr and/or  $\text{BCl}_3$ , as listed in Table II below:

(i.e., chlorine) and from about 35% by volume to about 45% by volume of the noble gas (i.e., argon) and from about 5% by volume to about 15% by volume of HBr and/or  $\text{BCl}_3$ . Thus, the foregoing process conditions stated in Tables I and II may be based on such etchant gas constituency and on such percent (%) by volume value(s).

TABLE II

Process Gas Flow, sccm	Broad	Preferred	Optimum
$\text{Cl}_2$	30 to 400	50 to 250	60 to 150
Ar	20 to 300	30 to 200	40 to 100
HBr and/or $\text{BCl}_3$	5 to 70	5 to 40	5 to 20
Pressure, mT	0.1 to 300	10 to 100	10 to 40
RF Power of Coil Inductor (Watts)	100 to 5000	650 to 2000	750 to 1000
RF Power of Wafer Pedestal (Watts)	50 to 3000	100 to 1000	150 to 400
Temperature of Wafer ( $^{\circ}\text{C}$ .)	about 20 to about 500	100 to 300	100 to 130
Temperature ( $^{\circ}\text{C}$ .) of Interior Surface of Dielectric Ceiling	about 150 to about 500	200 to 400	225 to 300
Platinum Etch Rate ( $\text{\AA}/\text{min}$ )	200 to 6000	500 to 3000	1000 to 2000
RF Frequency of Coil Inductor	100K to 300 MHz	400K to 20 MHz	2 to 13.5 MHz
RF Frequency of Wafer Pedestal	100K to 300 MHz	400K to 20 MHz	400K to 13.5 MHz

[0145] Therefore, the foregoing process conditions are preferably based on flow rates of etchant gas(es) having a flow rate value ranging from about 50 to about 500 sccm. As was previously mentioned, the etchant gas comprises or consists of or consists essentially of a halogen (preferably chlorine) and a noble gas selected from the group consisting of helium, neon, and argon. The noble gas is preferably argon. As was also previously mentioned, the etchant gas more specifically comprises or consists of or consists essentially of from about 20% by volume to about 95% by volume of the halogen gas (i.e., chlorine) and from about 5% by volume to about 80% by volume of the noble gas (i.e., argon); preferably from about 40% by volume to about 80% by volume of the halogen gas (i.e., chlorine) and from about 20% by volume to about 60% by volume of the noble gas (i.e., argon); more preferably from about 55% by volume to about 65% by volume of the halogen gas (i.e., chlorine) and from about 35% by volume to about 45% by volume of the noble gas (i.e., argon). In another preferred embodiment of the invention and as was previously mentioned, the etchant gas comprises, preferably consists of or consists essentially of, the halogen (i.e., chlorine), the noble gas (i.e., argon), and a gas selected from the group consists of HBr,  $\text{BCl}_3$  and mixtures thereof. The etchant gas more specifically comprises, or consists of or consists essentially of from about 10% by volume to about 90% by volume of the halogen gas (i.e., chlorine) and from about 5% by volume to about 80% by volume of the noble gas (i.e., argon) and from about 4% by volume to about 25% by volume of Br and/or  $\text{BCl}_3$ ; preferably from about 40% by volume to about 70% by volume of the halogen gas (i.e., chlorine) and from about 25% by volume to about 55% by volume of the noble gas (i.e., argon) and from about 5% by volume to about 20% by volume of HBr and/or  $\text{BCl}_3$ ; and more preferably from about 50% by volume to about 60% by volume of the halogen gas

[0146] After the platinum layer **316** has been etched to produce the platinum layers **316a**, **316b**, **316c** and **316d**, the residual mask layers **318r** (if not completely removed during the platinum etching process) typically remain on top of the etched platinum layers **316a**, **316b**, **316c** and **316d**, as best shown in **FIG. 32**. The residual mask layers **318r** are to be removed by any suitable means and/or in any suitable manner, such as by  $\text{CHF}_3/\text{Ar}$  plasma. After removal of residual mask layers **318r**, the etched platinum layered structure of **FIG. 33** remains. It should be noted, as best shown in **FIG. 34**, that the barrier layer **314** could be etched simultaneously during or after removal of the residual mask layers **318r** (see **FIG. 34**).

[0147] As was previously indicated, while the use of the embodiment of the invention in **FIG. 29** has been illustrated for platinum etching in an inductively coupled RF plasma reactor (e.g., inductively coupled plasma reactor **100** of **FIGS. 12 and 13**), it is to be understood that the spirit and scope of this preferred embodiment of the present invention includes heating the inside surface **6a** of the dielectric member **6** (e.g., interior surface **110a** of the dielectric ceiling **110**) for processing any metal with any other prior art plasma processing apparatuses (e.g., ECR source reactors, helicon source reactors, helical resonator reactors, etc.) employing other types of processing power (e.g., magnetron power, microwave power, etc.).

[0148] The invention will be illustrated by the following examples which set forth the currently known best mode and are presented by way of illustration only and not by way of any limitation. All parameters such as concentrations,

dimensions, mixing proportions, temperatures, pressure, rates, compounds, etc., submitted in this example are not to be construed to unduly limit the scope of the invention.

#### EXAMPLE I

[0149] The plasma processing apparatus for this Example was a Metal Etch DPS Centura™ brand plasma processing apparatus possessing a DPS™ brand chamber and sold by Applied Materials Inc., 3050 Bowers Avenue, Santa Clara, Calif. 95054-3299. The DPS™ brand chamber included an etch chamber and a generally hemispherical shaped standard dome as shown in FIG. 25 manufactured of a dielectric aluminum oxide that was capable of allowing RF power to pass therethrough for being coupled to a plasma of an etchant gas. The hemispherical shaped standard dome (hereinafter "Standard Dome") covered the etch chamber as a lid as represented in FIGS. 12 and 13 and sealed the chamber for pumping down to mTorr vacuum pressure. The inductive coils circled the outside of the hemispherical sloped dome and connected to a RF power supply. RF power energy delivered to the inductive coils were transmitted through the Standard Dome and into the DPS™ brand chamber and generated a high density plasma from a processing gas for processing semiconductor wafers.

[0150] The Standard Dome was tested with a plurality of 6-inch size aluminum wafers and with a plurality of 6-inch size SiO<sub>2</sub> wafers. The aluminum wafers were formulated with the following film stack:

75 μm Al/Si substrate

[0151] The SiO<sub>2</sub> wafers were formulated with the following film stack:

1 μm SiO<sub>2</sub>/Si Substrate

[0152] The processing gas was argon (Ar) and the approximate DPS™ brand chamber conditions for testing the Standard Dome were as follows:

Pressure, mTorr	7 to 10 mTorr
RF Power to Coil Inductor	500 to 1000 watts
RF Power to Wafer Pedestal	400 to 490 watts
RF Frequency of Coil Inductor	2 MHz
RF Frequency of Wafer Pedestal	13.56 MHz

[0153] The aluminum wafers were disposed in the DPS™ brand chamber and were etched for 5 minutes and subsequently removed therefrom. The SiO<sub>2</sub> wafers were then placed in the same DPS™ brand chamber, and were etched for 2 minutes and also subsequently removed therefrom. This alternating procedure of 5 minute etching of Al wafers followed by 2 minute etching of SiO<sub>2</sub> wafers was continuously repeated for about 100 minutes to monitor the affect of Al/SiO<sub>2</sub> by-product deposition on the inside surface of the Standard Dome vs. the etch rate on the SiO<sub>2</sub> wafers.

[0154] The process conditions (based on the flow rate of Ar) for the etching of the aluminum wafers were as follows:

Ar	75 sccm
Pressure	7 to 10 mTorr

-continued

Temperature of Wafer	110° C.
Aluminum Deposit Rate on Dome	300 Å/min.

[0155] The process conditions (also based on the flow rate of Ar) for the etching of SiO<sub>2</sub> wafers were as follows:

Ar	75 sccm
Pressure	7 to 10 mTorr
Temperature of Wafer	110° C.
SiO <sub>2</sub> Etch Rate on Wafer	1000 to 1400 Å/min.

[0156] Etch rates on the SiO<sub>2</sub> wafers were monitored to check the effect of Al/SiO<sub>2</sub> by-product conductive film deposition on the inside surface of the Standard Dome. If the Al/SiO<sub>2</sub> by-product conductive film deposition on the inside surface of the Standard Dome affects the RF power energy transmission from the coil inductor, a drop in the SiO<sub>2</sub> etch rate (i.e., Tox ER) would be observed. The test results obtained from the Standard Dome are shown in the Table I below:

TABLE I

RF-on Time (minutes)	Standard Dome, Tox ER (Å/min.)
0	1338
5	1271
10	1282
15	1333
20	1316
25	1272
30	1217
35	1225
40	1206
55	1106
60	
70	908
80	
85	788
100	783
110	

[0157] FIG. 27 is a plot of the results from Table I illustrating SiO<sub>2</sub> etch rate (Tox ER, Å/min.) vs. RF on-time, minutes. The FIG. 27 graph clearly shows that the SiO<sub>2</sub> etch rate began to precipitously decline after about 35 minutes of RF-on time because of the Al/SiO<sub>2</sub> by-product conductive film on the inside surface of the Standard Dome.

#### EXAMPLE II

[0158] Example I was repeated but with a Modified Dome and with 6-inch size platinum (Pt) wafers replacing the 6-inch size SiO<sub>2</sub> wafers. The Modified Dome for this Example II used the Standard DPS Dome from Example I, but whose inside surface had a plurality of braces secured thereto. FIGS. 26A, 26B and 26C are perspective views of the Modified Dome. Each brace supported a special metal piece. The first three assemblies (i.e., assemblies 4) in the side elevational view of FIG. 1 are representative of the manner in which the braces connected to the inside surface of the Modified Dome and of the manner in which the

special metal pieces connected to the braces. The special metal pieces were each approximately 5 cm×5 cm sq. and 0.03 cm thick. They were made of 5052 series aluminum with 0.0025 cm thick dielectric aluminum oxide on all the surfaces. The braces were made of aluminum and varied in length from about 0.02 cm to about 1.0 cm. The aluminum braces were attached to the inside surface of the standard DPS dome by high temperature adhesive glue. The metal pieces, as they were supported by the braces, overlapped each other and each made no contact with the other. The gap between all the metal pieces was about 0.05 cm. The overlap between all the metal pieces was about 0.5 cm.

[0159] The aluminum wafers were again 6-inch size and had the same film stack of: 75  $\mu\text{m}$  Al/Si substrate. The 6-inch size platinum wafers had the following film stack:

6000  $\text{\AA}$  Pt/300  $\text{\AA}$  TiN/5000  $\text{\AA}$  SiO<sub>2</sub>/Si substrate.

[0160] The processing gas was again argon (Ar) and the approximate DPS™ brand chamber conditions for testing the Modified Dome were the same as for the Standard Dome of Example I, which more particularly were as shown in Example I:

Pressure, mTorr	7 to 10 mTorr
RF Power to Coil Inductor	500 to 1000 watts
RF Power to Wafer Pedestal	400 to 490 watts
RF Frequency of Coil Inductor	2 MHz
RF Frequency of Wafer Pedestal	13.56 MHz

[0161] A similar alternating procedure employed for the Al wafers and SiO<sub>2</sub> wafers of Example I were repeated for the Al wafers and the Pt wafers of the present Example II. More specifically, the aluminum wafers were disposed in the DPS™ brand chamber and were etched for 20 minutes and subsequently removed. The platinum wafers were then placed in the same DPS™ brand chamber, and were etched for 30 seconds and subsequently removed. This alternating procedure of 20 minute etching of Al wafers followed by 30 seconds etching of Pt wafers was continually repeated for about 110 minutes to monitor the effect of the Al/Pt by-product deposition on the special metal pieces vs. the etch rate on the Pt wafers.

[0162] The process conditions (based on the flow rate of Ar) for the etching of the aluminum wafers were as follows:

Ar	75 sccm
Pressure	7 to 10 mTorr
Temperature of Wafer	110° C.
Aluminum Deposit Rate on Dome	300 $\text{\AA}/\text{min}$ .

[0163] The process conditions (also based on the flow rate of Ar) for the etching of platinum wafers were:

Ar	75 sccm
Pressure	7 to 10 mTorr
Temperature of Wafer	110° C.
Pt Etch Rate on Wafer	2000 to 2500 $\text{\AA}/\text{min}$ .

[0164] Etch rates on the Pt wafers were monitored to check the effect of Al/Pt conductive film deposition on the metal pieces which were coupled to the inside surface of the Modified Dome. If the Al/Pt conductive film deposition on the metal pieces affects the RF power energy transmission from the coil inductor, a drop in Pt etch rate on the Pt wafers would be observed. The test results obtained from the Modified Dome are shown in Table II below:

TABLE II

RF-on Time (minutes)	Modified Dome, Pt ER ( $\text{\AA}/\text{min}$ .)
0	2040
5	
10	
15	
20	2000
25	
30	
35	
40	1880
55	
60	1960
70	
80	1950
85	
100	1920
110	1940

[0165] FIG. 28 is a plot of the results from Table II illustrating the Pt etch rate vs. RF-on time, minutes. FIG. 28, as well as Table II above, illustrate that with the Modified Dome, there was no essential decrease in the Pt etch rate after about 100 minutes of RF-on time. The Al/Pt conductive film deposition on the metal pieces did not substantially affect the RF power energy transmission from the coil inductor through the Modified Dome and into the DPS™ brand chamber; thus, there was no substantial decrease in Pt etch rate on the Pt wafers. The fact that Pt wafers were used for this Example II instead of the SiO<sub>2</sub> wafers from Example I is more supportive of the fact that the overlapping and spaced special metal pieces provided and allowed a generally stable RF power transmission through the Modified Dome and into the DPS™ brand chamber because the Al/SiO<sub>2</sub> by-products deposited on the inside surface of the Standard Dome from Example I would not have been as conductive, and thus would not have been as an effective Faraday shield, as the Al/Pt by-products disposed on the special metal pieces of the Modified Dome. The Modified Dome provided a longer, more stable etch rate.

## EXAMPLE III

[0166] The plasma processing apparatus for this Example was a Metal Etch DPS Centura™ brand plasma processing apparatus possessing a DPS™ brand chamber and sold by Applied Materials Inc., 3050 Bowers Avenue, Santa Clara, Calif. 95054-3299. The DPS™ brand chamber included an etch chamber and a generally hemispherical shaped standard dome as shown in FIG. 25 manufactured of a dielectric aluminum oxide that was capable of allowing RF power to pass therethrough for being coupled to a plasma of an etchant gas. The hemispherical shaped standard dielectric dome (hereinafter "Standard Dome") covered the etch chamber as a lid as represented in FIGS. 12 and 13 and sealed the chamber for pumping down to mTorr vacuum

pressure. The inductive coils circled the outside of the hemispherical sloped dome and connected to a RF power supply. RF power energy delivered to the inductive coils were transmitted through the Standard Dome and into the DPS™ brand chamber and generated a high density plasma from a processing gas for processing semiconductor wafers.

[0167] Two experiments were conducted for analyzing conductive film deposits on the inside surface of the Standard Dome. A first experiment was conducted with the interior surface of the Standard Dome having a temperature (° C.) of about 80° C. A second experiment was conducted with the interior surface of the Standard Dome having a temperature (° C.) of about 150° C. The Standard Dome for each of the two experiments was heated with or by a lamp.

[0168] Two (2) sets of eighty-eight (88) 8-inch size platinum wafers were formulated for the two experiments with each set of platinum wafers having the following film stack:

0.5 μm SiO<sub>2</sub> (50% open)/0.2 μm Pt/0.03 μm TiN/1.0 μm SiO<sub>2</sub>/Si Substrate

[0169] The processing gases were Ar, Cl<sub>2</sub> and BCl<sub>3</sub> and the approximate DPS™ brand chamber conditions for each of the two experiments for analyzing conductive film deposits on the inside surface of the Standard Dome were as follows:

Pressure, mTorr	12 mTorr
RF Power to Coil Inductor	1200 watts
RF Power to Wafer Pedestal	150 watts
RF Frequency of Coil Inductor	2 MHz
RF Frequency of Wafer Pedestal	13.56 MHz

[0170] The process conditions (based on the flow rate of Cl<sub>2</sub>, Ar, and BCl<sub>3</sub>) for etching of the platinum wafers for each of the two experiments were as follows:

Cl <sub>2</sub>	60 sccm
Ar	40 sccm
BCl <sub>3</sub>	10 sccm
Pressure	12 mTorr
Temperature of Wafer	250° C.
Platinum Etch Rate	1000 Å/min.

[0171] The first set of eighty-eight (88) platinum wafers were disposed in the DPS™ brand chamber and were etched for about 2.5 minutes per wafer while the interior surface of the Standard Dome had a temperature of about 80° C. A conductive film deposit formed on the 80° C. interior surface of the Standard Dome.

[0172] The second set of eighty-eight (88) platinum wafers were disposed in the DPS™ brand chamber and were etched for about 2.5 minutes per wafer while the interior surface of the Standard Dome had a temperature of about 150° C. A conductive film deposit formed on the 150° C. interior surface of the Standard Dome.

[0173] The impedance of the respective conductive film deposits formed on the 80° C. interior surface and on the 150° C. interior surface of the Standard Dome were measured with a HP vector impedance meter. The compositions of each of the conductive film deposits were determined by

XPS(ESCA), XRD and EDS, and the deposition thickness for each were determined qualitatively.

[0174] XPS (ESCA) is an electron spectroscopy for chemical analyses. It is more specifically an energy analysis of photoelectrons generated by X-ray irradiation, including sputtering with an auxiliary ion beam. XPS (ESCA) is particularly suited for major and minor elemental identification and chemical bonding information at the surface, including selected element depth profiling in thin films, particularly insulators. XRD, X-ray Diffraction, is an angular distribution analysis of constructively or destructively interfering X-rays scattered from solids. XRD is a phase identification, a measurement of lattice parameter, stress, average crystallite size and preferred orientation on crystalline solids and thin films, and a measurement of thickness and density of thin films. EDS or SEM/EDX (Scanning Electron Microscopy/Energy Dispersive X-ray Spectroscopy) employs irradiation by a focused electron beam, including imaging of secondary or backscattered electrons and energy analysis of X-rays. EDS is plan view and cross-sectional surface imaging and compositional analysis of thin films for carbon and heavier elements.

[0175] The following Table summarizes the results for the two experiments.

Dome Temperature	Impedance MagDPhase	XPS	XRD	EDS Pt/Cl Deposition Ratio Thickness
80° C.	1800 ohm D-420	PtCl2	Pt, PtCl2, PtO2	0.8 Thick
150° C.	480 ohm D-90	Pt, PtCl2, PtO2	PT, PtCl14, PtO2	0.9 Very Thin

[0176] The skin depth and impedance of the conductive film deposit for the 80° C. dome temperature experiment was greater than the skin depth and impedance of the conductive film deposit for the 150° C. dome temperature experiment. Therefore, the electrical conductivity of the conductive film deposit for the 80° C. dome temperature experiment was less than the electrical conductivity of the conductive film deposit for the 150° C. dome temperature experiment. Thus, as the thickness (i.e., skin depth) of a conductive film decreases, the associated conductivity increases, particularly when the temperature of the interior surface of Standard Dome increases. Stated alternatively, the thickness (i.e., skin depth) of the conductive film deposit decreases as the temperature of the interior surface of the dielectric member (i.e., the dielectric Standard Dome) increases. At higher temperatures for the interior surface for the Standard Dome there would be essentially no conductive film deposit on the interior surface thereof.

Conclusion

[0177] Therefore, by the practice of the present invention there is provided an assembly 4 for allowing stable power transmission into a plasma processing chamber. The material deposition support members 8 of the assembly 4 receive and support the deposition of materials (i.e., deposit 7 of materials) which are electrical conductive by-products from

processing (e.g., metal etching) of a substrate (i.e., semiconductor wafer **13**) in a process chamber having a controlled environment in containing a plasma of a processing gas. There is also provided a liner assembly **11** having a plurality of assemblies **4** secured thereto. The assembly **4** prevents the deposition of materials on the dielectric member **6** (e.g., dielectric window or ceiling **110**) from becoming generally continuous during processing of the semiconductor wafer **13** in a process chamber and generally allows waves of power energy to pass uninterruptedly through the dielectric member **6**. By the practice of the present invention there is also provided a plasma reactor for processing substrates, more particularly an inductively coupled RF plasma reactor for processing semiconducting wafers. By the further practice of the present invention there is provided a method for adjusting the density of plasma contained within a process chamber wherein substrates are to be processed. A method of processing a metal layer disposed on a substrate is also provided by the practice of the present invention.

**[0178]** By the practice of the present invention there is also further provided a method for processing a metal layer, such as etching of the platinum layer **316**. When the dielectric member (e.g., the dielectric ceiling **110** of **FIG. 29**) is heated such that an interior surface of the dielectric member (e.g., interior surface **110a** of the dielectric ceiling **100**) has a temperature greater than about 150° C., essentially no deposit forms on the interior surface of the dielectric member. Because no deposit is formed when the interior surface of the dielectric member is heated above 150° C., a stable power transmission is allowed to pass through the dielectric member and into a plasma processing chamber.

**[0179]** Thus, while the present invention has been described herein with reference to particular embodiments thereof, a latitude of modification, various changes and substitutions are intended in the foregoing disclosure, and it will be appreciated that in some instances some features of the invention will be employed without a corresponding use of other features without departing from the scope and spirit of the invention as set forth. Therefore, many modifications may be made to adapt a particular situation or material to the teachings of the invention without departing from the essential scope and spirit of the present invention. It is intended that the invention not be limited to the particular embodiment(s) disclosed as the best mode contemplated for carrying out this invention, but that the invention will include all embodiments and equivalents falling within the scope of the appended claims.

What is claimed is:

1. A method of processing a metal layer on a substrate comprising the steps of:

- a) providing a substrate;
- b) disposing said substrate in a chamber including a chamber wall and a dielectric member supported by the chamber wall;
- c) introducing a processing gas into the chamber of step (b);
- d) passing processing power through the dielectric member and into the chamber of step (b) for processing a metal layer on the substrate in a plasma of the processing gas and to produce processing power-blocking

materials which are capable of depositing on the dielectric member and reducing the efficiency of processing power passing through the dielectric member and into the plasma within the chamber; and

e) essentially preventing the processing power-blocking materials from depositing on the dielectric member.

2. The method of claim 1 wherein said essentially preventing step (e) comprises heating a surface of the dielectric member to a temperature which essentially prevents the processing power-blocking materials from depositing on the surface of the dielectric member.

3. The method of claim 1 wherein said processing power-blocking materials include a capability of forming on a surface of the dielectric member a deposit whose conductivity increases as the thickness of the deposit decreases.

4. The method of claim 2 wherein said processing power-blocking materials include a capability of forming on a surface of the dielectric member a deposit whose conductivity increases as the thickness of the deposit decreases when the temperature of the dielectric member increases.

5. The method of claim 1 wherein said processing power-blocking materials comprise electrically conductive products.

6. The method of claim 2 wherein said processing power-blocking materials comprise electrically conductive products.

7. The method of claim 4 wherein said processing power-blocking materials comprise electrically conductive products.

8. The method of claim 2 wherein said temperature is greater than about 150° C.

9. The method of claim 4 wherein said temperature is greater than about 225° C.

10. The method of claim 1 wherein said processing power-blocking material comprises an element selected from the group consisting of platinum, copper, aluminum, titanium, ruthenium, iridium and mixtures thereof.

11. The method of claim 1 wherein said substrate including said metal layer comprises a semiconductor wafer.

12. The method of claim 1 wherein said dielectric member includes a generally dome-shaped structure.

13. The method of claim 12 wherein said processing power is selected from the group consisting of RF power, magnetron power, microwave power, and mixtures thereof.

14. The method of claim 1 wherein said chamber includes an inductively coupled RF plasma of the processing gas.

15. The method of claim 1 wherein said processing of said metal layer on the substrate is selected from the group consisting of etching said metal layer and depositing said metal layer.

16. The method of claim 3 wherein said processing power-blocking materials comprise platinum, and said processing of said metal layer comprises etching a platinum layer.

17. A method for preventing a deposit of materials whose conductivity increases as the thickness of the deposit decreases comprising:

- a) providing a chamber including a chamber wall supporting a dielectric member and containing at least one substrate and a plasma processing gas for processing at least one substrate;
- b) introducing processing power through a dielectric member and into the chamber for processing the sub-

strate and producing materials which are capable of forming a deposit on a surface of the dielectric member wherein the deposit would include a conductivity which increases as the thickness of the deposit decreases; and

c) heating the surface of the dielectric member to a temperature greater than about 150° C. to essentially prevent the produced materials from depositing on the surface of the dielectric member.

**18.** The method of claim 17 wherein said produced materials comprise electrically conductive products.

**19.** The method of claim 17 wherein said processing power is selected from the group consisting of RF power, magnetron power, and mixtures thereof.

**20.** The method of claim 17 wherein said processing power is selected from the group consisting of microwave power, magnetron power, and mixtures thereof.

**21.** The method of claim 17 wherein said produced materials comprise an element selected from the group consisting of platinum, copper, aluminum, titanium, ruthenium, iridium and mixtures thereof.

**22.** The method of claim 18 wherein said produced materials comprise an element selected from the group consisting of platinum, copper, aluminum, titanium, ruthenium, iridium and mixtures thereof and said deposit would include a conductivity which increases as the thickness of the deposit decreases when the temperature of the surface of the dielectric member increases.

**23.** The method of claim 17 wherein said processing of the substrate comprises processing a metal layer on the substrate.

**24.** The method of claim 23 wherein said substrate comprises a semiconductor wafer.

**25.** The method of claim 17 wherein said dielectric member includes a generally dome-shaped structure.

**26.** The method of claim 25 wherein said processing power is selected from the group consisting of RF power, magnetron power, microwave power, and mixtures thereof.

**27.** The method of claim 17 wherein said chamber includes an inductively coupled RF plasma of the processing gas.

**28.** The method of claim 23 wherein said processing of said metal layer is selected from the group consisting of etching said metal layer and depositing said metal layer.

**29.** The method of claim 23 wherein said processing power-blocking materials comprise platinum, and said processing of said metal layer comprises etching a platinum layer.

**30.** A method of etching a platinum layer disposed on a substrate comprising the steps of:

a) providing a substrate supporting a platinum layer;

b) disposing the substrate of step (a) in a chamber including a chamber wall supporting a dielectric member and containing a processing gas;

c) heating an interior surface of the dielectric member to a temperature to essentially prevent platinum by-products produced from etching the platinum layer in a plasma of the processing gas from forming a deposit on the interior surface of the dielectric member and reduce the efficiency of processing power passing through the dielectric member and into the plasma of the processing gas; and

d) etching the platinum layer in a plasma of the processing gas to produce an etched platinum layer and said platinum by-products of step (c) without any of said platinum by-products forming a deposit on the interior surface of the dielectric member.

**31.** The method of claim 30 wherein said etching step (d) comprises transmitting processing power through the dielectric member and into the plasma processing gas with essentially no reduction in efficiency of processing power passing through the dielectric member and into the plasma processing gas.

**32.** The method of claim 30 wherein said temperature of step (c) is greater than about 150° C.

**33.** The method of claim 31 wherein said temperature of step (c) is greater than about 150° C.

**34.** The method of claim 30 wherein said platinum by-products of step (d) comprise electrically conductive products.

**35.** The method of claim 33 wherein said platinum by-products of step (d) comprise electrically conductive products.

**36.** The method of claim 30 wherein said platinum by-products of step (d) are capable of forming a deposit having a conductivity which increases as the thickness of the deposit decreases.

**37.** The method of claim 35 wherein said platinum by-products of step (d) are capable of forming a deposit having a conductivity which increases as the thickness of the deposit decreases when the temperature of the interior surface of the dielectric member increases.

**38.** The method of claim 30 wherein said processing gas of said plasma of step (d) is selected from the group consisting of argon, oxygen, chlorine and mixtures thereof.

\* \* \* \* \*