



(12) **United States Design Patent**
Strohman

(10) **Patent No.:** **US D959,968 S**

(45) **Date of Patent:** **** *Aug. 9, 2022**

(54) **EXTRUDED TRACK**

(71) Applicant: **Gorbel, Inc.**, Fishers, NY (US)

(72) Inventor: **Benjamin A. Strohman**, Rochester, NY (US)

(73) Assignee: **Gorbel, Inc.**, Fishers, NY (US)

(*) Notice: This patent is subject to a terminal disclaimer.

(**) Term: **15 Years**

(21) Appl. No.: **29/702,896**

(22) Filed: **Aug. 22, 2019**

(51) **LOC (13) Cl.** **08-05**

(52) **U.S. Cl.**

USPC **D8/377**

(58) **Field of Classification Search**

USPC D8/376-377, 373, 363-365, 354, 356;
D25/119-121, 124-127, 133-134, 136,
D25/38.1, 41.1, 43; D6/580-581, 711,
D6/524, 546-547, 550, 556, 554, 512,
D6/327, 324

CPC ... E04F 10/06; E04F 10/0603; E04F 10/0681;
E04F 10/0685; E04F 19/00; E04F 19/02;
E04F 19/04; A47F 1/12; A47F 5/005

See application file for complete search history.

(56) **References Cited**

U.S. PATENT DOCUMENTS

D335,624 S *	5/1993	Siener	D25/123
D417,607 S *	12/1999	Vining	D25/119
D419,858 S *	2/2000	Bosgoed	D25/121
D488,055 S *	4/2004	Ter Braak	D8/377
D589,724 S *	4/2009	Howe	D25/126
D600,364 S *	9/2009	Boardman	D25/133
D600,831 S *	9/2009	Munakata	D25/126
D662,403 S *	6/2012	Page	D8/377
D669,769 S *	10/2012	Lapping	D8/377

D670,946 S *	11/2012	Ng	D6/580
D728,826 S *	5/2015	Cyphers	D25/38.1
D734,495 S *	7/2015	Walde	D25/38.1
D745,299 S *	12/2015	Chang	D6/709
D747,127 S *	1/2016	Chang	D6/709
D754,366 S *	4/2016	Morton	D25/124
D764,378 S *	8/2016	Conrad	D12/317
D764,379 S *	8/2016	Conrad	D12/317
D811,204 S *	2/2018	Weldon	
D852,378 S *	6/2019	Springborn	D25/38.1
D852,379 S *	6/2019	Springborn	D25/38.1
D852,380 S *	6/2019	Springborn	D25/38.1
D852,381 S *	6/2019	Springborn	D25/38.1
D852,382 S *	6/2019	Springborn	D25/38.1
D854,855 S *	7/2019	Garcia Garcia	D6/580

(Continued)

Primary Examiner — Sandra Snapp

Assistant Examiner — Elizabeth Sun Ko

(74) *Attorney, Agent, or Firm* — Duane C. Basch; Basch & Nickerson LLP

(57) **CLAIM**

The ornamental design for an extruded track, as shown and described.

DESCRIPTION

FIG. 1 is a top perspective view of the top, front and right side of an extruded track;

FIG. 2 is a front view thereof;

FIG. 3 is a right side view thereof;

FIG. 4 is a rear view thereof;

FIG. 5 is a left side view thereof;

FIG. 6 is a top view thereof;

FIG. 7 is a bottom view thereof; and,

FIG. 8 is a bottom perspective view of the bottom, front and left side.

The claimed design is shown with dashed symbolic break lines in its length. The appearance of any portion of the extruded track between the symbolic break lines forms no part of the claimed design.

1 Claim, 8 Drawing Sheets

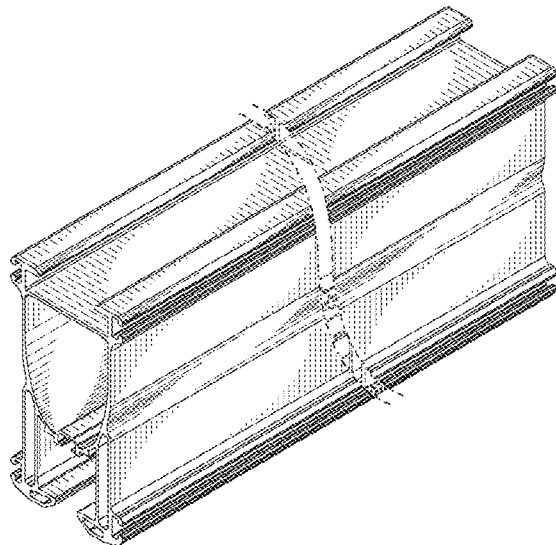

(56)

References Cited

U.S. PATENT DOCUMENTS

D854,856	S	*	7/2019	Garcia Garcia	D6/580
D901,938	S	*	11/2020	Haapalahti	D6/580
D909,618	S	*	2/2021	Zhao	D25/121
D915,283	S	*	4/2021	Steining	D13/128
D917,731	S	*	4/2021	Nelson	D25/124
D920,769	S	*	6/2021	Kovacs	D8/377
D922,615	S	*	6/2021	Springborn	D25/38.1

* cited by examiner

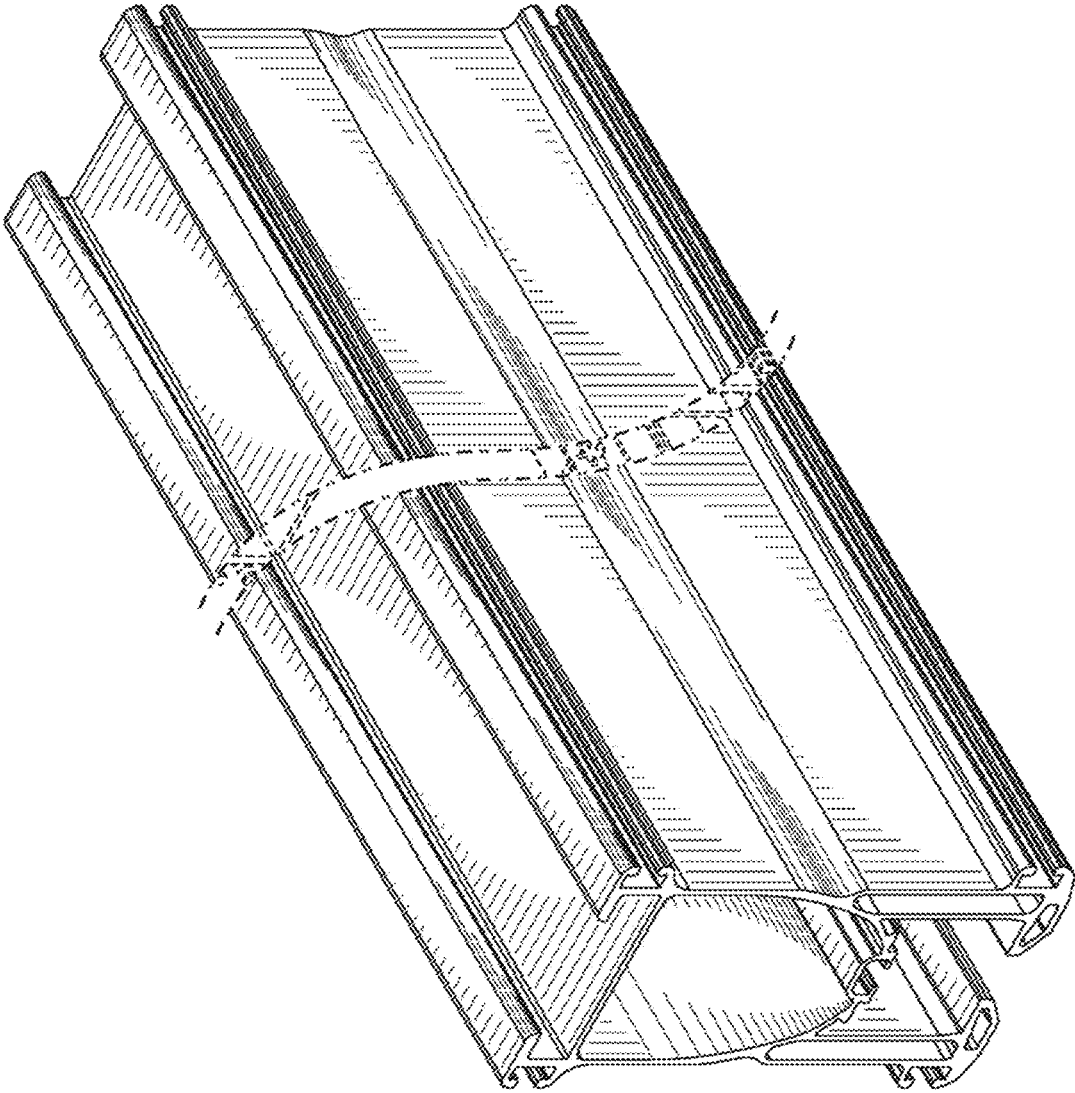

FIG. 1

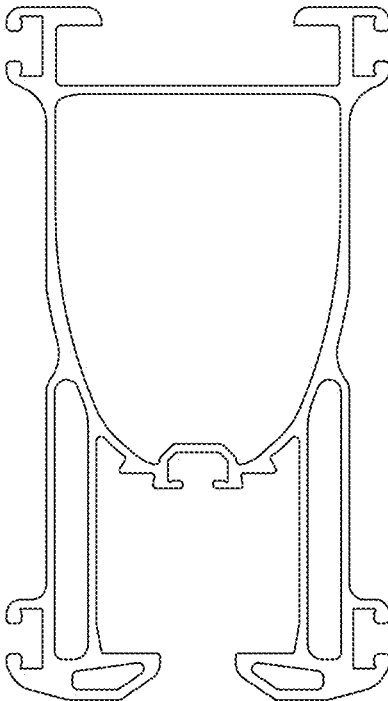

FIG. 2

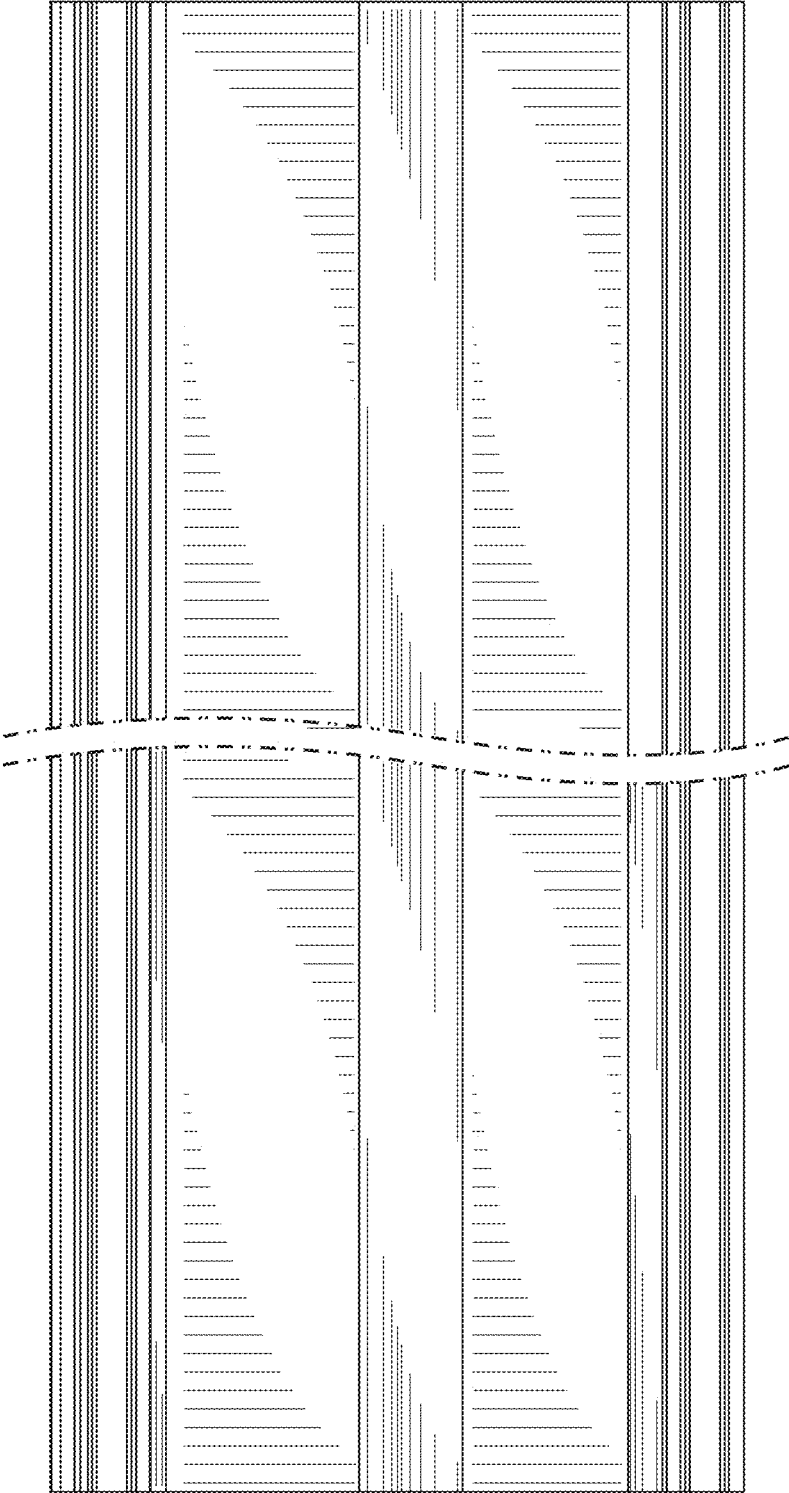

FIG. 3

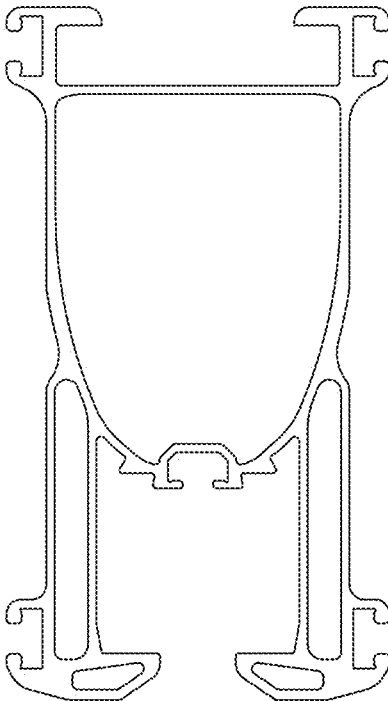

FIG. 4

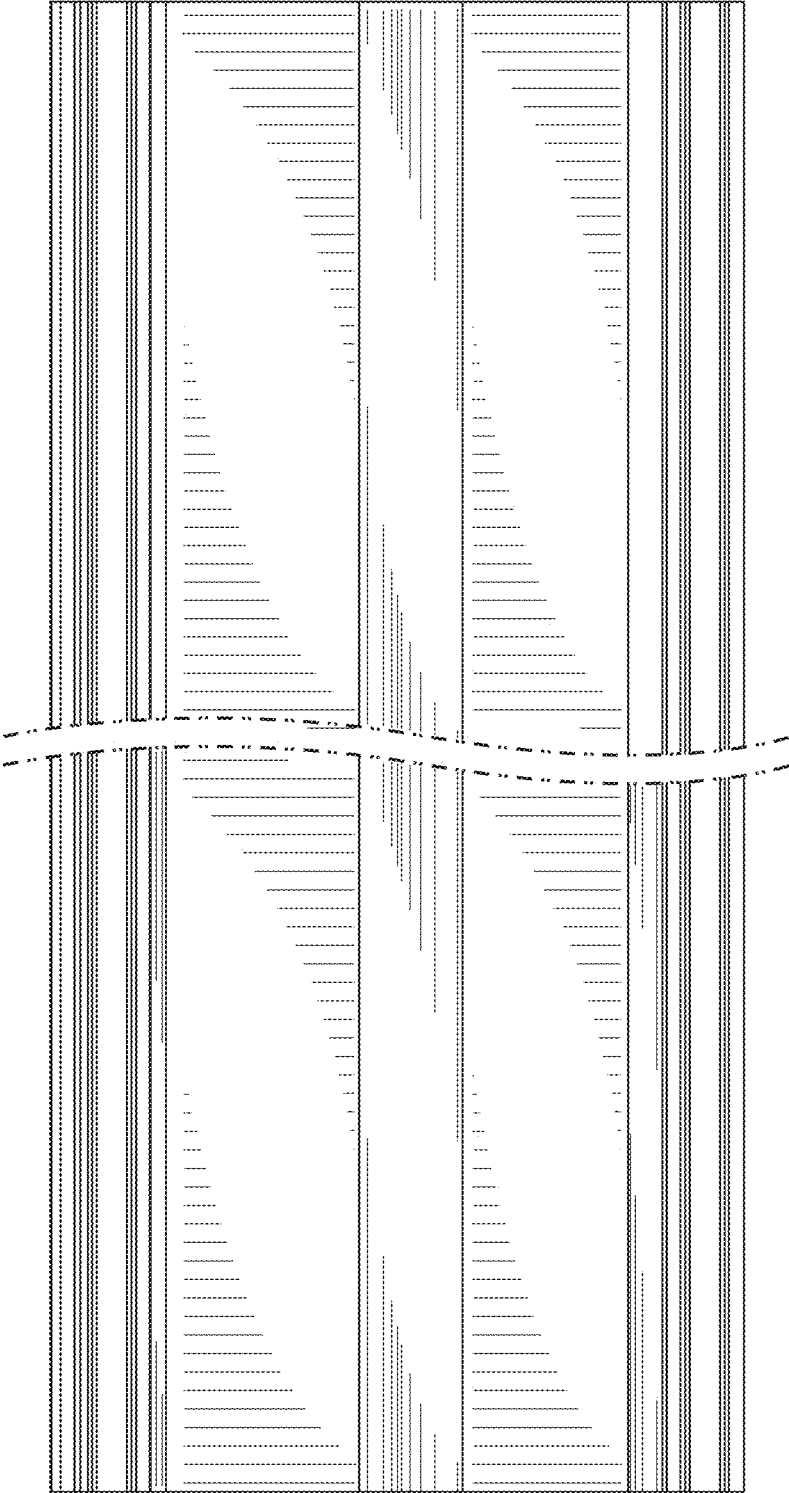

FIG. 5

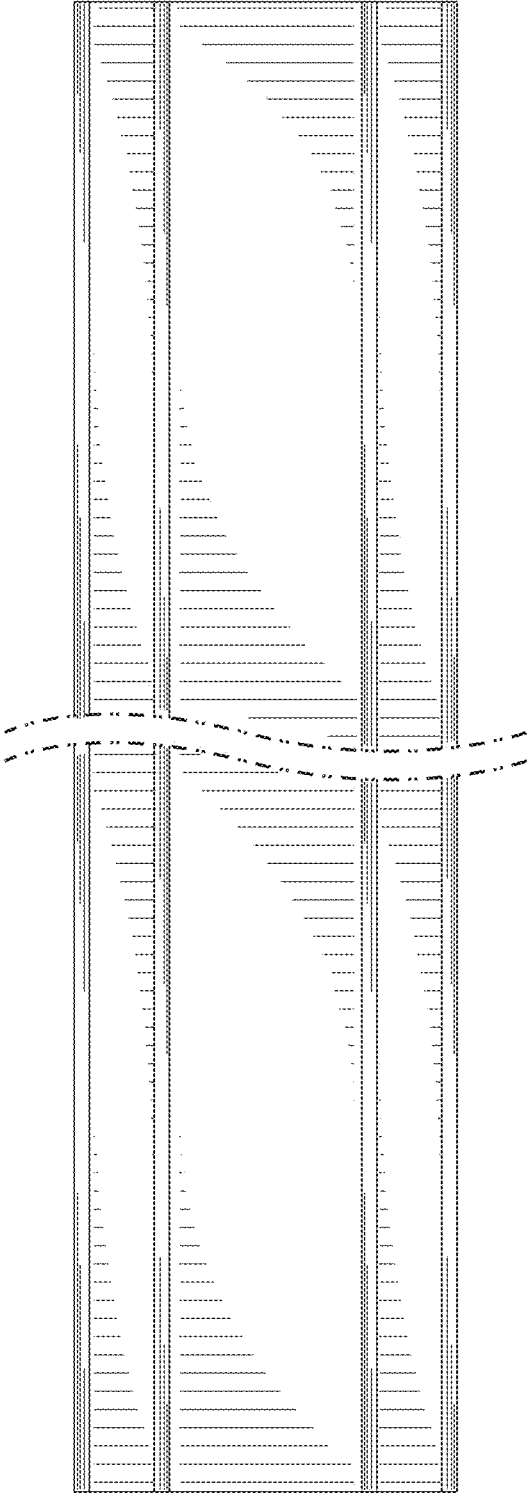

FIG. 6

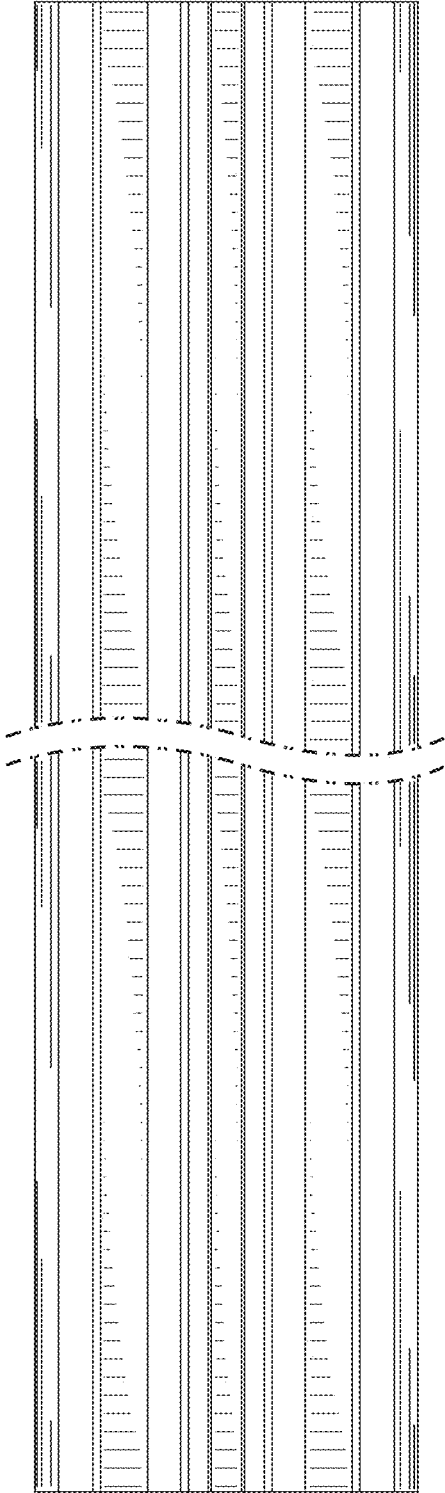

FIG. 7

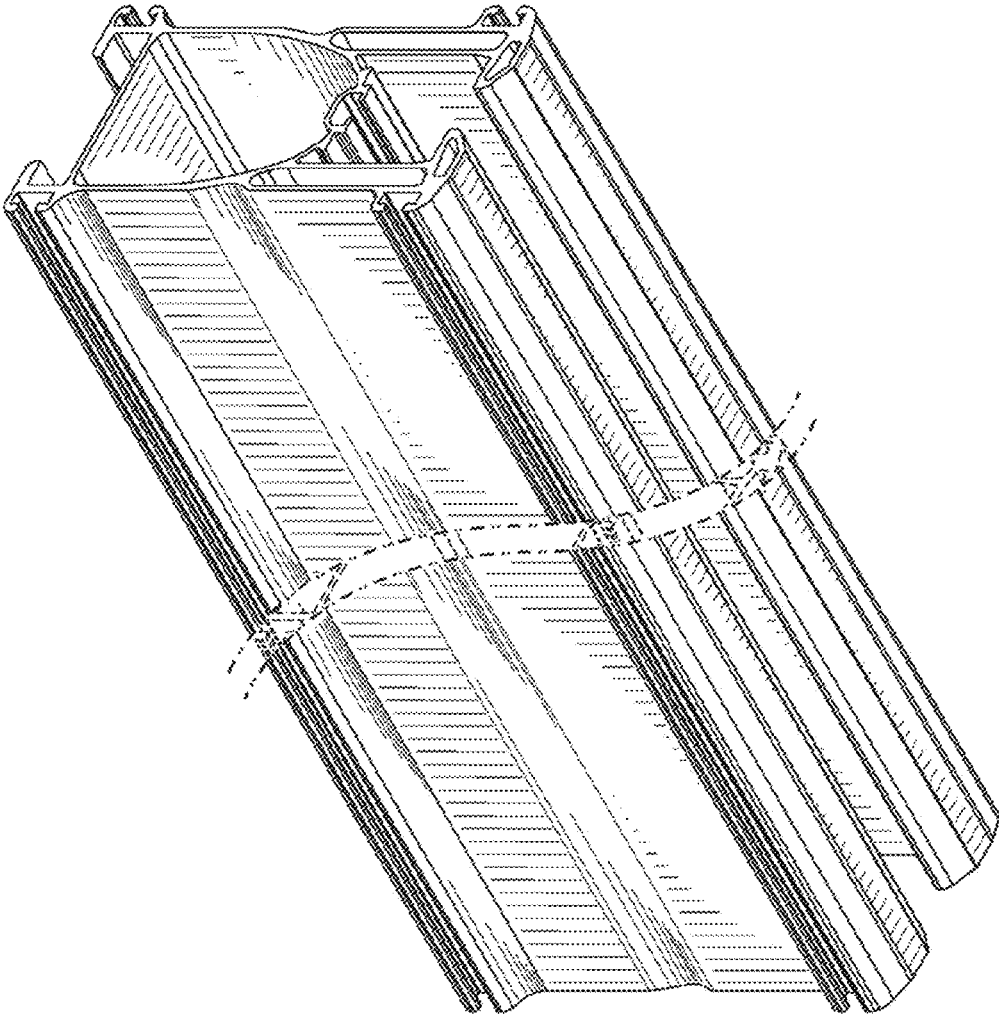

FIG. 8