

(19) World Intellectual Property Organization
International Bureau



(43) International Publication Date
28 December 2006 (28.12.2006)

PCT

(10) International Publication Number
WO 2006/137874 A2

- (51) International Patent Classification:
F41A 5/00 (2006.01)
- (21) International Application Number:
PCT/US2005/033529
- (22) International Filing Date:
19 September 2005 (19.09.2005)
- (25) Filing Language: English
- (26) Publication Language: English
- (30) Priority Data:
60/610,703 17 September 2004 (17.09.2004) US
Not furnished 19 September 2005 (19.09.2005) US
- (71) Applicant (for all designated States except US): **COLT DEFENSE LLC** [US/US]; 545 New Park Avenue, Hartford, CT 06110 (US).
- (72) Inventors: **KUCZYNSKO, Grzegorz**; 85 Burlington Road, Unionville, CT 06085-1376 (US). **DORSEY, Josh**; 13 Bears Den Way, Columbia, CT 06237 (US).
- (74) Agents: **GREEN, Clarence, A.** et al.; Perman & Green, LLP, 425 Post Road, Fairfield, CT 06824 (US).

- (81) Designated States (unless otherwise indicated, for every kind of national protection available): AE, AG, AL, AM, AT, AU, AZ, BA, BB, BG, BR, BW, BY, BZ, CA, CH, CN, CO, CR, CU, CZ, DE, DK, DM, DZ, EC, EE, EG, ES, FI, GB, GD, GE, GH, GM, HR, HU, ID, IL, IN, IS, JP, KE, KG, KM, KP, KR, KZ, LC, LK, LR, LS, LT, LU, LV, LY, MA, MD, MG, MK, MN, MW, MX, MZ, NA, NG, NI, NO, NZ, OM, PG, PH, PL, PT, RO, RU, SC, SD, SE, SG, SK, SL, SM, SY, TJ, TM, TN, TR, TT, TZ, UA, UG, US, UZ, VC, VN, YU, ZA, ZM, ZW.
- (84) Designated States (unless otherwise indicated, for every kind of regional protection available): ARIPO (BW, GH, GM, KE, LS, MW, MZ, NA, SD, SL, SZ, TZ, UG, ZM, ZW), Eurasian (AM, AZ, BY, KG, KZ, MD, RU, TJ, TM), European (AT, BE, BG, CH, CY, CZ, DE, DK, EE, ES, FI, FR, GB, GR, HU, IE, IS, IT, LT, LU, LV, MC, NL, PL, PT, RO, SE, SI, SK, TR), OAPI (BF, BJ, CF, CG, CI, CM, GA, GN, GQ, GW, ML, MR, NE, SN, TD, TG).

Published:
— without international search report and to be republished upon receipt of that report

For two-letter codes and other abbreviations, refer to the "Guidance Notes on Codes and Abbreviations" appearing at the beginning of each regular issue of the PCT Gazette.

(54) Title: FIREARM HAVING AN INDIRECT GAS OPERATING SYSTEM

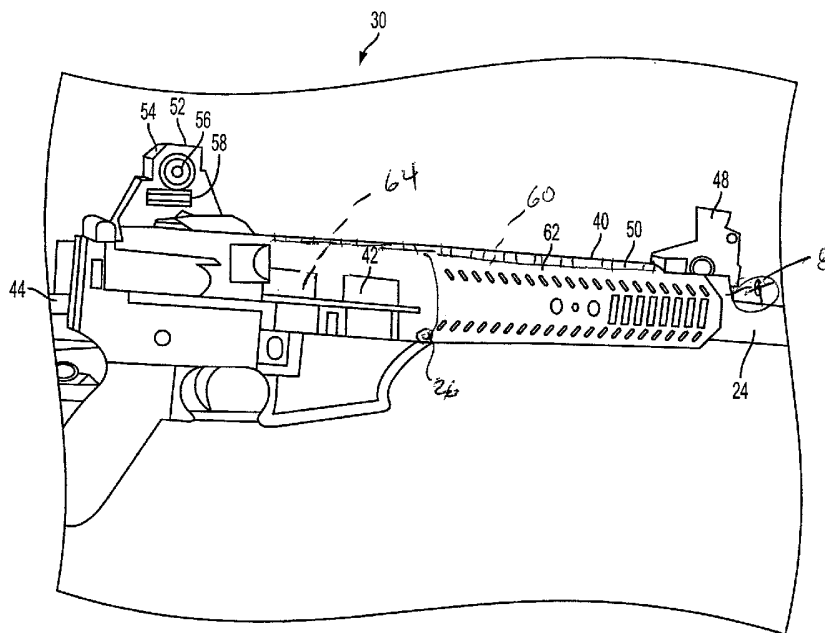

(57) Abstract: An M4 type automatic or semi-automatic firearm having an indirect gas operating system. A bolt assembly has a striking surface. The bolt assembly is enclosed within an M4 type receiver assembly. A barrel assembly having a bore is coupled to the receiver assembly. A gas block having a cylinder is fitted to the barrel assembly with the cylinder in communication with the bore. A piston and rod assembly has a piston and a striking rod, with the piston fitted to the cylinder. Gas discharged from a fired cartridge displaces the piston and causes the striking rod to strike the striking surface displacing the bolt assembly.

WO 2006/137874 A2

FIREARM HAVING AN INDIRECT GAS OPERATING SYSTEM

This application claims the benefit of U.S. Provisional Application No. 60/610,703, filed September 17, 2004 and hereby incorporated by reference in its entirety.

BACKGROUND

[001] 1. Field of the Disclosed Embodiments

[002] The disclosed embodiments relate to firearms and, more particularly, to a firearm having an indirect gas operating system.

[003] 2. Brief Description of Related developments

[004] Combat firearms employ various methods to eject spent and reload unfired cartridges in semi automatic or automatic operation. Such methods may employ gas resulting from a discharged cartridge whereby the bolt assembly is displaced by action of the gas. A problem arises when a user deploys such a system where the firing rate is fixed resulting in either an excessive rate of cartridge consumption or insufficient firing rate. Accordingly, there is a desire to provide a variable firing rate semi automatic or automatic firearm.

[005] SUMMARY OF THE EXEMPLARY EMBODIMENTS

[006] In accordance with one exemplary embodiment, an M4 type automatic or semi-automatic firearm having an indirect gas operating system is provided. The firearm comprises a bolt assembly having a striking surface with the bolt assembly enclosed within an M4 type receiver assembly. A barrel assembly having a bore is coupled to the receiver assembly. A gas block having a cylinder is fitted to the

barrel assembly with the cylinder in communication with the bore. A piston and rod assembly having a piston and a striking rod has the piston fitted to the cylinder. Gas discharged from a fired cartridge displaces the piston and causes the striking rod to strike the striking surface displacing the bolt assembly.

[007] In accordance with another exemplary embodiment, an automatic or semi-automatic firearm having an indirect gas operating system is provided. The firearm has a bolt assembly enclosed within a receiver and a barrel assembly having a bore and coupled to the receiver. A cylinder is fitted to barrel assembly with the cylinder in communication with the bore via an intermediate regulator. A piston assembly has a piston end and a striking end, the piston end fitted to the cylinder. Gas discharged from a fired cartridge displaces the piston and causes the striking end to displace the bolt assembly. The intermediate regulator regulates the flow of the gas from the bore to the piston.

[008] In accordance with another exemplary embodiment, an automatic or semi-automatic firearm having an indirect gas operating system is provided. The firearm has a bolt assembly enclosed within a receiver. A barrel assembly has a bore and coupled to the receiver. A cylinder is fitted to the barrel assembly with the cylinder in communication with the bore via an intermediate regulator. A piston assembly has a piston end and a striking end, with the piston end fitted to the cylinder. The intermediate regulator has two selectable positions corresponding to two selectable firing rates. Gas discharged from a fired cartridge displaces the piston and causes the striking end to displace the bolt

assembly. The intermediate regulator regulates the flow of the gas from the bore to the piston. The intermediate regulator may be switched between the two selectable positions by an operator without the use of tools.

BRIEF DESCRIPTION OF THE DRAWINGS

- [0009]** The foregoing aspects and other features of the exemplary embodiments are explained in the following description, taken in connection with the accompanying drawings, wherein:
- [0010]** Fig. 1 is a side elevation view of an automatic firearm incorporating features in accordance with an exemplary embodiment;
- [0011]** Fig. 2 is a partial top isometric view of the front sight section of the firearm shown in Fig. 1;
- [0012]** Fig. 3 is a partial isometric view of the front sight section of the firearm shown in Fig. 1;
- [0013]** Fig. 4A is an exploded view of the front sight section of the firearm shown in Fig. 1, and Fig. 4B is a bottom view of a base of the front sight station;
- [0014]** Fig. 5 is another exploded view of the front sight section showing the portions of the front sight section as seen from another direction;
- [0015]** Figs. 6A-6C are respectively different side elevation views and a cross sectional view of a sight portion of the front sight section of the firearm shown in Fig. 1;

- [0016] Figs. 7A-7C are respectively opposite end elevation views and a side elevation is a view of a base portion of the front sight section of the firearm shown in Fig. 1;
- [0017] Fig. 8 is an enlarged side elevation view of the base portion of the front sight section of the firearm shown in Fig. 1;
- [0018] Figs. 9A-9B are respectively a cross-section of a threaded cap and a side view of a of the front sight section of the firearm shown in Fig. 1;
- [0019] Fig. 10 is a side elevation view of the firearm shown in Fig. 1 with the hand guard removed;
- [0020] Fig. 11 is an enlarged partial side elevation view of the firearm shown in Fig. 1 with the hand guard removed;
- [0021] Fig. 12 is another enlarged partial side elevation view of the firearm shown in Fig. 1 with the hand guard removed;
- [0022] Fig. 13 is an exploded view of an automatic firearm incorporating features in accordance with an exemplary embodiment;
- [0023] Fig. 14 is a side exploded view of a barrel, receiver, hand guard and gas piston assembly;
- [0024] Figs. 15 is a side exploded view of a gas piston assembly and Fig. 15A is an exploded end view of the gas block;
- [0025] Fig. 16 is a schematic perspective view of another portion of the gas piston assembly;
- [0026] Fig. 17 is a side exploded view of a portion of a gas piston assembly;

- [0027] Fig. 18 is a side view of the portion of the gas piston assembly seen in Fig. 17;
- [0028] Fig. 19 is a side view of an operating rod of the gas piston assembly;
- [0029] Fig. 20 is a side view of still another of the gas piston assembly;
- [0030] Fig. 21 is a partial side view of the firearm showing a portion of a gas piston assembly in accordance with another exemplary embodiment;
- [0031] Fig. 22 is another partial side view of the gas piston assembly in Fig. 21 with the cyclic selector in a different position;
- [0032] Fig. 23 is an exploded view of the gas piston assembly in Fig. 21;
- [0033] Fig. 24 is a perspective view of the gas block in Fig. 23;
- [0034] Fig. 25 is a perspective view of the selector of the gas piston assembly in Fig. 23;
- [0035] Fig. 26 is another perspective view of the selector of the piston assembly;
- [0036] Fig. 27 is another exploded view of the gas block and selector of the piston assembly;
- [0037] Fig. 28 is a section view of a gas piston assembly and firearm barrel;
- [0038] Fig. 29 is another section view of a gas piston assembly and firearm barrel;

- [0039] Fig. 30A is a bottom view of a receiver assembly in accordance with an exemplary embodiment and Fig. 30B is a bottom view of a conventional recess assembly;
- [0040] Fig. 31A is a top view of the receiver assembly and Fig. 31B is a top view of a conventional receiver assembly;
- [0041] Fig. 32A is an elevation view of a bolt carriage assembly and Fig. 32B is an elevation view of a conventional bolt carriage;
- [0042] Figs. 33 and 33A-33B are respectively a perspective view and different exploded views of the bolt carriage assembly;
- [0043] Fig. 34 is a section view of a portion of the bolt carriage assembly;
- [0044] Fig. 35 is a side elevation view of a hand guard assembly of the firearm in accordance with an exemplary embodiment;
- [0045] Fig. 36 is a top plan view of the hand guard assembly in Fig. 35;
- [0046] Fig. 37 is another side elevation view of the hand guard assembly;
- [0047] Fig. 38 is a side elevation view of the hand guard and removed rails;
- [0048] Fig. 39 is an isometric view of a front end of the hand guard;
- [0049] Fig. 40 is an elevation view of the barrel of the firearm and radiator assembly in accordance with another

exemplary embodiment, the radiator being shown in assembled and disassembled conditions; and

[0050] Fig. 41 is an elevation view of the barrel and radiator assembly where the radiator assembly is removed from the barrel, the radiator assembly portions being positioned to show outer and inner surfaces.

[0051] DETAILED DESCRIPTION OF THE EXEMPLARY EMBODIMENT(S)

[0052] Referring to Fig. 1, there is shown, a side elevation view of an automatic firearm 30 capable of automatic or semiautomatic fire incorporating features in accordance with an exemplary embodiment. Although the present invention will be described with reference to the embodiments shown in the drawings, it should be understood that the present invention can be embodied in many alternate forms of embodiments. In addition, any suitable size, shape or type of elements or materials could be used.

[0053] Firearm 30 is illustrated as generally having an M4 or M16 type automatic firearm configuration. However, the features of the disclosed embodiments, as will be described below, are equally applicable to any desired type of automatic firearm. Firearm 30 may have operational features such as disclosed in United States Patents 5,726,377, 5,760,328, 4,658,702 and 4,433,610, and patent applications Serial No. 60/564,895; 10/836,443 filed respectively on 4/23/04 and 4/30/04, all of which are hereby incorporated by reference herein in their entirety. The firearm 30 and its sections described in greater detail below is merely exemplary, and in alternate embodiments the firearm 30 may have other

sections, portions or systems. Firearm 30 may incorporate a hand guard 40, a receiver section 42, a barrel 24, and stock 44. As will be described further below, hand guard 40 may further incorporate vent holes, ribbing, heat shields or double heat shields and liners to facilitate cooling of the barrel 24 while keeping hand guard 40 at a temperature sufficient for an operator to hold the handguard.

[0054] Firearm 30 has an indirect gas operating system 60 facilitating automatic or semi-automatic operation as will be described below. The indirect gas operating system 60 is adjustable, allowing the operator to vary cyclic rate as desired. The system 60 has a gas block 8 having a cylinder therein. Gas block 8 is fitted to a barrel assembly 24 where barrel 24 has a bore with the cylinder being in fluid communication with the bore through a port. A piston and rod assembly 62 having a piston and a striking rod is housed within hand guard 40 and receiver 42. The piston is fitted to the cylinder. A bolt carriage assembly 64 is provided within receiver 42. The bolt carriage assembly 64 has a striking surface cooperating with the rod of the operating system 60. When a cartridge is fired, pressurized gas enters the cylinder, displaces the piston and causes the striking rod to strike the striking surface displacing the bolt assembly. The cyclic rate selector interfaces with the pressurizing gas in the cylinder to vary the bolt carriage cycle rate during automatic operation of the firearm. Hand guard 40 may have features such as disclosed in United States Patents 4,663,875 and 4,536,982, both of which are hereby incorporated by reference herein in their entirety. Hand guard 40 and

receiver section 42 may be configured to support such rails as a "Piccatiny Rail" configuration as described in Military Standard 1913, which is hereby incorporated by reference herein in its entirety. The rails may be made from any suitable material such as hard coat anodized aluminum as an example. Front sight assembly 48 is shown mounted to rail 50 of hand guard 40. Front sight assembly 48 is removable, allowing alternate mounting of desired accessory in its place such as a telescopic sight or laser sight. In alternate embodiments, front sight 48 may be mounted to barrel 24 as shown in the exemplary embodiment in Fig. 8. Rear sight assembly 52 is provided and mounted to receiver section 42. Rear sight assembly 52 incorporates sight ring 54 and sight adjustment knobs 56 and 58. Sight adjustment knobs 56 and 58 are provided to adjust the position of sight ring 54 relative to the barrel 24 and front sight 48 for accurate target sighting.

[0055] Referring now to Figs. 2 - 3, there is shown respectively a partial top isometric view and a schematic bottom isometric view of the front sight section 48 of the firearm shown in Fig. 1. Referring also to Figs. 4 - 10 there is shown an exploded view of the front sight section 48 and detailed views of the parts included in the assembly of the front sight section of the firearm shown in Fig. 1. Front sight 48 is shown as a detachable or removable front sight within this embodiment mounting to a "Piccatiny" rail though in alternate embodiments the mounting may have any desired configuration. As seen in Fig. 4, the front sight assembly generally comprises base sections 162, front sight post 150, spring loaded pivot assembly 154 and mounting retention members 161A, 161B

(see also Fig. 3). Base 162 includes complementing mounting for the Piccattiny rail to which the front sight assembly 48 in this embodiment is removably mounted. The mounting retention members include clamping bracket or section 161A that is fastened with a locating pin (not shown) to side 162A of the base 162 to clamp the Piccattiny rail. Tightening nut 161B generates clamping pressure to hold the base 162 and bracket 161A on the rail. Base 162 (seen best in Fig. 7) and front sight post 150 (see best in Fig. 6) have complementing features allowing the sight post to be pivotally engaged to the base and shown in Fig. 3. The front sight post 150 is mounted to the base with pin 154 (see Fig. 4). The front sight has a rounded feature 150E that is shaped to coincide with the edges of the hole or ring 152 upon alignment of front and rear sights making it much easier for a user to acquire targets and center the weapon with the combination. The front sight 150 is shown as a raised sight with a folding construction allowing a user to keep the sight in the position shown or rotate the sight to a lowered position. Spring loaded detents lock the sight post 150 in the up or lowered positions. In this embodiment, the pivot pin 154 (see also Figs. 5 and 9B) is provided with a squared head 156 having tapered features 158 that complement angled edges 162E of receiving hole 162B in base 162 (see Fig. 8). The taper facilitates self centering, improved locking and position locking and reduced sight vibration by taper engagement with a mating feature 160 in base 162 aided by a spring load or bias from spring 164. In alternate embodiments, the sight post may have any other suitable spring loaded detents holding the sight post in desired positions. The pivot pin, positioned within mounting bore 150H, is

locked to the sight post 150 by a locking pin (not shown) that mates with slot 166 and hole 168. A thread-on cap feature 170 (see also Fig. 9A) is threaded onto the pin end and retains the spring 164 (see Fig. 5).

[0056] Referring now to Fig. 10, there is shown a side elevation view of the firearm shown in Fig. 1 with the hand guard removed. Referring also to Fig's. 11 and 12, there is shown a partial side elevation view of the firearm shown in Fig. 1 with the hand guard removed. Referring also to Fig. 13, there is shown an exploded view of an automatic firearm incorporating features in accordance with an exemplary embodiment. Referring also to Fig. 14, there is shown a side exploded view of the barrel, receiver, hand guard and gas piston assembly of the firearm shown in Fig. 1.

[0057] Referring also to Fig. 15, there is shown another exploded view of the gas piston assembly and Fig. 15A is an end elevation of the gas block and rate selector in accordance with an exemplary embodiment. As noted before, firearm 30 has an indirect gas operating piston system 60 (see Fig. 10). The indirect gas operating system 60 has a gas block 8 having a cylinder 68 therein. The gas block is schematically shown in perspective in Fig. 16. Gas block 8 is shaped to be mounted to the barrel assembly 24. Barrel 24 has a bore (not shown) for exhausting firing gases. The cylinder 68 in the gas block is in fluid communication with the bore through a port 68P disposed on a surface of the gas block facing the barrel. A piston and rod assembly 62 having a piston 7 and a striking rod 6 (housed within hand guard 40 and receiver 42 when mounted to the firearm) cooperate with the gas block 8. The piston 7 (see Fig. 20) is movably

fitted to the cylinder 68. The striking rod 6 (see also Fig. 19) is fixedly joined at its front end, for example by a threaded connection, to the piston 7. In this embodiment, piston 7 has a bore 74 that accepts the tip 76 of rod 6. Piston 7 has a shoulder 78 that mates with flange 80 of rod 6. In alternate embodiments, other engagement techniques could be provided. Gas block 8 is fitted onto barrel 24. Thus, gas block 8 has a cylinder 68 that houses piston 7 with the piston 7 engaging rod 6 that extends back to engage bolt assembly 64. The bolt carriage assembly 64 is provided within receiver 42 (see Fig. 13) with the bolt assembly carriage 64 having a striking or engagement surface that is engaged by the rear end of the operating rod as will be described below. When a cartridge is fired, pressurized gas from the barrel enters the cylinder, displaces the piston and causes the engaging rod 6 to strike a striking surface on the bolt carriage assembly displacing the bolt assembly. Guide 4 (see Fig. 5) houses operating rod 6 allowing operating rod 6 to slide freely relative to the receiver. Guide 4 also has a feature 108 that mates with mating feature 110 (see Figs. 14, 15) of receiver 42 to correctly position rod 6 relative to the bolt carriage assembly within receiver 42. Spring 5 is provided between shoulder 72 of rod 6 and guide 4 to bias the rod toward the gas block.

[0058] The indirect gas operating system 60 in this embodiment has valving or pressure regulator to allow the user to select desired operating pressure and hence to select the cyclic rate. In this case, the regulator is incorporated into the gas block, and adjustment is provided by a rotating knob 10 (a perspective view of which is shown in

Fig. 17). The gas pressure that is exerted on the piston may be varied by the user by loosening fastener 11 (see Fig. 13) and rotating knob 10. By rotating knob 10 to selectable positions, different charges or rates are applied to the piston by variable gas pressure and selectable force. The knob 10, in the embodiment shown in Figs. 17-18, generally covers the end 82 of gas block 8 opposing the piston (see also Fig. 15). In particular, knob 10 covers or interfaces with a portion of the cylinder 68 that has an exhaust port 84. In alternate embodiments, the knob could have a different shape or be in a different position. The cylinder 68 (see Fig. 16) has one or more exhaust orifices or ports 84 formed in the front end 82 of the gas block. In the embodiment shown the port 84 (one is shown, but any suitable number may be provided) is offset from the center of the cylinder 68 or the knob. In this embodiment, the port 84 is located in a region generally between the cylinder 68 and barrel 24, and away from the top most portion of the gas block. This allows the gas block profile (i.e. the height above the barrel) to be minimized so that the gas block may be accommodated within the hand guard, and the size of the exhaust port is not impacted. In this embodiment port 84 has an inlet 84I in the end face 68E of the cylinder 68 opposing the piston I. In alternate embodiments, the port inlet may be located on any other desired surface of the cylinder. Blind hole 86 may also be provided to locate features 88, 90 of knob 10 correctly. The end of the gas block may also have a threaded hole for fastener 11, though in alternate embodiments the gas block may have an integral fastening post onto which the knob 10 is threaded. The knob also has one or more bosses complementing port 84 and having

exhaust orifices or ports 92, 94 with different bore sizes or diameters in the embodiment shown offset from the center of the cylinder or the knob. The holes 92, 94 are sized for each to allow a different desired exhaust flow such as may be used with different particular charges. One boss position may be blind or has no hole or is completely blocked. In alternate embodiments the knob may have any desired number of selectable positions. This allows the user to have increased flexibility as to the ammunition or charge used. Thus, by rotating the knob, the effective size of the port or orifice exiting the cylinder to ambient air may be increased, decreased or eliminated allowing gas to either blow through the orifice at a variable rate, thus controlling the amount and pressure of gas applied to the piston. In alternate embodiments more or less holes or orifices may be provided. In the embodiment shown, exhaust gasses are directed toward the muzzle of the firearm, away from the operator; in alternate embodiments, other directions or locations could be provided. In the embodiment shown, the gas block 8 and the piston 7 and rod assembly 6 fits within the hand guard assembly in a low profile relative to other block systems. The embodiment shown may employ a short barrel 24 with a shorter operating rod that results in higher impact loads to the bolt assembly.

[0059] Referring also to Figs. 21 and 22, there are shown partial elevation views of a firearm 30 with an indirect gas operating piston system 60' in accordance with another exemplary embodiment. Referring also to Fig. 28, there is shown a section view of the gas piston assembly 60'. As noted before, firearm 30 is illustrated in the figures as having a general M4 type configuration for

example purposes, but may be any suitable type of automatic or semi-automatic firearm having an indirect gas operating system 60'. As noted before, firearm 30 may have a bolt carriage assembly 64 having a striking surface 126 (see Fig. 32), where the bolt assembly is enclosed within the receiver assembly 42 (see also Fig. 13) where barrel assembly 24 may be coupled to the receiver assembly 42. Though Fig. 1 shows an M4 type firearm, it is noted that the gas piston assembly 60', in accordance with the exemplary embodiment described herein, may be used with any type of automatic or semi-automatic firearm having an indirect gas operating system operating the bolt assembly. Except as otherwise noted, indirect gas operating system 60' is similar to gas operating system 60 described before. Similar features are similarly numbered. Gas block 202 having cylinder 206 may be fitted to barrel assembly 24, with the cylinder 206 in communication with the bore 208. Piston and rod assembly 62' having a piston 7' and an engaging rod 6', have piston 7' fitted to cylinder 206. Gas discharged from a fired cartridge displaces piston 7' and causes engaging rod 6 to strike striking surface 126 displacing bolt assembly 64. Exhaust port 218 may be in communication with cylinder 206 and piston 7 whereby gas is exhausted when piston 7' reaches for example an end stroke position opening exhaust outlet 224 in the cylinder 206. In alternate embodiments, other exhaust ports may be provided or selectable between positions. The cylinder 206, and piston 7' therein are in communication with barrel bore 203 via passages 240, 242 and an intermediate throttle or regulator 214 having selectable positions 230, 232 (see Fig. 21, 22) corresponding to selectable firing rates. In this

embodiment, the regulator 214 is shown as having two selectable positions 230, 232 corresponding to two selectable firing rates. In alternate embodiments, more or less selectable positions, corresponding to more or fewer selectable firing rates may be provided. Intermediate regulator 214 may be switched between the two selectable positions 230, 232 by an operator without the use of specific tools (e.g. screwdriver, wrench, dedicated key) where the operator simply rotates an arm of the selector 214 as shown in positions 230, 232. As described before, piston 7' may be spring biased toward cylinder 206 and piston 7' and striking rod 6' may be separable (e.g. The striking rod 6' is fixedly joined at its front end, for example by a threaded connection, to the piston 7'. In this embodiment, piston 7' has a bore 74' that accepts the tip 76' of rod 6'. Piston 7' has a shoulder 78' that mates with flange 80' of rod 6'. In alternate embodiments, other engagement techniques could be provided. In alternate embodiments, piston 7' and rod 6' may be monolithic. The piston assembly may have a piston end 220, and a striking end 236 (see Fig. 13), where the piston end may be fitted to cylinder 206. Here, gas discharged from a fired cartridge displaces piston 7' and causes striking end to strike and displace bolt assembly 64. The intermediate regulator 214 throttles or regulates the flow of the pressurized gas from the barrel bore 208 to the cylinder 206. As noted before, intermediate regulator 214 may have two selectable positions 230, 232 corresponding to two selectable firing rates, such as, for example 800 and 1000 rounds per minute. In alternate embodiments, other factors, such as load type and size may be selectable between the two selectable positions 230, 232 by an operator without the

use of tools. In the exemplary embodiment, the intermediate regulator 214 may have throttling orifices 228, 226 positioned in communication passages 240, 242 as shown for example in Fig. 28. In alternate embodiments any desired number of throttling orifices may be used and may have any desired shape. The cylinder 206 in communication with the bore 208 via the first orifice 228 when intermediate regulator 214 is in a first selectable position 230. The cylinder 206 is in communication with bore 208 via second orifice 226, when intermediate regulator 214 is in a second selectable position 232. Here, the first and second selectable positions 230, 232 correspond to first and second firing rates where the first and second orifices 226, 228 are of different size. Such size may be determined by orifice effective flow diameter, or other suitable feature. In the embodiment shown, intermediate regulator 214 is rotationally housed within block 202. In the section shown in Fig. 28, intermediate regulator 214 has orifices 226, 228 positioned to connect passages 240, in communication with bore 208 in barrel 24 and passage 242 in communication with the cylinder 206. In Fig. 28, regulator passages 216 connects passages 240, 242 throttling flow from barrel 24 to cylinder 206 corresponding to one selectable cyclic rate. As may be realized, when the regulator 214 is rotated so that regulator passage 228 connects passages 240, 242, flow between barrel and cylinder is throttled corresponding to another selectable cyclic rate. The embodiment shown may be provided with any suitable combination of features, such as where bolt assembly 64 may have a removable striking surface 126 (see Figs. 33, 34). Here, cylinder 206 may be fitted to the barrel assembly 24 with cylinder 206 in communication with bore

208 via intermediate regulator 214 having two selectable positions 230, 232 corresponding to two selectable firing rates. As described before, gas discharged from a fired cartridge displaces piston 7' and causes the striking end of the engaging rod 6 to displace bolt assembly 64 where intermediate regulator 214 regulates the flow of the gas from the bore 208 to the piston 7'.

[0060] As described above, indirect gas operating system 60' has a gas block 202 having a cylinder 206 therein. Referring also to Figs. 23 and 24, the gas block is shown in perspective. Gas block 202 is shaped to be mounted to the barrel assembly 24. Gas block 202 has a retaining clip or pin 280 provided to retain selector 214. Retaining clip 280 may be removed from block 202 to remove selector 214. Gas block 202 has recess 282 provided to accept selector 214. Recess 282 has portion 284 sized to house retaining and locating features 292 of selector 214. Gas block 202 further has detent pin 286 provided to locate and hold selector 214 in a selectable position. Gas block 202 further has bore 288 provided therein for locating and fastening to barrel 24 with suitable fasteners and fastening features. Referring also to Figs. 25 - 27, intermediate regulator or selector 214 is shown. As noted before, selector 214 is rotatably mounted in block 202 where retaining feature 292 comprising, for example, a recess that cooperates with clip 280 whereby selector 214 is retained in housing 202 when clip 280 is in place. Selector 214 has orifices 226, 228 that may be of different size. In the embodiment shown, orifices 226, 228 are intersecting; in alternate embodiments, orifices 226, 228 may not be intersecting. In alternate embodiments, more or fewer orifices may be provided.

Selector 214 has shaft 290 which engages in corresponding bore 282 of block 202 whereby gas is directed through ports in the selected orifice. Detent features 294, 296 are provided in selector 214 and cooperate with a spring loaded member, such as flexure 286, of block 202 to hold the selector in the desired position. Referring also to Fig. 28, barrel 24 has a bore 208, an exhaust port 212 disposed to communicate with the passage 240 in the gas block facing the barrel. Gas block 202 is fitted onto barrel 24 by appropriate fastening methods. Thus, gas block 202 has a cylinder 206 that houses piston 7' with the piston 7' engaging rod 6' that extends back to engage bolt assembly 64. The bolt carriage assembly 64 is provided within receiver 42 with the bolt assembly 64 having a striking or engagement surface that is engaged by the rear end of the operating rod. When a cartridge is fired, pressurized gas enters cylinder 206, displaces piston 7' and causes the striking rod 6' to strike the striking surface displacing the bolt assembly. A spring, similar to spring 5 in Fig. 13, is provided between shoulder 72' of rod 6' and guide 4 to bias rod 6' toward cylinder 202. Referring again to Figs. 25 - 27, the user may select a desired cyclic rate with selector 214. Here, selector 214, which as noted before is rotatably mounted within block 202, is rotated to select the desired rate. The amount of gas flow and / or pressure that is exerted on the piston may be varied by the user when rotating selector 214. By rotating selector 214 to selectable positions, different charges or rates are applied to the piston by variable gas pressure, flow and selectable force. Exhaust port 218 may vent gas upon sufficient motion of piston 7', such as where front 220 of piston 7' passes port 224 of block 202 in

communication with vent 218. In alternate embodiments, the selector could have a different shape or be in a different position. Throttling orifices 226, 228 in the selector may be sized for each to allow a different desired flow such as may be used with different particular charges or with different desired firing rates. This allows the user to have increased flexibility as to the firing rate, ammunition or charge used. Thus, by rotating the selector, the effective size of the port or orifice between bore 208 and cylinder 206 increased, decreased or eliminated allowing gas to blow through the orifice at a selectable variable rate, and throttling the amount and pressure or flow of gas applied to the piston. In alternate embodiments more or less holes or orifices may be provided. In the embodiment shown, exhaust gasses 218 are directed toward the muzzle of the firearm, away from the operator; in alternate embodiments, other directions or locations could be provided. In the embodiment shown, the gas block 202 and the piston 7' and rod assembly 6' fits within the hand guard assembly in a low profile relative to other block systems. The embodiment shown may employ a short barrel 24 with a shorter operating rod that results in higher impact loads to the bolt assembly.

[0061] Referring also to Fig. 29, there is shown a front cross section of a gas block section of an indirect gas operating system 60'' in accordance with yet another embodiment. The gas block 252 in this embodiment has intermediate regulator 258 that slides rectilinearly within the gas block. In the embodiment shown, intermediate regulator 258 may be slidably selectable between two selectable positions 260, 262 corresponding

to two different firing rates. When the intermediate regulator 258 is in first position 260, bore 208 is in communication with cylinder 254 and piston end 220 via passages 264, 266, throttling orifice 270 and passage 272. When the intermediate regulator 258 is in second position 262, bore 208 is in communication with cylinder 254 and piston end 220 via passages 264, 266 throttling orifice 268 and passage 272. Spring loaded detents 256 may be provided to allow intermediate regulator 258 to be retained in position 260 or 262 where a user may simply snap the regulator into either position by pushing on the opposing end. In this manner, the firing rate may be changed without the use of tools in the field. Exhaust vent 276 may be provided to vent gas' when the piston extends to a predetermined location. In alternate embodiments, more or less positions or orifices may be provided, for example a third or fourth position where a different orifice size or no orifice is present.

[0062] Referring now to Fig. 32A, there is shown a view of a bolt carriage assembly 64 of the firearm shown in Fig. 1 in accordance with an exemplary embodiment. Referring also to Figs. 33 - 34, there is shown an exploded view of a bolt assembly of the firearm shown in Fig. 1. The embodiment shown may employ a short barrel 24 with a shorter operating rod 6 that results in higher impact loads to the bolt carriage assembly. As a result, the bolt carriage assembly 64 is subjected to such higher impact and operating loads. In Fig. 32B, the assembly is a conventional (M4) direct gas operated bolt carriage assembly. Bolt carriage assembly 64 has a bolt carriage frame or carrier 120, a strike portion or key assembly

122 and a stop member 124. Strike portion 122 is struck by rod 6 (or rod 6') at face or portion 126. As seen in Fig. 13 strike face 126 is located to be substantially coaxial with the operating rod 6. The strike portion 126 is suitably shaped (e.g. tapered) to direct loads imparted by rod 6 into the base 122B that engages the strike portion 122 to the carrier frame. Strike portion 122 has a keyed portion 128 on base 122B that engages corresponding keyed lateral grooves 120G in frame 120 that form a generally T-shaped keyway. Additionally a front notch engagement portion 130 may be provided in the base 122B of strike portion 122 to engage a corresponding front key groove 120GF in carrier 120. The keys 128 on the base of the strike portion 122 are sized to form a press or force fit with the keyways 120B, 120GF of the carrier frame. Upon pressing strike portion 122 into its corresponding grooves of carrier 120, stop piece 124 is fastened to carrier 120 using fastener 134 to further retain strike portion 122. Stop piece 124 has a lock step engaging the end of the strike 122. In alternate embodiments, the key ways could be provided within the strike portion and a corresponding interface on the carrier. In this manner, the bolt assembly 64 may withstand higher impact and operating loads.

[0063] Referring now to Fig. 35, there is shown a side elevation view of a hand guard assembly 40 of the firearm shown in Fig. 1. Referring also to Fig. 36, there is shown a top elevation view of a hand guard assembly 40 of the firearm shown in Fig. 1. Referring also to Fig. 37, there is shown a side elevation view of a hand guard assembly 40 of the firearm shown in Fig. 1. Referring also to Fig. 38, there is shown a side elevation view of a hand guard

1 and removed relocatable rails of the firearm shown in Fig. 1. Referring also to Fig. 39, there is shown an isometric view of a front end of hand guard 1 of the firearm shown in Fig. 1. Hand guard 40 has an aluminum shell 1 that in this embodiment is of unitary construction and has vent holes and external ribbing. Hand guard 40 is ergonomically sized to allow a user to comfortably grip the guard. Shell 1 is mounted to the receiver 42 and is floating relative to barrel 24 and barrel radiator 102. In alternate embodiments, multiple shells, inner ribbing, heat shields or double heat shields and liners to facilitate cooling of the barrel 14 while keeping hand guard 40 at a temperature sufficiently low for an operator could be provided. Removable and relocatable rails 2, 136 may be provided on hand guard 40 and may be permanently mounted or removably mounted and be removable or moveable to different locations on hand guard 40. The rails and mounting system to the hand guard may be substantially similar to rails described in U.S. Patent application Serial No. 11/113,525 filed 4/25/05, which is incorporated by reference herein in its entirety. In alternate embodiments, rails 2, 136 may be in different locations with different sizes. In this embodiment, the guard mount to the receiver has an upper lug 138 that is provided to interface and mount to a corresponding slot 140 in the frame of the upper rail of upper receiver 42 (see Fig. 31). Removable bottom lug 26 is provided to engage a corresponding slot or clevis 142 (see Fig. 30) machined into the standard front bottom lug attachment of the lower and upper receiver 42. In this manner, the rear of guard 1 has a lug 26 recessed into the bottom clevis 142. In this manner, guard 1, via lug 26 is locked to lower receiver 144 and upper receiver 42

with the same pin 146 (see Fig. 13) and guard 1 is further locked to upper receiver via lug 138 and pin 27 (see Fig. 13)..

[0064] Referring now to Fig. 30A, there is shown a bottom view of a receiver assembly 42 of the firearm shown in Fig. 1. Referring also to Fig. 31A, there is shown a top view of a receiver 42 of the firearm shown in Fig. 1. In Fig. 30B, 31B are respective bottom and top views of a conventional M4 receiver as shown for example purposes. As shown in Fig. 31A, slot 140 in the frame of the upper rail of upper receiver 42 is provided to interface and mount corresponding lug 138 of hand guard 1. As shown in Fig. 30A, slot or clevis 142 is machined into the front bottom lug, that forms the attachment of the lower and upper receivers, to engage the corresponding removable lower lug 26 of hand guard 40. Hence, the rear of guard 1 has a lug 26 recessed into the bottom clevis 142. Thus as shown in Fig. 1 and as may be realized from Fig. 13, when mounted, guard 1 is locked via lug 26 to lower receiver 144 and upper receiver 42 with the pin 146 connecting the lower and upper receivers to each other and guard 1 is further locked to upper receiver via lug 138 and pin 27 (see Fig. 8). As seen in Fig. 1, and as noted before, when mounted, the hand guard 1 covers the indirect gas operating system 60. The gas block 8 (or gas block 202, 252) is housed inside the guard 1. This is facilitated by the low profile of the gas block. As seen in Fig. 39, the guard may include an inner groove 1G or channel in which the gas operating system 60 is disposed. The channel provides sufficient clearance around the gas operating system 60 for unencumbered operation. Claim 1G

may have a flared or widened portion 1M in way of the gas block.

[0065] Firearm 30 may have a forced air cooling system as will be described in accordance with another exemplary embodiment. As seen in Fig. 40, radial air grooves 100 are provided on barrel 24 that extend into the receiver section. The air grooves 100 are part of the forced air cooling system that utilizes the motion of the bolt and bolt carriage assembly to pump cool air along the barrel and through hand guard assembly (e.g. guard 1) which houses a radiator element 102 that surrounds a reduced diameter portion of the barrel 24. Air is forced from the receiver by the bolt assembly, through the barrel retaining nut 106 via grooves 100 into and around the radiator and out cooling holes or slots in the hand guard. In alternate embodiments, the cooling system may be employed on alternate firearm types.

[0066] Referring still to Fig. 40, there is shown an elevation view of a barrel and radiator assembly of the firearm shown in Fig. 1. Referring also to Fig. 41, there is shown an elevation view of a barrel and radiator assembly where the radiator 102 is removed from the barrel 24 of the firearm shown in Fig. 1. As noted before, air grooves 100 are provided on the flared outer portion of barrel 24 that extend into the air flow within the receiver section. When mounted to the receiver 42, the grooves 100 form channels between the surface of the barrel nut 23 (mounting the barrel to the receiver) and barrel (see also Fig. 10). As seen in Fig. 40, grooves 100 extend through barrel retention flange 24F. The air flow channels on the barrel are aligned to direct flow towards and over the radiator 102 on the barrel 20. In this

embodiment, radiator 102 is an assembly of two substantially similar parts. Each portion has a generally semicircular cross-section with an inner diameter sized to provide desired thermal conductive contact with the undercut section 104 of the barrel. The radiator is made of aluminum or any other desired material with good heat conduction properties. The outer surface of each radiator section has suitable radiator fins formed therein. In this embodiment, the radiator fins are longitudinally aligned. As may be realized from Fig. 10, air is forced from the receiver by the bolt assembly, through the grooves in the barrel, and directed over the fins of radiator 102. Cooling holes or slots in the hand guard further aid convection cooling. In alternate embodiments, the cooling system may be employed on alternate firearm types. Portions of radiator 102 may be fastened together, by screws as an example. Radiator 102 may have fins or multiple panels or surfaces. In alternate embodiments, the size, shape or number of fins of radiator 102 may be varied. In this embodiment a Bottom shield 112 (see Fig. 10) may be removably mounted to radiator 102 to protect the hand of the user grasping the guard. The shield may be of any desired size and shape. The shield may be made of sheet metal curved to conform generally to the inside of guard 1. Radiator 102 may be keyed or otherwise fastened to barrel 24 to maintain orientation of the shield 112 or radiator 102. As seen in Fig. 10 heat shield 112, in this embodiment may be is fastened to the lower portion of the radiator to shield the operator's hand, on the hand guard from heat dissipated from the barrel and radiator. The shield may be suitably fastened to the radiator and is located to provide an air gap with the radiator element.

[0067] It should be understood that the foregoing description is only illustrative of the invention. Various alternatives and modifications can be devised by those skilled in the art without departing from the invention. Accordingly, the present invention is intended to embrace all such alternatives, modifications and variances which fall within the scope of the appended claims.

CLAIMS

1. An M4 type automatic or semi-automatic firearm having an indirect gas operating system comprising:

a bolt assembly having a striking surface, the bolt assembly enclosed within an M4 type receiver assembly;

a barrel assembly having a bore, the barrel assembly coupled to the receiver assembly;

a gas block having a cylinder, the gas block fitted to the barrel assembly, the cylinder in communication with the bore; and

a piston and rod assembly having a piston and a striking rod, the piston fitted to the cylinder;

wherein, gas discharged from a fired cartridge displaces the piston and causes the striking rod to strike the striking surface displacing the bolt assembly.

2. The M4 type automatic or semi-automatic firearm of claim 1 further comprising an exhaust port in communication with the bore and the piston.

3. The M4 type automatic or semi-automatic firearm of claim 2, wherein the exhaust port is selectable between two positions corresponding to two firing rates.

4. The M4 type automatic or semi-automatic firearm of claim 1, wherein the piston and the bore are in

communication via an intermediate regulator having two selectable positions corresponding to two selectable firing rates.

5. The M4 type automatic or semi-automatic firearm of claim 4, wherein the intermediate regulator may be switched between the two selectable positions by an operator without the use of tools.

6. The M4 type automatic or semi-automatic firearm of claim 1, wherein the piston is spring biased toward the cylinder.

7. The M4 type automatic or semi-automatic firearm of claim 1, wherein the piston and the striking rod are separable.

8. An automatic or semi-automatic firearm having an indirect gas operating system comprising:

a bolt assembly enclosed within a receiver;

a barrel assembly having a bore and coupled to the receiver;

a cylinder fitted to barrel assembly, the cylinder in communication with the bore via an intermediate regulator; and

a piston assembly having a piston end and a striking end, the piston end fitted to the cylinder;

wherein, gas discharged from a fired cartridge displaces the piston and causes the striking end to displace the bolt assembly, and wherein the intermediate regulator regulates the flow of the gas from the bore to the piston.

9. The automatic or semi-automatic firearm of claim 8, wherein the intermediate regulator has two selectable positions corresponding to two selectable firing rates.

10. The automatic or semi-automatic firearm of claim 9, wherein the intermediate regulator may be switched between the two selectable positions by an operator without the use of tools.

11. The automatic or semi-automatic firearm of claim 8, wherein the intermediate regulator has a first orifice with the cylinder in communication with the bore via the first orifice when the intermediate regulator is in a first selectable position, and wherein the intermediate regulator has a second orifice with the cylinder in communication with the bore via the second orifice when the intermediate regulator is in a second selectable position, and wherein the first and second selectable positions correspond to first and second firing rates, and wherein the first and second orifices are of different size.

12. The automatic or semi-automatic firearm of claim 8, wherein the cylinder is housed within a block, and wherein the block is mounted to the barrel, and wherein the intermediate regulator is rotationally housed within the block.

13. The automatic or semi-automatic firearm of claim 12, wherein the intermediate regulator has an orifice, and wherein the block has a first port in communication with the barrel and the orifice, and wherein the block has a second port in communication with the orifice and the cylinder.

14. The automatic or semi-automatic firearm of claim 8, wherein the bolt assembly has a removable striking surface, and wherein the piston assembly comprises a separable piston and striking rod, and wherein the piston is spring loaded into the cylinder via a spring force exerted by the striking rod.

15. An automatic or semi-automatic firearm having an indirect gas operating system comprising:

a bolt assembly enclosed within a receiver;

a barrel assembly having a bore and coupled to the receiver;

a cylinder fitted to the barrel assembly, the cylinder in communication with the bore via an intermediate regulator;

a piston assembly having a piston end and a striking end, the piston end fitted to the cylinder; and

the intermediate regulator having two selectable positions corresponding to two selectable firing rates;

wherein, gas discharged from a fired cartridge displaces the piston and causes the striking end to displace the bolt assembly, and wherein the intermediate regulator regulates the flow of the gas from the bore to the piston, and wherein the intermediate regulator may be switched between the two selectable positions by an operator without the use of tools.

16. The automatic or semi-automatic firearm of claim 15, wherein the intermediate regulator is rotationally selectable between the two selectable positions.

17. The automatic or semi-automatic firearm of claim 15, wherein the intermediate regulator is slidably selectable between the two selectable positions.

18. The automatic or semi-automatic firearm of claim 15, wherein the piston assembly is spring loaded toward the cylinder.

19. The automatic or semi-automatic firearm of claim 15, wherein the barrel assembly has a port in communication with the bore and an orifice of the intermediate regulator, and wherein the orifice is in communication with the cylinder.

20. The automatic or semi-automatic firearm of claim 15, wherein the cylinder is housed within a block, and wherein the block is mounted to the barrel, and wherein the intermediate regulator is rotationally housed within the block, and wherein the intermediate regulator has an orifice, and wherein the block has a first port in communication with the barrel and the orifice, and

wherein the block has a second port in communication with the orifice and the cylinder, and wherein the bolt assembly has a removable striking surface, and wherein the piston assembly comprises a separable piston and striking rod, and wherein the piston is spring loaded into the cylinder via a spring force exerted by the striking rod.

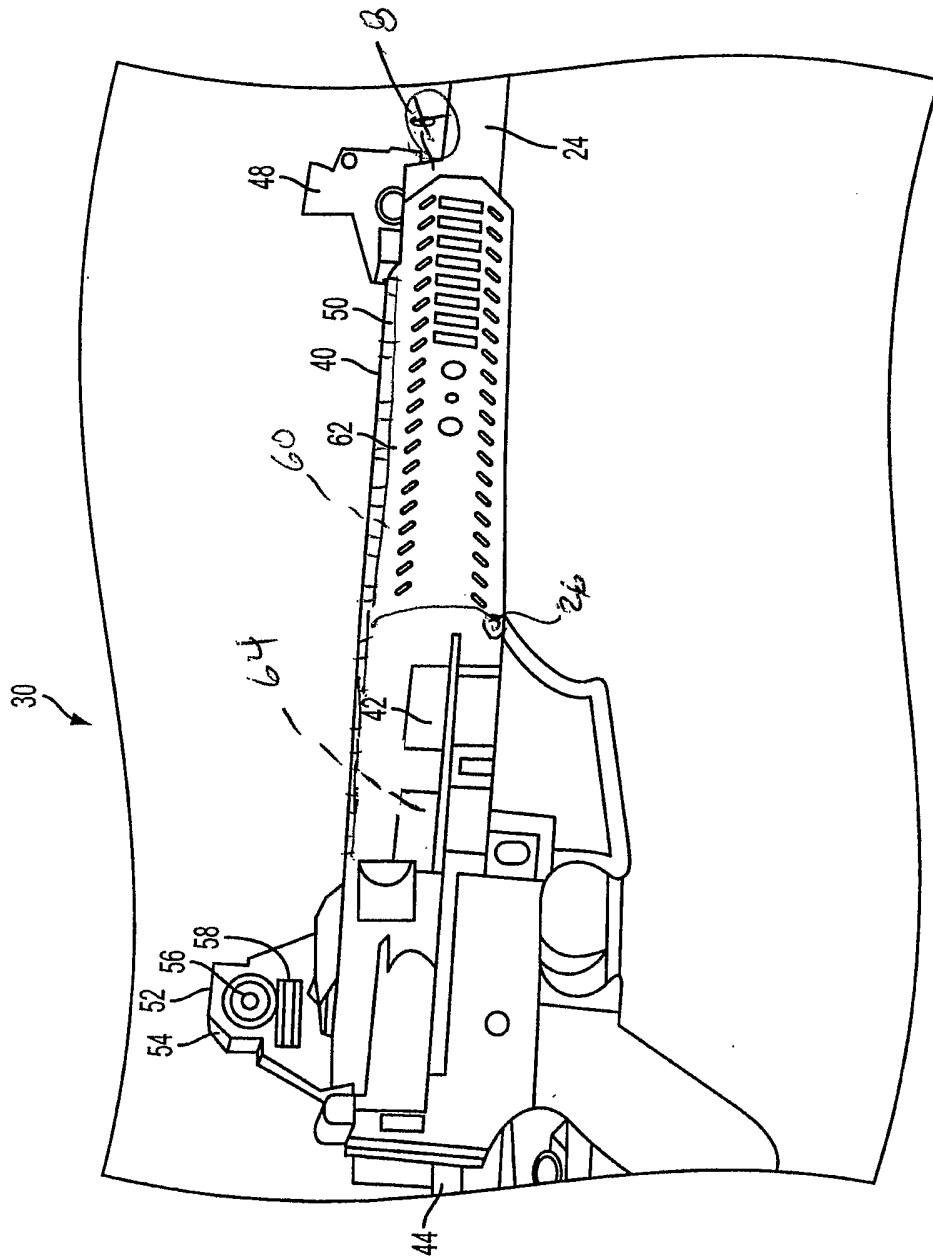

FIG. 1

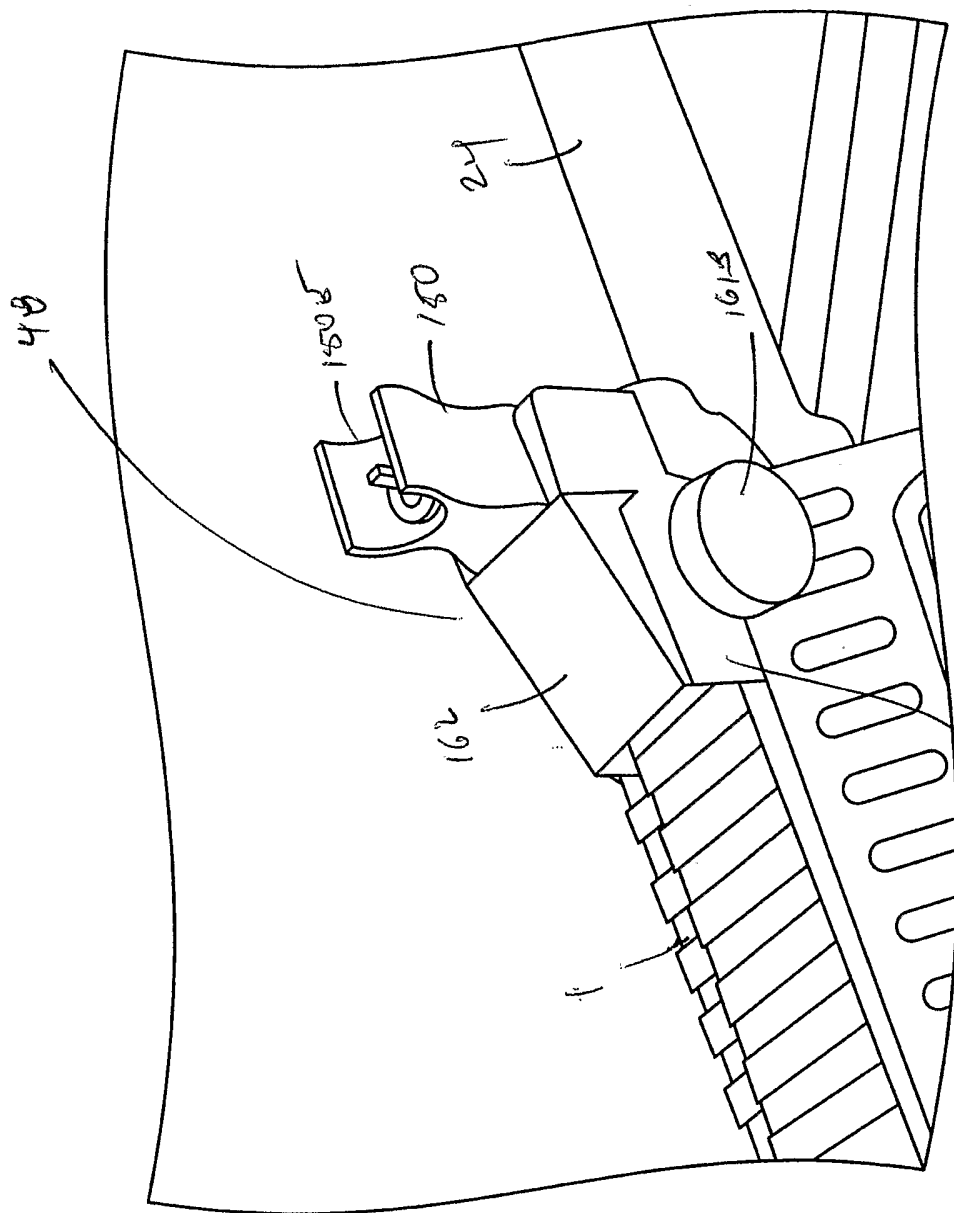

FIG. 2

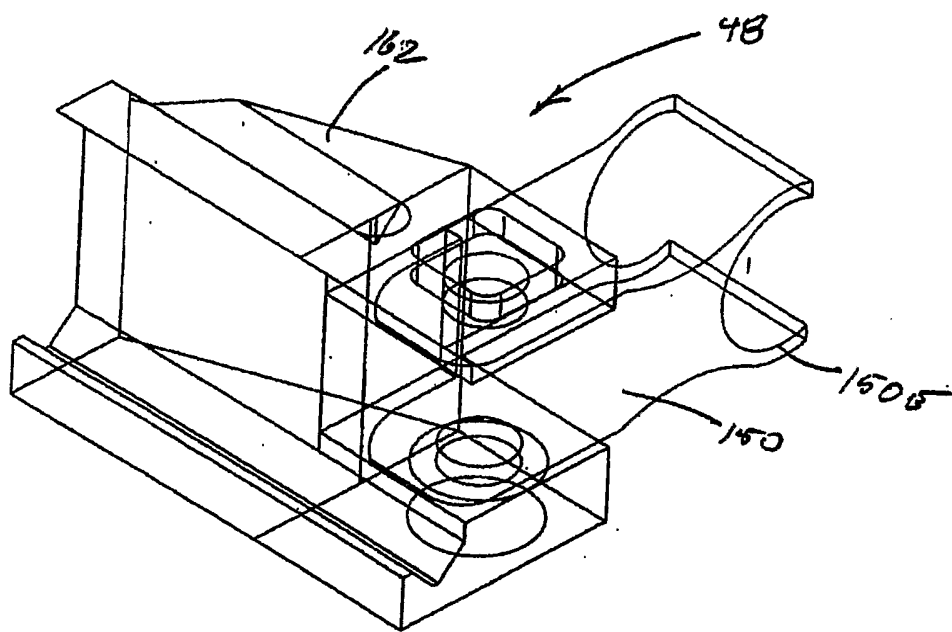
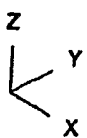

FIG. 3



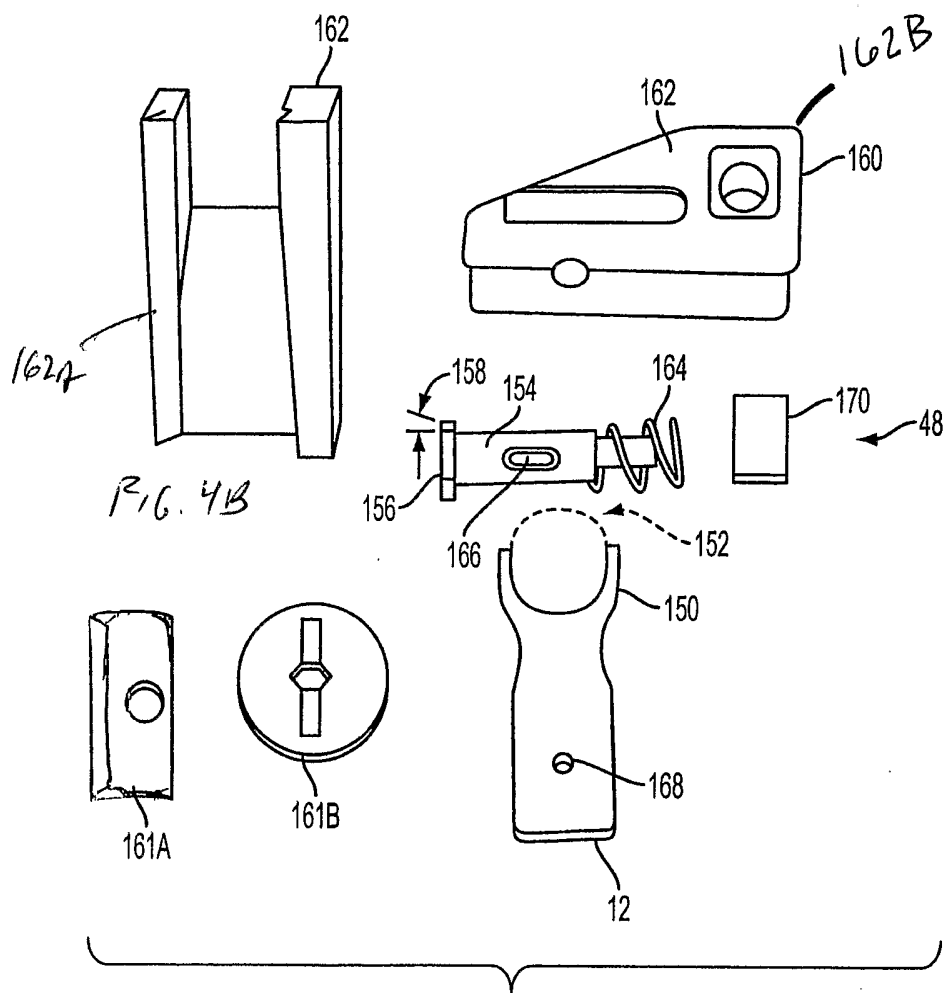

FIG. 3/4A

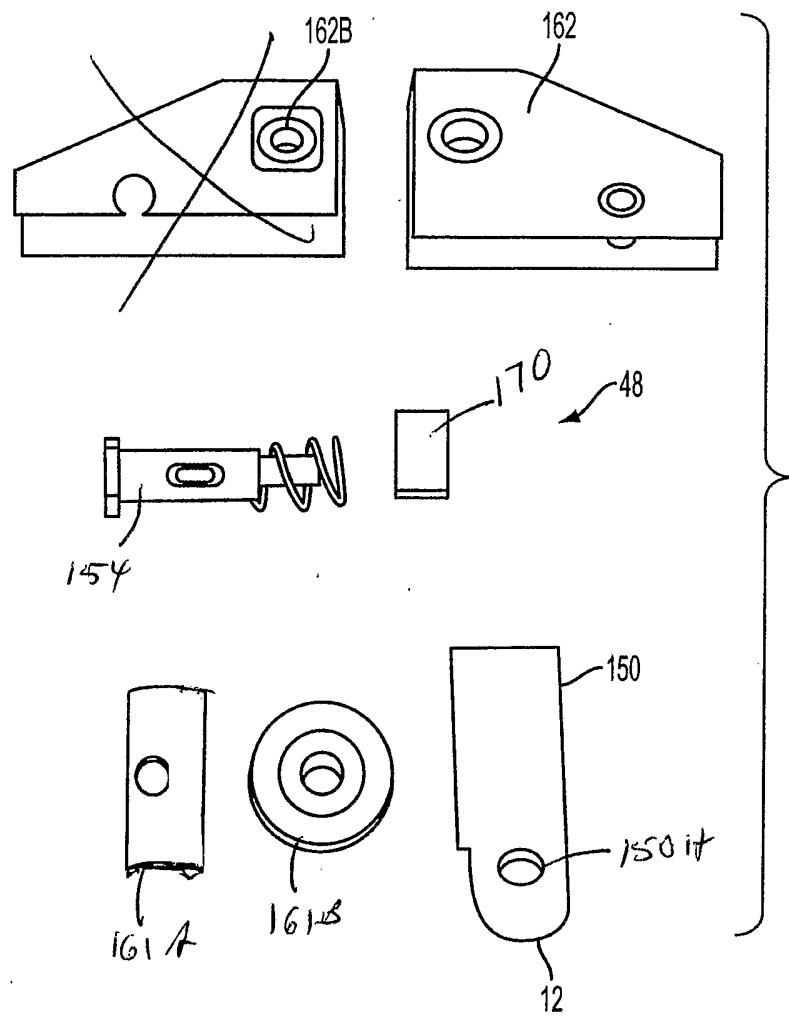

FIG. 4 ~~5~~

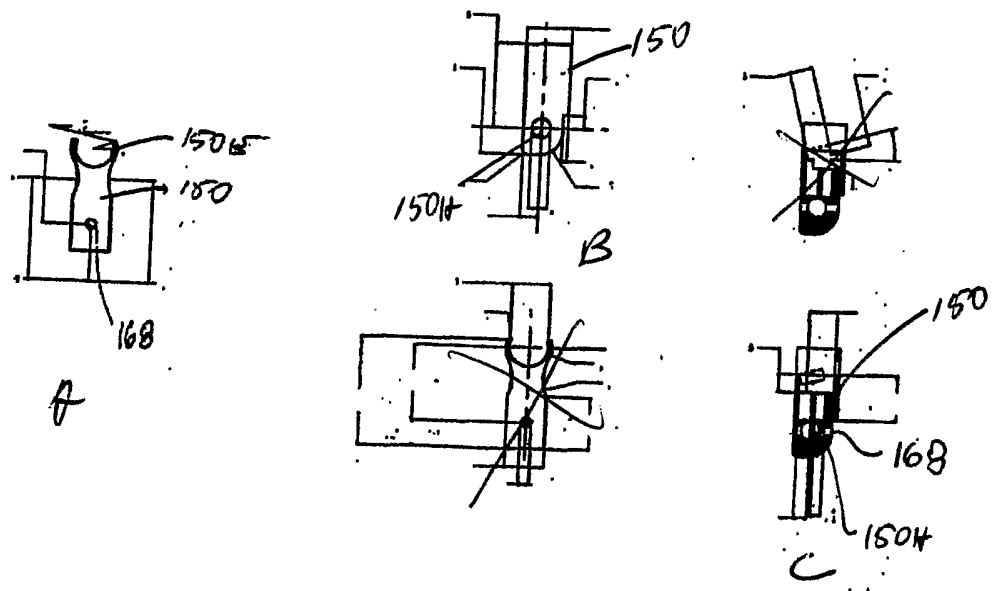
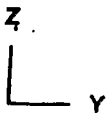

FIG. 6



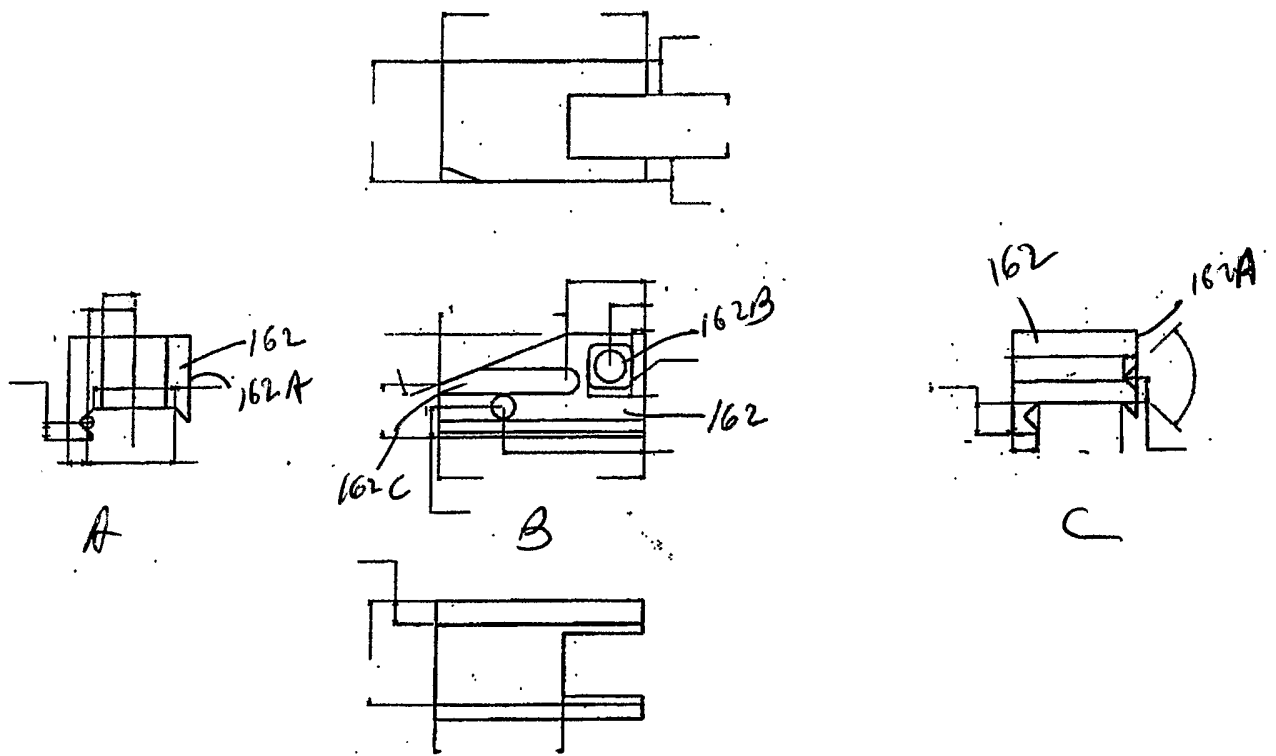
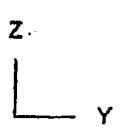

FIG. 7



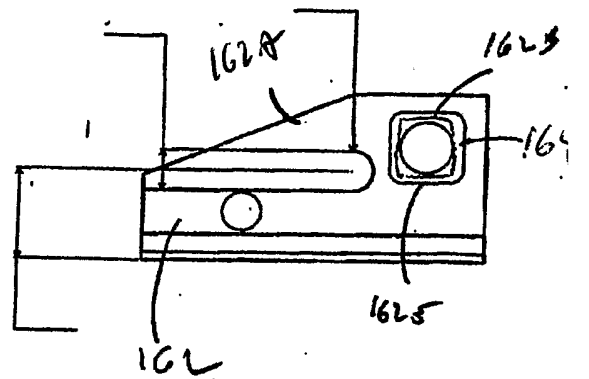
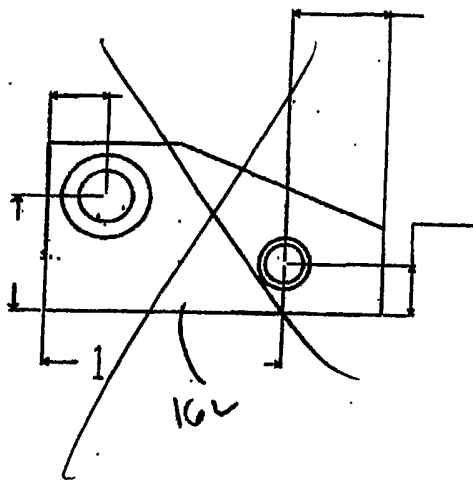
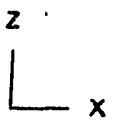

FIG. 8



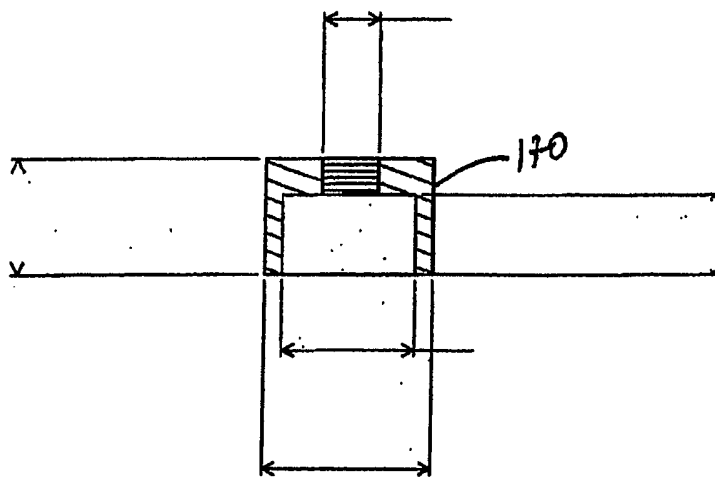
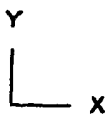

FIG. 9A



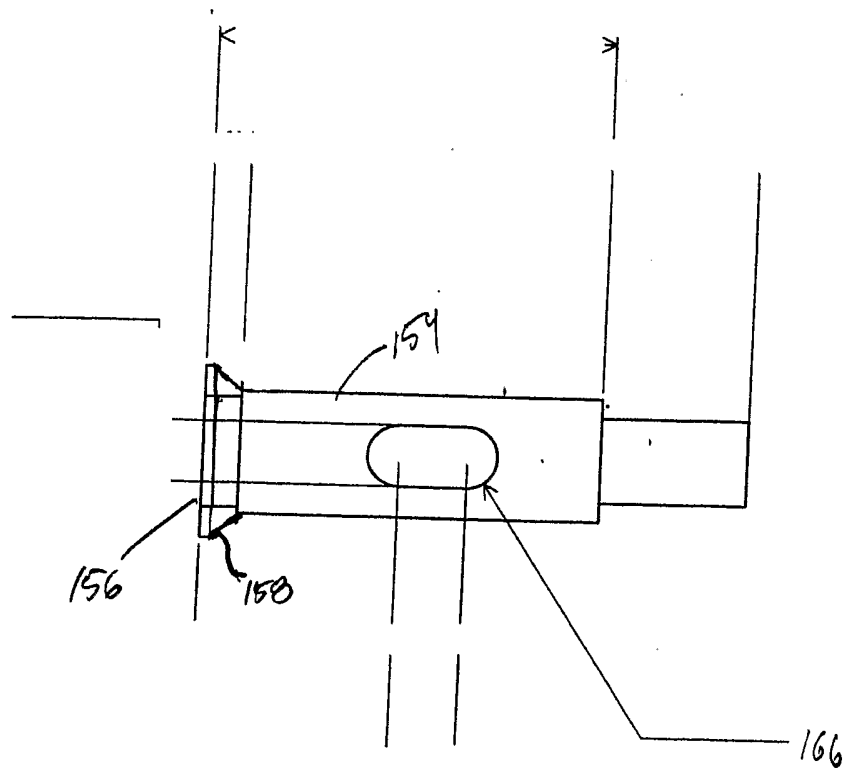
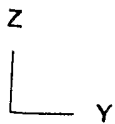

FIG. 9B



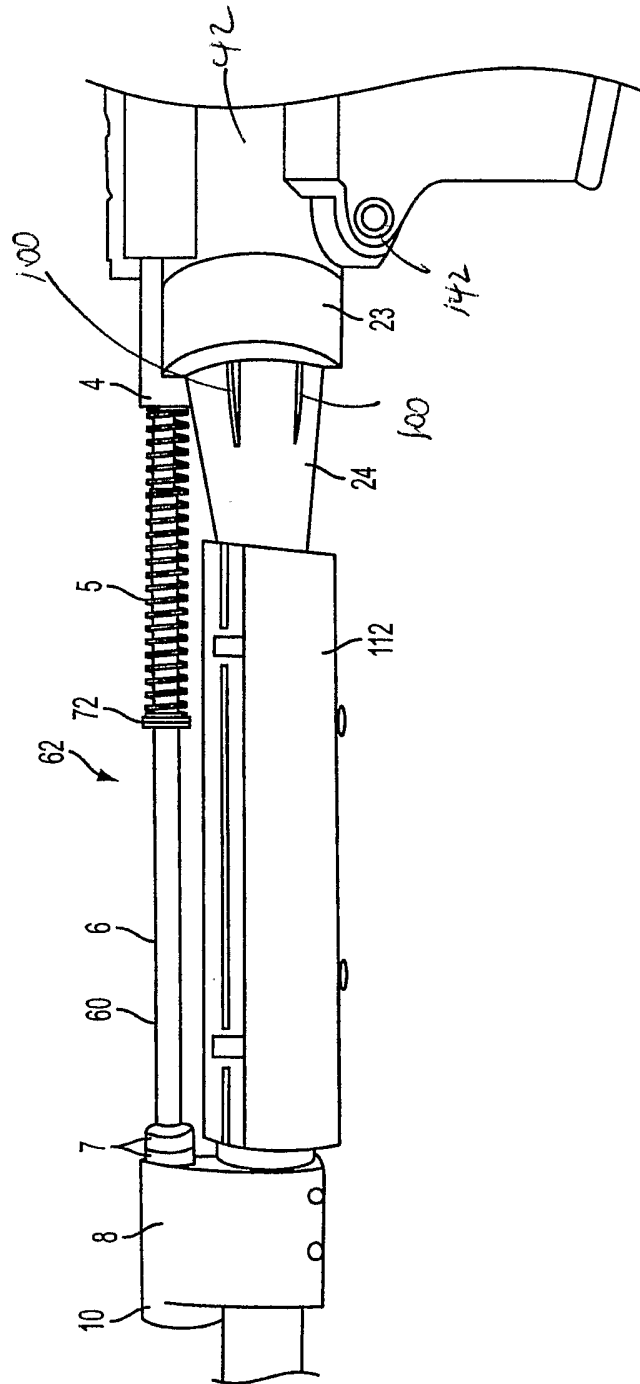

FIG. 10

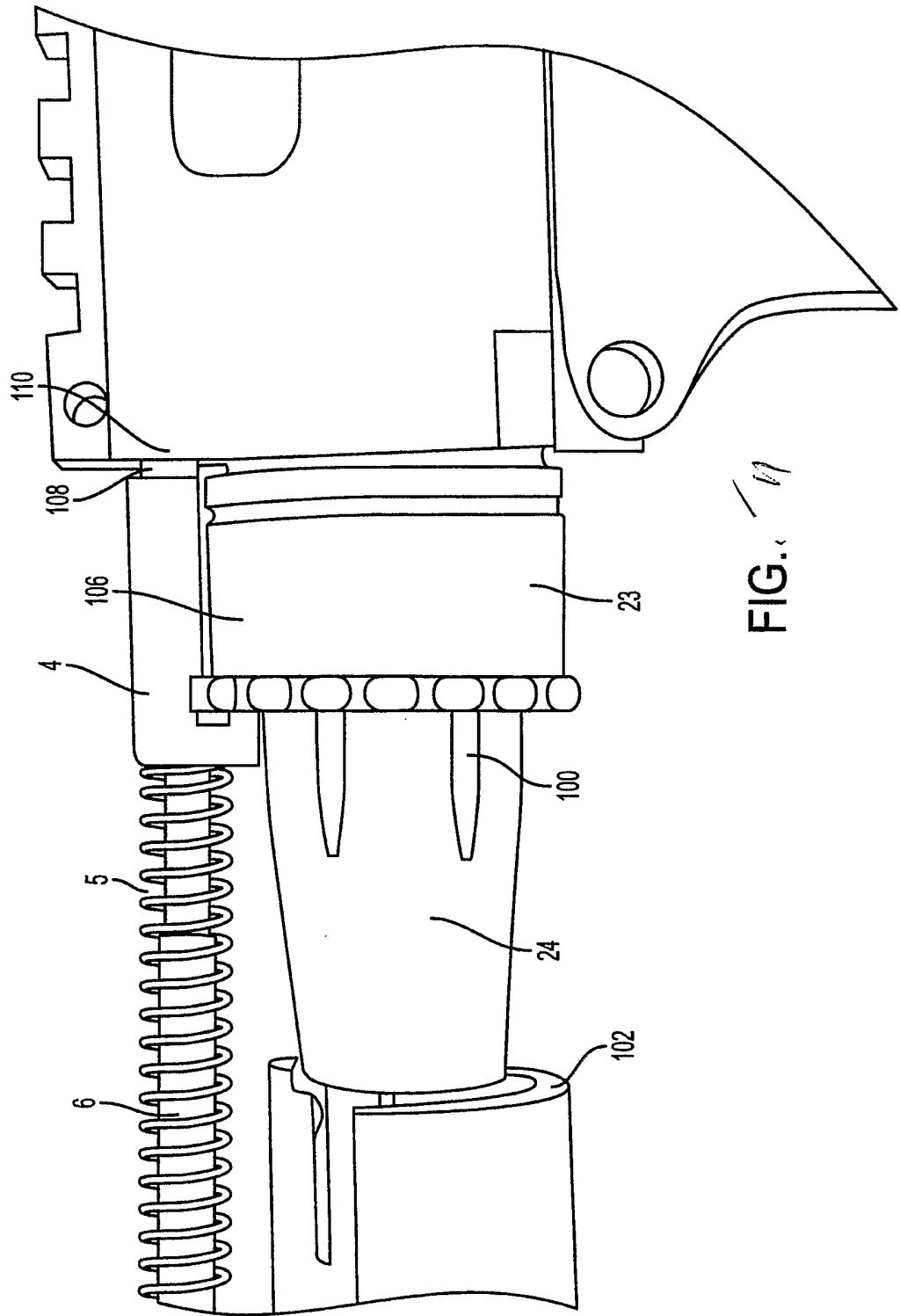

FIG. 11

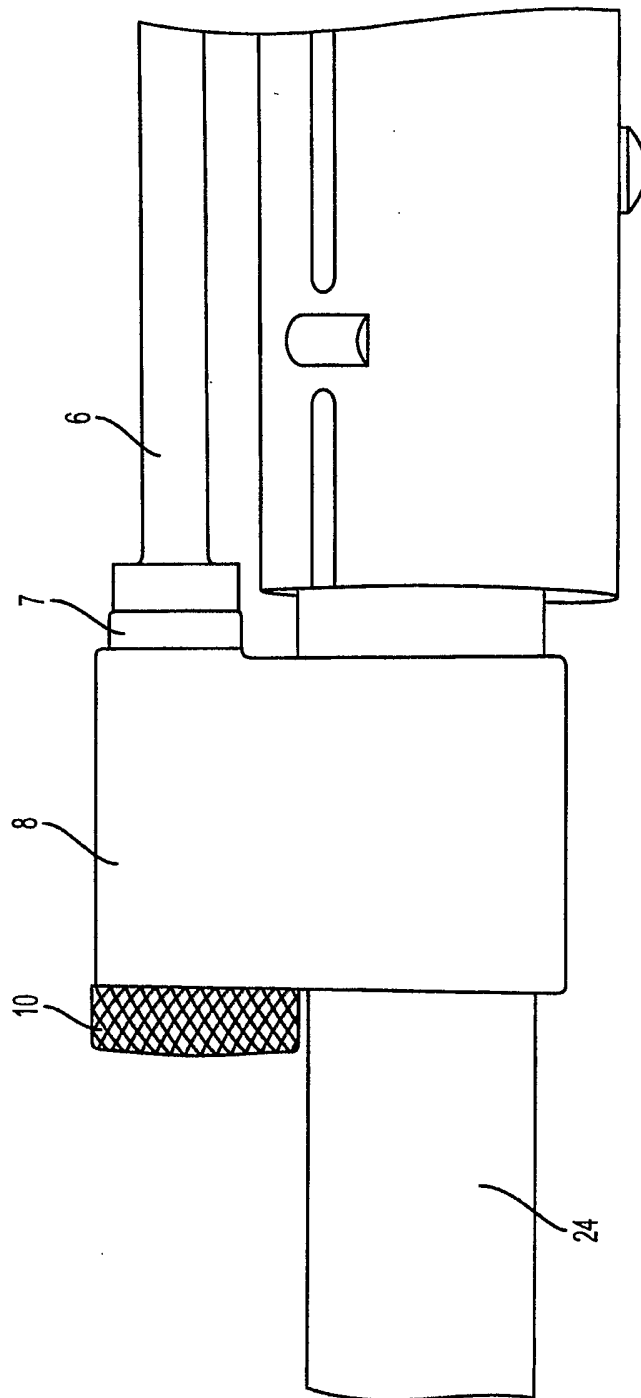

FIG. 12

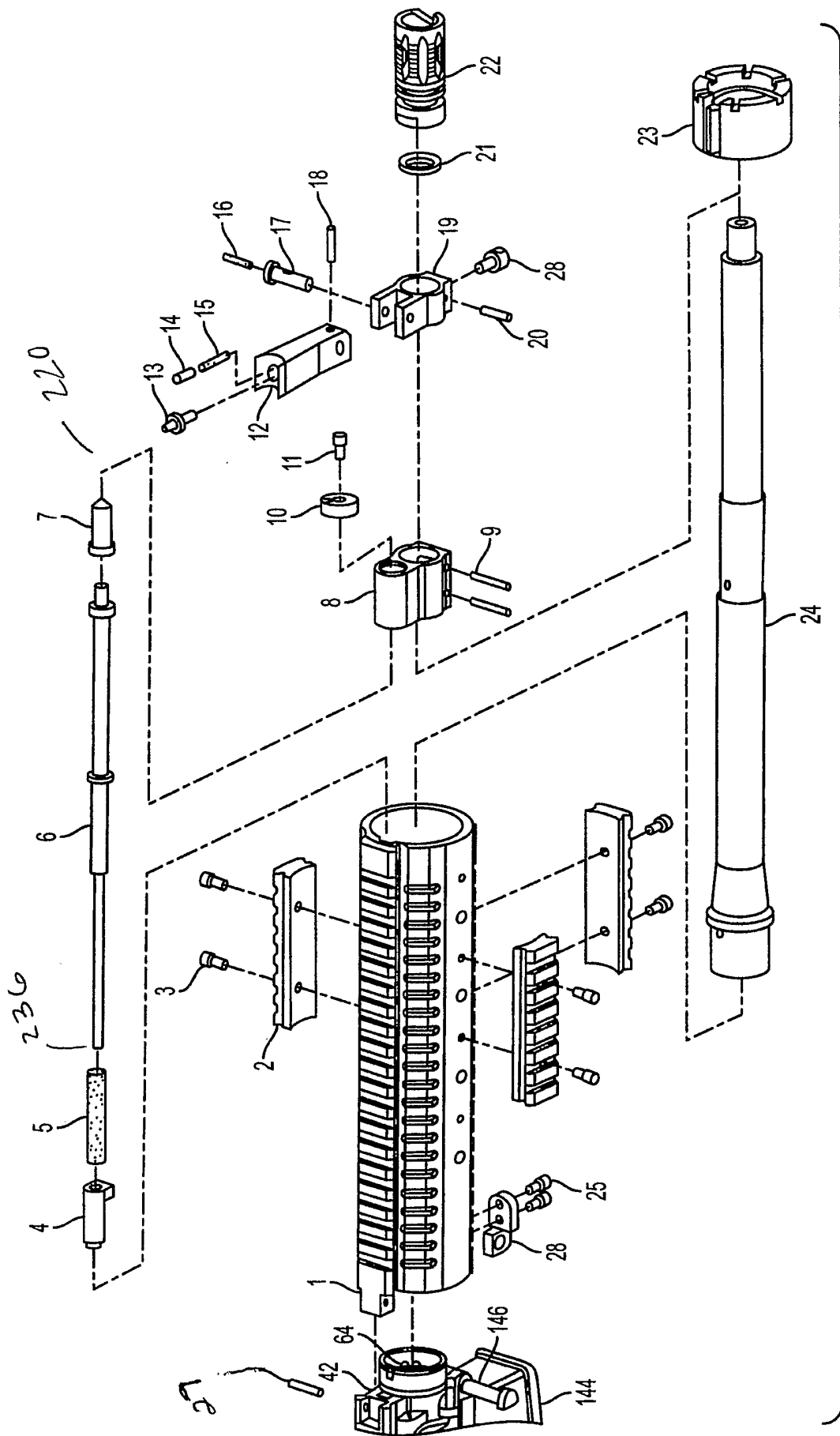

FIG. 13

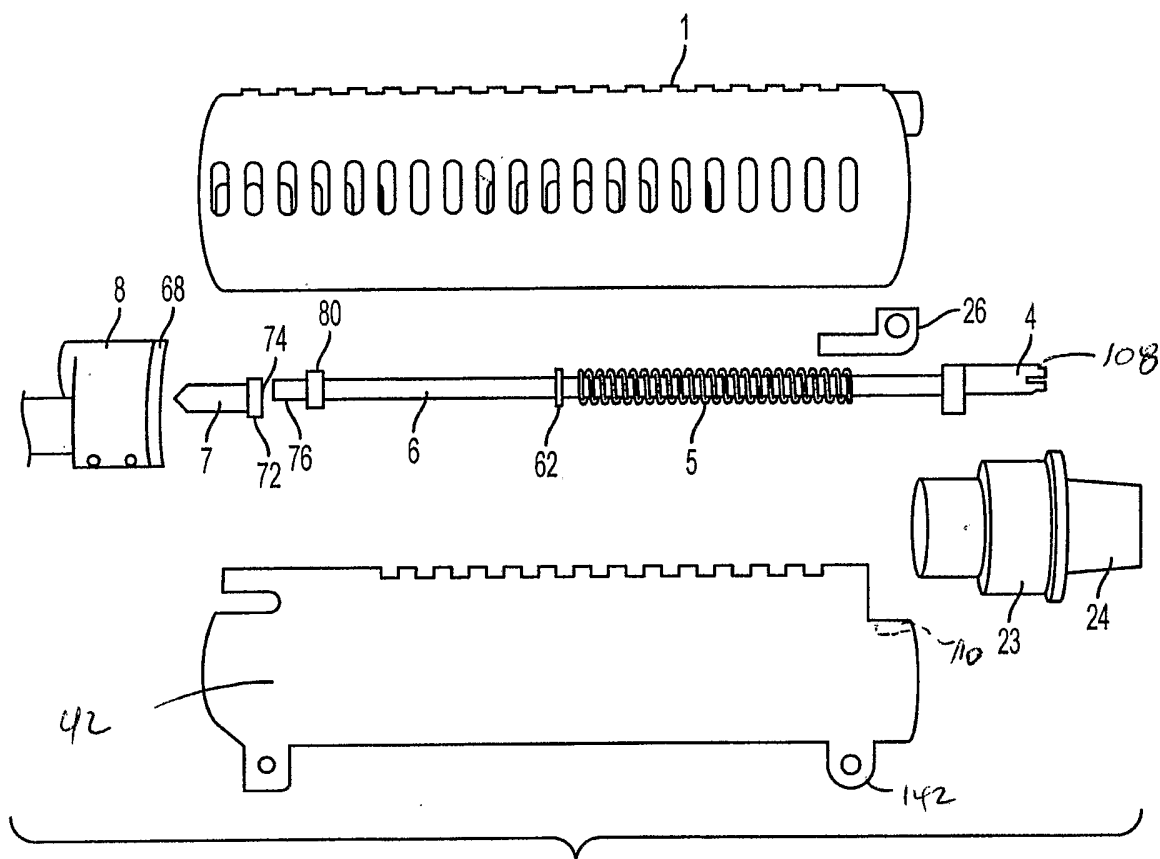

FIG. 14

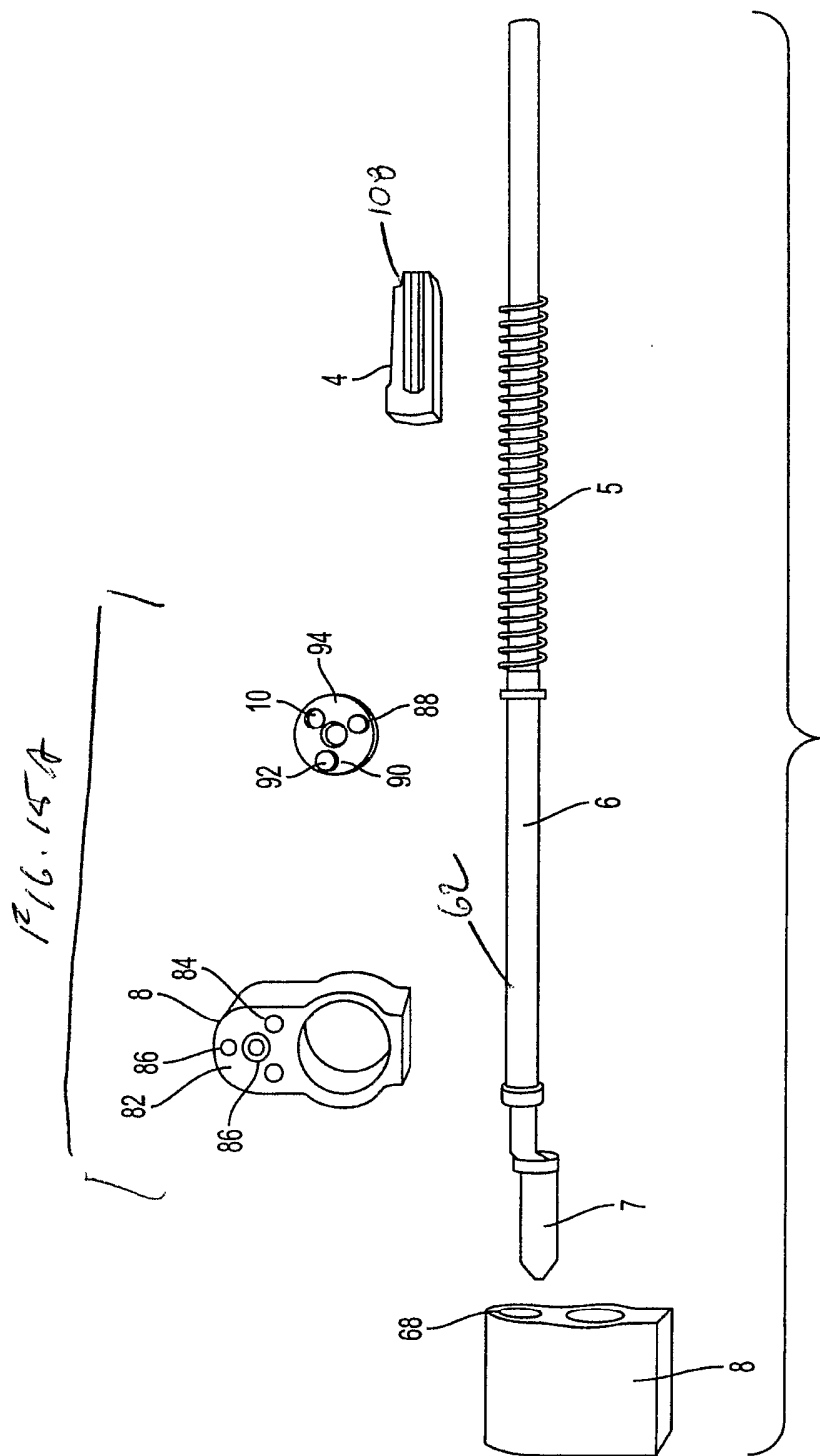

FIG. 15

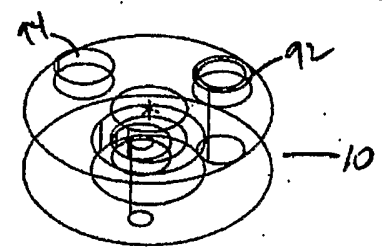
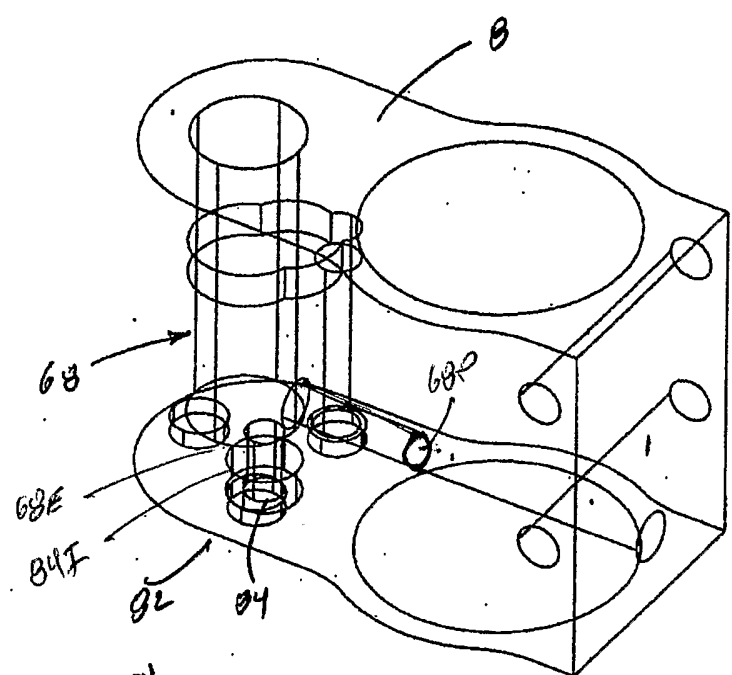

FIG. 16

FIG. 17

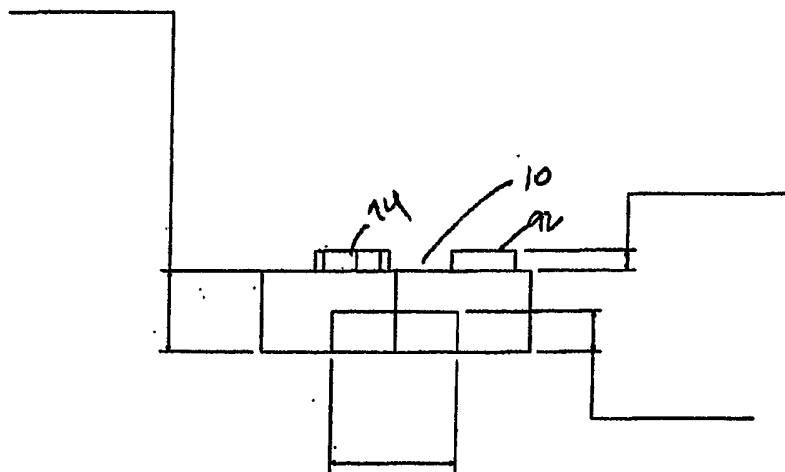
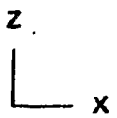

FIG. 18



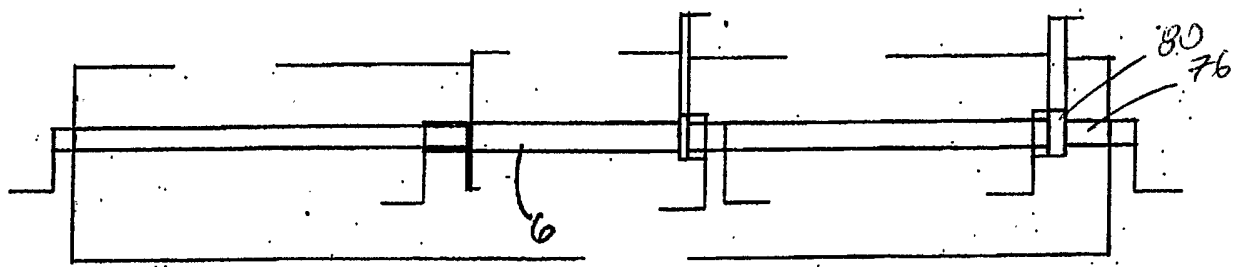

FIG. 19



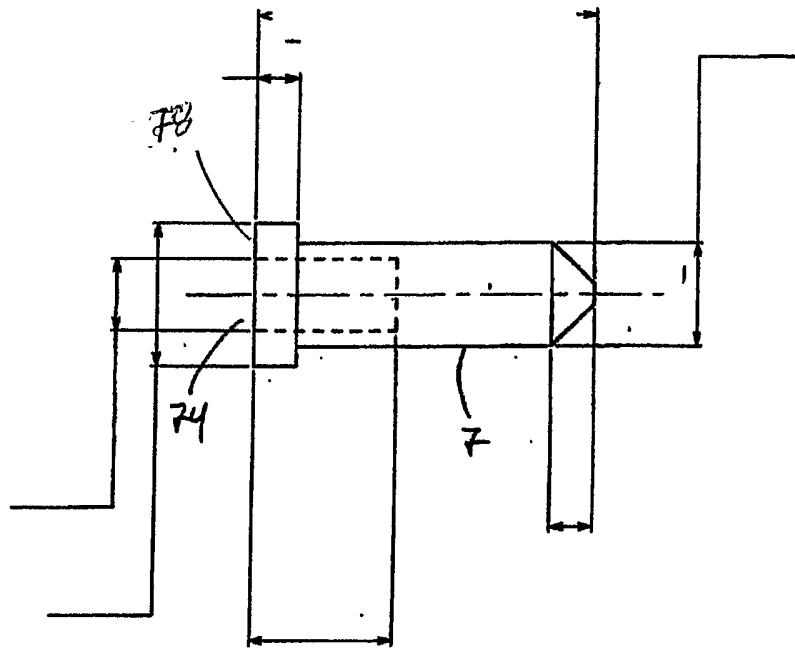
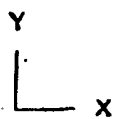

FIG. 20



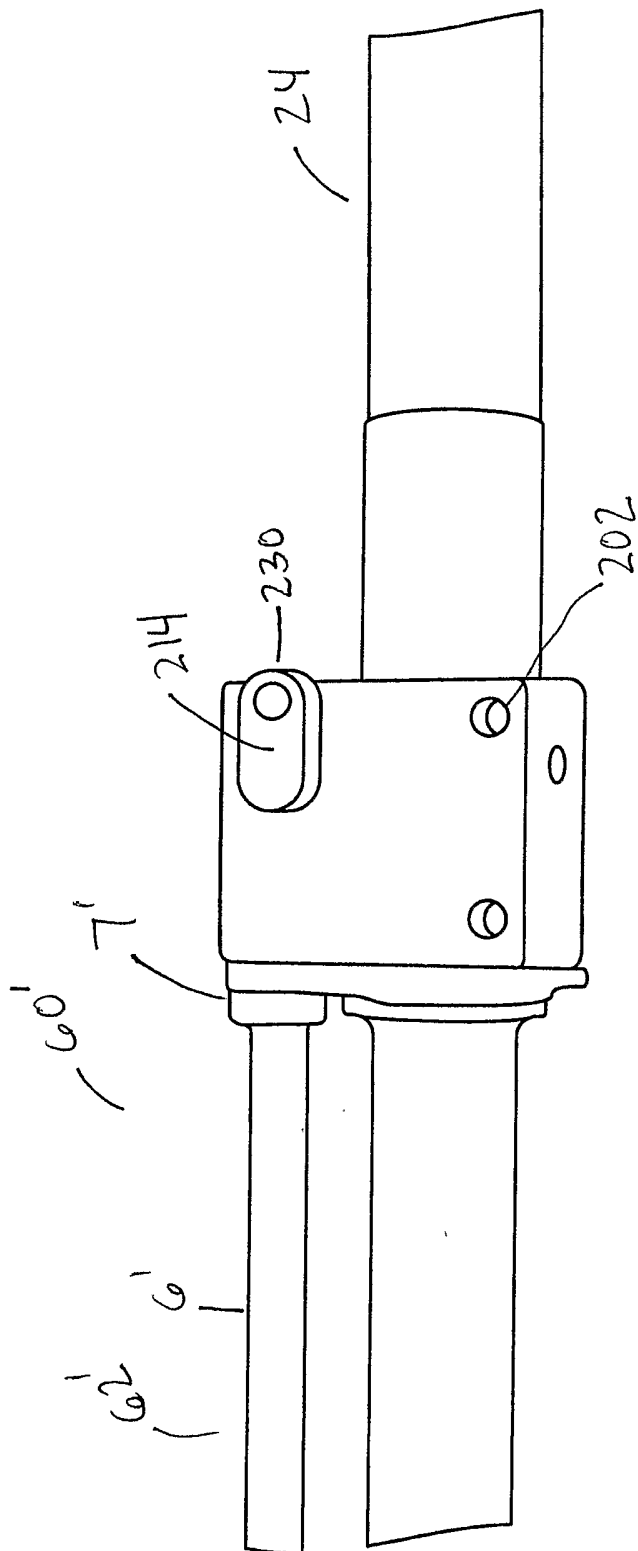

FIG. 21

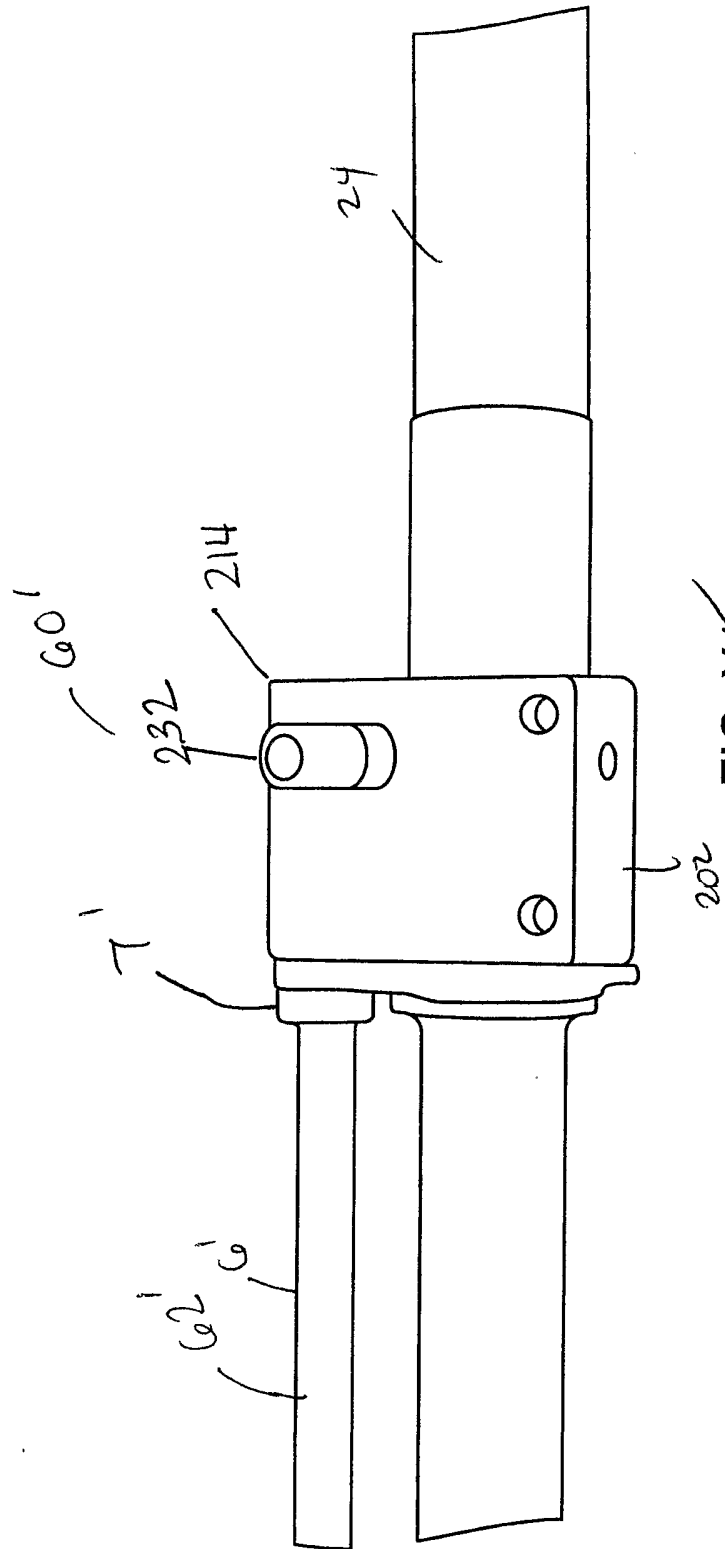

FIG. XI 22

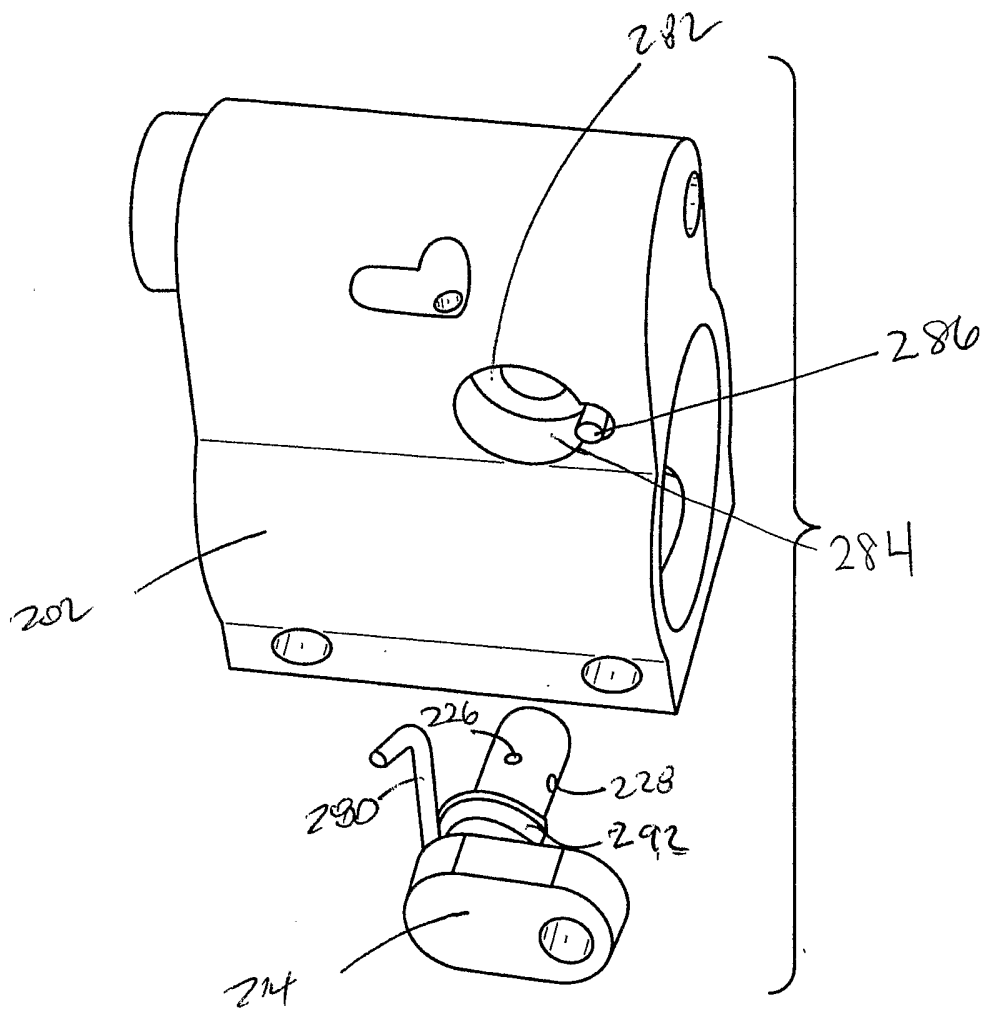
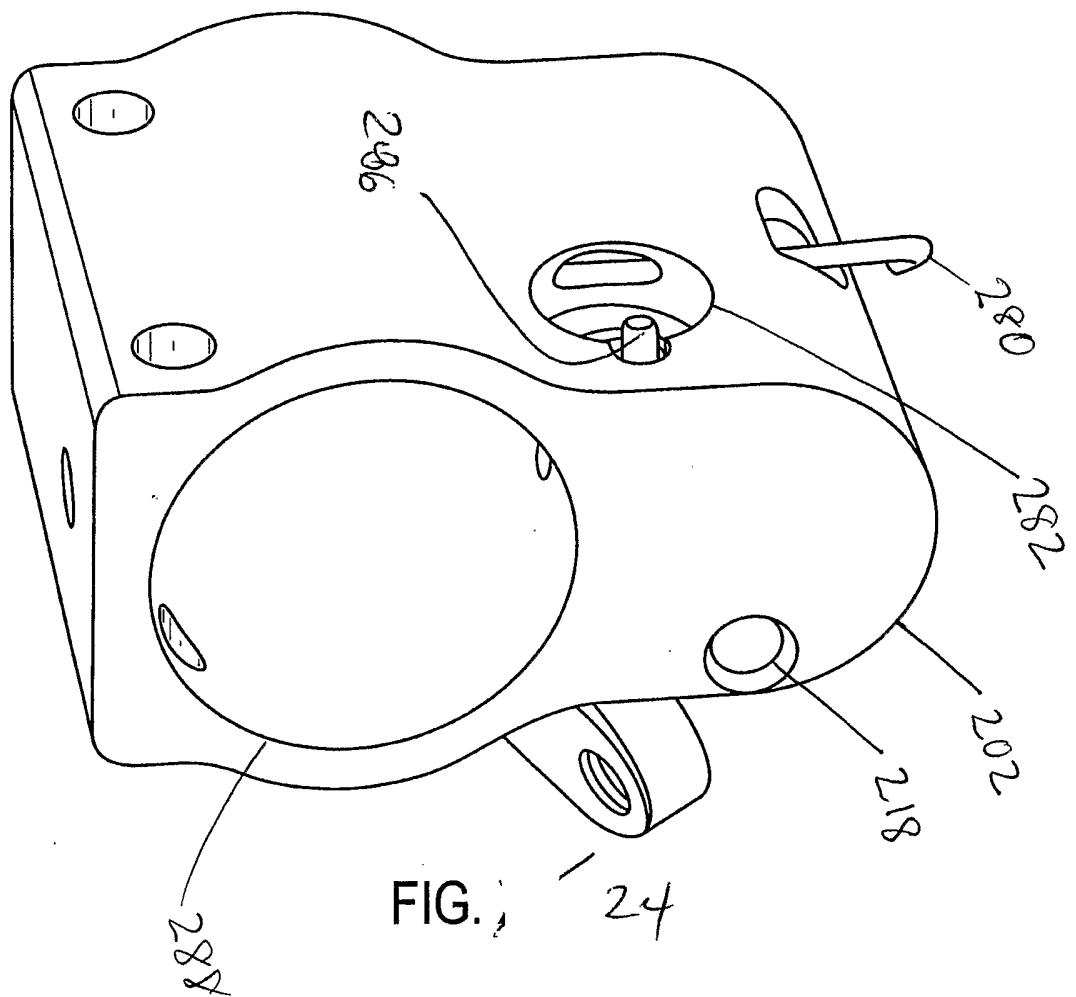

FIG. 23



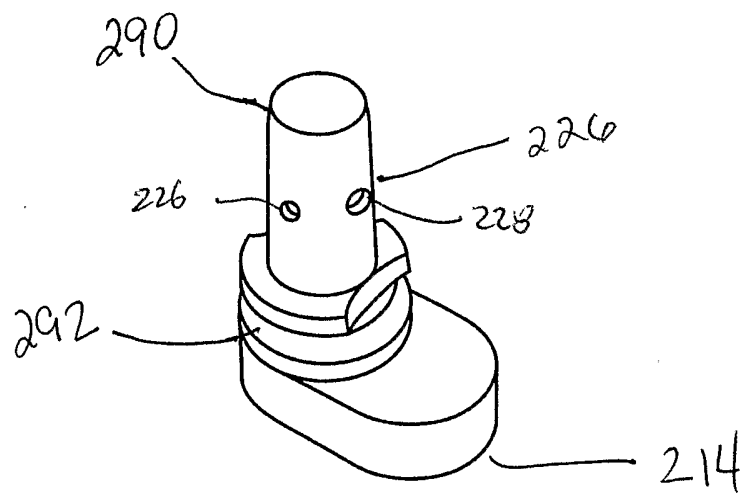

FIG. 25

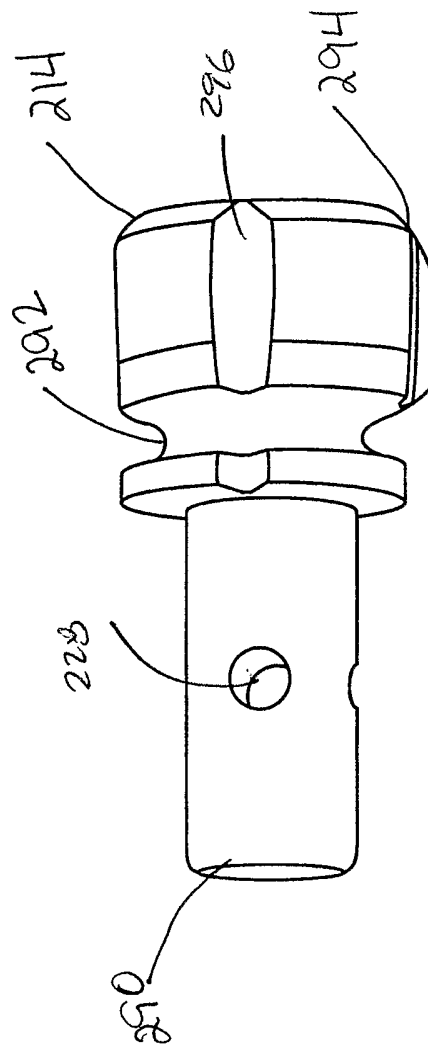

FIG. 26

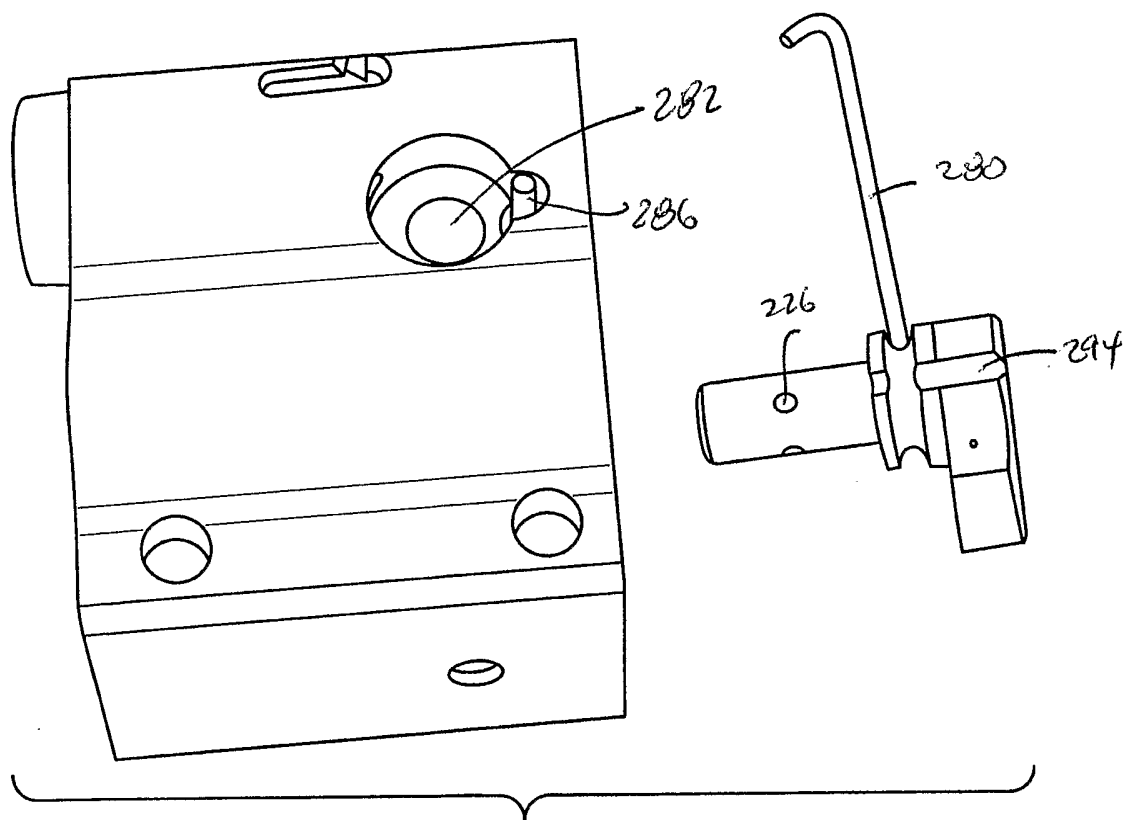

FIG. 27

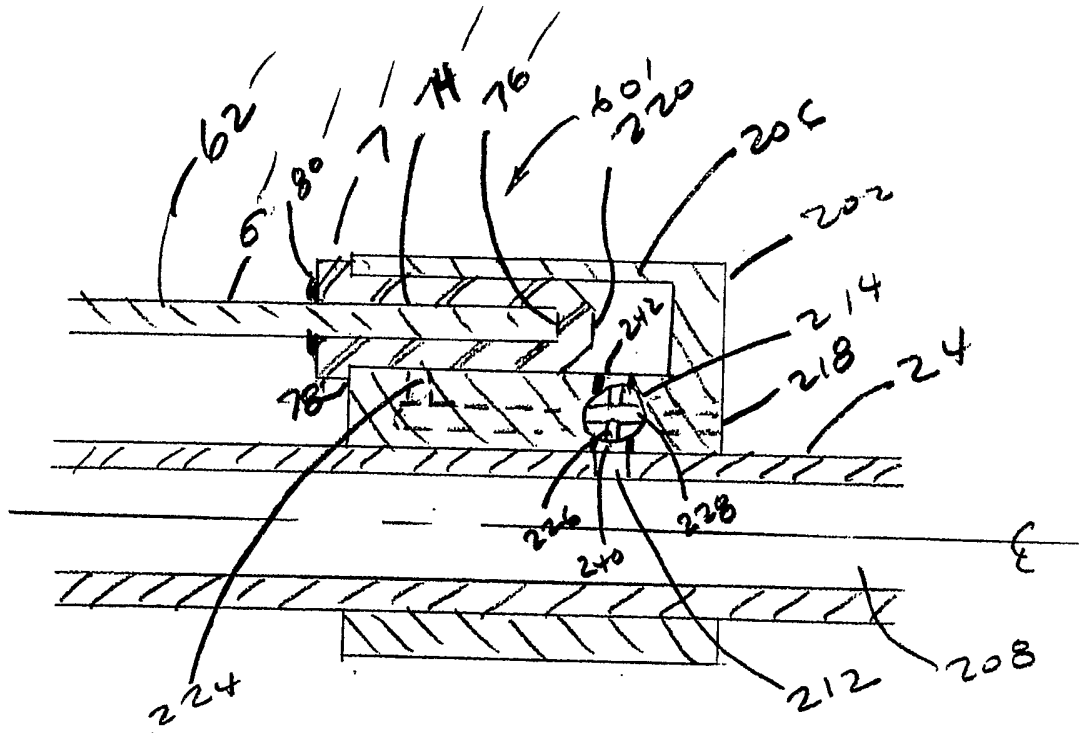

FIG 28

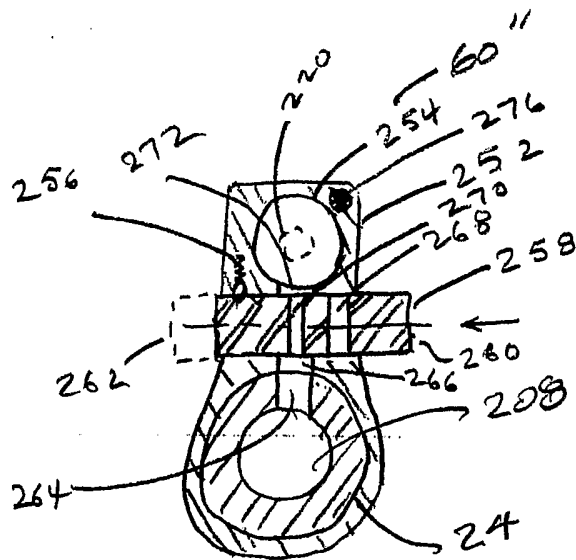

FIG 29

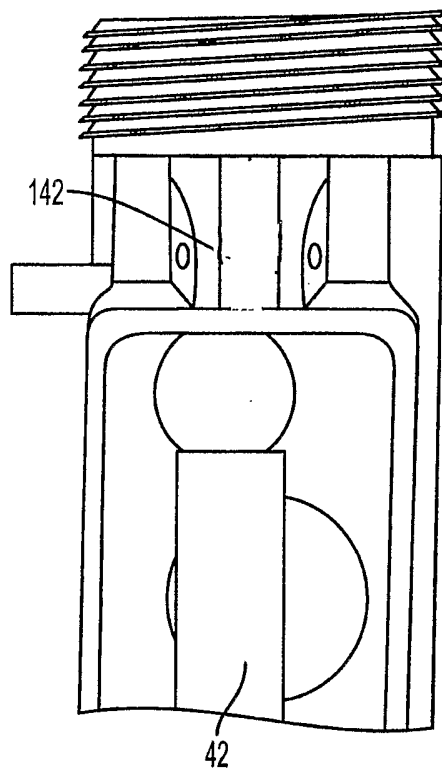

FIG. 30A

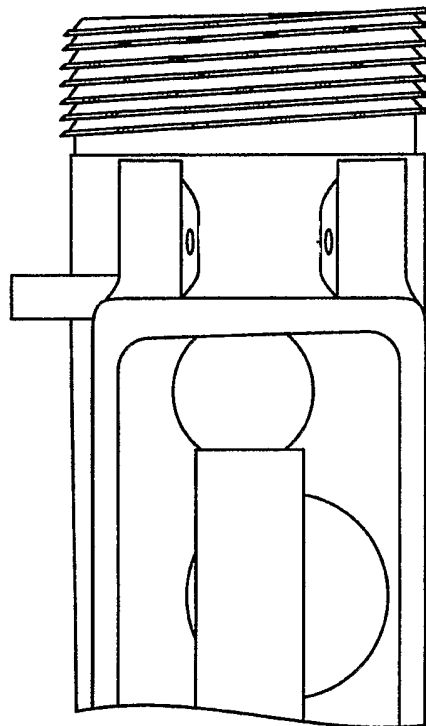

FIG. 30 B
PRIOR ART

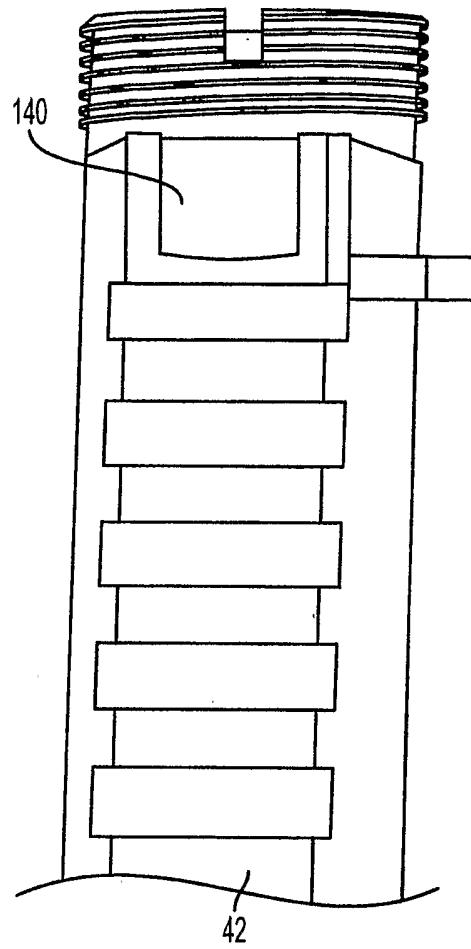

FIG. 31A

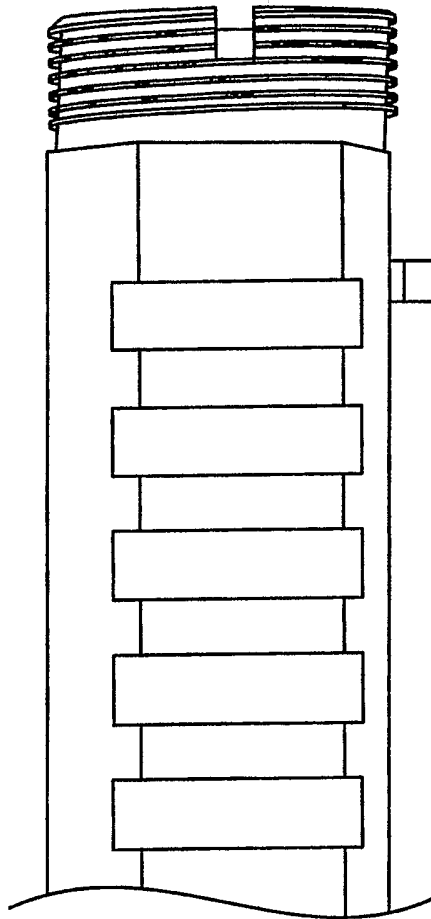

FIG. 31_B
PRIOR ART

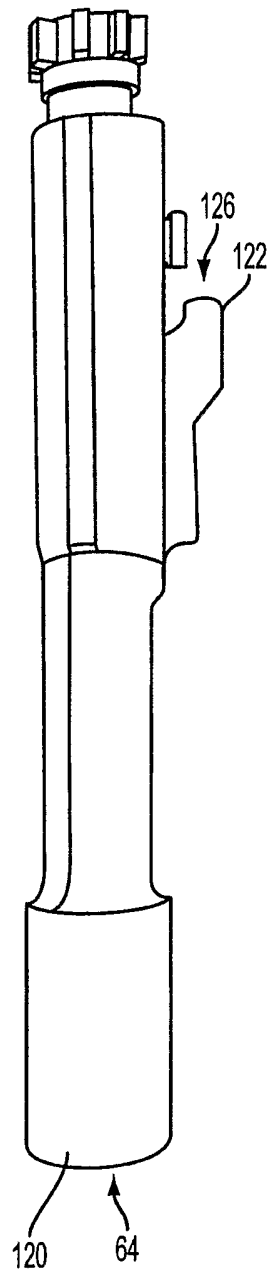

FIG. 32A

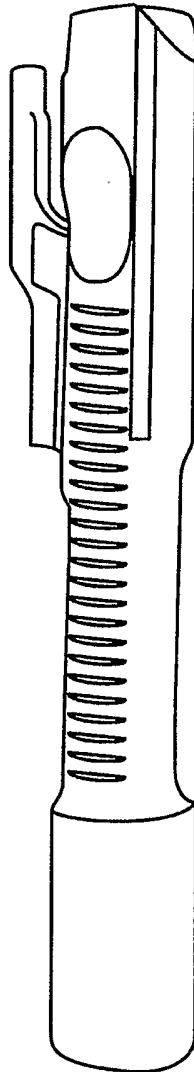
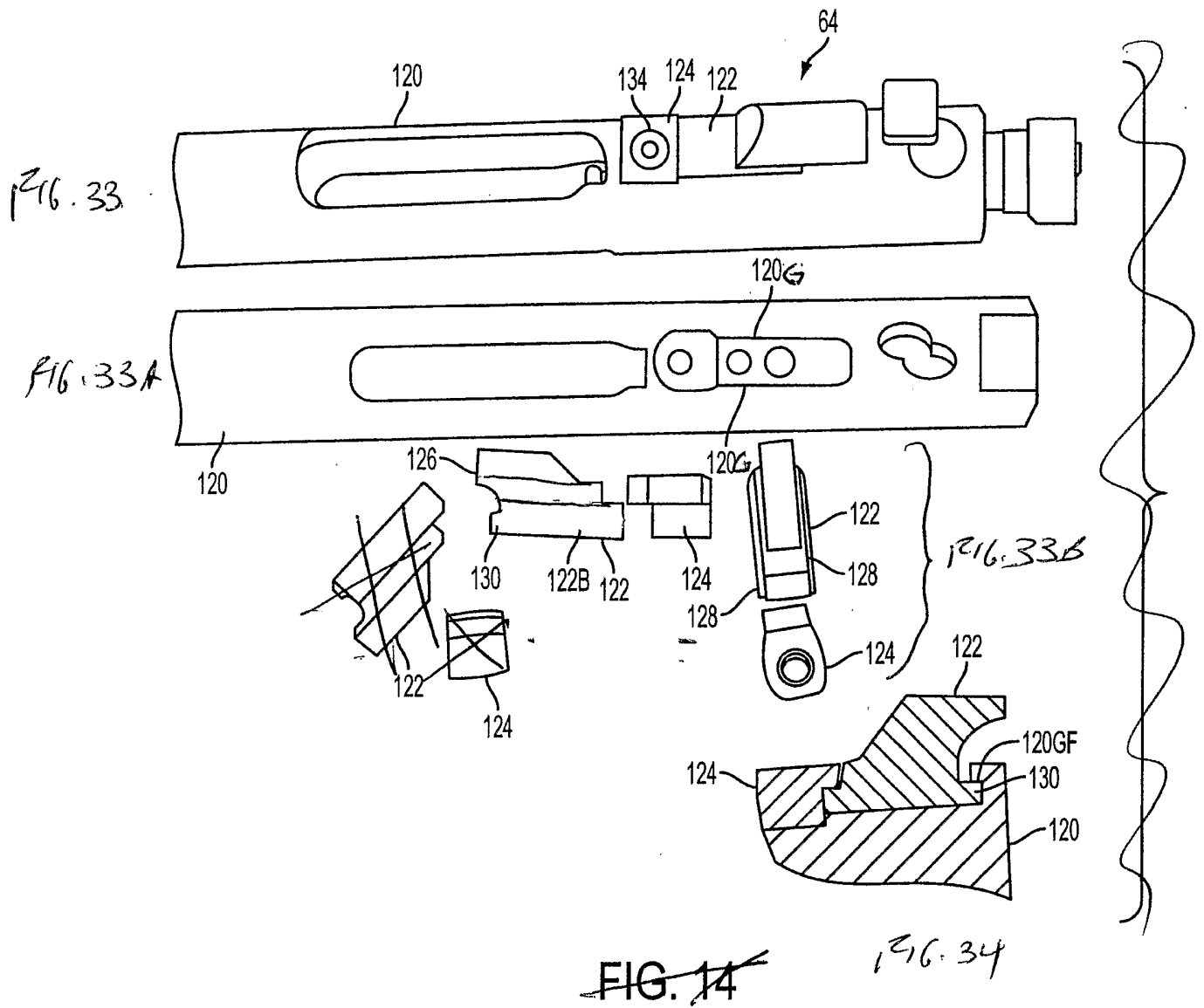

FIG. 32B
PRIOR ART



~~FIG. 14~~

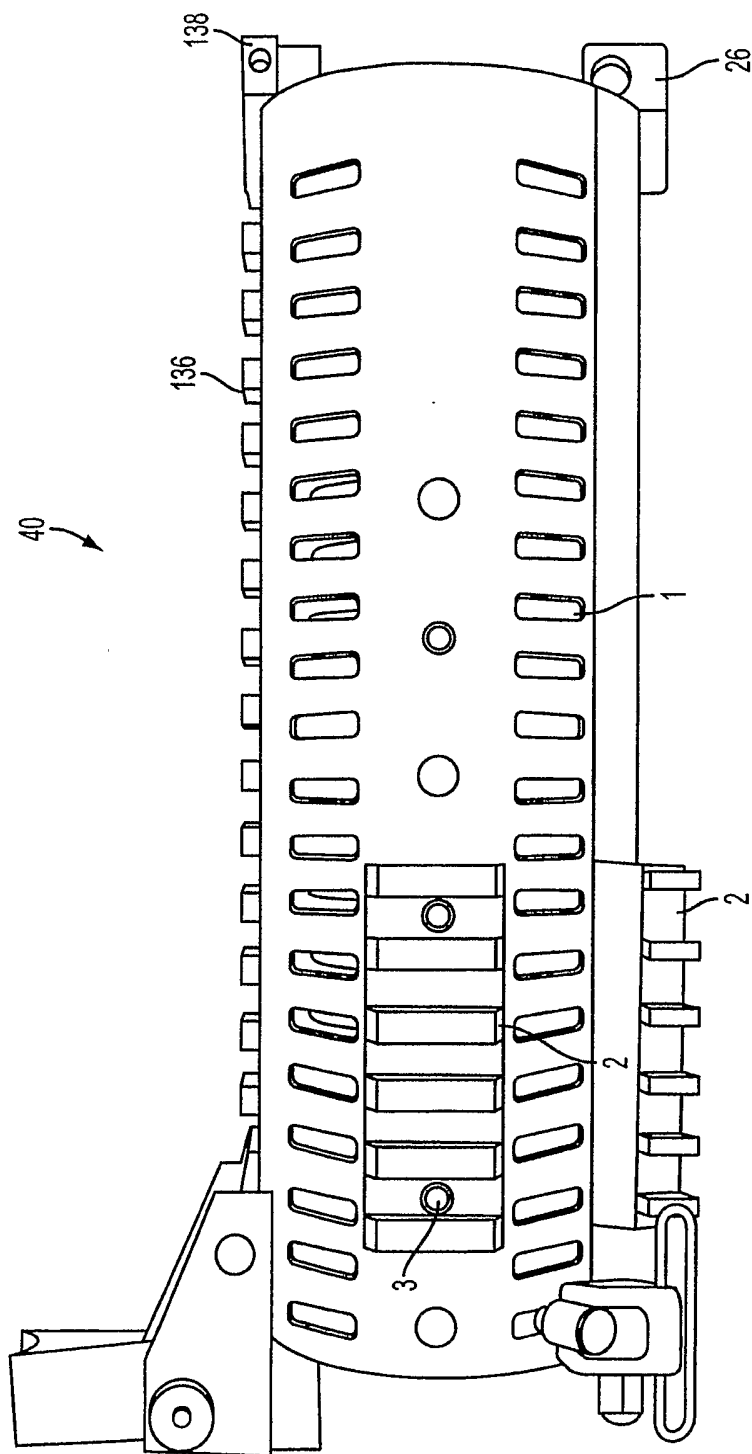

FIG. 1 135

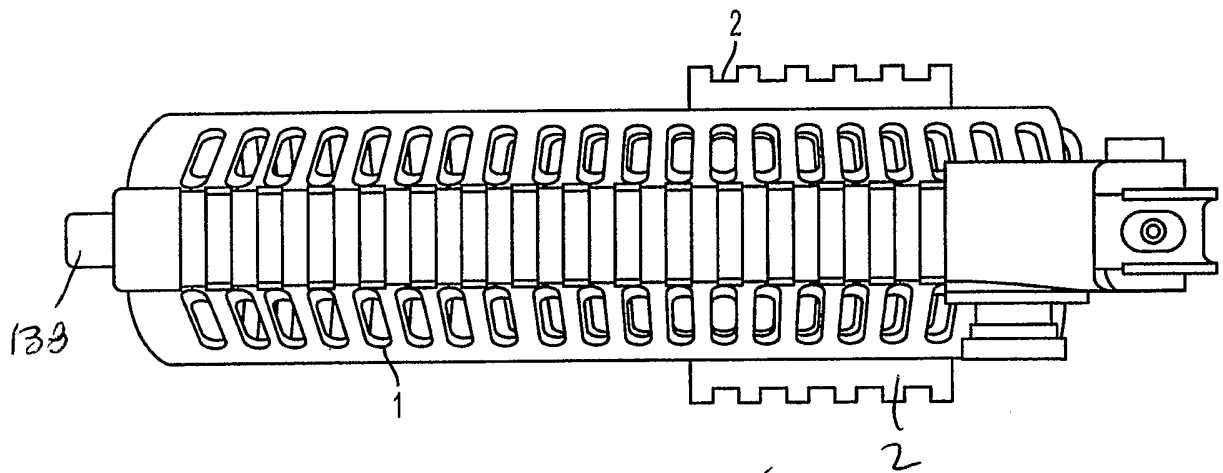

FIG. 36

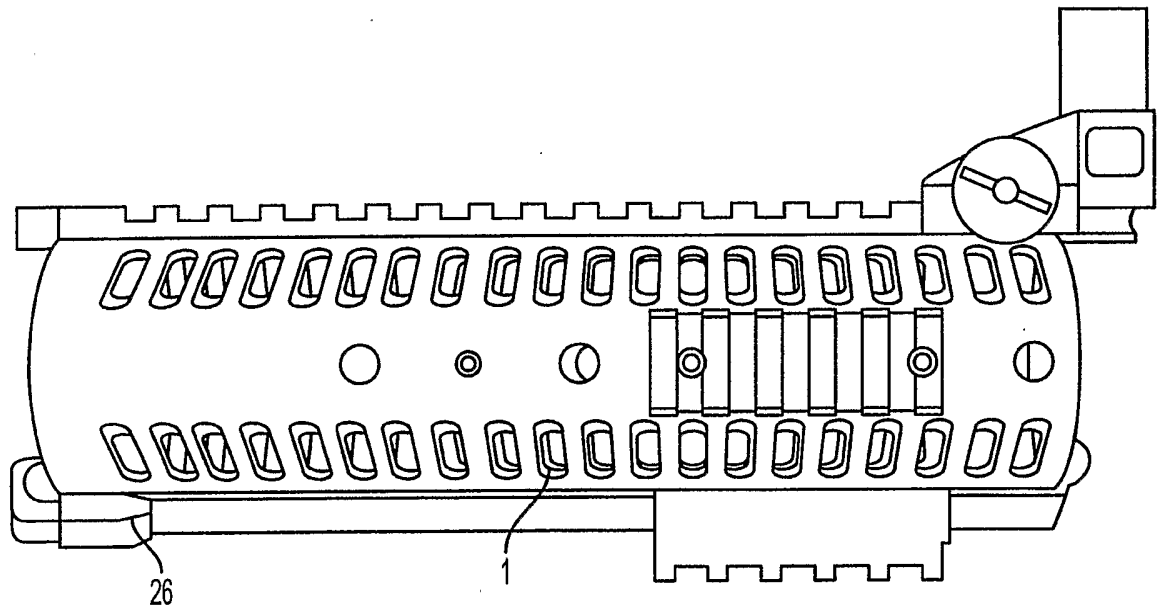
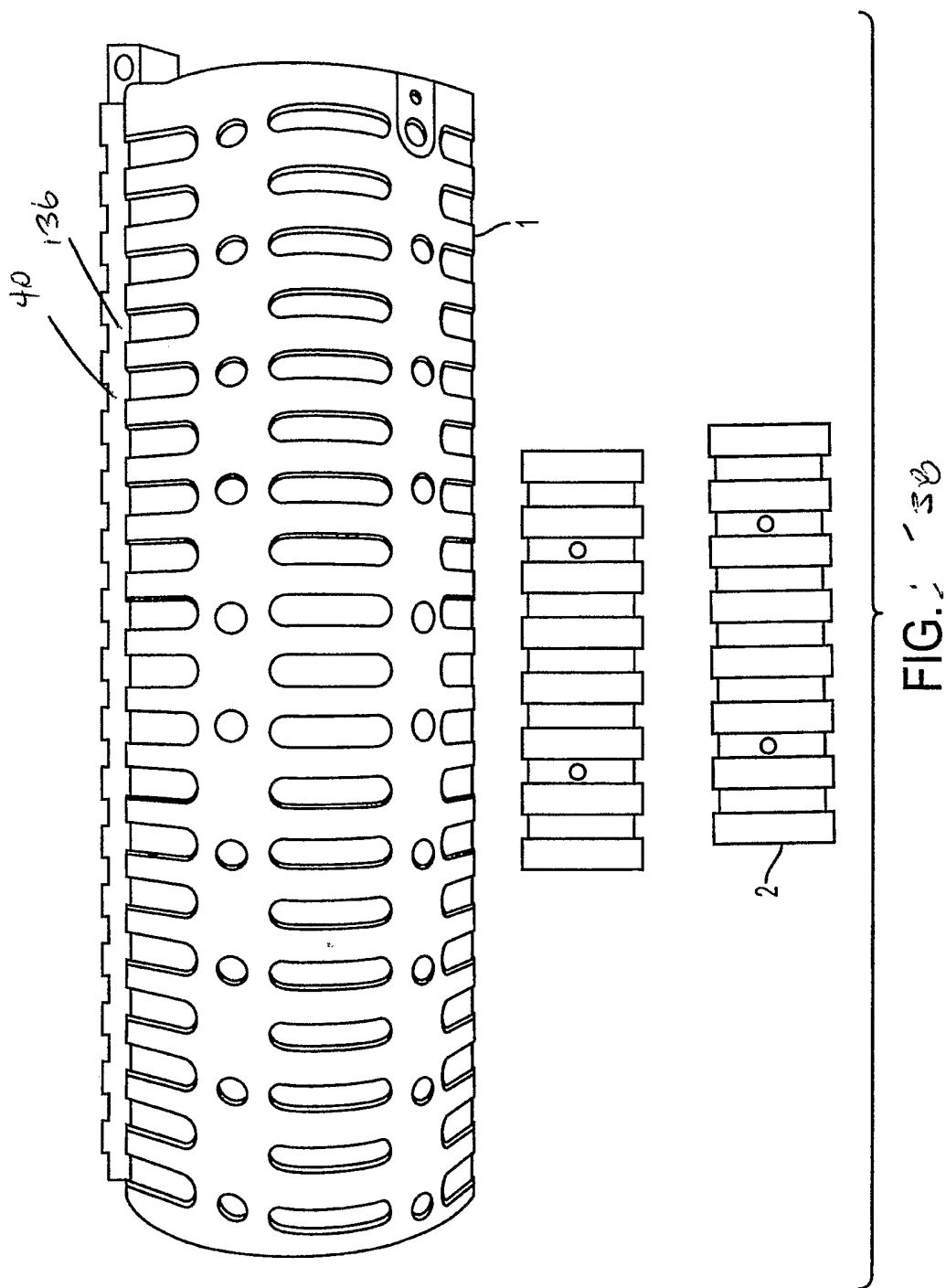

FIG. 37



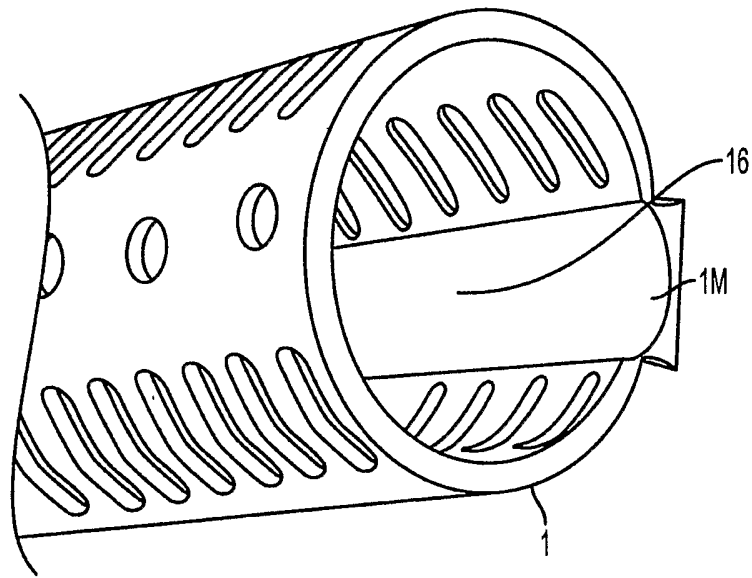

FIG. '39

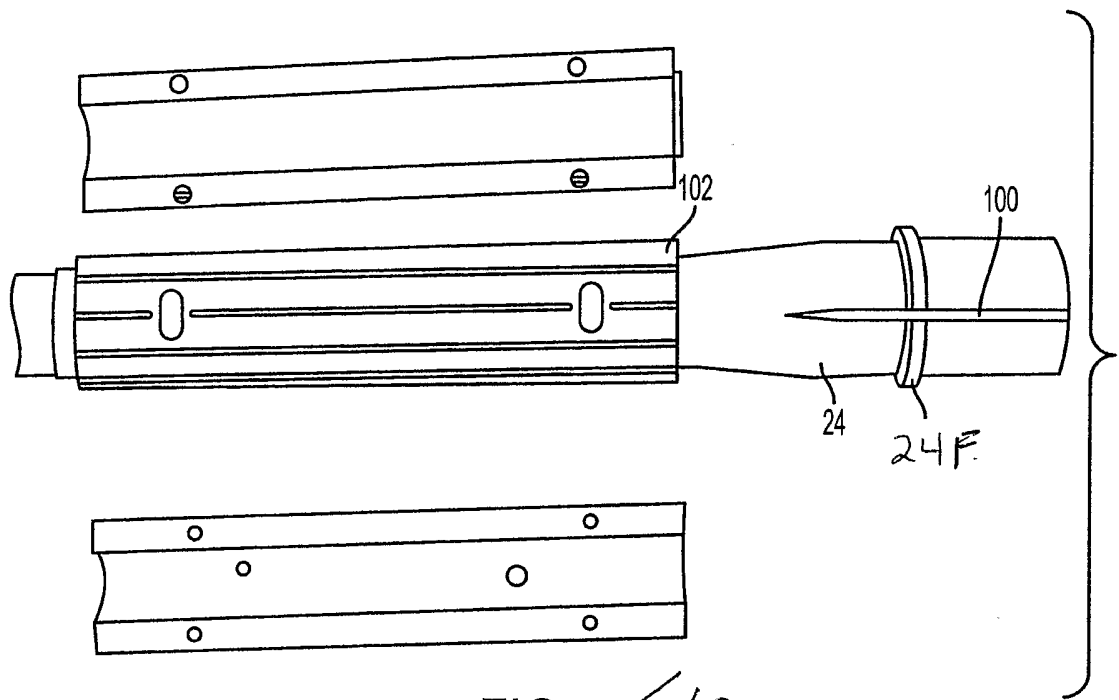

FIG. 40

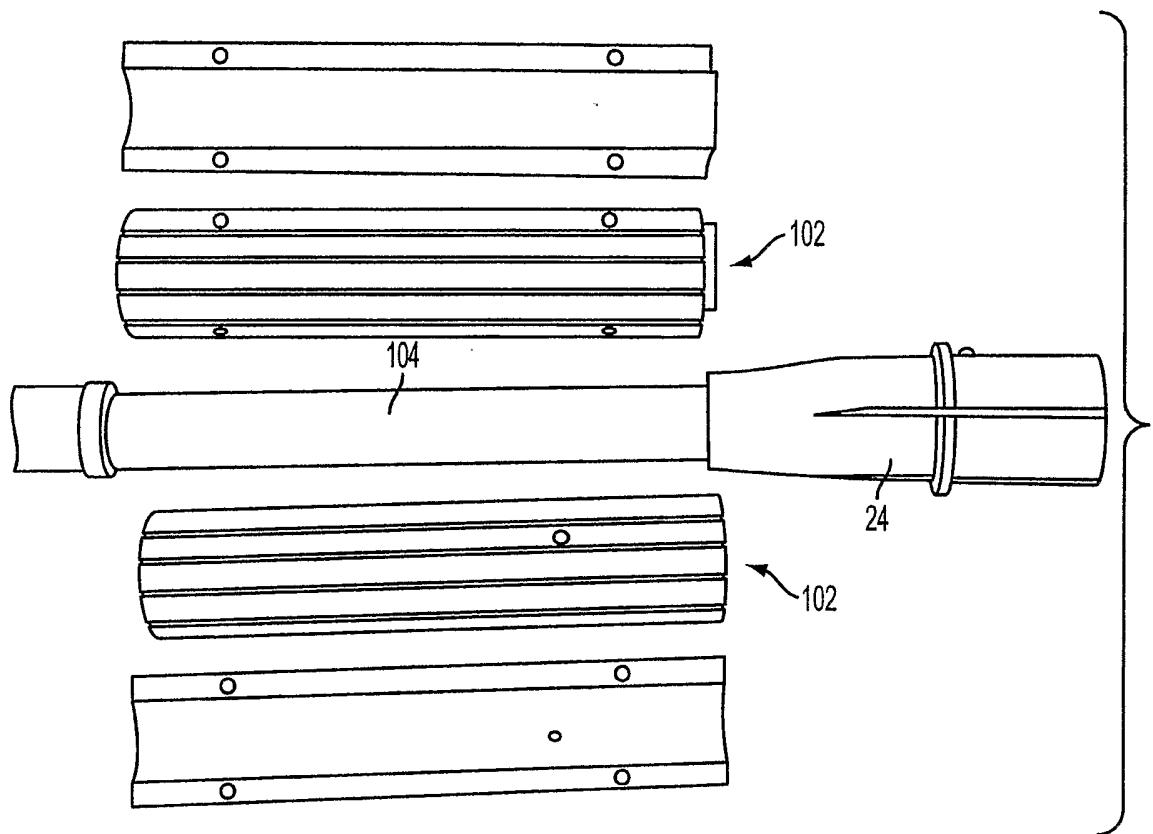

FIG. 41