

A. H. HARRISON.
 AUTOMATIC AIR COUPLER
 APPLICATION FILED SEPT. 1, 1909.

967,516.

Patented Aug. 16, 1910.

3 SHEETS—SHEET 1.

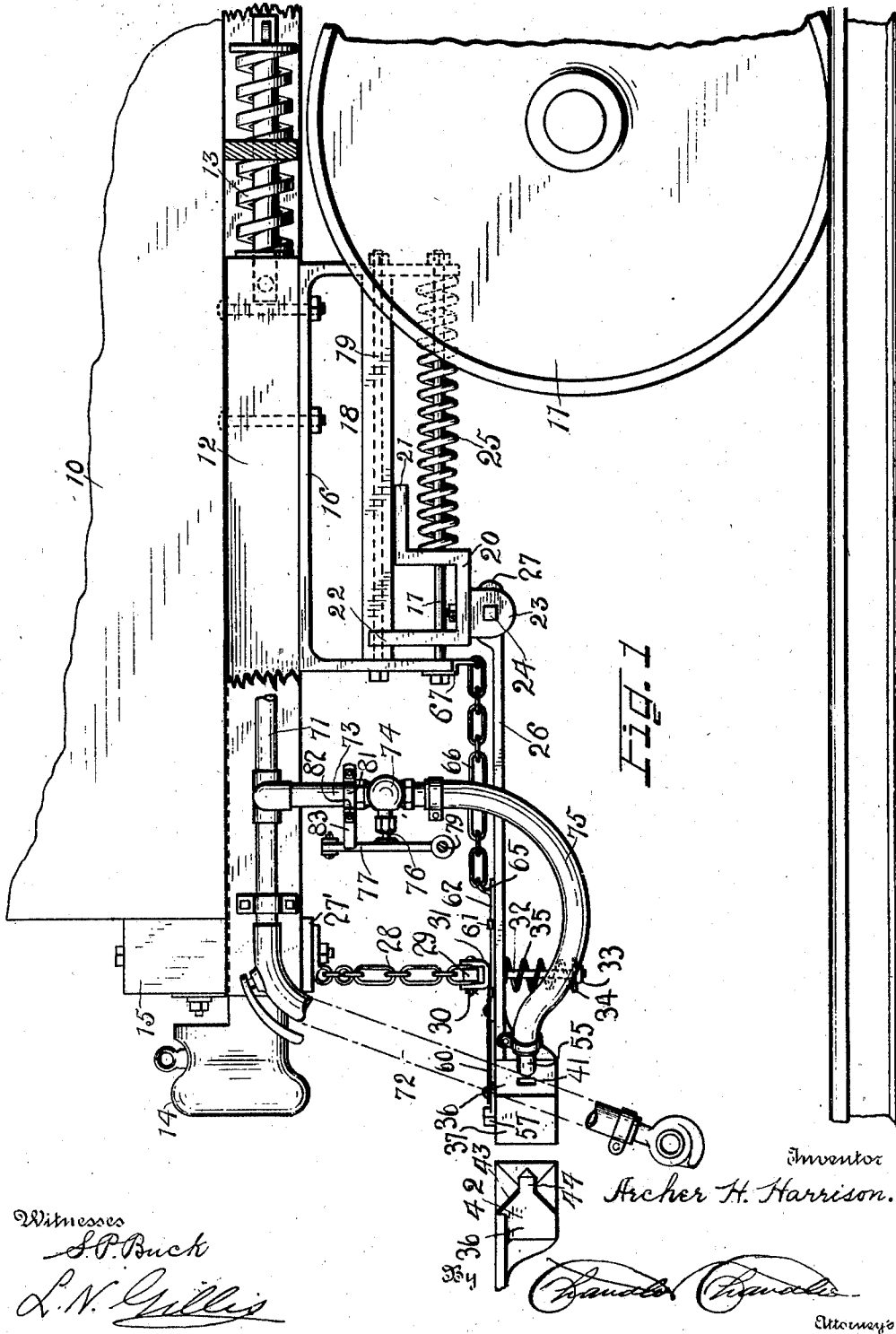

Witnesses
S. P. Buck
L. N. Gillis

Inventor
Archer H. Harrison.

Dana & Dana
 Attorneys

A. H. HARRISON.
 AUTOMATIC AIR COUPLING.
 APPLICATION FILED SEPT. 1, 1909.

967,516.

Patented Aug. 16, 1910.

3 SHEETS—SHEET 2.

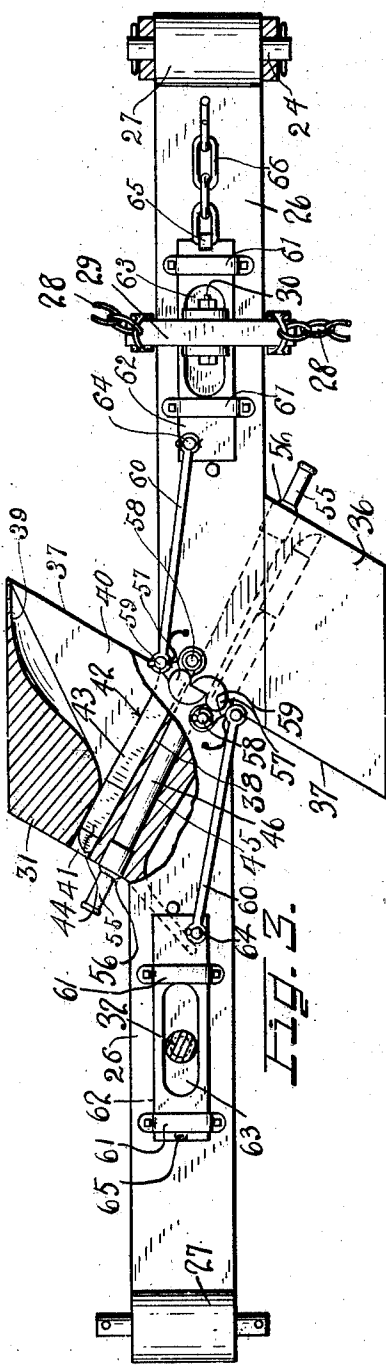

FIG. 1.

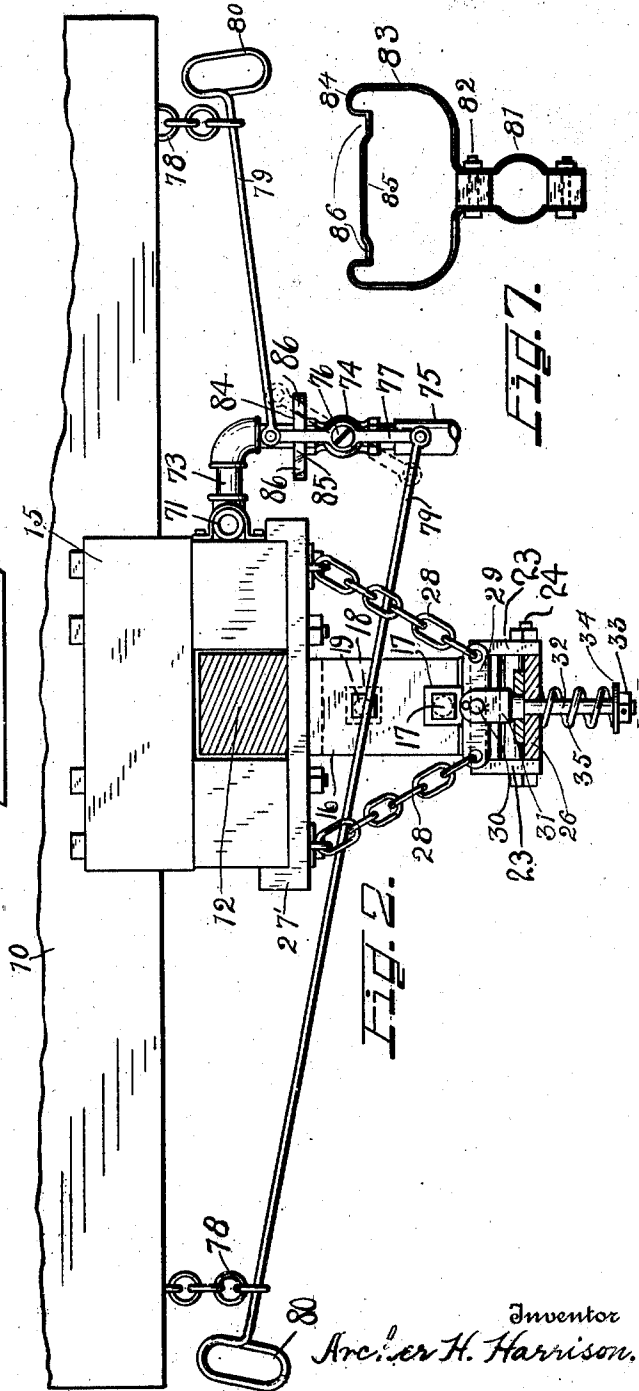

FIG. 2.

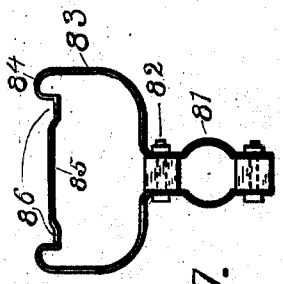

FIG. 7.

Witnesses

S. P. Buck.

L. N. Gillis

Inventor
 Archer H. Harrison.

384

Charles *Charles*

Attorneys

A. H. HARRISON.
 AUTOMATIC AIR COUPLING.
 APPLICATION FILED SEPT. 1, 1909.

967,516.

Patented Aug. 16, 1910.

3 SHEETS-SHEET 2

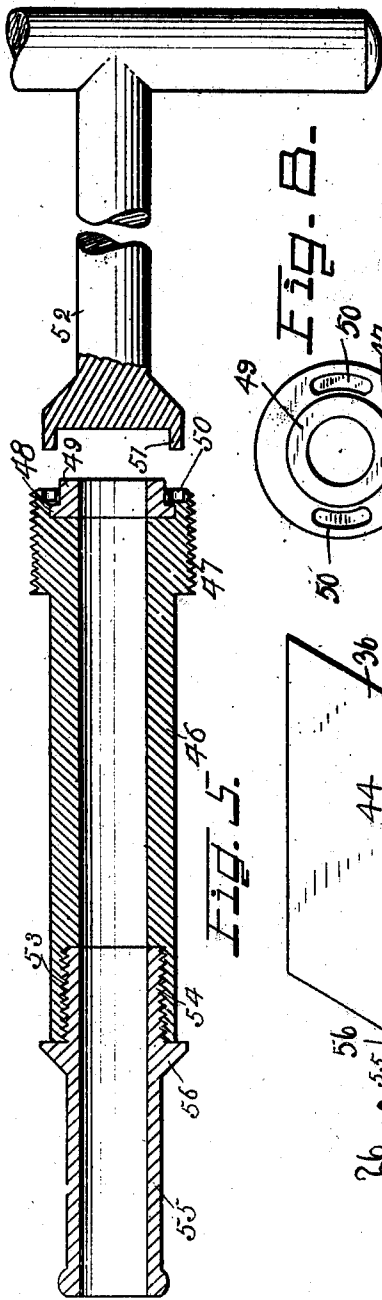

FIG. 5.

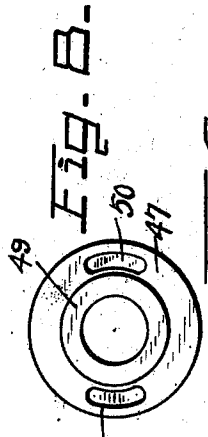

FIG. B.

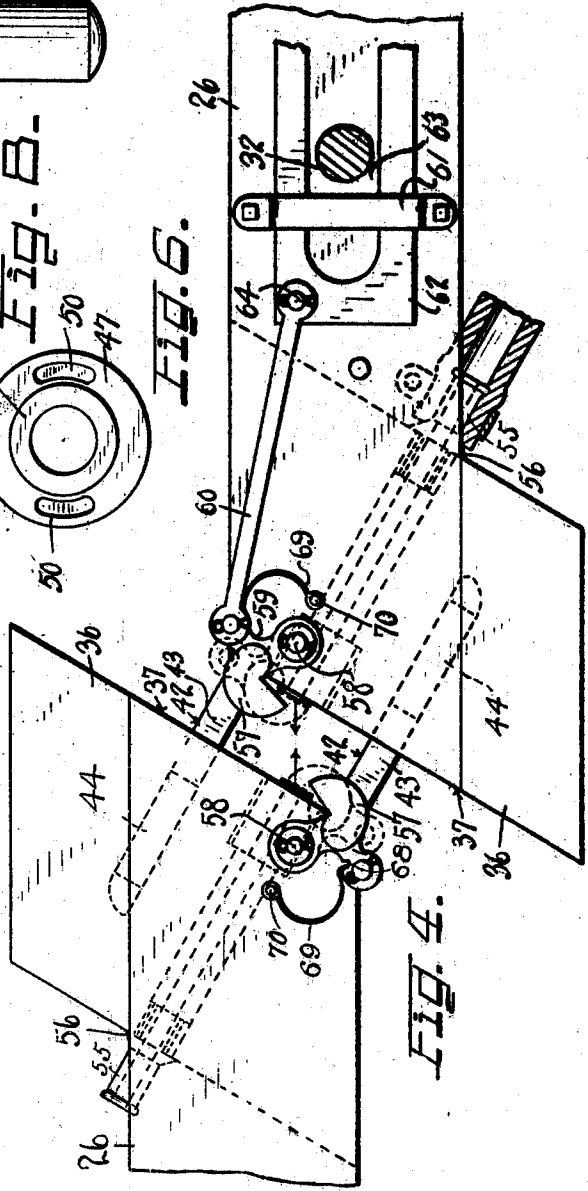

FIG. 4.

Witnesses
S. P. Buck.
L. N. Gillis

Inventor
Archer H. Harrison.

By *Donald Chandler*
 Attorney

UNITED STATES PATENT OFFICE.

ARCHER H. HARRISON, OF ORANGE, LOUISIANA, ASSIGNOR OF ONE-THIRD TO J. HENRY CAIN AND ONE-SIXTH TO J. M. CONERLY, BOTH OF ORANGE, LOUISIANA.

AUTOMATIC AIR-COUPLING.

967,516.

Specification of Letters Patent. Patented Aug. 16, 1910.

Application filed September 1, 1909. Serial No. 515,651.

To all whom it may concern:

Be it known that I, ARCHER H. HARRISON, a citizen of the United States, residing at Orange, in the parish of Vernon, State of Louisiana, have invented certain new and useful Improvements in Automatic Air-Couplers; and I do hereby declare the following to be a full, clear, and exact description of the invention, such as will enable others skilled in the art to which it appertains to make and use the same.

This invention relates to hose couplings and has special reference to a form of automatic coupling for use in coupling the air hose or steam hose of railroad trains.

One object of the invention is to provide an improved general construction of devices of this character.

A second object of the invention is to provide means whereby the hose coupling may move with the draw-bar of the car so that the couplings will not become disconnected on starting the train or jam together when the same is stopped.

A third object of the invention is to provide a novel form of coupling head for use with such devices.

A fourth object of the invention is to provide a means whereby the coupling heads may be supported to have a slight sliding movement with reference to the draw bar.

A sixth object of the invention is to provide an automatic lock for the coupling head which will operate to close as the cars are coupled and release when the cars are uncoupled after the car couplers clear each other so that the operations of coupling and uncoupling the cars and air are successive ones.

With the above and other objects in view the invention consists in general of a frame attached fixedly to a draw bar, in combination with a novel form of coupling head and connection therefor, the coupling head and connection being supported from the frame and from the car, together with improved means for locking two coupling heads together.

The invention further consists in certain novel details of construction and combinations of parts hereinafter fully described,

illustrated in the accompanying drawings, and specifically set forth in the claims.

In the accompanying drawings, like characters of reference indicate like parts in the several views, and Figure 1 is a side elevation of a portion of a car constructed in accordance with this invention, a small portion of an adjoining coupling head being shown. Fig. 2 is a front elevation of a car constructed in accordance with this invention, the greater part of the car being broken away and a portion of the device being shown in section. Fig. 3 is a top plan view of a pair of couplers disconnected from the supporting frames and car, the couplers being shown partly in section the better to bring out the details. Fig. 4 is an enlarged view of two coupler heads in the position assumed just before coupling. Fig. 5 is an enlarged detail view of the hose attaching nipple used with this invention, the tool for applying the same being also shown in this view. Fig. 6 is a face view of one end of this nipple. Fig. 7 is a detail view of an air valve lock used with this invention. Fig. 8 is a face view of the nipple shown in Fig. 5.

The numeral 10 indicates a portion of the body of a car and this car is supported on the usual wheels 11; the details of the truck being omitted as the same form no part of this invention. Supported between the usual center sills is a draw bar 12 provided with the usual spring buffer 13 and on the outer ends of this draw bar is fixed a coupler head typified at 14. At 15 is indicated one of the end sills of the car. It will be understood throughout that each of the cars to be coupled with this invention is similarly provided and the coupling heads and all parts will be precisely alike throughout.

Bolted to the under side of the draw bar 12 is an inverted U-shaped frame 16 the arms of which are connected at their extremities by a rod 17 and between their extremities by a guide 18 mounted upon a rod 19. Slidable on the bar 17 is a sliding member 20 of U-shape, one of the arms being bent outward to lie beneath the bar 18 as indicated at 21 while the other arm is provided with a notch and extends up along

each side of the bar as indicated at 22. This sliding member is provided with downwardly depending opposed ears 23 provided with suitable perforations to receive a bolt 24. This sliding member 20 is furthermore normally held pressed forward by means of a coil spring 25 which is carried on the bar 17, one end of the coil spring bearing against the sliding member while the other end bears against the rear arm of the U-shaped frame 16.

The coupling head is provided with a shank 26 which has at its rear end an enlarged eye portion 27 suitably perforated to receive the bolt 24. The coupling head is thus connected to the sliding member 20 and can consequently yield with respect to the draw bar 12, the yielding being permitted by the compression of the spring 25. Beneath the draw bar at the forward end thereof is the usual draw bar carry iron 27' on which the forward end of the draw bar rests. Suspended from this draw bar carry iron at points adjacent the opposite ends thereof are chains 28 which are connected at their lower ends by means of a yoke 29. This yoke is perforated centrally to receive a bolt 30 which passes through the fork 31 of a hanger bolt 32 provided on its lower end with a nut 33 and collar 34. This hanger bolt passes through the shank 26 and the latter is freely slidable on the hanger bolt, being kept in elevated position by means of a suitable coil spring 35 which is held between the under side of the shank and the washer 34. By this means the forward end of the shank is suspended to permit of slight swinging movement and also of some twist and rise and fall.

Carried on the shank 26 is a coupling head 36 the forward face whereof is beveled as indicated at 37. This coupling head is provided with a recess for the reception of a guide pin and this recess consists of a flat or plane inside wall 38, a gently curved outside wall 39 and inclined top and bottom walls 40. By means of this construction the mouth of the recess is considerably larger than the interior and tapers gradually on three sides to a flat back wall. In this head there is an opening 41 the back wall of which forms a continuation of the wall 38 and this opening merges gradually into the recess previously described. This opening 41 is furthermore preferably rectangular in cross section.

Rigidly mounted on or formed integral with each of these coupling heads is a guide plate 42 having upper and lower edges 43 corresponding in incline to the upper and lower surfaces 40 and oppositely arranged, these surfaces being for the purpose of engaging the upper and lower surfaces 40 of an opposed coupler. This guide plate 42 terminates in a guide finger 44 which is of

such shape as to enter the opening 41 and the guide plate thus acts not only as a guide but as a stop since the plate, when a coupler is locked to another, will bear against the wall 38 of the guide recess.

It will now be plain that no matter in what position the guide finger 44 of one guide plate may strike the recess of another coupling head the two will be caused to position properly for coupling since the finger 44 of each will be guided into the opening 41 of the opposed coupling. These coupling heads are each further provided with an opening 45 extending therethrough and in this opening 45 is held a nipple for the attachment of air hose. This nipple consists of a central body portion 46 having an enlarged threaded end 47 and this threaded end is bored out as at 48 to form a channel for the reception of a washer 49 of some flexible material possessing elasticity such as leather, rubber or the like. Furthermore, this enlarged end 47 is provided with tool receiving recesses 50 for the purpose of receiving the spanner teeth 51 of a socket spanner 52. This nipple or bushing 46 is bored out at the opposite end and threaded as indicated at 53 and within this threaded portion is fitted the threaded end 54 of a coupling nipple 55 provided with a collar 56 adapted to butt against the end of the nipple 46 when in proper position. It will be obvious that the head 36 will be bored so that the nipple will fit therein and that it will be threaded for the reception of the threads 47. In positioning this nipple the coupling nipple 55 is removed therefrom and the nipple 46 screwed into the coupler head by means of the socket spanner 52. The coupling nipple is then screwed into the nipple 46 and the hose applied in the usual manner.

For the purpose of locking the heads together from accidental release on each of these heads there is provided a locking member or hook 57 which is pivoted as at 58 and is provided with a rearwardly extending arm 59 whereto is connected a link 60. Held beneath suitable clips 61 is a sliding plate 62 provided with a slotted opening 63 wherethrough the member 32 passes. This plate 62 is connected to the link 60 as indicated at 64 and the opposite end of the plate is provided with a lug 65 connected by means of a chain 66 to a plate 67 secured to the frame 16. By means of this construction as two of the coupling heads are brought together, the latter being so arranged as to project in forward position beyond the coupler 14, the sliding member 20 will be forced backward and the plate 62 permitted to slide forward. In order to cause this plate to slide forward each of the locking hooks 59 is provided with a notch 68 which receives one end of a spring 69 secured to

the coupling head as at 70. The tendency of this spring is normally to throw the hooks into locked position and consequently to draw the plate 62 forward. When a train is being uncoupled as soon as the pressure on the heads becomes lessened the spring 25 will expand and carry the sliding block with it. By the time the chain 66 has become tightened the couplers 14 will be entirely disengaged and the next result will be that the plate 62 will cease to move and further movement of the heads outward will serve to pull upon the links 60 and consequently to throw the hooks 57 into disengaging position as clearly indicated in Fig. 4 in full lines.

In order to provide for connection to the air line of a train certain piping is necessary. In Fig. 1 the air line will be seen as indicated at 71 and this air line is provided with the ordinary manual coupler 72 for purposes of convenience and in case of accident. At 73 is a branch pipe and in this branch pipe is a valve 74 of the ordinary type and to this valve is connected a flexible hose 75 the free end of which is connected to the hose coupling nipple 55. The valve 74 is provided with a stem 76 whereon is mounted a lever 77, the lever being connected to the stem intermediate its ends. On the car are provided suitable hangers 78 and through these hangers extend rods 79 having handles 80 and one of these rods is connected to the upper end of the lever 77 while the other rod is connected to the lower end of the same. By this means the lever may be pulled or pushed to open or closed position for the valve. In order to hold the lever in either closed or open position a locking member is provided and this locking member consists of a clamping portion 81 which fits around the branch 73 immediately above the valve and is secured thereto by means of clamp bolts 82. The locking member then branches out as indicated at 83 and terminates in stop ends 84 which are connected by a cross bar 85 having depression portions 86 formed therein. This member is so positioned that the lever 77 will lie in one of the depressions 86 when in open position and in the other depression 86 when in closed position.

The operation of the device having been described in detail throughout the specification it is not deemed necessary here to go into a detail description of the operation a second time.

There has thus been provided a simple and efficient device of the kind described and for the purpose specified.

Having thus described the invention, what is claimed as new, is:—

1. The combination with a draw bar; of a frame fixed to said draw bar, a sliding member carried on said frame, one mem-

ber of the frame acting as a stop for said sliding member, and a spring carried by said frame to permit the movement of said sliding member in the opposite direction, an air hose coupling having one end thereof pivoted to said sliding member to swing in a vertical plane, and a resilient support for the opposite end of said coupling device.

2. The combination with a draw bar and its carry iron; of a frame fixed to said draw bar of inverted U-shape, a sliding member supported on said frame and normally bearing against one of the arms of the U, a spring supported between the other arm and said sliding member to permit the member to move toward the last mentioned arm, an air hose coupling device having one end pivoted to said sliding member, and a resilient support for the opposite end of said air hose coupling device comprising a pair of chains depending from said carry iron, a yoke connecting the lower ends of said chains, a fork bolt passing through said coupling device, a collar secured upon the lower end of said fork bolt, a bolt connecting said fork bolt and yoke, and a spring held between said collar and the under side of said coupling device.

3. The combination with a draw bar; of a frame fixed to said draw bar, and an air hose coupling device supported to slide on said frame, a latch on said coupling device adapted to engage a similar latch on a similar coupling device, and an operative connection between said latch and frame to open the latch as the coupling device is moved forward.

4. The combination with a draw bar; of a frame fixed to said draw bar, and an air hose coupling device supported to slide on said frame, a latch on said coupling device adapted to engage a similar latch on a similar coupling device, an operative connection between said latch and frame to open the latch as the coupling device is moved forward, and a spring to close said latch as the coupling device is moved backward.

5. A coupling head having an inclined forward face and being provided with a guide recess having a flat inner wall perpendicular to said face and inclined outer and top and bottom walls, said coupler head further having an opening leading from the recess through the back, and a vertically tapered guide plate extending perpendicularly from the face of the coupler head provided with a guide finger extending therefrom, said plate being adapted to engage the recess and opening of an opposed coupler, and an air pipe extending through said head.

6. A coupling head having an inclined forward face and being provided with a guide recess having a flat inner wall per-

pendicular to said face and inclined outer
 and top and bottom walls, said coupler head
 further having an opening leading from
 the recess through the back, and a vertically
 5 tapered guide plate extending perpendicu-
 larly from the face of the coupler head pro-
 vided with a guide finger extending there-
 from, said plate being adapted to engage
 the recess and opening of an opposed coup-
 10 ler, an air pipe extending through said head,

a draw bar, and a flexible and yieldable
 connection between said draw bar and said
 coupler head.

In testimony whereof, I affix my signa-
 ture, in presence of two witnesses.

ARCHER H. HARRISON.

Witnesses:

M. B. MARTIN,
 J. D. BROWN.