

Dec. 23, 1958

H. R. SCOTT ET AL

2,865,136

BORDER BLOCK

Filed May 4, 1956

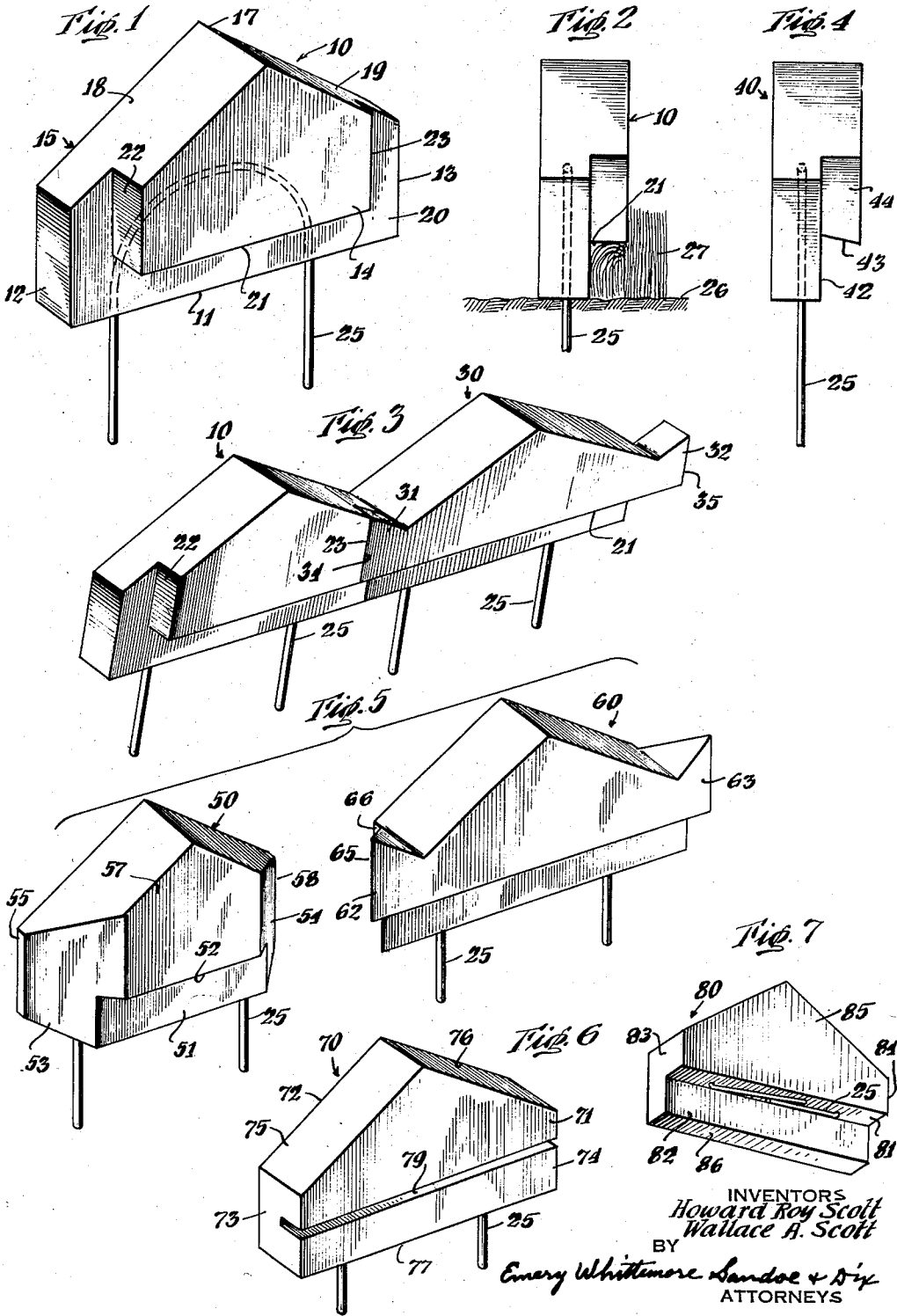

INVENTORS
Howard Roy Scott
Wallace H. Scott
BY
Emery Whittemore Sandoe & Dix
ATTORNEYS

1

2,865,136

BORDER BLOCK

Howard Roy Scott and Wallace A. Scott, Tampa, Fla.

Application May 4, 1956, Serial No. 582,676

1 Claim. (Cl. 47—33)

This invention has to do with an improved construction of a series of blocks particularly adapted to be placed end to end to form a border around a garden or around a flower bed or along a walk to definitely outline a particular area.

Also, this invention relates in general to blocks constructed of masonry, metal alloys and the like, and more particularly, to blocks which are used to provide protective edges for cultivated areas of land.

Relatively small border blocks of varying shapes have been produced to be placed around the perimeter of a flower bed, or other areas to be protected, and are well-known in the art. Blocks whose sides first rise perpendicularly to the base, then extend inwardly to form an apex, are somewhat commonplace. However, blocks of that type usually fail to provide the necessary protection when subjected to unusual pressures of wind, storm, water flowing at excessive speeds, or other external forces. As such blocks ordinarily are not deeply imbedded in the ground for economy reasons, they can be dislodged with moderate ease. Grass growing between such blocks can often times push the blocks out of line, or grass growing over them, and destroy their effectiveness as a good decorative border.

The present invention reveals several embodiments of a border block, many of which combine features which tend to firmly anchor the block in the ground, prevent grass from growing between adjacent blocks, and deflect grass away from the block when it is used to edge a lawn.

One of the features of this invention is to provide a plurality of assembled blocks interengaging each other; one set of blocks having cut away portions and another set of blocks having tongues for engaging said cut away portions of the first set of blocks, to thereby provide firm interlocking of the blocks.

Another desirable feature of this invention is the provision of an improved border block that is provided in different forms or constructions to meet preferred uses, and to include a satisfactory gripping or holding means that functions to maintain the block in its assembled and preferably, interlocked relation.

The assisting anchoring feature of the present invention is embodied in a kind of wicket form, which may suitably be composed of an aluminum alloy, or other non-corrosive alloy, and is partially embedded within the block. The protruding prongs of the wicket are inserted in the ground, and give good firm anchoring. A means of preventing grass from growing between adjacent blocks is provided by a series of interlocks that also serve to unite a group of blocks into a rigid structure. The means for deflecting growing grass may consist either of undercuts or slots within the blocks, or of separate, deflecting inserts which can be attached to the blocks. As the blocks are formed by a molding process, it is a comparatively simple matter to effect structural changes, such as slots, undercuts and interlocks, by varying the molds.

It is an object of this invention to provide border blocks which will be able to be firmly anchored in the ground by

2

means embedded within and extending beyond the plane of the blocks, or by means sunk in the ground and have protruding elements which will receive the blocks by interengaging with them or which will pinch the blocks.

5 It is also a feature of this invention to provide border blocks in which adjacent blocks will interlock and present a more or less unitary appearance.

10 It is a still further feature of this invention to provide border blocks which incorporate means for deflecting or choking off grass which grows in close proximity to the blocks.

15 It is a further object of this invention to provide for a series of simple, economical border blocks which will efficiently protect lawns, gardens and the like, and create an attractive border along a walk, around a flower bed, or around portions of a garden.

20 These and other objects and features of advantage of the present invention will become more apparent when taken in connection with the accompanying drawings, in which:

Fig. 1 is a perspective view of a block having some of its parts cut away to provide for interengaging with other blocks;

25 Fig. 2 is a side view of the block of Fig. 1, illustrating the grass-deflecting action;

30 Fig. 3 is a perspective view of the block of Fig. 1 in interlocked position with another block;

Fig. 4 is a side view of an alternative structure of the basic form of block shown in Fig. 1;

35 Fig. 5 is an exploded view in perspective of two blocks showing a modified form of the invention;

Fig. 6 is a perspective view of another modification of the invention; and

40 Fig. 7 is a perspective view of another modification of the invention.

Referring to Fig. 1, a preferred basic form of the invention comprises a block 10 having a base 11, and opposite parallel plane end surfaces 12 and 13, and opposite parallel, plane side surfaces 14 and 15, and plane diagonal surfaces 18 and 19, which extend inwardly from the end surfaces 12 and 13. These diagonal surfaces 18 and 19 intersect to form the apex 17. A portion of one of the side surfaces 14 is undercut to form an indented surface 20 and three additional surfaces. These additional surfaces correspond to base 11 and end surfaces 12 and 13. They are designated as secondary base 21, which is parallel to base 11, and secondary end surfaces 22 and 23, which are parallel to end surfaces 12 and 13 and to each other.

45 It is desired that these blocks be anchored in their assembled positions, and any suitable and effective anchoring means may be provided. In any preferred type of anchoring means employed, it is desired to have an interengagement that is effective and will continue for a goodly period of time. The preferred anchoring means herein disclosed is the wicket 25 having part of it embedded within the block 10 and part extending outwardly in the form of legs or prongs.

50 Wicket 25 may be composed of any ductile material capable of resistance to pressure and wear, but a preferable metallic alloy, such as an aluminum alloy, has usually been found desirable. As best seen in Fig. 2, the two prongs or legs which form the ends of wicket 25, are, in use, imbedded in the ground 26 or other retaining material. There is also illustrated in Fig. 2 the use of the secondary base 21 as a deflector for the grass 27, which grows in normal, vertical fashion until it reaches secondary base 21, where it is deflected away from the block 10.

70 A modified form of block 40 is illustrated in Fig. 4 and is similar to block 10, with the exception that the angle between the indented surface 20 and the secondary

base 21 is 90 degrees in block 10, and in block 40 the angle between the indented surface 42 and secondary base 43 is less than 90 degrees. This causes secondary end surface 44 of block 40 to be elongated at one end, whereas corresponding secondary end surface 22 of block 10 is rectangular. The diminution of the 90 degree angle between the indented surface 20 and the secondary base 21 in block 10 results in a greater grass-deflecting ability in block 40. The surface (not shown) opposite secondary end surface 44 of block 40 and corresponding to secondary end surface 23 of block 10 is coincident with secondary end surface 44. Block 40 can be interlocked with a block similar to block 30, but the same acute angle formed in block 40 between the secondary base 43 and the indented surface 42 should be contained in the block 30.

In Fig. 3 there is shown the block 10 in interlocking position with an adjacent block 30. This block 30 is similar to block 10, with the exception that secondary base 21 extends the entire distance from side 12 to side 13, and extensions 31 and 32 proceed outward to interengage with secondary side surfaces 22 and 23 of block 10. Extension 31 is so formed that, in interlocked position, its end surface 34 is contiguous with secondary side surface 23 of block 10 and the other surfaces of extension 31 become continuations of diagonal surface 19, side surface 14 and secondary base 21. Extension 32 of block 30 is coincident with extension 31. In Fig. 3, the extension 32 is illustrated in non-interlocking position. Block 30, similar to block 10, retains wicket 25 for securing purposes.

Another modification of the basic form of the invention is manifested in Fig. 5, where block 50 and interengaging block 60 are illustrated in exploded positions. Block 50 is similar to block 10, shown in Figs. 1, 2 and 3, but in this block 50 the height of the indented surface 51 is limited by the plane of the secondary base 52, and intersecting surfaces 53 and 54 extending between and intersecting end surface 55 and both indented surface 51 and side surface 57 on one side, and end surface 58 and both indented surface 51 and side surface 57 on the other side. Block 60 corresponds to block 30 of Fig. 3, except that the extensions 62 and 63 of block 60 are shaped so that, in Fig. 5, extension end surface 65 and end surface 66 are contiguous with intersecting surface 54 and end surface 58, respectively, in interlocking position. Greater interlocking power is a feature of blocks 50 and 60.

Another modification is illustrated in Fig. 6 and shows a block 70. As illustrated, this block is of the usual structures without interlocking extensions, or undercut portions. This block 70 is bounded by plane side surfaces 71 and 72, plane end surfaces 73 and 74, plane diagonal surfaces 75 and 76 and a plane base 77. A longitudinal slot 79 in side surface 71 is another form of block structure which acts to choke off any grass which presses close against side surface 71. If desired, a separate, deflecting insert may be removably placed within the slot and extend outwardly somewhat so as to force any grass outwardly and downwardly.

In Fig. 7 no interlocking feature is illustrated in the block 80 but when desired may be included. In this embodiment the block 80 may be cut away as shown to produce a step-like structure rising upwardly as at 82 from the primary base 86, and then backwardly toward rear wall 85 to form secondary base 81, as shown; the primary and secondary base parts 86 and 81 and the vertical part 82 joining them, all being enclosed within the side walls 83 and 84 and the rear wall 85. For shipping purposes, the prongs or legs of wicket 25 are shown in bent position. When the block is to be inserted in the ground, the legs are pulled into vertical position. While wicket 25 of block 80 enters and leaves the block through the secondary base 81, and the wicket 25 of the other

blocks heretofore illustrated enter and leave those blocks through their respective bases, all wickets illustrated may be bent as shown in Fig. 7, providing the wickets are composed of a suitable material, such as an aluminum alloy or other adaptable material.

From the foregoing description, it will be particularly noted that a very satisfactory series of blocks is provided and that each block functions to keep the grass from extending upwardly and around one of the sides of the block to too large an extent. Also, it will be particularly noted that the forms of these blocks may be readily changed so that the adjacent blocks may interlock and resist removal to a very large extent.

Also, it will be understood that the exterior forms of these blocks may be considerably modified so that they may be of oblong structure, or of semi-circular in structure, or other types of forms that are particularly adaptable for special purposes and uses. However, it will be noted that it is preferred in each instance that each separate block be provided with a satisfactory anchoring means, and in this case the preferred form is a wicket which is preferably embedded in the block and has the legs or prongs extended outwardly for being forced into the ground. In the manufacture it is desirable to bend the legs or prongs so that they are up against the underside of the indented surface 81 as shown in Fig. 7, or may be against the indented surface 11, as noted in Fig. 1. This structure makes packing and shipping easier and more satisfactory. The wicket 25 has been shown to be one form of anchoring means, but other forms of anchoring may be incorporated. For instance, the wicket may be turned upside down and forced into the ground with the legs or prongs extending upwardly and then the blocks are provided with holes for receiving the legs or prongs. Still, other forms of anchoring may be incorporated, such, for instance, as a cradle mounted on legs or prongs and the blocks forced into the cradles.

Also in producing the improved structure of block herein it is understood that the blocks may be of varied color and the preferred colors at this time are gray, white, blue, red, and yellow in pastel colors. Other colors or combinations of colors may be employed when desired.

It will be readily apparent that various changes, modifications and adaptations may be made in the above embodiments of the invention without departing from the spirit of the invention. The above description of the invention will be recognized, therefore, as being merely illustrative of the invention, and the inventor desires to be limited only by the scope of the appended claim.

The invention claimed is:

A border block of the class described, having a base portion adapted to abut a supporting surface, and vertical end walls and a front wall rising from and integral with said base portion and partially enclosing the same, said base portion being cut away to form a step-like portion comprising a section rising upwardly from the said base portion and then backwardly to meet a rear wall, said backwardly extending part constituting a secondary base portion, and means on said secondary base and foldable thereagainst for anchoring said block to a supporting surface and maintaining it in position thereon.

References Cited in the file of this patent

UNITED STATES PATENTS

352,146	Oungst	Nov. 9, 1886
557,030	Schaefer	Mar. 24, 1896

FOREIGN PATENTS

12,079	Great Britain	May 27, 1898
460,051	Great Britain	Jan. 20, 1937
504,333	Great Britain	Apr. 24, 1939
341,307	Italy	June 19, 1936