

(19) World Intellectual Property Organization
International Bureau



(43) International Publication Date
4 August 2011 (04.08.2011)

PCT

(10) International Publication Number
WO 2011/092614 A1

- (51) International Patent Classification:
A61N 1/05 (2006.01) *A61M 25/01* (2006.01)
- (21) International Application Number:
PCT/IB2011/050254
- (22) International Filing Date:
20 January 2011 (20.01.2011)
- (25) Filing Language: English
- (26) Publication Language: English
- (30) Priority Data:
10151779.5 27 January 2010 (27.01.2010) EP
- (71) Applicant (for all designated States except US): **KONINKLIJKE PHILIPS ELECTRONICS N.V.** [NL/NL]; Groenewoudseweg 1, NL-5621 BA Eindhoven (NL).
- (72) Inventors; and
- (75) Inventors/Applicants (for US only): **DECRÉ, Michel, Marcel, Jose** [BE/NL]; c/o High Tech Campus Building 44, NL-5656 AE Eindhoven (NL). **PARDOEL, Michel, Gerardus** [NL/NL]; c/o High Tech Campus Building 44, NL-5656 AE Eindhoven (NL).
- (74) Agents: **KROEZE, John** et al.; High Tech Campus 44, NL-5656 AE Eindhoven (NL).
- (81) Designated States (unless otherwise indicated, for every kind of national protection available): AE, AG, AL, AM, AO, AT, AU, AZ, BA, BB, BG, BH, BR, BW, BY, BZ, CA, CH, CL, CN, CO, CR, CU, CZ, DE, DK, DM, DO, DZ, EC, EE, EG, ES, FI, GB, GD, GE, GH, GM, GT, HN, HR, HU, ID, IL, IN, IS, JP, KE, KG, KM, KN, KP, KR, KZ, LA, LC, LK, LR, LS, LT, LU, LY, MA, MD, ME, MG, MK, MN, MW, MX, MY, MZ, NA, NG, NI, NO, NZ, OM, PE, PG, PH, PL, PT, RO, RS, RU, SC, SD, SE, SG, SK, SL, SM, ST, SV, SY, TH, TJ, TM, TN, TR, TT, TZ, UA, UG, US, UZ, VC, VN, ZA, ZM, ZW.
- (84) Designated States (unless otherwise indicated, for every kind of regional protection available): ARIPO (BW, GH, GM, KE, LR, LS, MW, MZ, NA, SD, SL, SZ, TZ, UG, ZM, ZW), Eurasian (AM, AZ, BY, KG, KZ, MD, RU, TJ, TM), European (AL, AT, BE, BG, CH, CY, CZ, DE, DK, EE, ES, FI, FR, GB, GR, HR, HU, IE, IS, IT, LT, LU, LV, MC, MK, MT, NL, NO, PL, PT, RO, RS, SE, SI, SK,

[Continued on next page]

(54) Title: SYSTEM FOR MEDICAL STIMULATION COMPRISING A PROBE

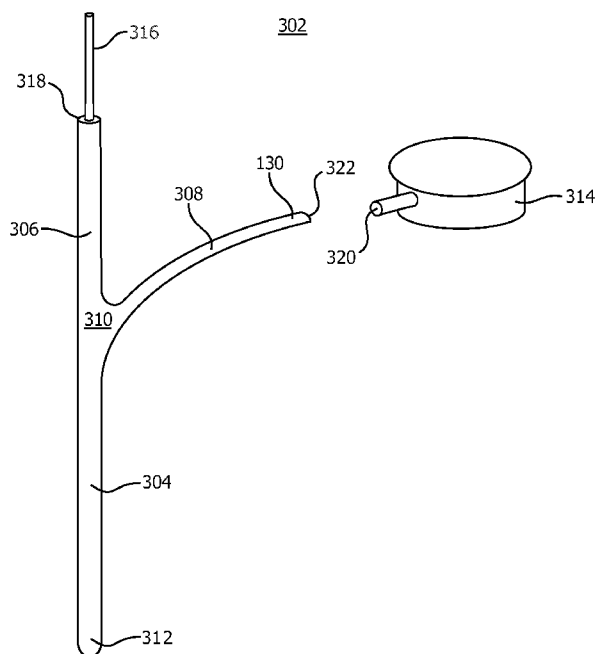

FIG. 3

(57) Abstract: The invention relates a system (302) for medical stimulation. The system (302) comprises an implantable probe (304) bifurcated into a primary branch (306) and a secondary branch (308) at a bifurcation (310), wherein the probe is provided at its distal end (112, 312) with an electrode (114) for delivering electrical stimulation to tissue. Herein, the primary branch (306) is configured for at least temporarily mechanically co-operating with a guide wire (316) configured for guiding the probe (304) into said tissue whereas the secondary branch (308) is configured for electrically connecting said electrode to a device for generating the electrical stimulation.

WO 2011/092614 A1

SM, TR), OAPI (BF, BJ, CF, CG, CI, CM, GA, GN, GQ, **Published:**
GW, ML, MR, NE, SN, TD, TG).

— *with international search report (Art. 21(3))*

Declarations under Rule 4.17:

- *as to applicant's entitlement to apply for and be granted a patent (Rule 4.17(ii))*

System for medical stimulation comprising a probe

FIELD OF THE INVENTION

The invention relates to a system for medical stimulation.

BACKGROUND OF THE INVENTION

5 Systems for neurostimulation have been used over the past ten years to treat acute or chronic neurological conditions. Such systems comprise a probe having a cylindrically shaped geometry and provided with an electrode situated in the distal end of the probe for delivering electrical pulses to a target tissue. The electrical pulses are generated by a pulse generator not situated in the probe. Therefore an electrical connection extending from
10 the proximal end of the probe is to be established between the electrode and the pulse generator. The probe is guided into the target tissue using a guide wire fitting into the probe and thereby temporarily providing mechanical stiffness to said probe.

A problem of the aforementioned method is that the receiving of the guide wire by the probe complicates the electrical connection extending from the probe to be
15 established before implanting the probe, i.e. before removing the guide wire from the probe, thereby impeding the application of a pre-manufactured electrical connection.

SUMMARY OF THE INVENTION

It is an object of the invention to provide a probe comprising an electrode for
20 delivering medical stimulation and arranged for mechanical co-operation with a guide wire, while allowing for electrically connecting the electrode situated in the probe to a device for generating the medical stimulation before implanting the probe.

This object is achieved by the system according to the invention, which system comprises an implantable probe bifurcated into a primary branch and a secondary branch at a
25 bifurcation, wherein the probe is provided at its distal end with an electrode for delivering electrical stimulation to tissue, wherein the primary branch is configured for at least temporarily mechanically co-operating with a guide wire configured for guiding the probe into said tissue, and wherein the secondary branch is configured for electrically connecting said electrode to a device for generating the electrical stimulation.

The bifurcation of the probe into a primary branch and a secondary branch, wherein the primary branch is arranged for at least temporarily mechanically co-operating with a guide wire and wherein the secondary branch is configured for mutually electrically connecting the electrode and a pulse generator, a spatial separation is effectuated between otherwise spatially conflicting functionalities of the probe. That is, the mechanical co-operation with the guide wire, which co-operation is to provide temporary mechanical resistance against buckling and bending, is spatially separated from any arrangements for electrically connecting the electrode and the pulse generator. Therefore, the co-operation between the probe and the guide wire is not impeded by any arrangement for electrically connecting the electrode to the device which is configured for generating the medical stimulation.

In this text buckling implies the sudden inability of a structural member, e.g. a probe, to withstand a compressive load as a result of the compressive load exceeding some critical level.

In this text, temporarily mechanically co-operating with a guide wire implies mechanical interaction with the guide wire on a temporary basis, e.g. by being removably attached to the guide wire or by releasably accommodating said guide wire.

As aforementioned, by having the secondary branch configured for mutually electrically connecting the electrode and the device for generating the medical stimulation, the system according to the invention advantageously avoids the need of establishing an electrical connection afterwards, i.e. after implementing the probe into a skull. The latter quality will prove particularly advantageous if the size of electrodes decreases and the number of electrodes accordingly increases as to provide more accurate stimulation of a target tissue.

Because the primary branch is configured for mechanically-co-operating with a guide wire as to provide sufficient mechanical stiffness for accurately guiding the probe into the tissue, the system according to the invention advantageously allows the probe to have significantly small mechanical resistance against bending and buckling as to conform to the tissue's geometry thereby preventing the tissue from being damaged after the guide wire's removal.

The bifurcation is mechanically well defined and allows for reinforcing in order to prevent from accidental rupture of either branch from the probe.

The probe may be manufactured from a polymer employing methods known per se, e.g. casting or injection molding of the polymer in an appropriate mold.

In a preferred embodiment of the system according to the invention, the primary branch is provided at its proximal end with an aperture for receiving the guide wire in a canal configured for accommodating said guide wire. This embodiment has the advantage that it prevents the tissue from being damaged by the possibly sharply contoured guide wire.

In a further preferred embodiment of the system according to the invention, the canal extends into the probe beyond the bifurcation. This embodiment advantageously reduces the damage potentially caused by the probe to the tissue after being implanted in said tissue since the mechanical stiffness of the probe is reduced, whereas it simultaneously increases the maneuverability of the probe by a guide wire for the purpose of accurately implanting the probe.

In a further preferred embodiment of the system according to the invention, the system comprises an electrical wire spiraling around the canal for mutually electrically connecting the electrode and the device for generating the medical stimulation. This embodiment is advantageous in that it effectively enables the integration of a relatively flat hence relatively wide electrical wire into the probe that generally has no such flat or wide geometry.

In a further preferred embodiment of the system according to the invention, the canal is closable. This embodiment advantageously prevents bodily fluids or infectious micro-organisms from entering the probe. It is to be noted that the process of closing the primary branch is largely facilitated by the branched geometry of the probe as the electrical connection between the electrode and the pulse generator does not interfere with the primary branch.

In a further preferred embodiment of the system according to the invention, the canal is closable by a blocking material injectable into the aperture. This embodiment is advantageous in that it minimizes forces exerted on the primary branch during the process of closing the aperture, thereby avoiding presumable damage of the tissue in which the probe is implantable.

In a practical embodiment of the system according to the invention, the canal is closable by a plug installable in the aperture.

In a further preferred embodiment of the system according to the invention, the primary branch is configured for being ligatured for closing the aperture. This embodiment advantageously allows for easily re-opening the canal, which re-opening may be necessary in case of malfunctioning if any.

In a further preferred embodiment of the system according to the invention, a distance between a proximal end of the secondary branch and the bifurcation is substantially larger than a distance between the proximal end of the primary branch and said bifurcation. This embodiment has the advantage of enabling optimal placement for both the probe and the
5 box as the secondary branch has sufficient length available for implanting the box at any desired position with respect to the probe.

In a further practical embodiment of the system according to the invention, the device for generating the medical stimulation is installable in an implantable box.

In a further preferred embodiment of the system according to the invention,
10 the box comprises an electrical connector for releasably electrically co-operating with a further electrical connector situated at the proximal end of the secondary branch. This embodiment has the advantage of increasing the surgical maneuverability of the probe as the implantable box may be attached and implanted afterwards.

15 SHORT DESCRIPTION OF THE FIGURES

Figure 1 schematically displays a three-dimensional image of an embodiment of the system according to the invention.

Figure 2 schematically depicts a cross-sectional image of the embodiment depicted in Figure 1.

20 Figure 3 schematically shows a three-dimensional image of an embodiment of the system according to the invention wherein the primary branch is provided with a canal for temporarily accommodating a guide wire.

Figure 4 schematically depicts an electrical wire spiraling around the canal of the probe depicted in Figure 3.

25 Figure 5 schematically shows a probe provided with a canal closable by a blocking material.

Figure 6 schematically depicts a probe having a canal closable by a plug.

Figure 7 schematically displays a probe wherein its primary branch is configured for being ligatured as to close the canal situated in the probe.

30 DETAILED DESCRIPTION OF THE EMBODIMENTS

Figure 1 schematically displays a system 102 for medical stimulation of a tissue for the therapy of acute or chronic neurological conditions in e.g. the brain or the spine. The system 102 comprises an implantable probe 104 which is bifurcated into a primary

branch 106 and a secondary branch 108 at a bifurcation 110. The probe is manufactured from polymers known per se e.g. silicone. Referring to Figure 2, the probe 104 comprises at its distal end 112 an electrode 114 for delivering medical stimulation, which medical stimulation is generated during operational conditions by a device 116, which device 116 is optionally
5 comprised in the system 102. The medical stimulation for instance encompasses a series of electrical pulses. For the purpose of generating electrical pulses, the device 116 comprises a pulse generator. Referring to Figure 1, the primary branch 104 is configured for temporarily co-operating with a guide wire 118. Referring to Figure 2 once more, in this particular embodiment the primary branch 106 is provided at its proximal end 120 with an aperture 122
10 for the purpose of receiving the guide wire 118 in a canal 124, which canal 124 is configured for at least temporarily accommodating the guide wire 118. In this particular example, the canal 124 extends into the probe 104 beyond the bifurcation point 110. The secondary branch 108 is configured for electrically connecting the electrode 114 to the device 116 for generating the medical stimulation, e.g. via an electrical wire 126. The electrical wire 126 is
15 not restricted to the geometry displayed in Figure 1; the electrical wire 126 may for instance be integrated into the probe 104 by way of a geometry spiraling around the canal 124. In this particular embodiment, the device 116 is installable in an implantable box 128, which box 128 may be attached to a proximal end 130 of the secondary branch 108. Alternatively, the box 128 may be provided with an electrical connector (not depicted) for releasably co-
20 operating with a further electrical connector (not depicted) situated at the proximal end 130 of the secondary branch 108. In this specific example the distance L_2 between the proximal end 130 of the secondary branch 108 and the bifurcation 110, is significantly larger than the distance L_1 between the proximal end 120 of the primary branch 106 and said bifurcation 110.

25 Figure 3 schematically depicts a system 302 for medical stimulation of tissue. The system 302 comprises an implantable probe 304 which is bifurcated into a primary branch 306 and a secondary branch 308 at a bifurcation 310. The probe 304 comprises at its distal end 312 an electrode (not shown) for delivering said medical stimulation to the tissue e.g. by way of electrical pulses. The medical stimulation is generated during operational
30 conditions by a device (not shown) known per se and optionally comprised in the system 302. Said device is facultatively situated in an implantable box 314. The primary branch 304 is configured for temporarily co-operating with a guide wire 316. In this particular embodiment the primary branch 306 is provided at its proximal end 318 with an aperture 315 for the purpose of receiving the guide wire 316 in a canal 317, see Figure 4, which canal 317 is

configured for at least temporarily accommodating the guide wire 316. The canal optionally extends into the probe 304 beyond the bifurcation point 310. Referring to Figure 3, the secondary branch 308 is configured for electrically connecting the electrode and the device optionally comprised in the system 302. Herein, for the purpose of releasably electrically connecting the electrode to the device situated in the box 314, the box 314 is provided with an electrical connector 320 configured for releasably co-operating with a further electrical connector (not shown) situated at a proximal end 322 of the secondary branch 308. Referring to Figure 4, the secondary branch 308 accommodates an electrical wire 324 for electrically connecting the electrode to the further electrical connector. The electrical wire 324 is incorporated in the probe 304 in a geometry spiraling around the canal 317.

Figure 5 schematically depicts a probe 502 bifurcated in a primary branch 504 and a secondary branch 506 at a bifurcation 508, wherein the primary branch 504 is provided with a canal 510 for temporarily accommodating a guide wire (not shown). The canal 510 is closable by way of a blocking material 512 which is injectable into the canal 510. The blocking material 512 may be manufactured from e.g. silicone or biocompatible glue. Referring to Figures 1 and 3, the canals 124 and 317 allow for similar closure, respectively.

Figure 6 schematically depicts a probe 602 bifurcated in a primary branch 604 and a secondary branch (not shown), wherein the primary branch 604 is provided with a canal 606 for at least temporarily mechanically co-operating with a guide wire (not shown). The canal 606 is closable by way of a plug 608 installable in the canal 606. Referring to Figures 1 and 3, the canals 124 and 317 allow for similar closure, respectively.

Figure 7 schematically depicts a probe 702 bifurcated in a primary branch 704 and a secondary branch (not shown), wherein the primary branch 704 is provided with a canal 706 for at least temporarily accommodating a guide wire (not shown). The canal 706 is configured for being ligatured e.g. by way of a surgical thread 708. Referring to Figures 1 and 3, the canals 124 and 317 allow for similar closure, respectively.

While the invention has been illustrated and described in detail in the drawings and in the foregoing description, the illustrations and the description are to be considered illustrative or exemplary and not restrictive. The invention is not limited to the disclosed embodiments. It is noted that the system according to the invention and all its components can be made by applying processes and materials known per se. In the set of claims and the description the word “comprising” does not exclude other elements and the indefinite article “a” or “an” does not exclude a plurality. Any reference signs in the claims should not be

construed as limiting the scope. It is further noted that all possible combinations of features as defined in the set of claims are part of the invention.

CLAIMS:

1. A system (102, 302) for medical stimulation, comprising an implantable probe (104, 304, 502, 602, 702) bifurcated into a primary branch (106, 306, 504, 604, 704) and a secondary branch (108, 308, 506) at a bifurcation (110, 310, 508), wherein the probe is provided at its distal end (112, 312) with an electrode (114) for delivering electrical
5 stimulation to tissue, wherein the primary branch is configured for at least temporarily mechanically co-operating with a guide wire (118, 316) configured for guiding the probe into said tissue, and wherein the secondary branch is configured for electrically connecting said electrode to a device (116) for generating the electrical stimulation.
- 10 2. The system according to claim 1, wherein the primary branch is provided at its proximal end (120, 318) with an aperture (122, 315) for receiving the guide wire in a canal (124, 317) configured for accommodating said guide wire.
3. The system according to claim 2, wherein the canal (124) extends beyond the
15 bifurcation (110).
4. The system according to claim 2, comprising an electrical wire (324) spiraling around the canal (317) for electrically connecting the electrode to the device (116).
- 20 5. The system according to claim 2, wherein the canal (124, 317, 508, 606, 706) is closable.
6. The system according to claim 2 wherein the canal (510) is closable by a blocking material (512) injectable in the aperture.
25
7. The system according to claim 2 wherein the canal (606) is closable by a plug (608) installable in the aperture.

8. The system according to claim 2 wherein the primary branch (604) is configured for being ligatured for closing the aperture.

9. The system according to claim 1, wherein a distance (L_2) between a proximal end (130) of the secondary branch (108) and the bifurcation (110) is substantially larger than a distance (L_1) between the proximal end (120) of the primary branch (106) and the bifurcation.

10. The system according to claim 1, wherein the device (116) is installable in an implantable box (128, 314).

11. The system according to claim 10, wherein the box comprises an electrical connector (320) for releasably electrically co-operating with a further electrical connector situated at a proximal end (322) of the secondary branch (308).

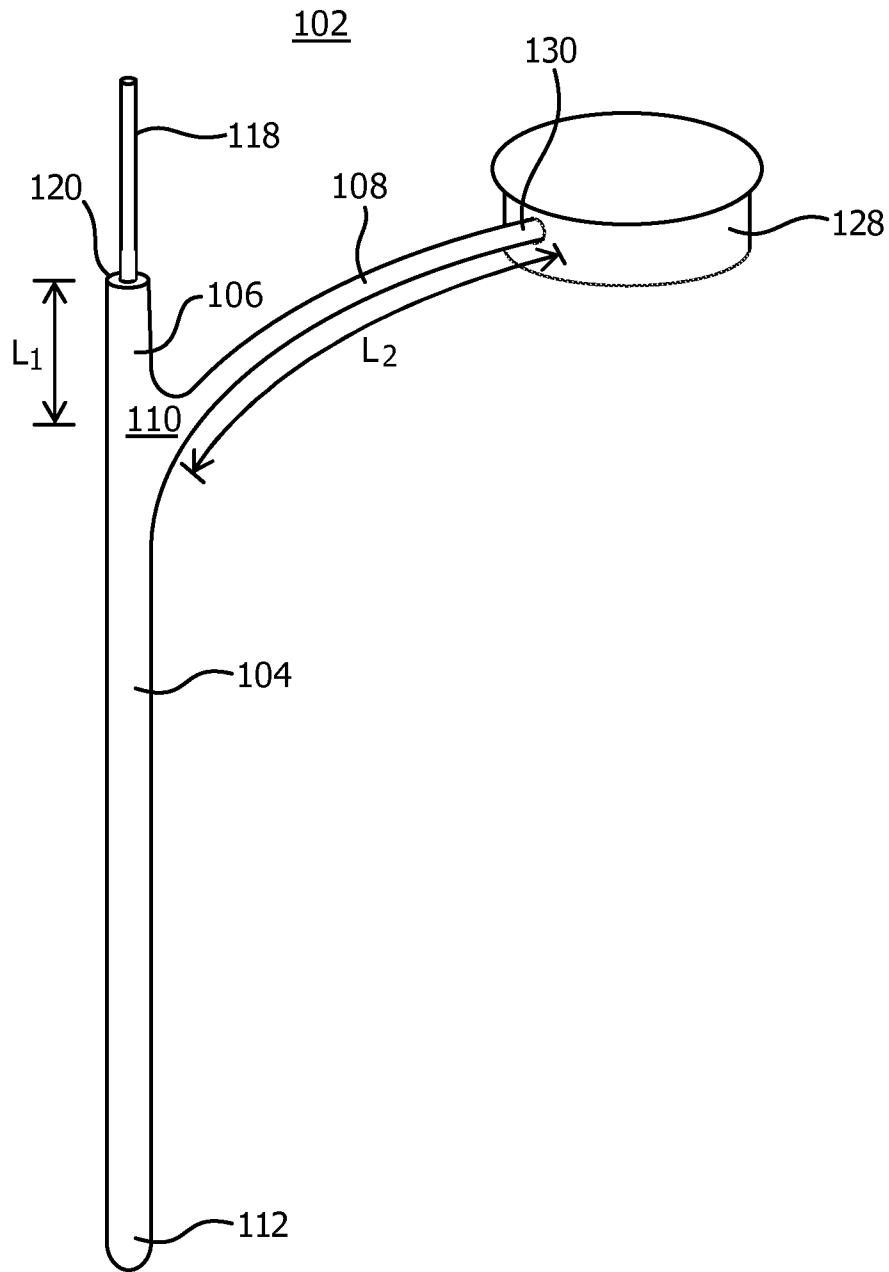

FIG. 1

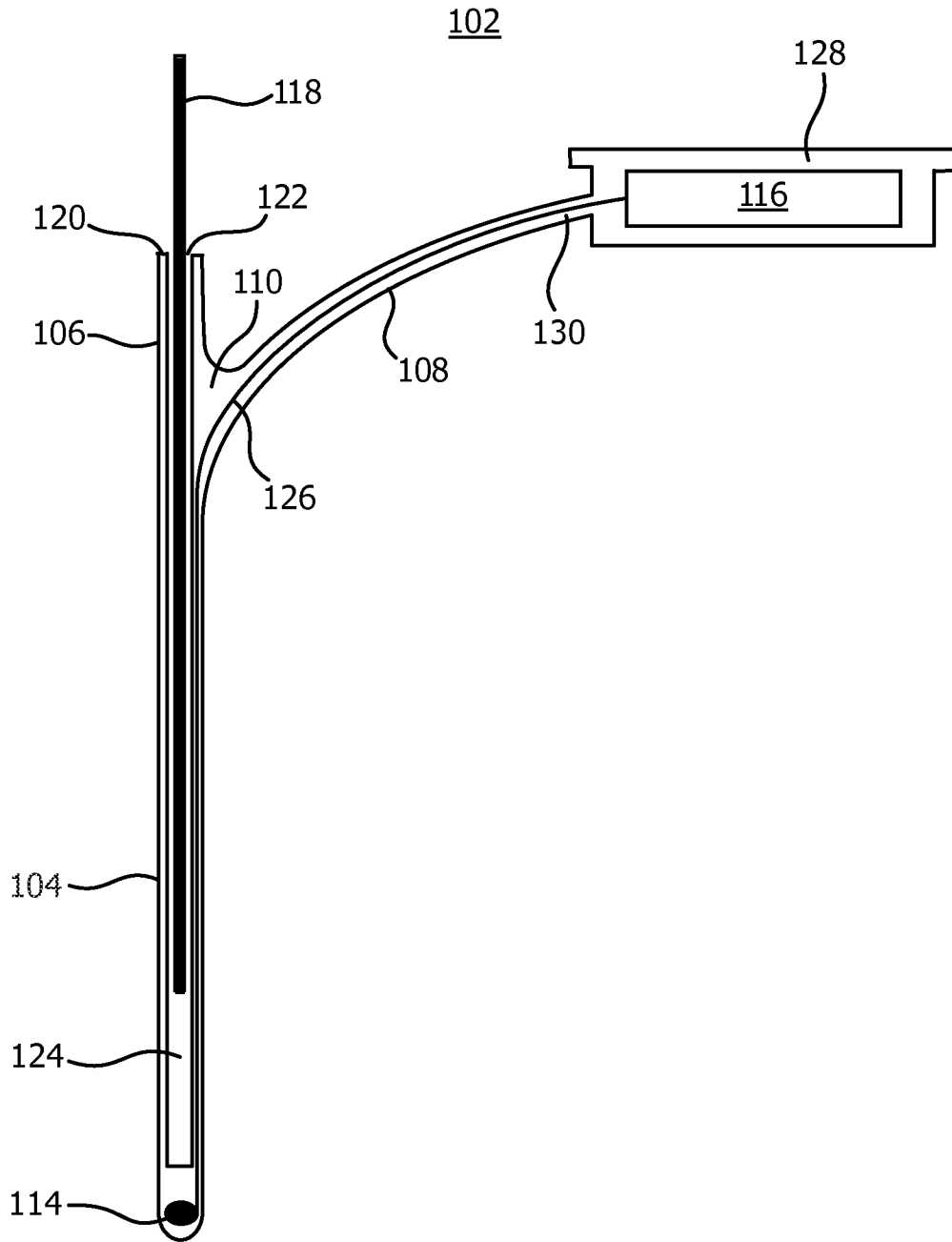

FIG. 2

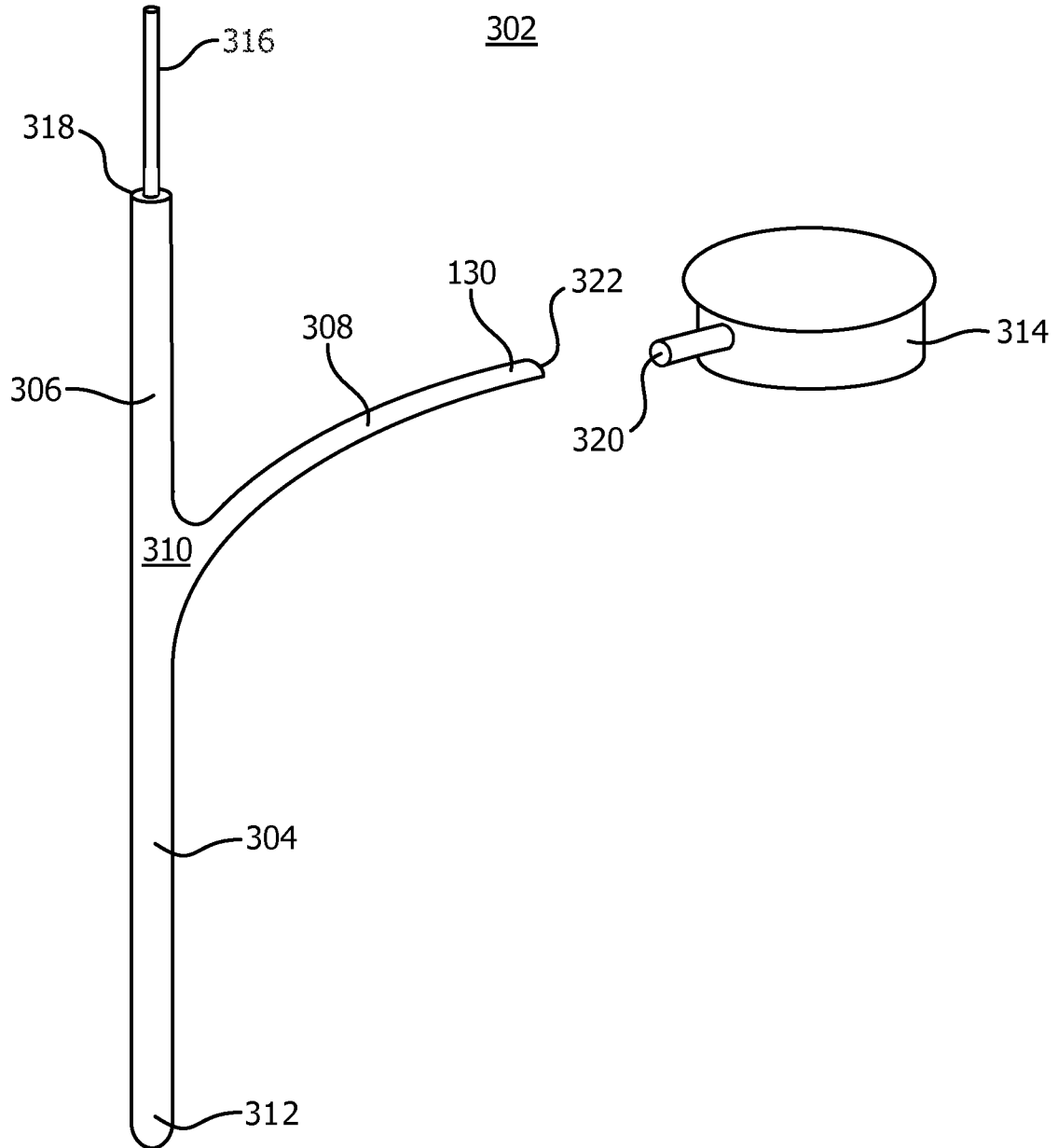

FIG. 3

4/5

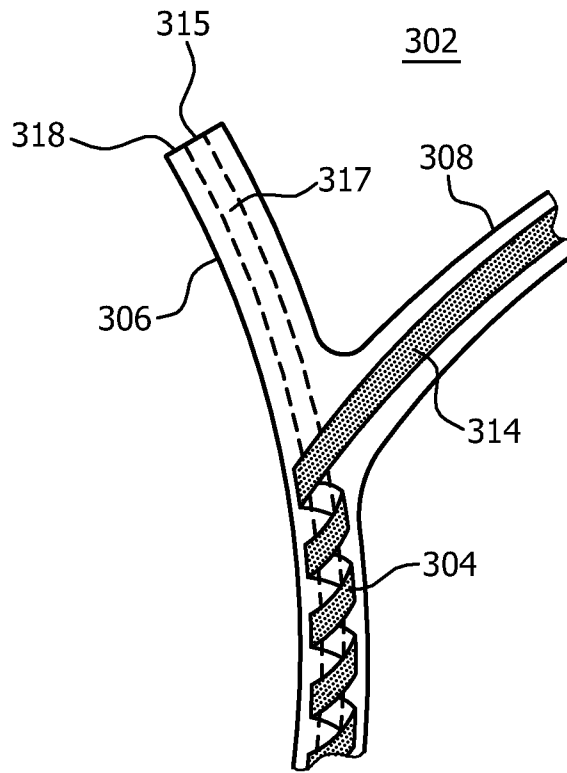

FIG. 4

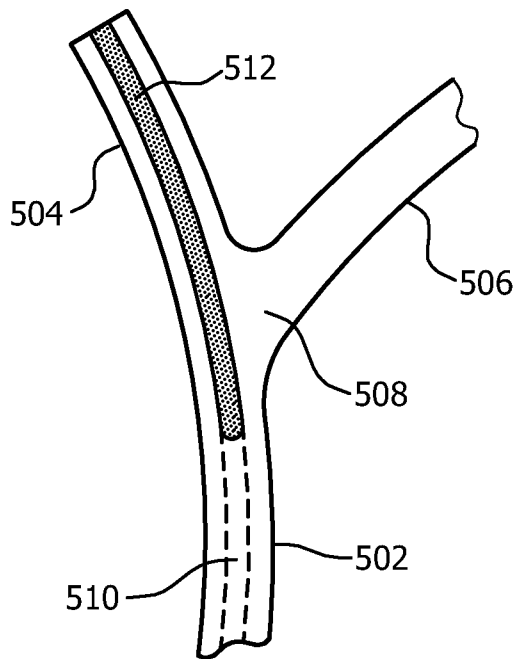

FIG. 5

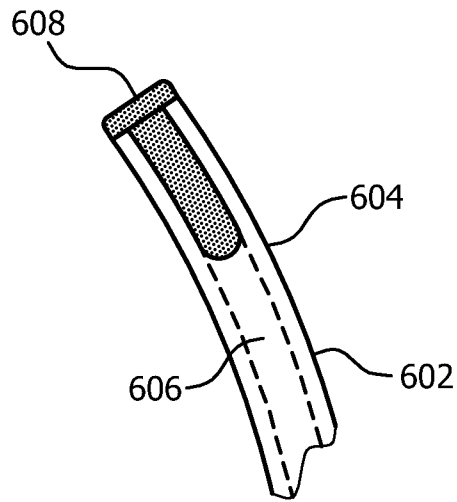

FIG. 6

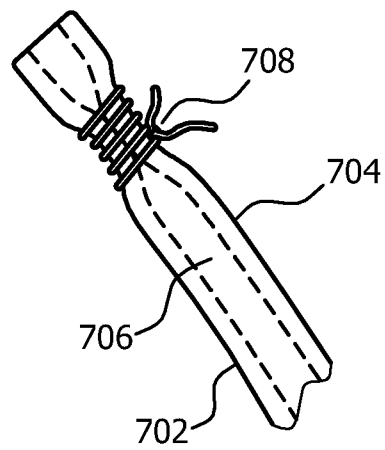

FIG. 7

INTERNATIONAL SEARCH REPORT

International application No
PCT/IB2011/050254

A. CLASSIFICATION OF SUBJECT MATTER
INV. A61N1/05
ADD. A61M25/01

According to International Patent Classification (IPC) or to both national classification and IPC

B. FIELDS SEARCHED

Minimum documentation searched (classification system followed by classification symbols)
A61N

Documentation searched other than minimum documentation to the extent that such documents are included in the fields searched

Electronic data base consulted during the international search (name of data base and, where practical, search terms used)
EPO-Internal, WPI Data

C. DOCUMENTS CONSIDERED TO BE RELEVANT		
Category*	Citation of document, with indication, where appropriate, of the relevant passages	Relevant to claim No.
X	US 2008/208306 A1 (RUTTEN JEAN J G [NL]) 28 August 2008 (2008-08-28) figures 1-3 paragraphs [0001] - [0002], [0016] - [0017], [0021] -----	1-3,5-11
X	WO 83/04181 A1 (MCCORKLE CHARLES E JR [US]) 8 December 1983 (1983-12-08) figures 1a-1c page 1 - pages 4-8 page 9 - page 11 -----	1-4,9-11
X	US 5 405 374 A (STEIN PAUL M [US]) 11 April 1995 (1995-04-11) figure 1 column 3 - column 4 -----	1

Further documents are listed in the continuation of Box C.

See patent family annex.

* Special categories of cited documents :

"A" document defining the general state of the art which is not considered to be of particular relevance

"E" earlier document but published on or after the international filing date

"L" document which may throw doubts on priority claim(s) or which is cited to establish the publication date of another citation or other special reason (as specified)

"O" document referring to an oral disclosure, use, exhibition or other means

"P" document published prior to the international filing date but later than the priority date claimed

"T" later document published after the international filing date or priority date and not in conflict with the application but cited to understand the principle or theory underlying the invention

"X" document of particular relevance; the claimed invention cannot be considered novel or cannot be considered to involve an inventive step when the document is taken alone

"Y" document of particular relevance; the claimed invention cannot be considered to involve an inventive step when the document is combined with one or more other such documents, such combination being obvious to a person skilled in the art.

"&" document member of the same patent family

Date of the actual completion of the international search 28 April 2011	Date of mailing of the international search report 06/05/2011
Name and mailing address of the ISA/ European Patent Office, P.B. 5818 Patentlaan 2 NL - 2280 HV Rijswijk Tel. (+31-70) 340-2040, Fax: (+31-70) 340-3016	Authorized officer Gentil, Cédric

INTERNATIONAL SEARCH REPORT

Information on patent family members

International application No

PCT/IB2011/050254

Patent document cited in search report	Publication date	Patent family member(s)	Publication date
US 2008208306	A1	28-08-2008	NONE

WO 8304181	A1	08-12-1983	AU 8685682 A 16-12-1983
		EP 0108752 A1	23-05-1984

US 5405374	A	11-04-1995	NONE
