

A. M. JOHNSON.
 CHURN OPERATING MECHANISM.
 APPLICATION FILED JAN. 23, 1909.

934,537.

Patented Sept. 21, 1909.

2 SHEETS—SHEET 1.

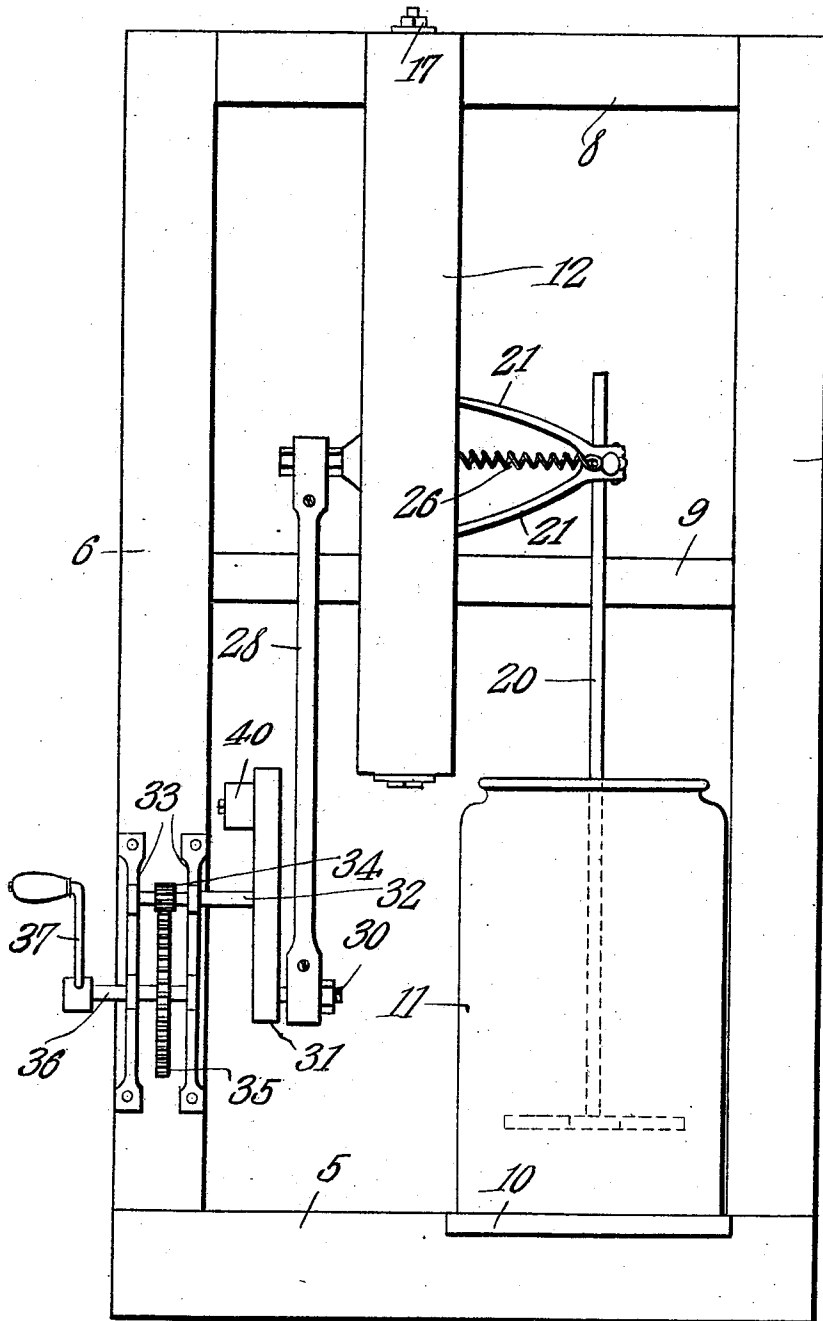

Fig. 1.

Inventor

Adolphus M. Johnson.

Witnesses

E. W. Hunt
M. A. Schmidt

By

Carroll Co.
 Attorneys

A. M. JOHNSON.
 CHURN OPERATING MECHANISM.
 APPLICATION FILED JAN. 23, 1909.

934,537.

Patented Sept. 21, 1909.
 2 SHEETS—SHEET 2.

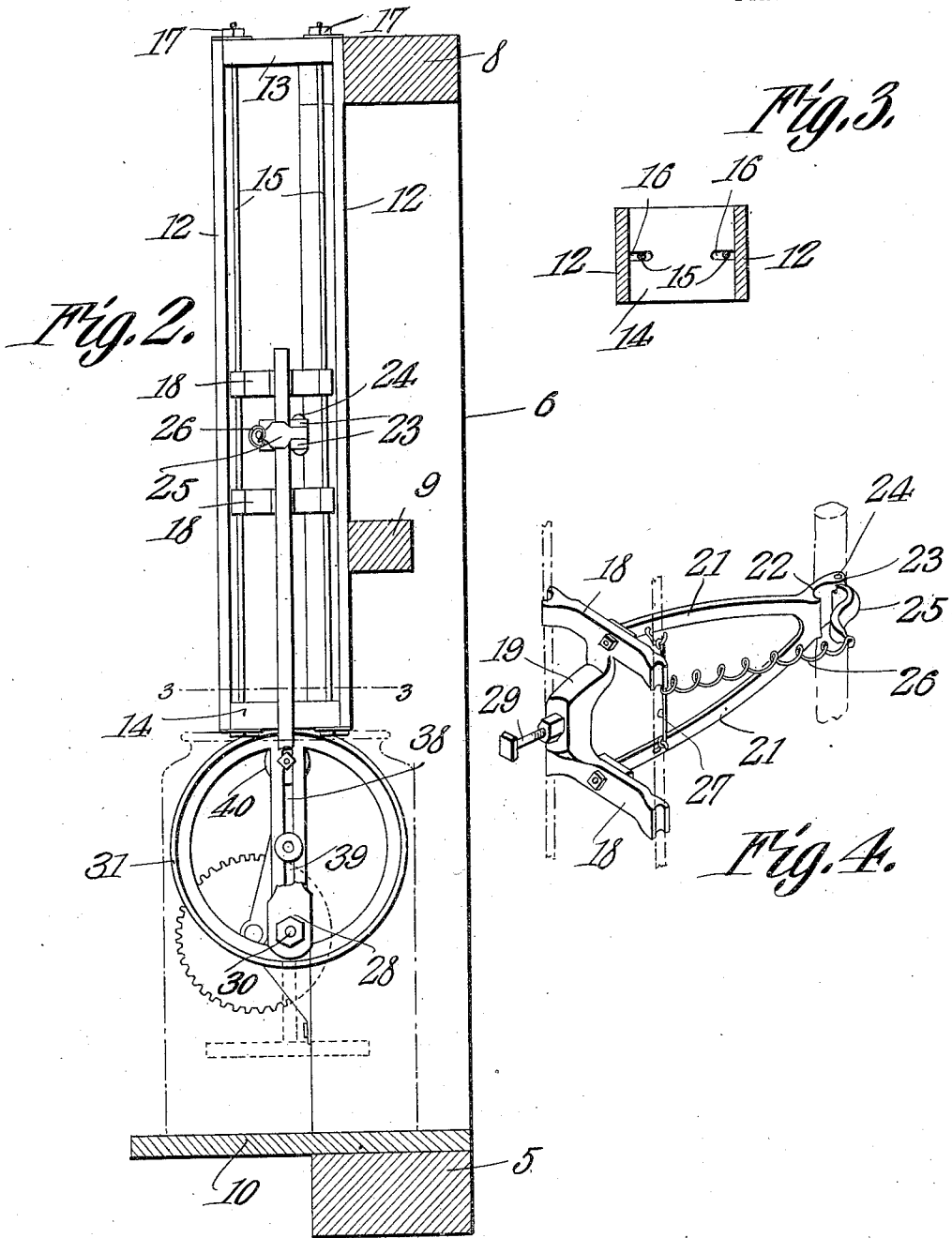

Inventor
Adolphus M. Johnson.

Witnesses

E. W. Stewart
M. Schmidt

By *Chas. H. Co.*
 Attorneys

UNITED STATES PATENT OFFICE.

ADOLPHUS MARIAN JOHNSON, OF TATE, GEORGIA.

CHURN-OPERATING MECHANISM.

934,537.

Specification of Letters Patent. Patented Sept. 21, 1909.

Application filed January 23, 1909. Serial No. 473,881.

To all whom it may concern:

Be it known that I, ADOLPHUS MARIAN JOHNSON, a citizen of the United States, residing at Tate, in the county of Pickens and State of Georgia, have invented a new and useful Churn-Operating Mechanism, of which the following is a specification.

This invention relates to operating mechanism for churns having a reciprocating dasher, and the object of the present invention is to provide a mechanism which is simple in structure and which is easily actuated.

The invention also has for its object to provide an operating mechanism which can be readily adjusted to churns of different sizes, and also to provide means for regulating the stroke of the dasher.

With the foregoing objects in view, as well as others, which will be apparent when the invention is better understood, the same consists in a novel construction and arrangement of parts, to be hereinafter described and claimed, reference being had to the drawings hereto annexed, in which:—

Figure 1 is a side elevation of the operating mechanism: Fig. 2 is a front elevation: Fig. 3 is a horizontal sectional detail on the line 3—3 of Fig. 2: Fig. 4 is a perspective detail of the cross-head.

The supporting frame of the mechanism comprises a base 5, and spaced upright end bars 6 and 7 respectively, connected by a top cross-bar 8 and an intermediate cross-bar 9. On the base is mounted a platform 10, on which the churn 11 is supported. To the cross-bars 8 and 9 is secured a frame which carries guides for the reciprocating cross-head, to be presently described, said frame comprising vertical side bars 12, and top and bottom cross-bars 13 and 14, respectively, connecting the same, whereby a rectangular frame is had, which is mounted on the supporting frame by being secured to the cross-bars 8 and 9. The cross-bars 13 and 14 are connected by the spaced rods 15, on which the cross-head slides, and whereby it is guided. Said rods pass through slots 16 in the cross-bars 13 and 14 and are fastened thereto by bolts 17. The slots permit the guide rods to be adjusted to take up wear.

The cross-head already referred to comprises a pair of spaced arms 18, which are connected by a web 19. The ends of the arms are grooved to fit the guide rods 15. The cross-head carries a bracket, provided

with means for connecting the dasher stem 20 thereto. Said bracket comprises vertically spaced arms 21, which are bolted or otherwise secured to the arms 18 intermediate the ends thereof. The arms 21 project outwardly from the arms 18 and are converged and connected at their outer ends. At the junction of the arms is a vertical groove 22 in which the dasher stem 20 is received. The terminal of the arms is also formed with hinge knuckles 23, to which is connected, by a hinge pin 24, a clamping member 25, which is engageable with the dasher stem, and serves to clamp the same in the groove 22, the member 25 being operated by a spring 26, which is connected at one end to the free end of the said member, and at the other end to a cross-bar 27, secured to the arms 21. By means of this spring-actuated clamp the dasher stem is rigidly connected to the cross-head, and, at the same time, may be readily adjusted vertically upon swinging the clamping member 25 out of engagement therewith.

The cross-head is operated by a pitman 28, which is connected at one end to a stud 29, projecting from the web 19, and at the other end to a wrist-pin 30, on a crank wheel 31. Said crank wheel is on a shaft 32, mounted in suitable bearing brackets 33, secured to the post 6, and on said shaft is a pinion 34, which meshes with a spur gear 35 on a shaft 36, also mounted in suitable bearings on the post 6. The shaft 36 is provided with a crank handle 37, for turning the same, whereby the cross-head, through the herein described gearing, is reciprocated.

On opposite sides of the center of the crank wheel 31 are radial slots 38 and 39, respectively, these slots being in alinement. The wrist-pin 30 is adjustably mounted in the slot 38, and in the slot 39 is adjustably mounted a counterweight 40. By adjusting the wrist-pin in the slot 38, the stroke of the pitman may be lengthened or shortened, to lengthen and shorten the travel of the cross-head, which regulates the stroke of the dasher, and adjustment can therefore be made according to the amount of milk in the receptacle 11, or the height thereof. The counterweight will be adjusted according to the position of the wrist-pin, and by said counterweight the mechanism is balanced and will work smoother and easier, and requires less exertion to operate the same.

What is claimed is:—

In a churn operating mechanism, a supporting frame comprising supporting bars having alined transverse slots, a pair of spaced guide rods mounted in the slots and adjustable therein with respect to each other, a cross head slidably mounted between the rods, said cross head comprising spaced arms and a web connecting the same intermediate their ends, the ends of the arms having grooves in which the guide rods fit, bracket arms secured to the arms of the cross head and projecting outwardly therefrom, said

bracket arms converging and being connected at their outer ends, and having at said ends, dasher stem supporting means, the stud projecting from the web of the cross head, and means connected to said stud for reciprocating the cross head. 15

In testimony that I claim the foregoing as my own, I have hereto affixed my signature in the presence of two witnesses. 20

ADOLPHUS MARIAN JOHNSON.

Witnesses:

R. G. HENDERSON,
ISAAC GRANT.