

(19) World Intellectual Property Organization
International Bureau



(43) International Publication Date
26 April 2001 (26.04.2001)

PCT

(10) International Publication Number
WO 01/28875 A1

- (51) International Patent Classification⁷: B65D 17/34 (74) Agent: HONG, Sung, Chul; 7th Floor New Seoul Building, 828-8 Yeoksam-dong, Kangnam-ku, Seoul 135-080 (KR).
- (21) International Application Number: PCT/KR99/00685
- (22) International Filing Date: 15 November 1999 (15.11.1999) (81) Designated States (*national*): AE, AL, AU, BA, BB, BG, BR, CA, CN, CU, CZ, EE, GD, GE, HR, HU, ID, IL, IN, IS, JP, KP, LC, LK, LR, LT, LV, MG, MK, MN, MX, NO, NZ, PL, RO, SG, SI, SK, SL, TR, TT, UA, US, UZ, VN, YU, ZA.
- (25) Filing Language: English
- (26) Publication Language: English
- (30) Priority Data: 1999/45337 19 October 1999 (19.10.1999) KR (84) Designated States (*regional*): ARIPO patent (GH, GM, KE, LS, MW, SD, SL, SZ, TZ, UG, ZW), Eurasian patent (AM, AZ, BY, KG, KZ, MD, RU, TJ, TM), European patent (AT, BE, CH, CY, DE, DK, ES, FI, FR, GB, GR, IE, IT, LU, MC, NL, PT, SE), OAPI patent (BF, BJ, CF, CG, CI, CM, GA, GN, GW, ML, MR, NE, SN, TD, TG).
- (71) Applicant (*for all designated States except US*): BONG-JEONG INDUSTRIAL CO., LTD. [KR/KR]; Wooyoung Venture Building 402, 1330-13 Seocho-dong, Seocho-ku, Seoul 137-070 (KR).
- (72) Inventors; and
- (75) Inventors/Applicants (*for US only*): CHO, Sung, Ho [KR/KR]; 312-2301 Kummaeul Apt., 933-7(14/6) Pyongchon-dong, Dongan-ku, Anyang-shi, Kyongki-do 431-070 (KR). SON, Tae, Hyun [KR/KR]; 215-17 Bijeon-dong, Pyungtaik-shi, Kyongki-do 450-150 (KR).
- Published:
— *With international search report.*
- For two-letter codes and other abbreviations, refer to the "Guidance Notes on Codes and Abbreviations" appearing at the beginning of each regular issue of the PCT Gazette.*



WO 01/28875 A1

(54) Title: A CAN OPENER CONSTRUCTION WITH BETTER EASINESS IN OPENING AND ENHANCED SANITARINESS

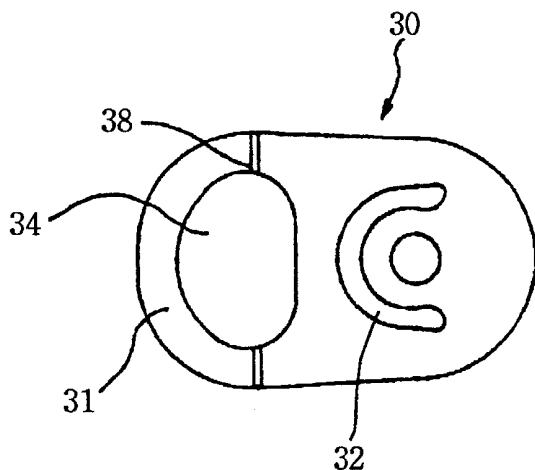

(57) Abstract: A can lid structure, with an opening tab providing improved practicability, enhanced opening function and improved sanitarness, is disclosed. This can lid structure is preferably used with easy open cans with one-touch type opening means, or with a so-called "stay-on tab". In the above can lid structure, an opening tab (30), locked to a can lid using a rivet (24), is levered up by a user so as to break the seal of an opening piece (22) along a depressed seam (21) on the can lid when it is necessary to open the lid prior to emptying a can (10). In order to open the can lid, the free end portion (31) of the tab 30 is primarily raised up from the top surface (20) of the can lid while forming an appropriate gap between the tab (30) and the can lid by pressing the tab (30) downwardly by a finger. The tab (30) is, thereafter, levered up to break the seal of the opening piece (22) along the depressed seam (21). The above object is accomplished by a thumb pushing part (36), a thumb-operable resilient bulge (33), and/or a depressed linear portion (38) in the form of a groove, respectively formed on predetermined positions of

the tab (30). This can lid structure thus accomplishes a desired sanitarness, operational convenience and operational reliability of cans (10).

-1-

A CAN OPENER CONSTRUCTION WITH BETTER EASINESS IN
OPENING AND ENHANCED SANITARINESS

Technical Field

The present invention relates, in general, to can lid
5 structures for easy open cans with one-touch type opening
means, or with a so-called "stay-on tab", and, more
particularly, to a can lid structure for such cans
designed to easily raise the outside end of an opening
10 tab from the top surface of a can lid by a finger-
pressing action, thus primarily forming an appropriate gap
between the tab and the can lid prior to levering up the
tab so as to open the can lid at an opening piece, the
tab being provided with a thumb pushing part, a thumb-
operable resilient bulge and/or a depressed groove at
15 predetermined positions, thus allowing a user to easily
raise the end portion of the tab upwardly from the can
lid and to open the can lid while accomplishing desired
sanitariness, operational convenience and operational
reliability of cans.

20 Background Art

As shown in Fig. 1, several types of can lids, with
opening tabs 30 designed to easily break the seal of an
opening piece 22 of a can 10 along a depressed seam, have
been proposed and used. For example, a conventional pull
25 type opening tab is designed to pull an opening piece
upwardly so as to break the seal of the opening piece
along a depressed seam until the opening piece is
completely removed from the can lid while forming an
opening on the can lid. Another pull type opening tab is
30 designed to pull the opening piece upwardly so as to open
the can lid without completely removing the opening piece
from the can lid. A push type opening tab is designed to
be levered up, and so the tab pushes the opening piece
into a can while breaking the seal of the opening piece
35 along a depressed seam until a desired opening is formed
on the can lid.

-2-

In addition, combined type opening tabs, each designed to be pulled upwardly so as to push the opening piece into the can while breaking the seal of the opening piece along a depressed seam, have been widely used in the prior art. Such an opening tab 30 for cans is typically made of steel or aluminum. In order to open the can lid prior to emptying a can, the tab 30, locked to the top surface 20 of the can lid using a rivet 24, is levered up, thus breaking the seal of an opening piece 22 along a depressed seam 21 of the can lid and forming a desired opening on the top surface 20 of the can lid. Therefore, it is possible for a user to empty the can through the opening formed on the can lid.

However, such a conventional can is a pressure-tight can or a vacuum sealed can, and so the can may be easily affected by a water hammering action in that the highly pressurized contents of the can undesirably pressurize the can lid when unexpected external impact is applied to the can. In the case of such a water hammering action, shearing stress is formed on the opening piece 22 defined on the can lid by the depressed seam 21 and may unexpectedly break the seal of the opening piece 22 along the depressed seam 21. Therefore, it is necessary for the depressed seam 21 to have a sufficient thickness to resist such a shearing stress caused by the water hammering action. In order to break the opening piece 22 along the depressed seam 21 and to form an opening on the can lid, it is necessary for a user to apply a substantial force to the opening piece 22 using the tab 30. Since the tab 30 comes into contact with the opening piece 22 and initially applies a breaking force to the depressed seam 21 at a time the end portion 31 of the tab 30 is raised up by a user, it is somewhat difficult to raise the end portion 31 of the tab 30 upwardly from the top surface 20 of the can lid. This forces some children or some elderly people to request a person around them to open their cans instead of them. In addition, the opening tab, closely positioned on the can lid without leaving a substantial gap between the tab and the can lid, forces a user to insert a thin material, such as a

-3-

fingernail, between the end portion 31 of the tab 30 and the can lid so as to slightly separate the end portion 31 from the top surface 20 of the can lid prior to breaking the seal of the opening piece 22 along the depressed seam 5 21 by levering up the tab 30. However, such conventional cans are very inconvenient to users while opening the can lid. That is, it is very difficult to open the can lids by operating the opening tabs 30 by fingernails of users. The conventional cans thus sometimes undesirably break the 10 nails of users or damage the fingers of users. Another disadvantage of the conventional can lid structure resides in that the opening piece 22 of the can lid may be easily contaminated with impurities, such as dust, and so the lid structure is unsanitary.

15

Disclosure of the Invention

Accordingly, the present invention has been made keeping in mind the above problems occurring in the prior art, and an object of the present invention is to provide 20 a can lid structure with an opening means providing an enhanced opening function and improved sanitarness, which is designed to easily raise the outside end of an opening tab from the top surface of a can lid by a finger-pressing action, thus primarily forming an appropriate gap 25 between the tab and the can lid prior to levering up the tab so as to open the can lid at an opening piece, the tab being also provided with a thumb pushing part, a thumb-operable resilient bulge and/or a depressed groove at predetermined positions, thus allowing a user to easily 30 raise the end portion of the tab upwardly from the can lid and to open the can lid while accomplishing desired sanitarness, operational convenience and operational reliability of cans.

The can lid structure of the present invention is 35 made to improve the can lid structures disclosed in U.S. Patent No. 5,813,559, Japanese Patent No. 2,913,279, Korean Patent No. 141,618 and Korean Patent Application No. 99-12,571, all being owned or applied by the inventor of this invention.

-4-

In order to accomplish the above object, the primary embodiment of the present invention provides a can lid structure, comprising an opening piece formed on a can lid along a depressed seam, and an opening tab exteriorly attached to the can lid using a rivet and used for breaking the seal of the opening piece along the depressed seam when necessary, wherein depressed linear portions in the form of depressed grooves are formed on the opening tab at predetermined positions. In another embodiment of this invention, a thumb pushing part or a thumb-operable resilient bulge is formed on a predetermined portion of the opening tab, thus elastically raising the free end portion of the tab from the can lid while forming an appropriate gap between the tab and the lid when the tab is pressed down by a finger at the thumb pushing part or at the thumb-operable resilient bulge.

In the present invention, a plurality of regularly spaced grooves in the form of a concentric circular profile, a linear profile or a comb structural profile may be formed on an upper or lower surface of the thumb-operable resilient bulge, thus allowing the bulge to be smoothly operated.

In a further embodiment, the opening tab is designed to have its original function as a can opening means and a collateral function as a sanitary cover for the opening piece of the can lid. In such a case, the opening tab remarkably improves the sanitariness of a can in addition to the enhanced opening function.

Brief Description of the Drawings

The above and other objects, features and other advantages of the present invention will be more clearly understood from the following detailed description taken in conjunction with the accompanying drawings, in which:

Fig. 1 is a perspective view of a can lid with an opening tab in accordance with the primary embodiment of the present invention;

Figs. 1a to 1e are plan or sectional views, showing the construction of depressed linear portions provided on

the opening tab in accordance with modifications of the primary embodiment of this invention, respectively;

5 Figs. 1f and 1g are plan and sectional views, showing a depression formed on the can lid at a position under the depressed linear portions of the opening tab in accordance with another modification of the primary embodiment of this invention;

10 Figs. 1h to 1j are plan views, showing the construction of a thumb pushing part provided on the opening tab in accordance with other modifications of the primary embodiment of this invention, respectively;

15 Figs. 1k to 1n are sectional or plan views, showing the construction of depressed linear portions formed on the opening tab in accordance with other modifications of the primary embodiment of this invention, respectively;

Figs. 1o to 1q are plan views, showing the construction of a thumb pushing part provided on the opening tab in accordance with further modifications of the primary embodiment of this invention, respectively;

20 Fig. 1r is a sectional view, showing a can lid opening operation of the opening tab according to the primary embodiment of the present invention;

25 Fig. 2 is a perspective view of a can lid with an opening tab in accordance with the second embodiment of the present invention;

30 Figs. 2a to 2c are plan or sectional views, showing the construction of regularly spaced grooves formed on the upper or lower surface of the thumb-operable resilient bulge of the opening tab in accordance with modifications of the second embodiment of this invention, respectively;

35 Figs. 2d to 2i are plan views, showing the construction of reinforcing parts provided on the thumb-operable resilient bulge of the opening tab in accordance with modifications of the second embodiment of this invention, respectively;

Figs. 2j to 2l are plan views, showing the construction of depressed linear portions formed on the opening tab in accordance with modifications of the second embodiment of this invention, respectively;

40 Figs. 2m to 2o are sectional or plan views, showing

-6-

the construction of depressed linear portions formed on the opening tab in accordance with other modifications of the second embodiment of this invention, respectively;

5 Figs. 2p to 2u are plan views, showing the construction of regularly spaced grooves formed on the upper or lower surface of the thumb-operable resilient bulge of the opening tab in accordance with other modifications of the second embodiment of this invention, respectively;

10 Figs. 2v and 2w are plan and sectional views, showing a depression formed on the can lid at a position under the depressed linear portions of the opening tab in accordance with another modification of the second embodiment of this invention;

15 Fig. 2x is a view, showing a depression formed on the can lid at a position under the depressed linear portions of the opening tab in accordance with a further modification of the second embodiment of this invention;

20 Figs. 2y and 2z are plan views, showing a desired advertising or tab opening instructional pattern provided on the thumb-operable resilient bulge of the opening tab in accordance with a modification of the second embodiment of this invention;

25 Fig. 3 is a perspective view of a can lid with an opening tab in accordance with the third embodiment of the present invention;

30 Figs. 3a to 3e are plan views, showing the construction of opening tabs collaterally acting as a sanitary cover for the opening pieces of the can lids and individually having regularly spaced grooves on the upper or lower surface of a thumb-operable resilient bulge in accordance with modifications of the third embodiment of this invention, respectively;

35 Figs. 3f to 3h are plan views, showing the construction of opening tabs collaterally acting as sanitary cover for the opening pieces of the can lids and individually having regularly spaced grooves on the upper or lower surface of a thumb-operable resilient bulge in accordance with other modifications of the third
40 embodiment of this invention, respectively;

-7-

Figs. 3i to 3l are plan views, showing the construction of opening tabs collaterally acting as a sanitary cover for the opening pieces and individually having reinforcing parts on the thumb-operable resilient bulge in accordance with modifications of the third embodiment of this invention, respectively;

Figs. 3m to 3o are plan views, showing the construction of opening tabs collaterally acting as a sanitary cover for the opening pieces and individually having depressed linear portions in accordance with modifications of the third embodiment of this invention, respectively;

Figs. 3p and 3q are plan views, showing the construction of opening tabs collaterally acting as a sanitary cover for the opening pieces and individually having depressed linear portions in accordance with other modifications of the third embodiment of this invention, respectively; and

Figs. 3r to 3t are plan views, showing the construction of opening tabs collaterally acting as a sanitary cover for the opening pieces and individually having a desired advertising or tab opening instructional pattern provided on the thumb-operable resilient bulge of the opening tab in accordance with modifications of the third embodiment of this invention, respectively.

Best Mode for Carrying Out the Invention

As shown in the accompanying drawings, the opening tab 30 provided on the can lid of this invention has a free end portion, or a first end portion 31, to which the finger force of a user is applied when the can lid is opened. A hole 34 is formed at the center of the end portion 31, while a rivet hole is formed at a fixed end portion, or a second end portion, of the opening tab 30 at which the opening tab 30 is locked to the can lid using a rivet 24. A depressed linear portion 38 in the form of a depressed groove is formed on the tab 30 at a position close to the first end portion 31 as shown in Figs. 1a to 1r. A thumb pushing part 36, having a

-8-

variety of shapes, may be provided on the tab 30 at a middle portion between the hole 34 and second end portion, thus allowing a user to more easily press the opening tab 30 downwardly. In accordance with other
5 modifications of the primary embodiment of this invention, a thumb-operable resilient bulge 33, normally swelling upwardly, may be formed on the opening tab 30 as shown in Figs. 2a to 2z. A plurality of regularly spaced grooves
10 37 in the form of a concentric circular profile, a linear profile or a comb structural profile may be formed on the upper or lower surface of the resilient bulge 33. The depressed linear portions 38, provided at positions around the first end portion 31, are depressed grooves, which
15 have a predetermined size and extend in a transverse direction. An arcuate slit 32 is formed around the rivet hole of the opening tab 30 and allows the tab 30 to be bent when the tab 30 is levered up to open the can lid. In the above opening tab 30, it is preferable for the opening tab 30 to be gradually enlarged in width in a
20 direction from the second end portion toward the first end portion 31 and to have an arcuate profile at both ends thereof.

The thumb-operable resilient bulge 33, formed at the center of the first end portion 31 of the opening tab 30,
25 is designed in that it has a shape and an elasticity, both allowing the bulge 33 to normally swell upwardly, but selectively and resiliently be convexly inverted when it is pressed down by a finger. That is, when the thumb-operable resilient bulge 33 is pressed down by a thumb of
30 a user, the bulge 33 partially and elastically raises the tab body, including the end portion 31, from the top surface 20 of the can lid while forming an appropriate gap between the tab body and the top surface of the can lid. In the present invention, several types of
35 resilient bulges 33, for example, a dome-shaped bulge as shown in Fig. 2a or an overbridge-shaped bulge as shown in Fig. 2e, may be formed on the opening tab 30. In order to allow the resilient bulge 33 to be smoothly and resiliently operated when it is pressed downwardly by a
40 finger, a plurality of regularly spaced grooves 37 in the

form of a concentric circular profile, a linear profile or a comb structural profile are formed on the upper or lower surface of the resilient bulge 33 as shown in Figs. 2a to 2u. Of course, it should be understood that the profile of the grooves 37 may be somewhat freely changed without affecting the functioning of this invention.

In the present invention, a depressed linear portion 38 in the form of a depressed groove may be formed on the first end portion 31 of the opening tab 30 while extending in a transverse direction. The above depressed linear portion 38 allows a user to easily raise the first end portion 31 of the opening tab 30 upwardly from the top surface 20 of the can lid and to allow both a tab raising action and a tab levering action to be separately and orderly performed by a user. Of course, the depressed linear portion 38 may have a variety of profiles without affecting the functioning of this invention as shown in Figs. 1a to 1r and Figs. 2j to 2z. However, it is necessary for the depressed linear portion 38 to have a sufficient strength to resist against an external force applied thereto when the seal of the opening piece 22 is broken along the depressed seam of the can lid. In the present invention, two depressed linear portions 38 may be transversely formed on opposite edges of the opening tab 30. It is thus possible to bend the first end portion 31 of the opening tab 30 upwardly from the top surface 20 of the can lid at the depressed linear portions 38 so as to form a gap between the end portion 31 and the top surface 20, with an inclination angle of the end portion 31 relative to the top surface 20 ranging from about 25° to about 30°.

Alternatively, two depressed linear portions 38 may be transversely formed on each edge of the opening tab 30 as shown in Figs. 1k to 1n and Figs. 2m to 2o. In addition, the shapes of the grooves 37 and cut reinforcing parts 35 may be changed from the shapes shown in the drawings without affecting the functioning of this invention. When an upwardly acting force is applied to the end portion 31 of the opening tab 30 having the depressed linear portions 38 as shown in Fig. 1r, the end

-10-

portion 31 is elastically raised upwardly at the depressed linear portions 38, thus forming an appropriate gap between the end portion 31 and the top surface 20 of the can lid. The gap between the end portion 31 of the opening tab 30 and the can lid allows a user to easily lever up the opening tab 30 by a finger. When the user levers up the opening tab 30 as described above, the second end portion of the opening tab 30 presses down the opening piece 22, thus breaking the seal of the opening piece 22 along the depressed seam 21 and forming an opening on the can lid.

On the other hand, in order to open the can lid having the thumb-operable resilient bulge 33 on the opening tab 30 as shown in Figs. 2a to 2z prior to emptying the can 10, the resilient bulge 33 of the opening tab 30 is primarily pressed down by a finger so as to be resiliently convexly inverted. In such a case, the bulge 33 elastically raises the end portion 31 of the opening tab 30 from the top surface 20 of the can lid while forming a substantial gap between the end portion 31 of the opening tab 30 and the top surface 20 of the can lid. Thereafter, a slight force is applied to the primarily raised end portion 31 of the opening tab 30, the end portion 31 is secondarily bent at the depressed linear portions 38, thus allowing a user to more easily handle the end portion 31 of the opening tab 30. The gap between the end portion 31 of the opening tab 30 and the can lid allows the user to easily lever up the opening tab 30 with fingers gripping the end portion 31. When the user levers up the opening tab 30 as described above, the second end portion of the opening tab 30 presses down the opening piece 22. The seal of the opening piece 22 is broken along the depressed seam 21 and forms an opening on the can lid. Therefore, it is possible for the user to empty the can through the opening formed on the can lid.

In the modifications of Figs. 1h to 1i and Figs. 1o to 1q, the opening tab 30 is provided with a thumb pushing part 36 which allows a small-sized hole 34 to be formed at a position close to the end portion 31. Such

-11-

a thumb pushing part 36 thus provides a large area on the tab 30 at a position between the hole 34 and the arcuate slit 32 and allows a user to more easily press the tab 30 with a thumb.

5 In the modifications of Figs. 1f, 1g, 2v and 2w, a depression 23 is defined on the top surface 20 of the can lid at a position under the depressed linear portions 38 of the opening tab 30. The above depression 23 allows the end portion 31 of the opening tab 30 to be more
10 easily bent at the depressed linear portions 38 when the thumb pushing part 36 or the resilient bulge 33 is pressed down by a finger so as to raise the end portion 31 of the opening tab 30 upwardly from the top surface 20 of the can lid.

15 In the modifications of Figs. 1o to 1q and Figs. 2y and 2z, a desired advertising or tab opening instructional pattern 100 in the form of letters, symbols or figures is provided on the thumb pushing part 36 or on the thumb-
operable resilient bulge 33 of the opening tab 30. The
20 formation of the above pattern 100 on the opening tab 30 may be accomplished through an intaglio process, an embossing process, a carving process and a printing process.

 In the modifications of Figs. 2d to 2i, 2k, 2l, and
25 2s to 2v, cut reinforcing parts 35 are formed on the thumb-operable resilient bulge 33 of the opening tab 30 so as to allow the resilient bulge 33 to be more smoothly operated when the bulge 33 is pressed down by a user. In the present invention, the cut reinforcing parts 35 may
30 have a variety of shapes without affecting the functioning of this invention. In addition, the opening tab 30, locked to the top surface 20 of the can lid using a rivet 24, may be designed to normally and totally cover the opening piece of the top surface 20. The above tab 30 is
35 selectively rotated on the top surface 20 at an angle of 180° prior to being levered up to break the seal of the opening piece 22 along the depressed seams 21.

 In the third embodiment of Figs. 3 to 3t, the opening tab 30 collaterally acts as a sanitary cover for
40 the opening piece 22 of the can lid. As well known to

-12-

those skilled in the art, the opening piece 22 is a portion at which the lips of a user come into contact with while emptying the can. That is, the objective of the opening tabs 30 according to the third embodiment is to remarkably improve the sanitariness of the can.

In the third embodiment, the opening tab 30 is locked to the top surface 20 of the can lid while totally covering the opening piece 22 of the top surface 20. In such a case, two depressed lines 233 are transversely formed on the opening tab 30 at appropriate positions between the thumb-operable resilient bulge 33 and the riveted end portion. A levering projection 234 is formed on the opening tab at the central position between the two depressed lines 233.

The opening tab 30 according to the third embodiment collaterally acts as a sanitary cover which totally covers the opening piece 22 of the can lid, thus preventing the opening piece 22 from being contaminated with impurities, such as dust. Therefore, the opening tab 30 of this embodiment accomplishes a desired sanitariness of the can. In order to open the can lid prior to emptying the can, the resilient bulge 33 of the opening tab 30 is pressed down by a finger, and so the bulge 33 is resiliently convexly inverted. In such a case, the bulge 33 elastically raises the end portion 31 of the opening tab 30 from the top surface 20 of the can lid. Thereafter, the opening tab 30 is levered up, thus being bent upwardly at the depressed lines 233 as shown in Fig. 3. In such a case, the levering projection 234 of the opening tab 30 is protruded from the arcuate cutting line 232 and presses the opening piece 22 of the can lid downwardly, thus breaking the seal of the opening piece 33 along the depressed seam 21 and forming an opening on the can lid. In a brief description, the opening tab 30 according to the third embodiment of Figs. 3 to 3t has its original function as a can opening means and a collateral function as a sanitary cover for the opening piece 22. Therefore, the opening tab 30 of the third embodiment remarkably improves the sanitariness of a can in addition to the enhanced opening function.

-13-

In the above-mentioned third embodiment, a desired advertising or tab opening instructional pattern 100 in the form of letters, symbols or figures may be provided on the opening tab 30 as shown in Figs. 3r to 3t. In addition, cut reinforcing parts 35 may be formed on the thumb-operable resilient bulge 33 of the opening tab 30 as shown in Figs. 3i to 3l. In this embodiment, a plurality of regularly spaced grooves 37 in the form of a concentric circular profile, a linear profile or a comb structural profile may be formed on the upper or lower surface of the resilient bulge 33 as shown in Figs. 3a to 3h. The above depressed linear portions 38 allow the resilient bulge 33 to be more smoothly operated when the bulge 33 is pressed down by a finger. Furthermore, one or more depressed linear portions 38 in the form of depressed grooves having a predetermined size may be formed on the first end portion 31 of the opening tab 30 as shown in Figs. 3m to 3q.

20 Industrial Applicability

As described above, the present invention provides a can lid structure with an opening means providing enhanced opening function and improved sanitarness. The opening means of this invention allows a user to easily, simply and sanitarily open and empty a can. The present invention thus accomplishes a desired sanitarness of cans while being very convenient to users.

Although the preferred embodiments of the present invention have been disclosed for illustrative purposes, those skilled in the art will appreciate that various modifications, additions and substitutions are possible, without departing from the scope and spirit of the invention as disclosed in the accompanying claims.

-14-

Claims:

1. A can lid structure, comprising an opening piece formed on a can lid along a depressed seam, and an opening tab exteriorly attached to the can lid and used
5 for breaking the seal of the opening piece along the depressed seam when necessary, said opening tab being locked to the can lid at its fixed end portion using a rivet, said tab also having both an arcuate slit formed around a riveted junction and a hole at a position
10 between the fixed end portion and a free end portion, wherein

depressed linear portions are formed on the opening tab at opposite edges around said free end portion so as to allow the free end portion to be easily raised
15 upwardly from the can lid at the depressed linear portions, said depressed linear portions being depressed grooves having a predetermined size and extending in a transverse direction.

2. The can lid structure according to Claim 1,
20 wherein a depression is externally formed on the can lid at a position between the depressed linear portions and the arcuate slit of the opening tab, thus allowing the free end portion of the tab to be more easily raised upwardly at the depressed linear portions when the
25 depressed linear portions are pressed downwardly.

3. The can lid structure according to Claim 1, wherein a thumb pushing part is provided on said tab at a side of the depressed linear portions and allows the depressed linear portions to be more easily operated.

30 4. The can lid structure according to Claim 1 or 3, wherein a desired advertising or tab opening instructional pattern is provided on the thumb pushing part of said opening tab.

5. A can lid structure, comprising an opening piece
35 formed on a can lid along a depressed seam, and an

-15-

opening tab exteriorly attached to the can lid and used for breaking the seal of the opening piece along the depressed seam when necessary, said opening tab being locked to the can lid at its fixed end portion using a rivet, said tab also having an arcuate slit formed around a riveted junction, with a thumb-operable resilient bulge being provided on the tab at a position between the fixed end portion and a free end portion so as to allow the free end portion of the tab to be easily raised upwardly from the can lid, wherein

a plurality of regularly spaced and appropriately sized grooves in the form of a concentric circular profile are formed on a lower surface of said thumb-operable resilient bulge, thus allowing the bulge to be smoothly operated.

6. The can lid structure according to Claim 5, wherein a cut reinforcing part is formed on said thumb-operable resilient bulge of the opening tab so as to allow the resilient bulge to be more smoothly operated.

7. The can lid structure according to Claim 5 or 6, wherein depressed linear portions are formed on the opening tab at opposite edges around said free end portion so as to allow the free end portion to be more easily raised upwardly from the can lid at the depressed linear portions, said depressed linear portions being depressed grooves having a predetermined size and extending in a transverse direction.

8. The can lid structure according to Claim 1 or 7, wherein two or more depressed linear portions are formed on the opening tab at each edge around said free end portion so as to allow the free end portion of the opening tab to be more easily raised upwardly from the can lid at the depressed linear portions.

9. The can lid structure according to Claim 5 or 6, wherein a plurality of regularly spaced and regularly sized grooves in the form of a linear profile or a comb

-16-

structural profile are formed on the lower surface of said thumb-operable resilient bulge, thus allowing the bulge to be smoothly operated.

10. The can lid structure according to Claim 5 or 6,
5 wherein a depression is externally formed on the can lid at a position between depressed linear portions, transversely formed on the opening tab at opposite edges around the free end portion, and the arcuate slit of the opening tab, thus allowing the free end portion of the
10 tab to be more easily raised upwardly at the depressed linear portions when the depressed linear portions are pressed downwardly.

11. The can lid structure according to any one of Claims 5, 6 and 9, wherein a plurality of regularly
15 spaced, regularly sized and regularly shaped grooves are formed on an upper surface of said thumb-operable resilient bulge, thus allowing the bulge to be smoothly operated.

12. The can lid structure according to Claim 5 or 6,
20 wherein a desired advertising or tab opening instructional pattern is provided on the thumb pushing part of said opening tab.

13. A can lid structure, comprising an opening piece formed on a can lid along a depressed seam, and an
25 opening tab exteriorly attached to the can lid and used for normally covering the opening piece and selectively breaking the seal of the opening piece along the depressed seam when necessary, said opening tab being locked to the can lid at its fixed end portion using a
30 rivet, said tab also having an arcuate cutting line at a middle portion, with two depressed lines transversely extending from both ends of said arcuate cutting line to opposite edges of the tab, a thumb-operable resilient bulge being provided on the tab at a position between the
35 depressed lines and a free end portion of the tab so as to allow the free end portion of the tab to be easily

-17-

raised upwardly from the can lid, and a levering projection being formed by the arcuate cutting line and pressing the opening piece of the can lid downwardly when the tab is bent at the depressed lines, thus
5 breaking the seal of the opening piece along the depressed seam, wherein

a plurality of regularly spaced and appropriately sized grooves in the form of a concentric circular profile, a linear profile or a comb structural profile
10 are formed on an upper or lower surface of said thumb-operable resilient bulge, thus allowing the bulge to be smoothly operated.

14. The can lid structure according to Claim 13, wherein a cut reinforcing part is formed on said thumb-
15 operable resilient bulge of the opening tab so as to allow the resilient bulge to be more smoothly operated.

15. The can lid structure according to Claim 13 or 14, wherein one or more depressed linear portions are formed on the opening tab at each edge around said free
20 end portion so as to allow the free end portion to be more easily raised upwardly from the can lid at the depressed linear portions, said depressed linear portions being depressed grooves having a predetermined size and extending in a transverse direction.

25 16. The can lid structure according to Claim 13 or 14, wherein a desired advertising or tab opening instructional pattern is provided on the thumb pushing part of said opening tab.

1/29
FIG. 1

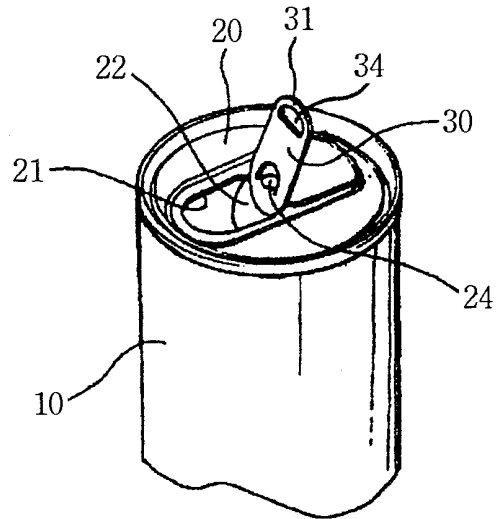
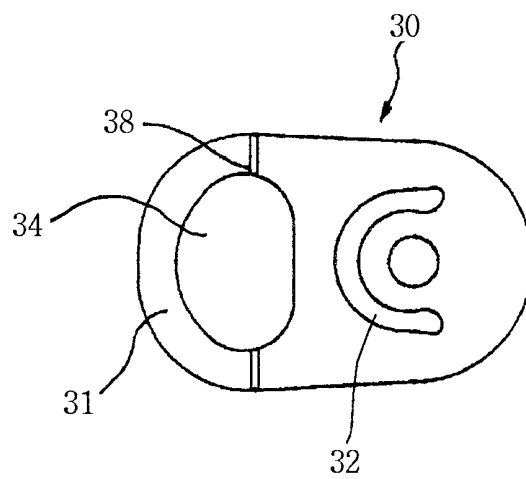

FIG. 1A



2/29

FIG. 1B

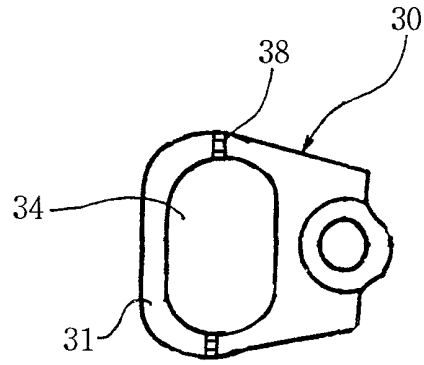

FIG. 1C

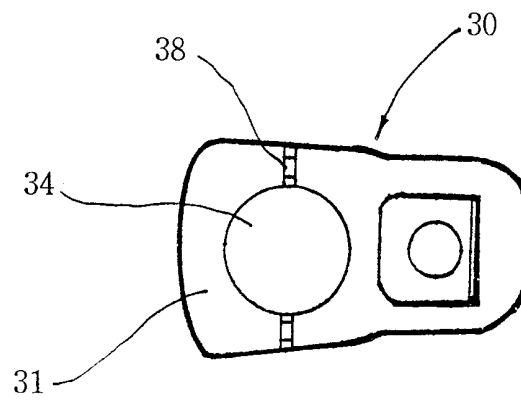

FIG. 1D

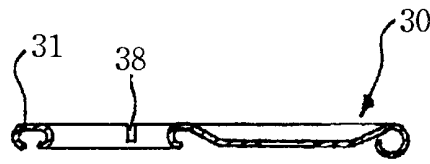
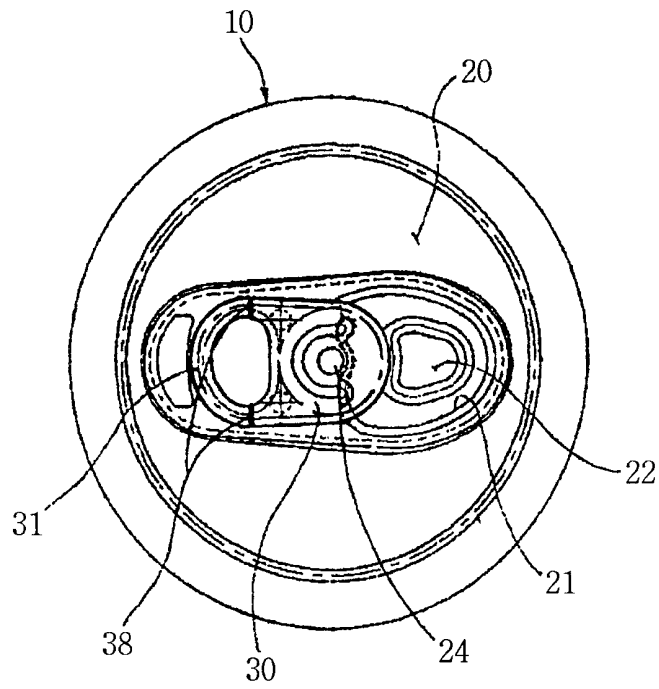

FIG. 1E



4/29
FIG. 1F

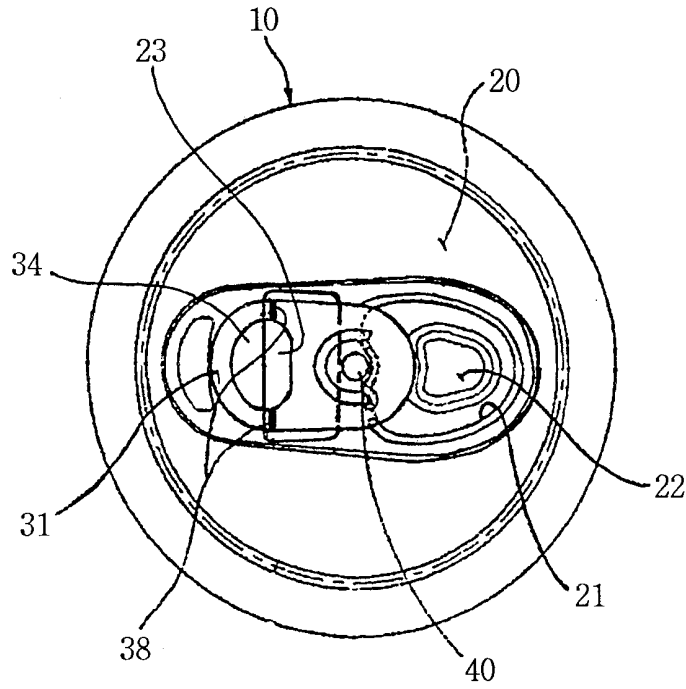
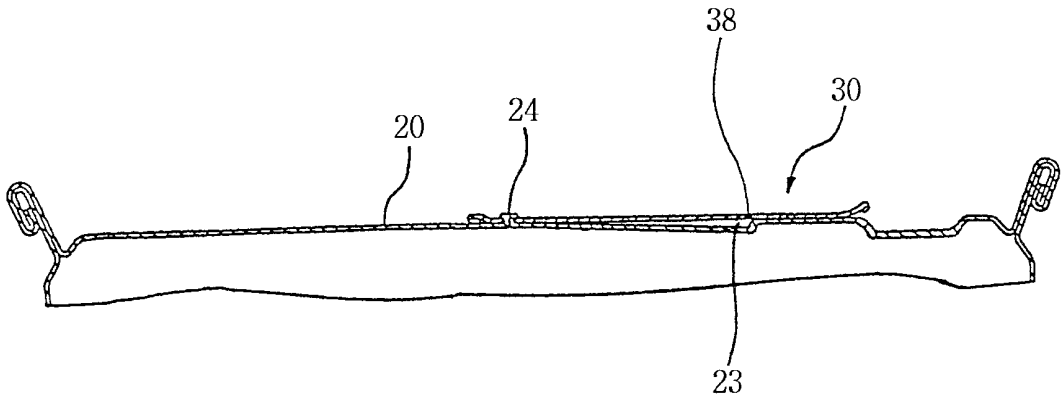

FIG. 1G



5/29

FIG. 1H

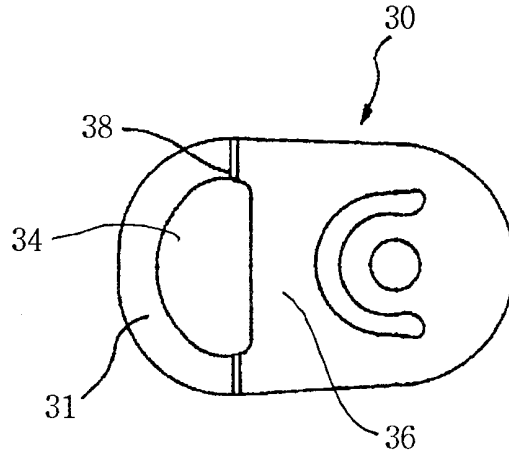

FIG. 1I

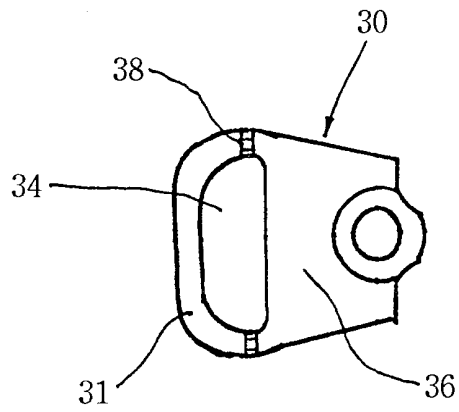
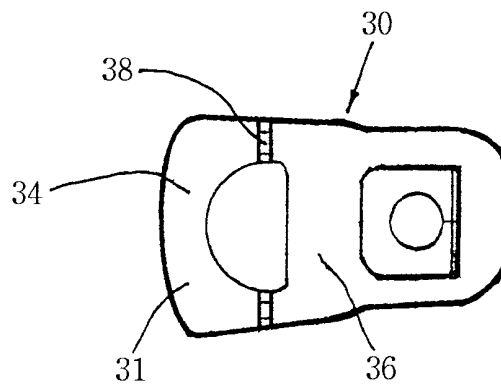
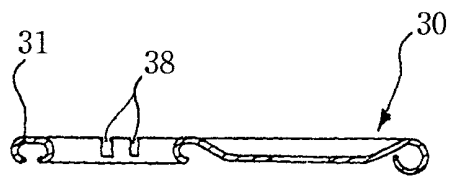

FIG. 1J



6/29
FIG. 1K



7/29

FIG. 1L

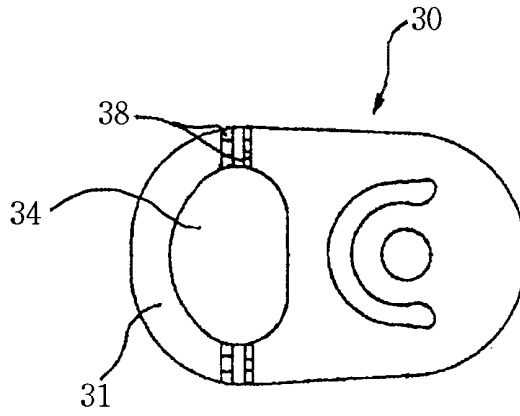

FIG. 1M

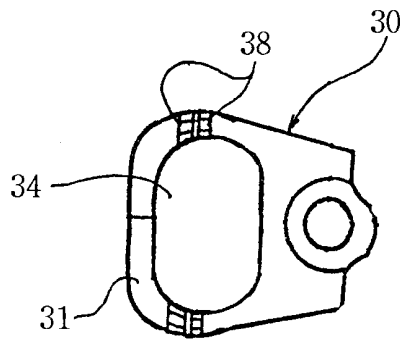
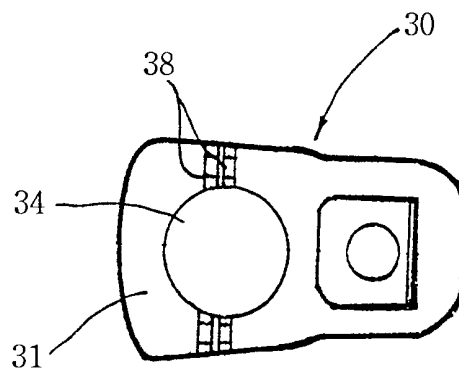

FIG. 1N



8/29
FIG. 10

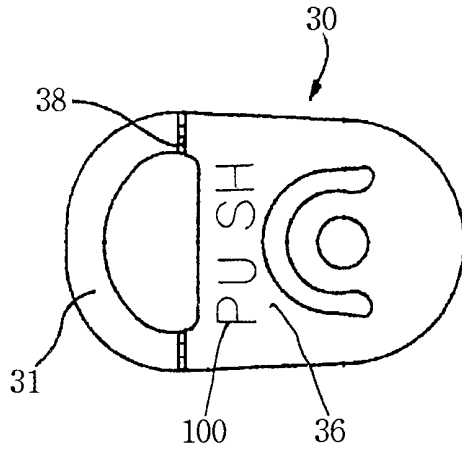

FIG. 1P

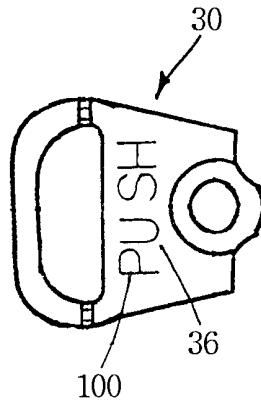
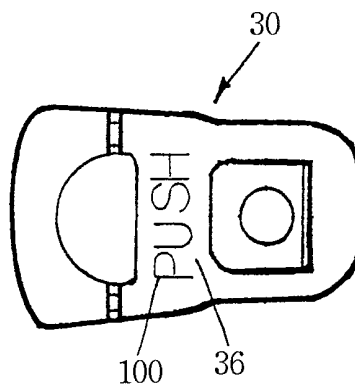
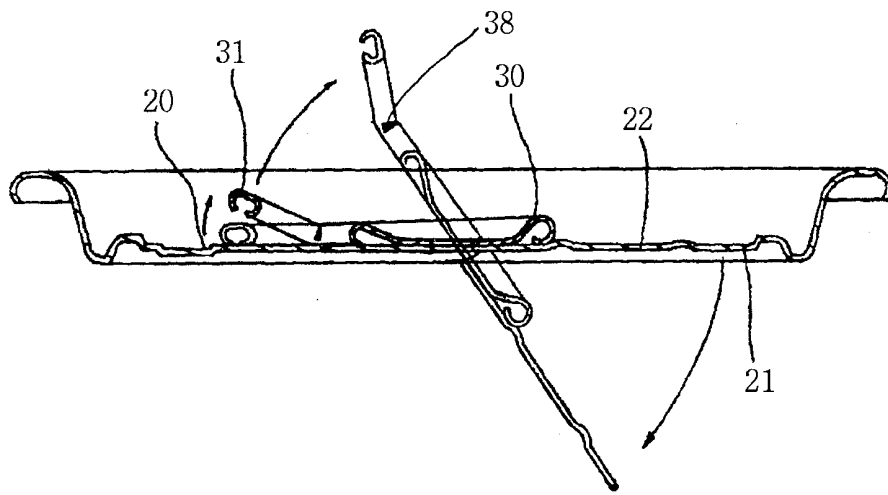

FIG. 1Q



9/29
FIG. 1R



10/29
FIG. 2

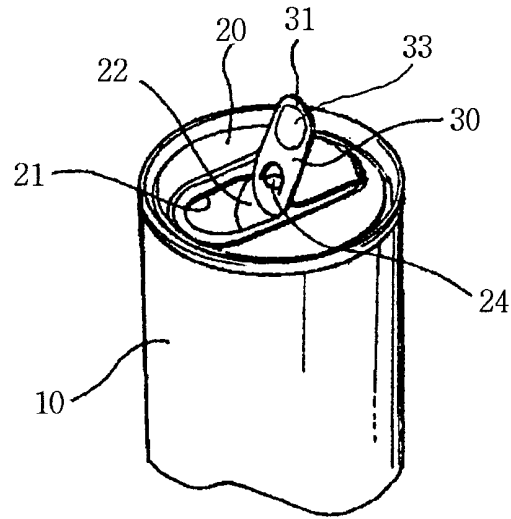
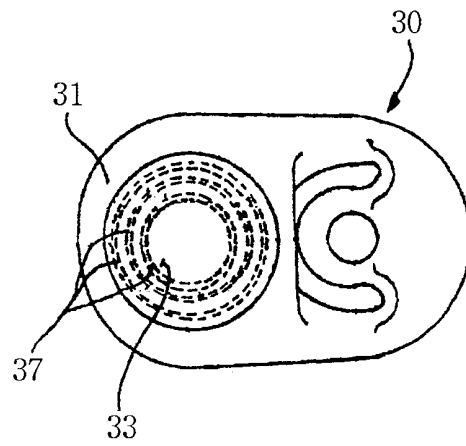

FIG. 2A



11/29

FIG. 2B

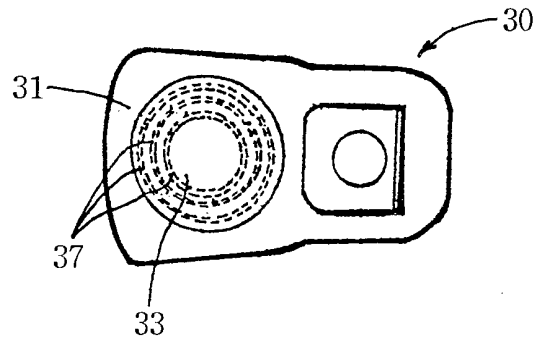
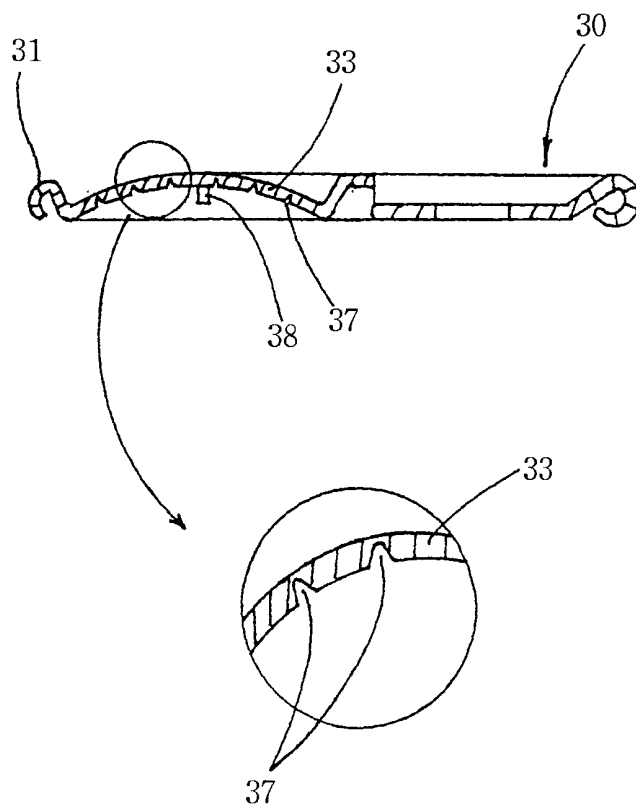

FIG. 2C



12/29
FIG. 2D

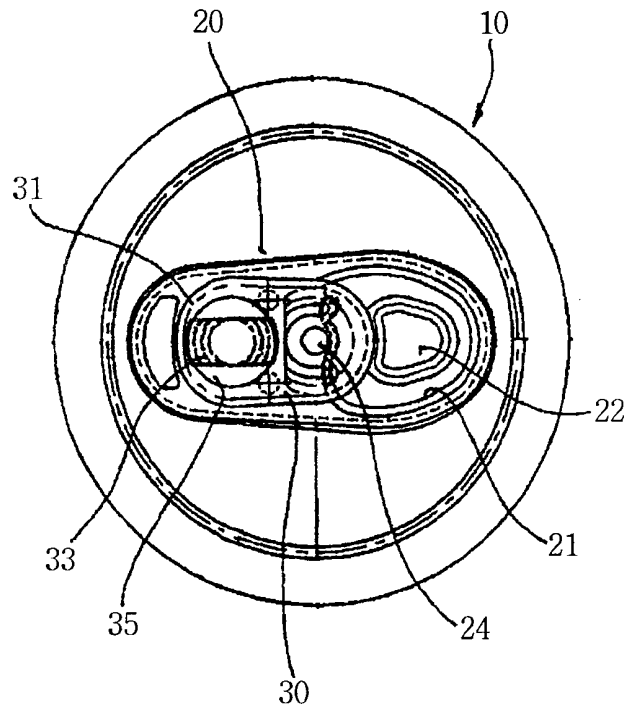
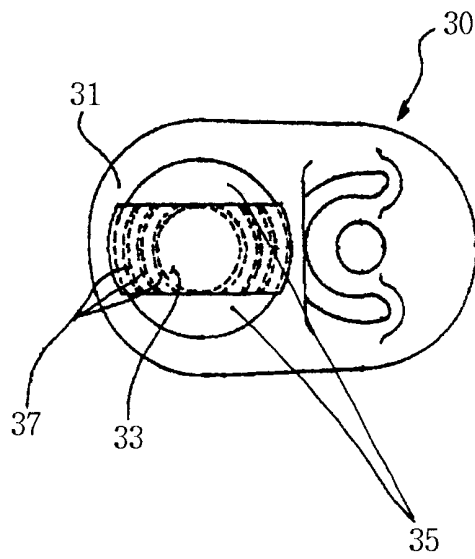
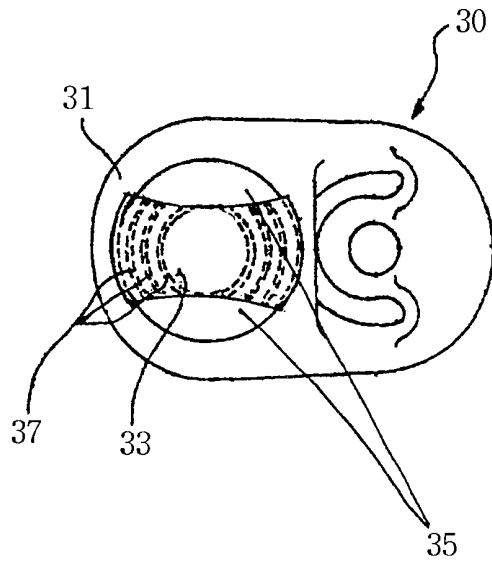

FIG. 2E



13/29
FIG. 2F



14/29

FIG. 2G

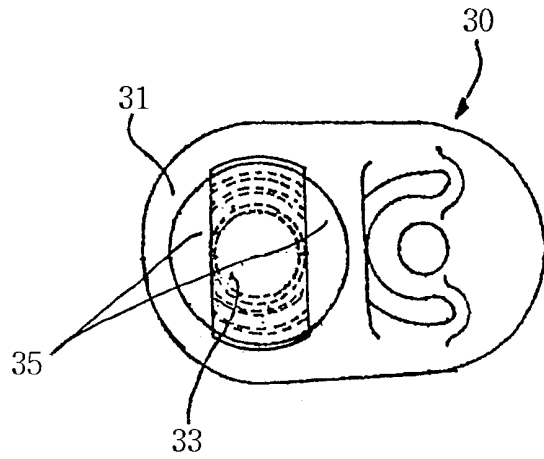

FIG. 2H

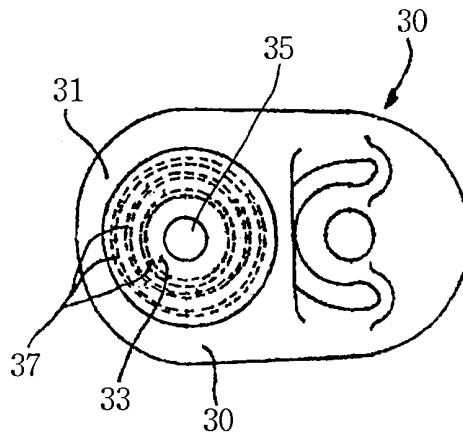
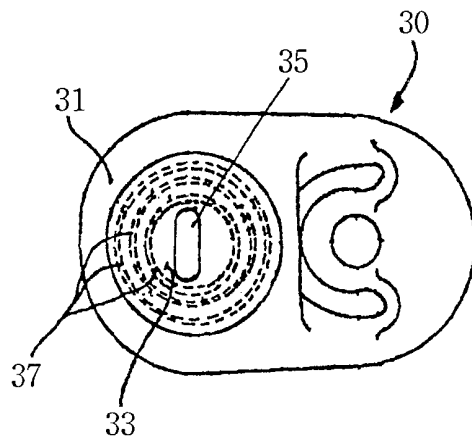

FIG. 2I



15/29

FIG. 2J

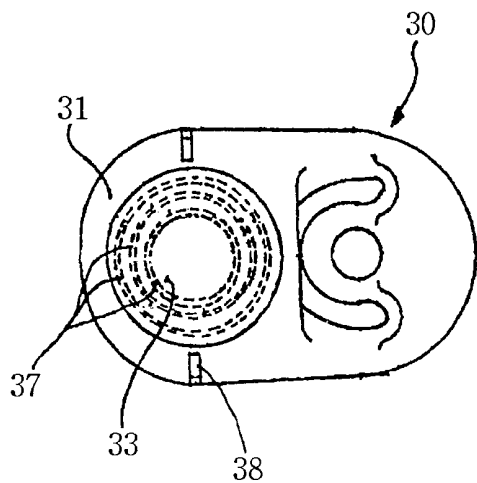

FIG. 2K

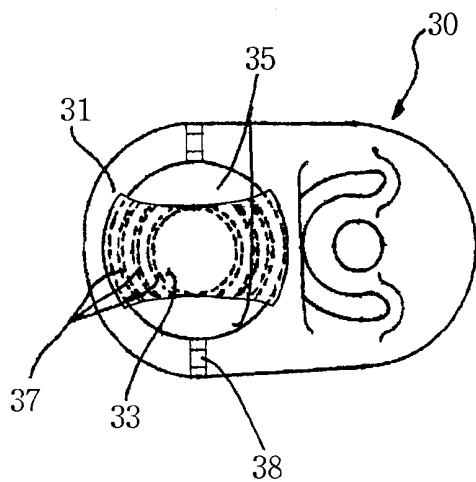
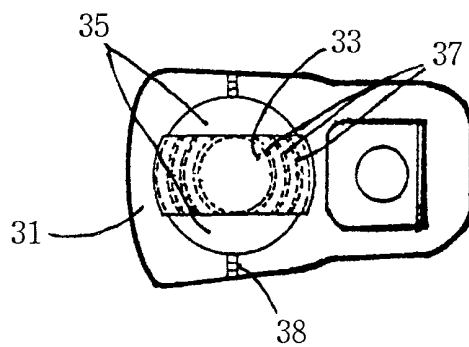

FIG. 2L



16/29

FIG. 2M

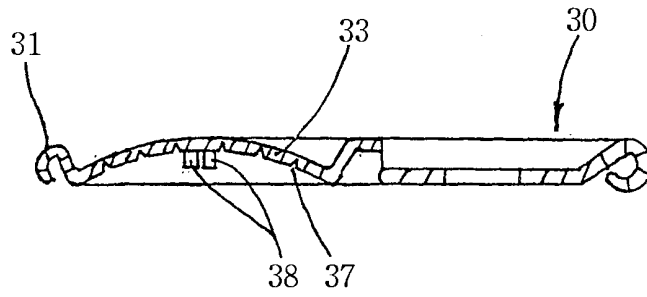

FIG. 2N

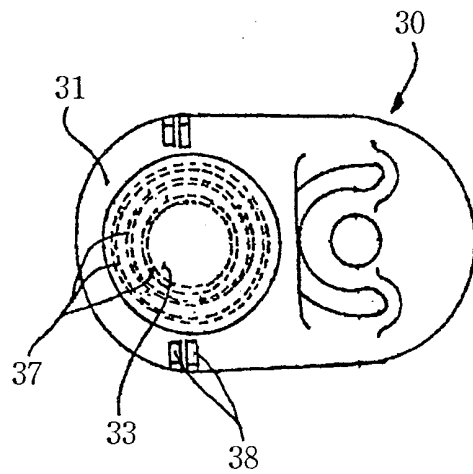
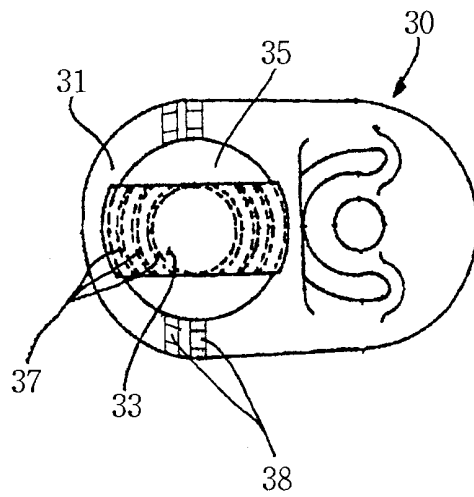

FIG. 2O



17/29
FIG. 2P

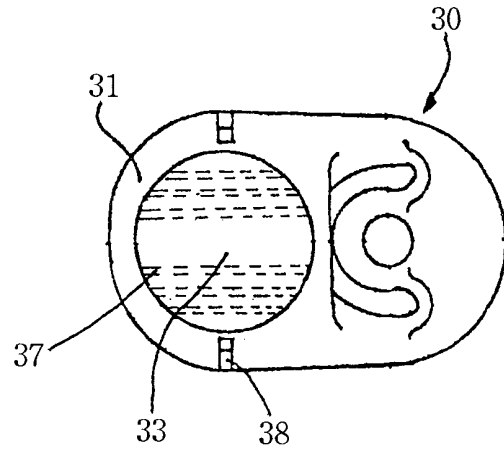

FIG. 2Q

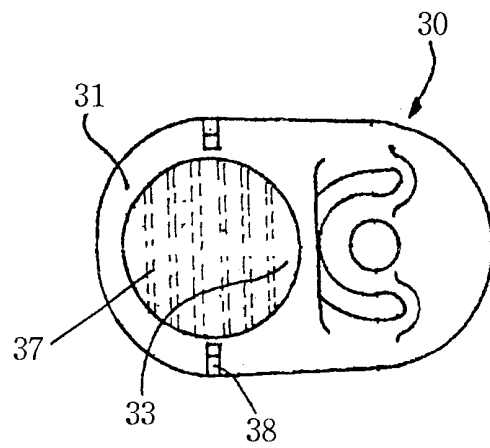
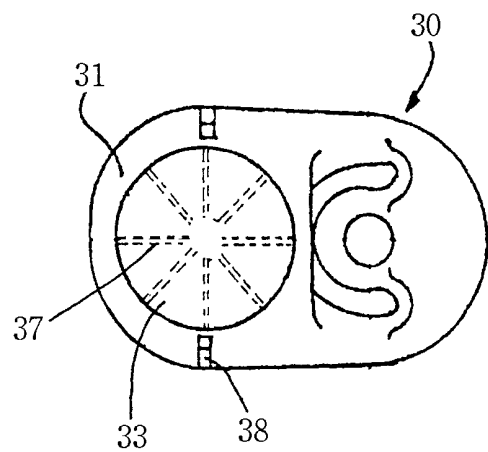

FIG. 2R



18/29
FIG. 2S

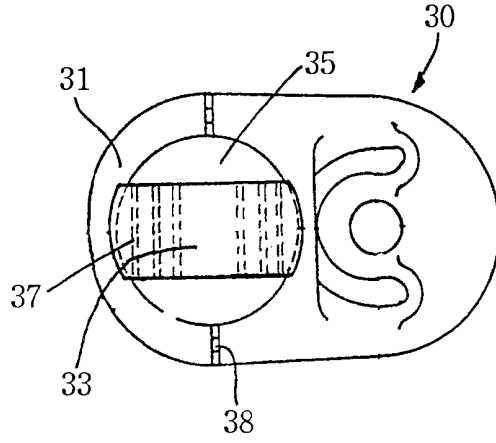

FIG. 2T

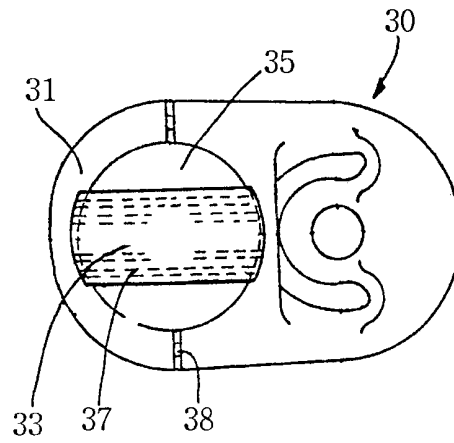
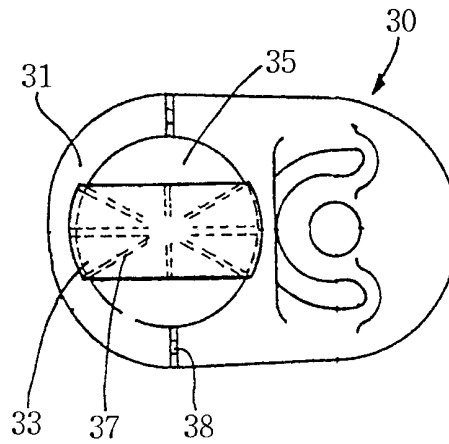

FIG. 2U



19/29
FIG. 2V

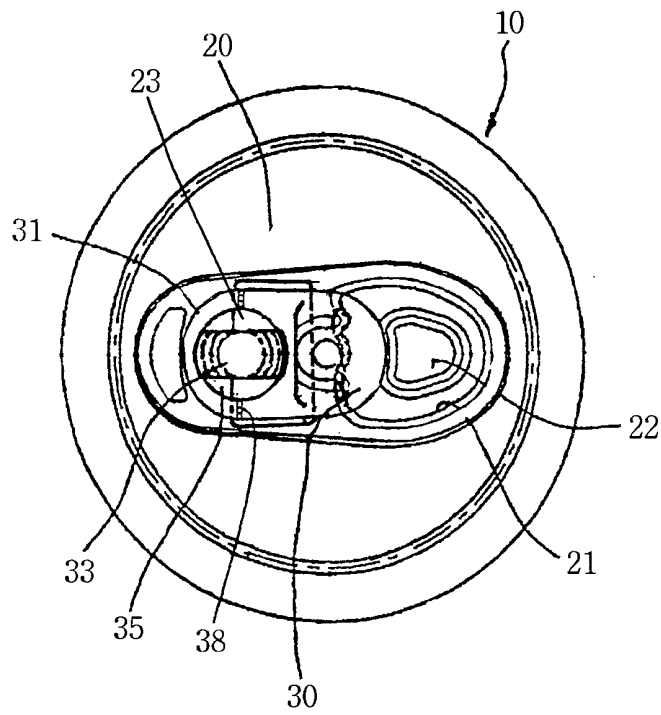
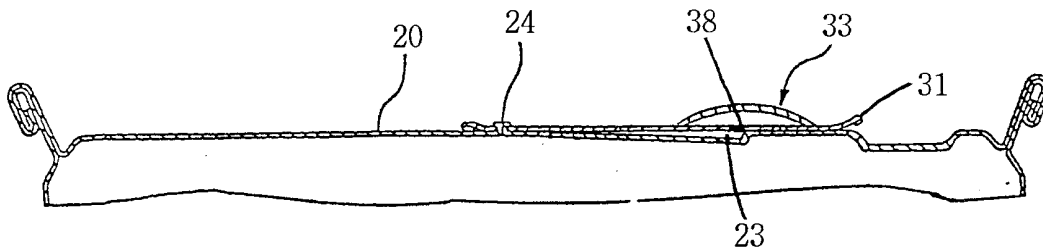
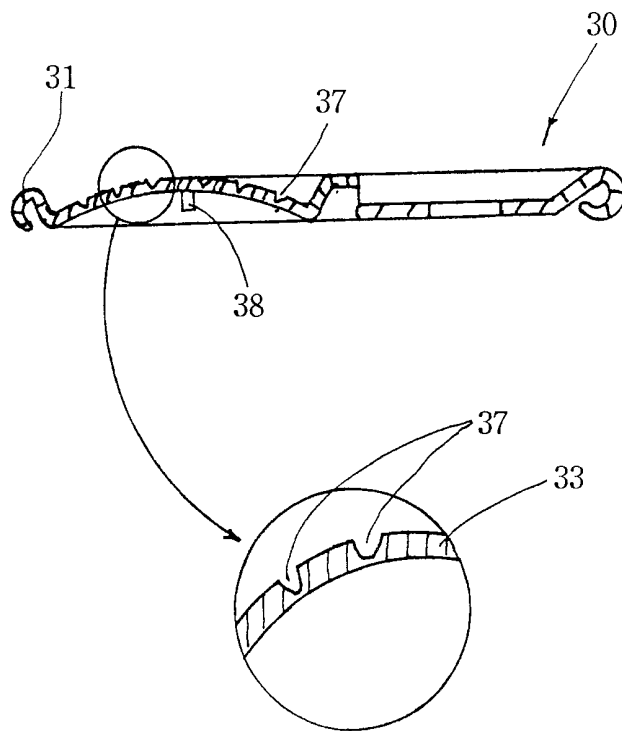

FIG. 2W



20/29
FIG. 2X



21/29

FIG. 2Y

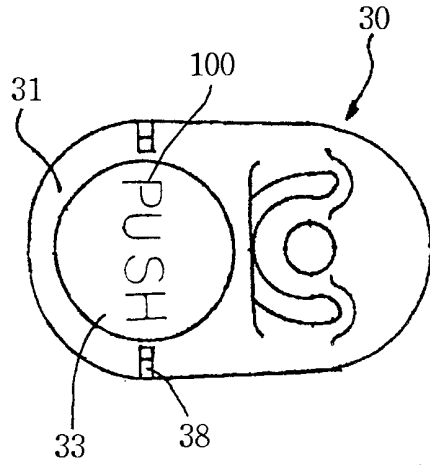
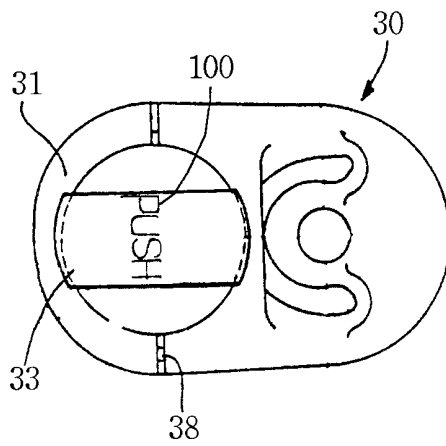

FIG. 2Z



22/29
FIG. 3

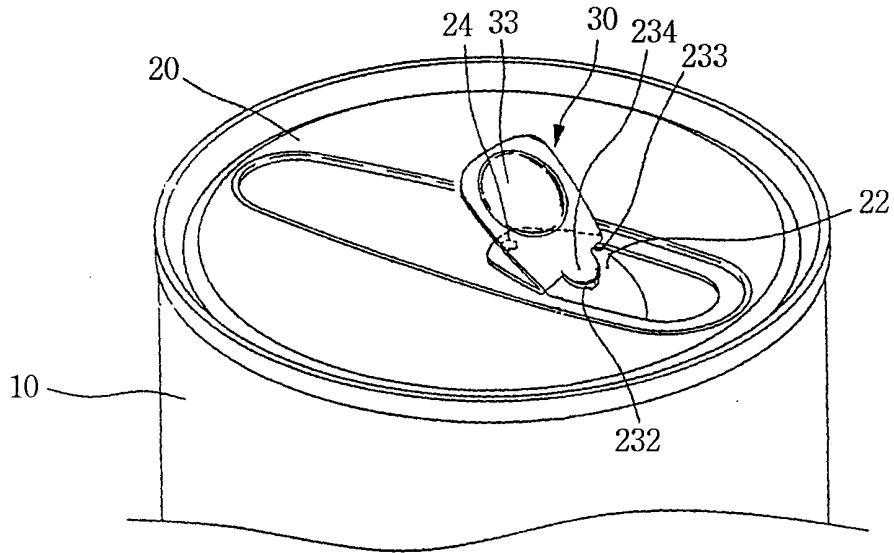

FIG. 3A

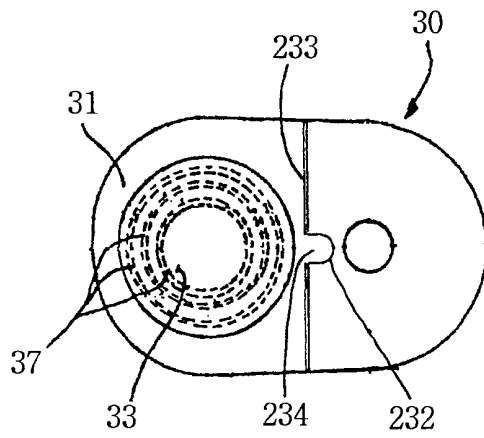
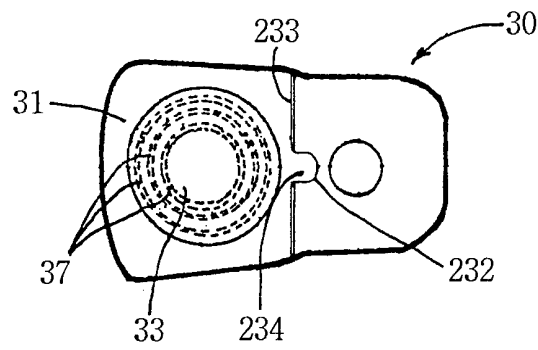

FIG. 3B



23/29
FIG. 3C

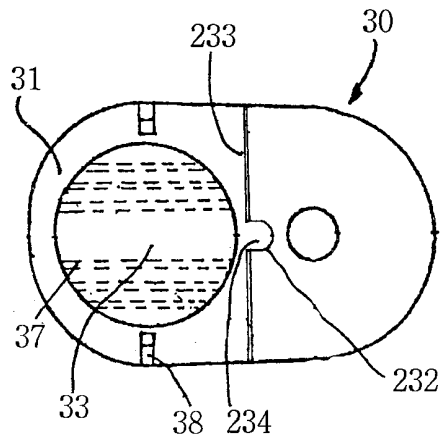

FIG. 3D

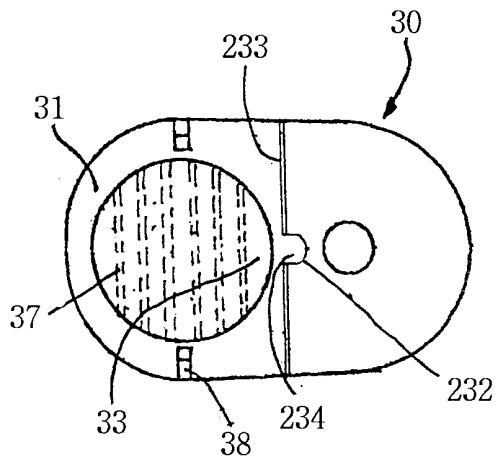
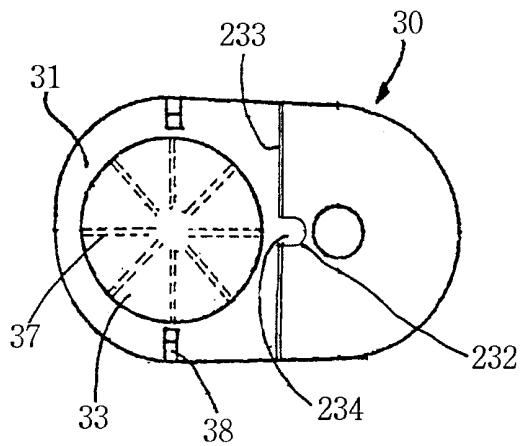

FIG. 3E



24/29
FIG. 3F

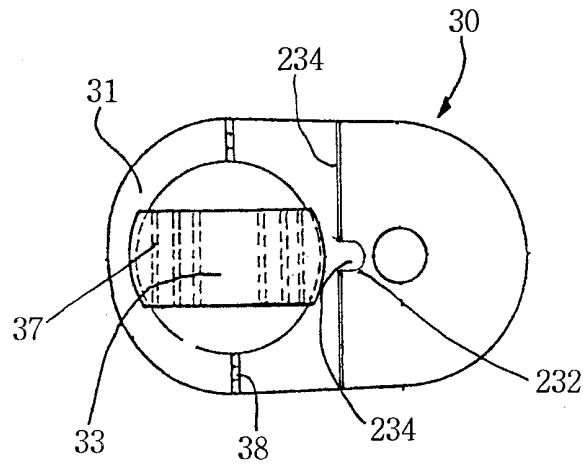

FIG. 3G

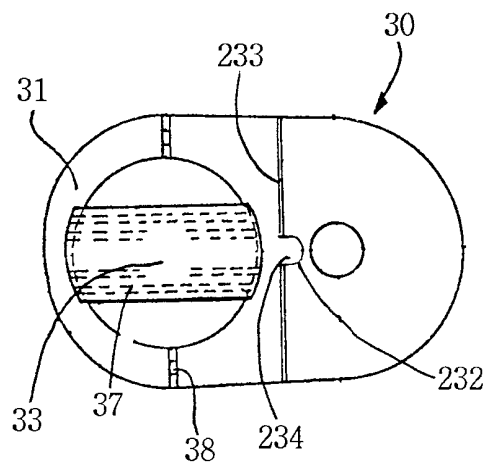
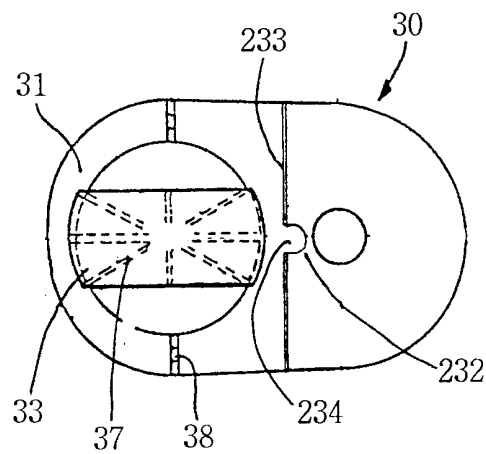
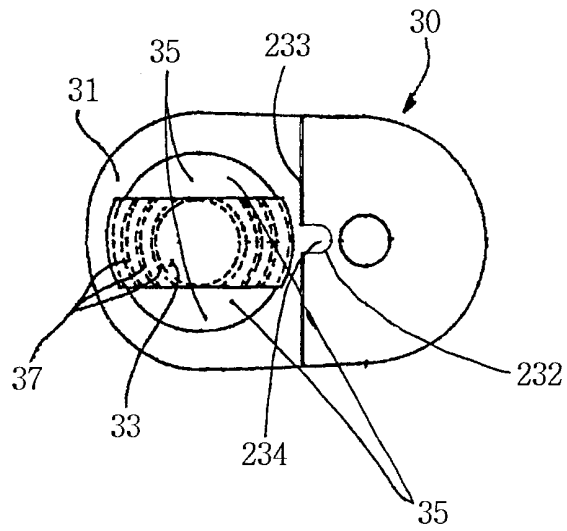

FIG. 3H



25/29
FIG. 3I



26/29
FIG. 3J

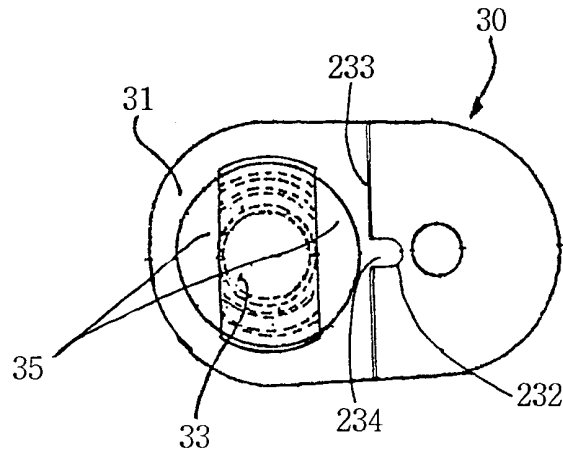

FIG. 3K

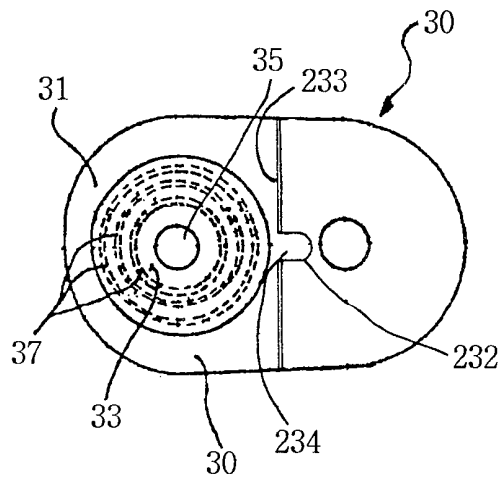

FIG. 3L

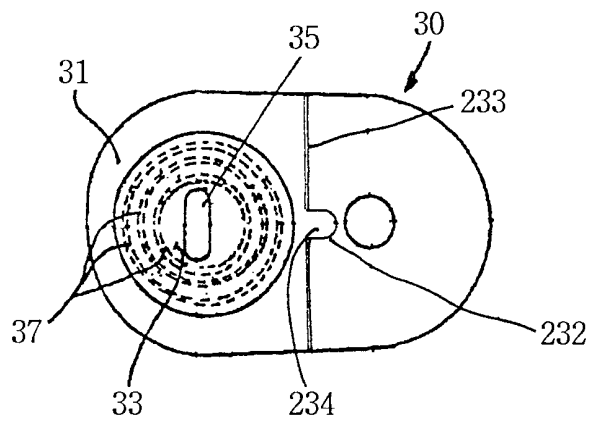

FIG. 3M

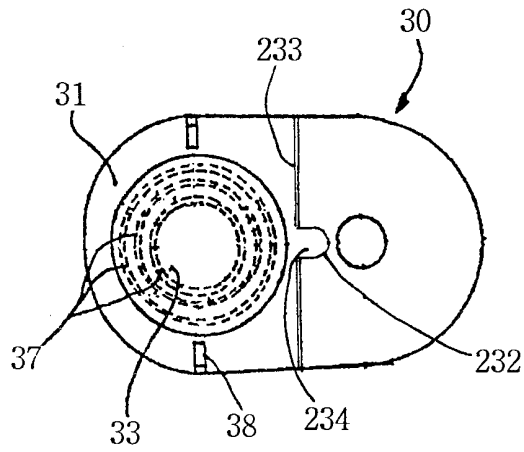

FIG. 3N

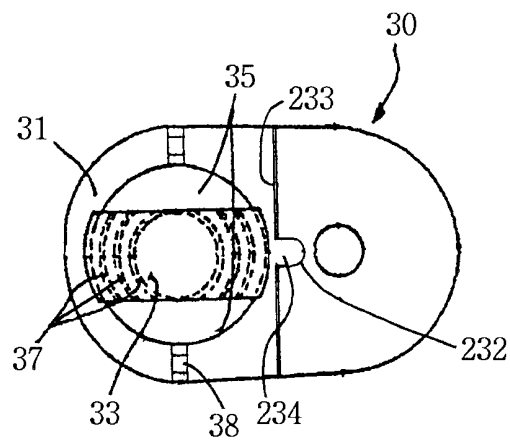

FIG. 3O

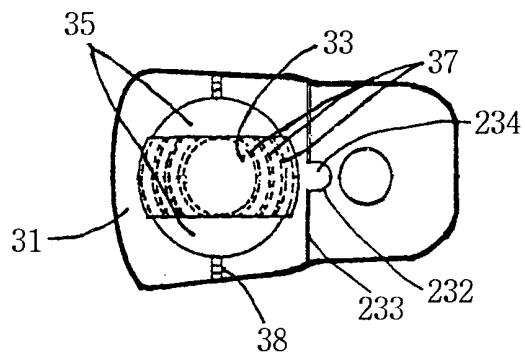

FIG.3P

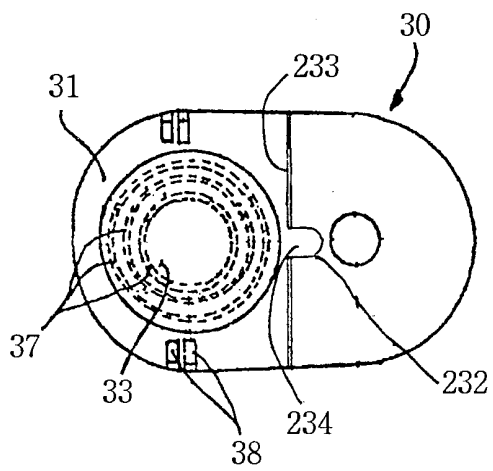
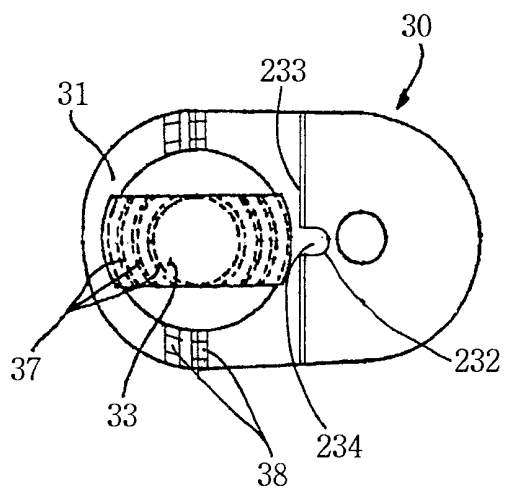

FIG.3Q



29/29
FIG. 3R

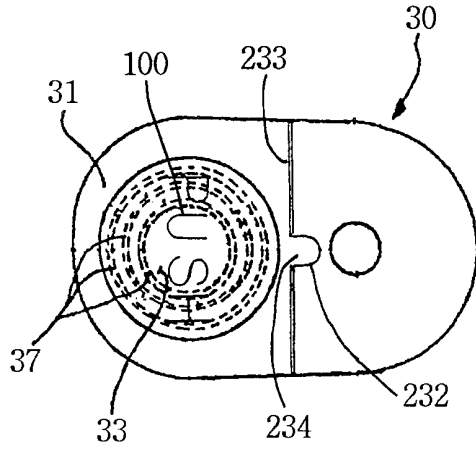

FIG. 3S

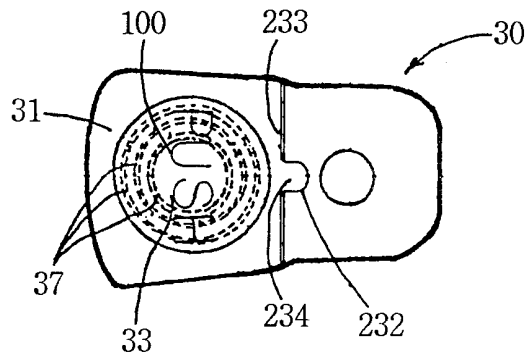
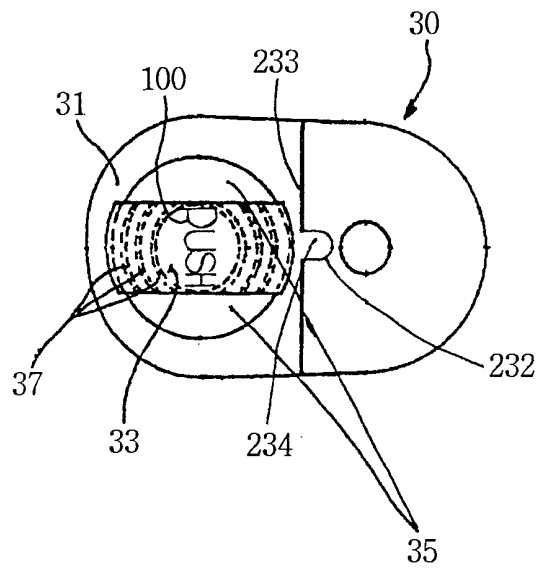

FIG. 3T



INTERNATIONAL SEARCH REPORT

International application No.
PCT/KR 99/00685

CLASSIFICATION OF SUBJECT MATTER		
IPC ⁷ : B 65 D 17/34		
According to International Patent Classification (IPC) or to both national classification and IPC		
B. FIELDS SEARCHED		
Minimum documentation searched (classification system followed by classification symbols)		
IPC ⁷ : B 65 D; B 65 B; B 21 D		
Documentation searched other than minimum documentation to the extent that such documents are included in the fields searched		
Electronic data base consulted during the international search (name of data base and, where practicable, search terms used)		
WPI, EPODOC, PAJ		
C. DOCUMENTS CONSIDERED TO BE RELEVANT		
Category	Citation of document, with indication, where appropriate, of the relevant passages	Relevant to claim No.
A	WO 99/01243 A (CROWN CORK) 14 January 1999 (14.01.99) fig.1-3.	1-16
A	US 4465204 A (KAMINSKI et al.) 14 August 1984 (14.08.84) fig.3-7.	1-16
A	US 5335808 A (LEE) 9 August 1994 (09.08.94) totality.	5-16
A	US 4463866 A (MANDEL) 7 August 1984 (07.08.84) fig.1-9.	2,5-16
A	US 4720022 A (GOMES) 19 January 1988 (19.01.88) fig.1-7.	5-16

<input type="checkbox"/> Further documents are listed in the continuation of Box C. <input checked="" type="checkbox"/> See patent family annex.		
* Special categories of cited documents: „A“ document defining the general state of the art which is not considered to be of particular relevance „E“ earlier application or patent but published on or after the international filing date „L“ document which may throw doubts on priority claim(s) or which is cited to establish the publication date of another citation or other special reason (as specified) „O“ document referring to an oral disclosure, use, exhibition or other means „P“ document published prior to the international filing date but later than the priority date claimed „T“ later document published after the international filing date or priority date and not in conflict with the application but cited to understand the principle or theory underlying the invention „X“ document of particular relevance; the claimed invention cannot be considered novel or cannot be considered to involve an inventive step when the document is taken alone „Y“ document of particular relevance; the claimed invention cannot be considered to involve an inventive step when the document is combined with one or more other such documents, such combination being obvious to a person skilled in the art „&“ document member of the same patent family		
Date of the actual completion of the international search 29 February 2000 (29.02.2000)		Date of mailing of the international search report 11 August 2000 (11.08.2000)
Name and mailing address of the ISA/AT Austrian Patent Office Kohlmarkt 8-10; A-1014 Vienna Facsimile No. 1/53424/535		Authorized officer Werner Telephone No. 1/53424/357

INTERNATIONAL SEARCH REPORT

Information on patent family members

International application No.

PCT/KR 99/00685

Patent document cited in search report			Publication date	Patent family member(s)	Publication date
US	A	4463866	07-08-1984	none	
US	A	4465204	14-08-1984	AU A1 26292/84	17-01-1985
				AU B2 562930	25-06-1987
				BE A1 899515	16-08-1984
				BR A 8402027	26-03-1985
				CA A1 1208145	22-07-1986
				CH A 664539	15-03-1988
				DE A1 3415643	24-01-1985
				DK A0 1592/84	19-03-1984
				DK A 1592/84	14-01-1985
				DK B 161762	12-08-1991
				DK C 161762	27-01-1992
				FR A1 2550767	22-02-1985
				FR B1 2550767	01-07-1988
				GB A0 8407981	10-05-1984
				GB A1 2143202	06-02-1985
				GB B2 2143202	13-05-1987
				IT A0 8467648	26-06-1984
				IT A 1178985	16-09-1987
				JP A2 60023145	05-02-1985
				JP B4 6059897	10-08-1994
				MX A 160925	19-06-1990
				NL A 8400872	01-02-1985
				NL B 192736	01-09-1997
				NL C 192736	06-01-1998
				SE A0 8401659	26-03-1984
				SE A 8401659	14-01-1985
				US A 4530631	23-07-1985
US	A	4720022	19-01-1988	none	
US	A	5335808	09-08-1994	none	
WO	A	9901243A		none	