

(19) (KR)  
(12) (B1)

(51) 。 Int. Cl. <sup>7</sup>  
H04N 7/26

(45) 2001 07 12  
(11) 10 - 0292355  
(24) 2001 03 23

(21) 10 - 1998 - 0035846  
(22) 1998 09 01

(65) 2000 - 0018311  
(43) 2000 04 06

(73)

3 416

(72)

233 - 11 5 407

6 222 906

(74)

:

(54)

가 가 (Pmin) ; (a) ; (b) ; (c) 가 ; (MMAE) (Pmax) ; ( max, min) ;

- 1
- 2
- 3
- 4 DPC
- 5 PSAD
- 6 2
- 7 K PSNR
- 8
- 9
- 10
- 11
- 12
- 13

가 (VLC) , 가 가 HDTV, , 가 가 (DCT) , 가 가 (MPEG), H.261 (blocking matching motion estimation) .

(dissimilarity measure, ) ( ) ,  
 ( ) 가가 ( ) ,

가  
 ' (sum of absolute difference: SAD ) 가 1  
 SAD (u,v) 가 ,

1

$$SAD(u,v) = \sum_{i=1}^{N-1} \sum_{j=1}^{M-1} |rb(i,j) - sw(i+u,j+v)|, \quad -p \leq u,v < p$$

1 , NxM, ( -p, -p) (p-1, p-1) , rb(i,j)  
 (i,j) , sw(i,j) (i,j)

가 , 가 16 x 16 , SAD  
 , 256 , 가 64 x 6  
 4 , 1048576 .

가 , k n x n , p x p  
 2 k k 1 (k + 2log<sub>2</sub> n)  
 x p<sup>2</sup> , (k + 2log<sub>2</sub> n) 가 n<sup>2</sup> x p<sup>2</sup> . 가 2 x n<sup>2</sup>

가  
 SAD (full search) ,  
 SAD .

, (a)

E) , (a - 1) 가 가 (MAE) ; (a - 2) (MMA

(b) ; (c) 가 가 ,

(a) , ; (MAE) (MMAE) 가

(b) ,

(c) , (c - 1) (a) (b) ; (c - 2) 가 가

8 , 2

, (a) ; (b) ; (c) 가 가

(a) , (a - 1) ; (a - 2) (P max) (Pmin) ( max, min) ; (a - 3) , (b) (c)

(a)

( max, min) ; (Pmax) ; (Pmin)

, (a)

; (b)

; (c)

가

가

(a)

, (a - 1)

가 가

(MAE)

(MMAE)

max)

(Pmin)

; (a - 2)  
( max, min)

; (a - 3)

(P

, (b)

(c)

(a)

(MAE)

; (MMAE)  
(Pmax)

가 가

( max, min)

(Pmin)

(Pmax)

(Pmin)

(MMAE)

( max, min)

가

가

; 가

(MMAE)

( max, min)

(Pmax)

(Pmin)

1.

1

15

(1)

(subsampling)

, (2)

, (3)

가 ,

1

가

100

가

(1)

, (2)

, (3)

(LRQME

: low - resolution quantization motion estimation)

1.1

(truncation )

가

가

2

Lloyd - Max

2

MSE

Lloyd - Max

(mean squared error:MSE)

MSE

(MAE: mean absolute error)

. Lloyd - Max

가

가

MAE  $\overline{E}_g$  Lloyd - Max  $t_1, t_2, t_3$  1:2:3:4

가 가 ( '가 ' ) 가

2

$$\overline{E}_g = \frac{1}{N^2} \sum_{i=1}^L \sum_{x \in X_i} |P(x) - \hat{P}(x)|$$

3

$$\frac{\partial \overline{E}_g}{\partial t_i} = 0, \langle \text{DATASIZE}=872 \text{OPTION}=0 \rangle \frac{\partial \overline{E}_g}{\partial r_j} = 0 \text{ for } i=1..L-1, j=1..L$$

4

$$t_3 = -t_1 = \frac{3}{2N^2} \sum_{i=0}^{N-1} \sum_{j=0}^{N-1} |P(i,j) - \bar{P}|, t_2 = 0$$

2,  $X_i$   $P(x), \hat{P}(i,j), \bar{P}$  ,  $t_i$  ,  $r_i$  , L

2 , 4 가

가 , 가 가 가 가 가 (tie - score problem)

1.2

가 (DPC: different pixel count)  $\hat{R}(i,j), \hat{S}(i,j)$

5

$$\langle PSTYLESPACE=100 \rangle DPC(u,v) = \sum_{i=0}^{M-1} \sum_{j=0}^{N-1} \langle LELSPACE=100 \rangle [\hat{R}(i,j), \hat{S}(i+u, j+v)]$$

$$\langle PSTYLESPACE=100 \rangle \hat{S}(x,y) = 1 \text{ when } x \neq y, 0 \text{ otherwise}$$

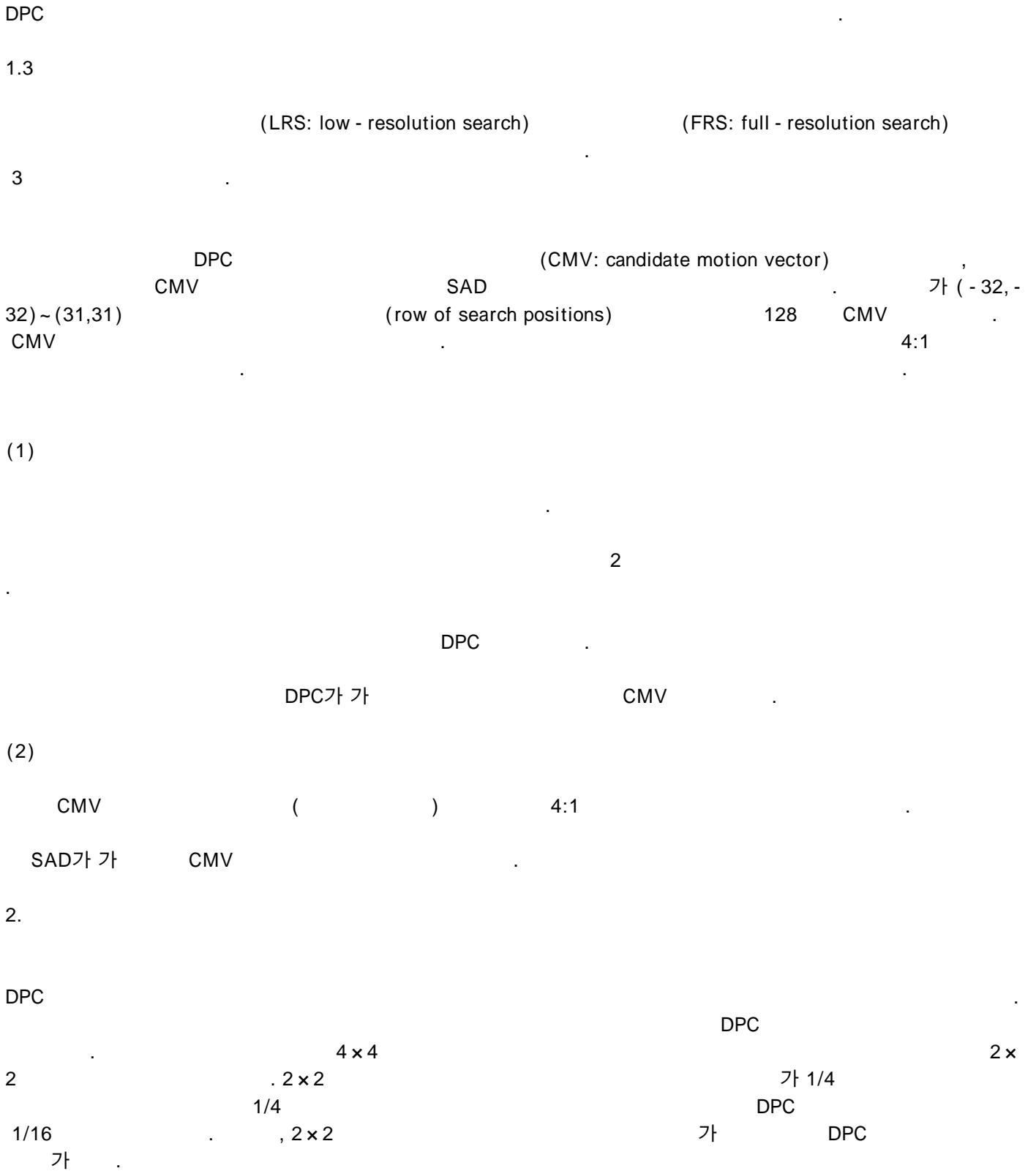

$\pm 64 \times \pm 64$

(1)  $2 \times 2$  , (3) DPC , (2) , (4) (ou  
 tsider pixel) (overload quantization error)가  
 otion estimation) (OPEME: outsider pixel exclusion m

2.1

가  
 pixel averaging) 가 . PSNR (1) (subsampling), (2) (  
 $2 \times 2$ )

2.2

가 . PSNR (1) (LSB truncation) , (2) 가  
 um mean absolute error quantization) (MMAE quantization: minim  
 m - , m, m+  
 가 가 ,

```
m = "calculate_mean(reference_block);
    = "32;
    = "16;
MAE_min = "calculate_MAE(m - , " m, m+ );
do {
MAE_1 = "calculate_MAE(m - ( - ), " m, m+( - ));
MAE_2 = "calculate_MAE(m - ( + ), " m, m+( + ));
if min(MAE_min , MAE_1, MAE_2) == "MAE_1) {
MAE_min = "MAE_1;
    = " - ;
} else if (MAE_min , MAE_1, MAE_2) == "MAE_2) {
MAE_min = "MAE_2;
```

```

    = " + ;
}
    = " /2;
} while ( != "1)

```

2.3

DPC

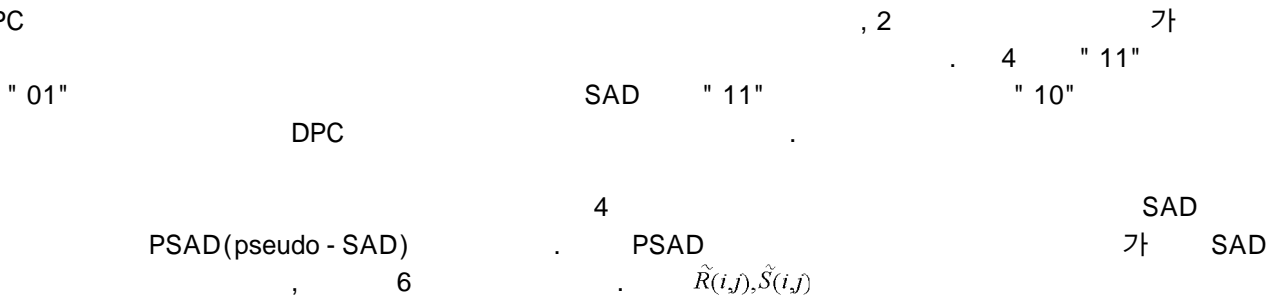

6

$$\langle PSTYLESPACE=100 \rangle PSAD(u,v) = \sum_{i=0}^{N-1} \sum_{j=0}^{M-1} |\hat{P}(i,j) - \hat{S}(i+u,j+v)|$$

[ 1 ]

	11	10	00	01
11	0	1	1	1
10	1	0	1	1
00	1	1	0	1
01	1	1	1	0

	11	10	00	01
11	0	1	2	3
10	1	0	1	2
00	2	1	0	1
01	3	2	1	0

(a) DPC

(b) PSAD

2 , DPC DPC PSAD 1 . PSAD 5 가  
100%

2.4

6 (a) (granular error) (overload error) 가 가

7 (a), (b) 가 가 7 (a) 가  
7 (b) 가

7 (c) (outsider pixel) 가  
(  $p_{min}$  ,  $p_{max}$  ) 가  
(  $p_{max} - m$  ) = "K(  $p_{ma$   
x - m), (  $m - p_{min}$  ) = "K(  $m - p_{min}$  ) , K = " (  $p_{max} - m$  ) / (  $p_{max} - m$  ) , m,  $p_{max}$  ,  $p_{min}$   
,  $S_{max}$  ,  $S_{min}$  ,

K가 가 가 가  
K가 가 K  
7 2 가 , K = " " K = " "  
, 7 PSNR 0.84 ~ 1.40 dB

2.5

S: low - resolution search) (FRS: full - resolution search) (LR  
2 x 2 가 PSAD (CMV  
set) , CMV CMV 4 SAD

(1)

2 × 2

2 × 2

2.2

m - , m, m+

( min , max )

2.2

2

PSAD

가

PSAD가 가

N

CMV

(2)

N CMV

4N

( , 2 × 2

) SAD

2 × 2

CMV

4

SAD가 가

3.

3.1

( - 32.0, - 32.0) ~ (31.5,31.5)

가 , MPEG2 MP@ML P -

MPEG2

가

8

3.1.1

9

(PPU: pre - processing unit, 200), 2

(DPC)

(CMV)

(LRS:low

- resolution search unit, 210), CMV

4:1

(IM

V: integer - pel motion vector)

(FRS: full - resolution search unit, 220),

, PPU, LRS, FRS, HPS

(230)

IMV

(HMV: half - pel motion vector

(HPS: half - pel search unit,

(200),

(210)

(220)

(200) (202) (204) (202)

E) ( max, min) (204) (Pmax) (Pmin) (MMA)

(212) (210) (212), (214) (216)

(204) 가 (214) 가

(216) (214)

가

(220)

(220) 8x8 SAD SAD 8x8 SAD (222) 16x16 SAD

16x16 SAD (224)

3.1.2

10

가

PSW ,  
NRB

CSW ,  
CRB ,

PRB ,

3.2

VLSI

11

2

2

1

16

16

(column) (= "16" )

DPC

2

가

3.3

CMV 16 × 16 SAD 8 × 8 SAD 4:1  
 VLSI 13 SAD 4:1

(57)

1.

(a)

(b)

(c) 가

(a)

(a - 1) 가 (MAE) (MMAE)

(a - 2)

2.

1 (c)

(c - 1) (a) (b) 가

(c - 2)

(c - 3) (c - 2) 가가

3.

1 2

8 , 2 .

4.

1 2 , (a)

;

MAE) 가 가 (MAE) ; (M

;

5.

4 ,

2x2 .

6.

1 2 , (b)

7.

1 ,

8.

(a) ; ,

(b) ;

(c) 가 , 가 ,

(a)

(a - 1) ;

(a - 2) (Pmax) (Pmin) ( max, m  
in) ;

(a - 3)

(b) (c)

9.

8 (c)

(c - 1) (a) (b) 가  
( ) ;

(c - 2)

(c - 3) (c - 2) 가 가

10.

8 9 ,

8 , 2

11.

8 9 , (a)

(Pmax) (Pmin) ( max, min)

12.

11 ,

2x2

13.

8 9 , (b)

14.

1 , (a)

(a - 1) 가 가 (MAE) ; (MMAE)

(a - 2) (Pmax) (Pmin) ( max, m in) ;

(a - 3)

(b) (c)

15.

14 , (c)

(c - 1) (a) (b) 가 ( ) ;

(c - 2)

(c - 3) (c - 2) 가가

16.

14 15 ,

8 , 2

17.

14 15 , (a)

;



21.

;

가

가

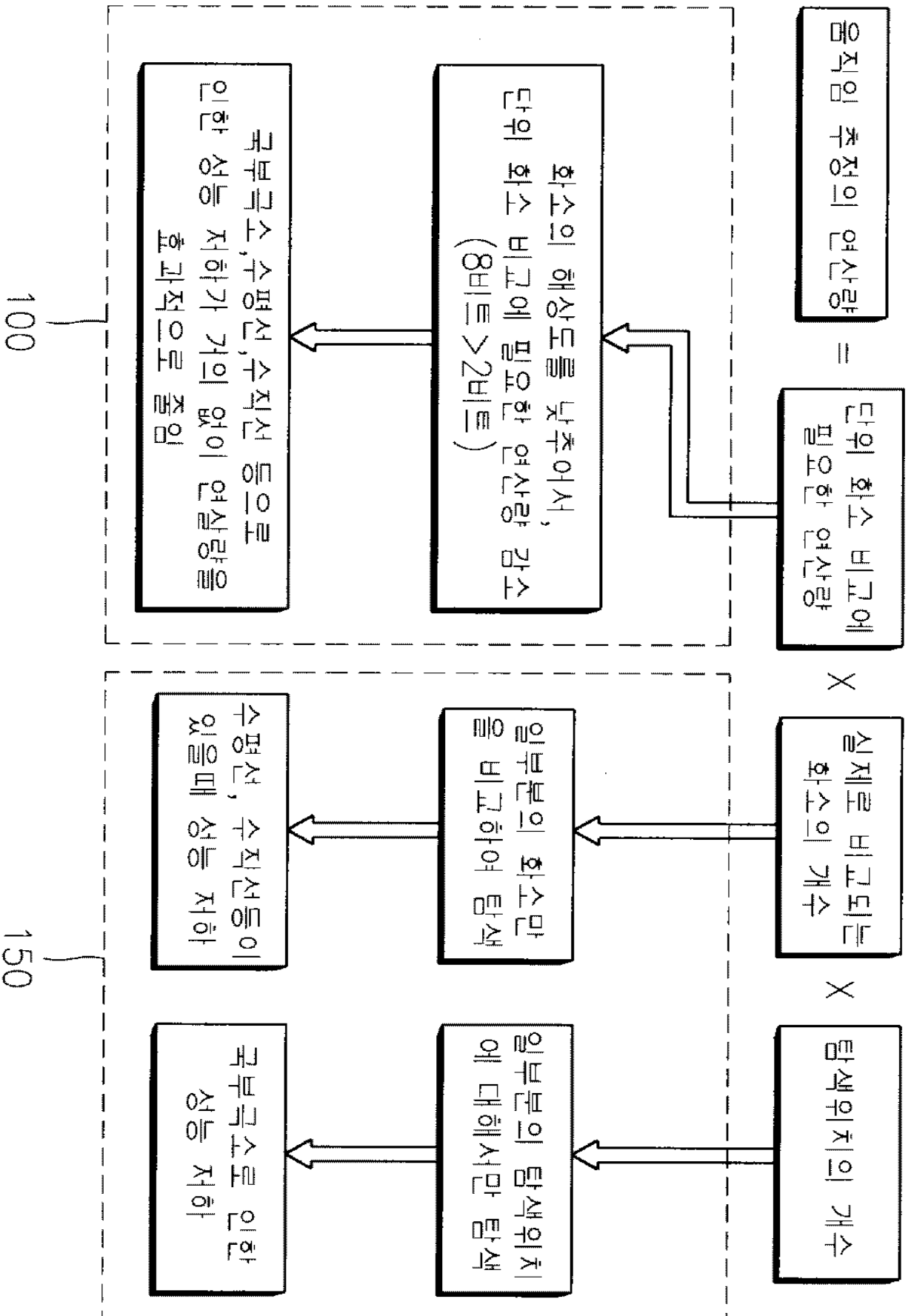

2

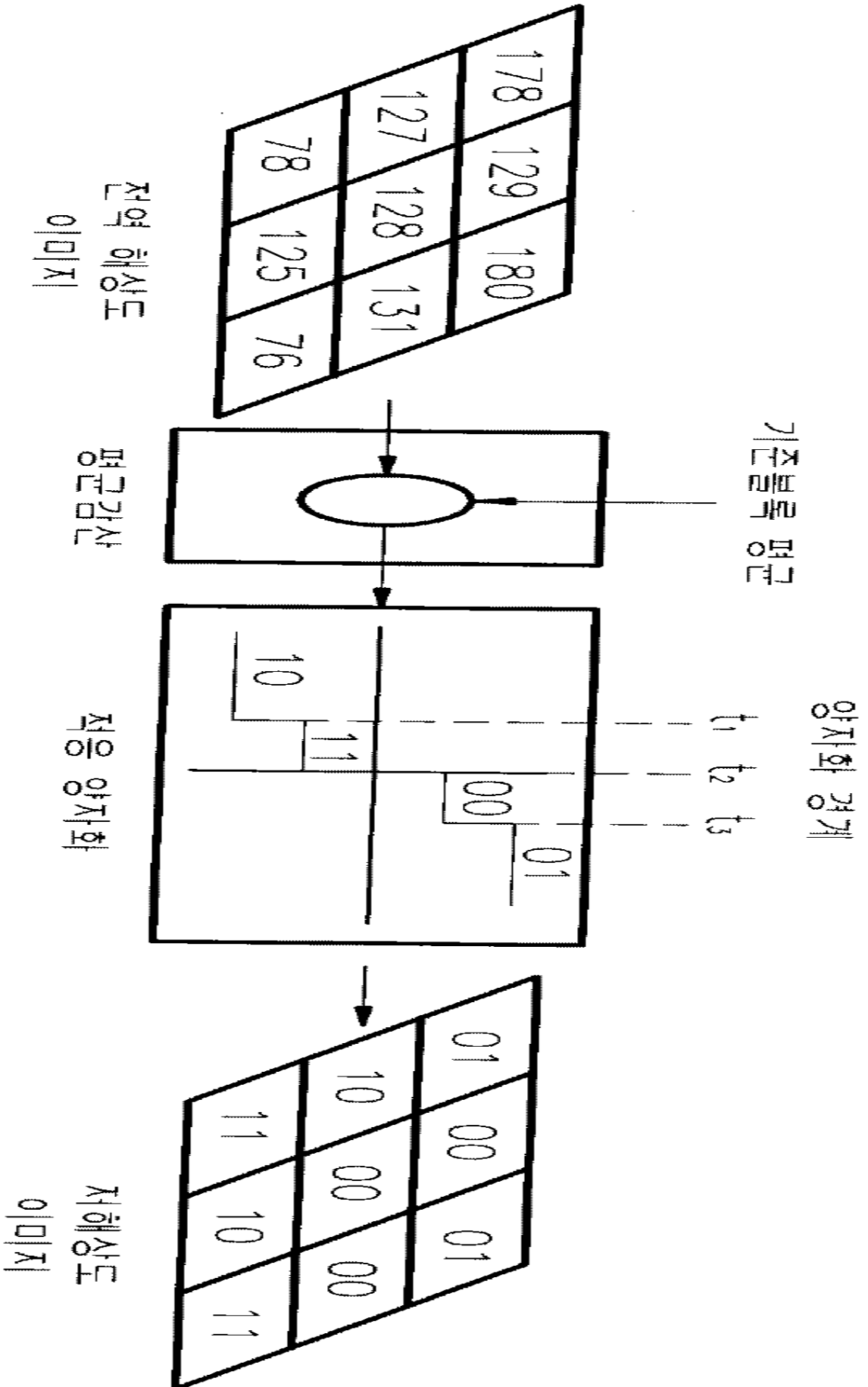

저해상도 탐색(LRS)

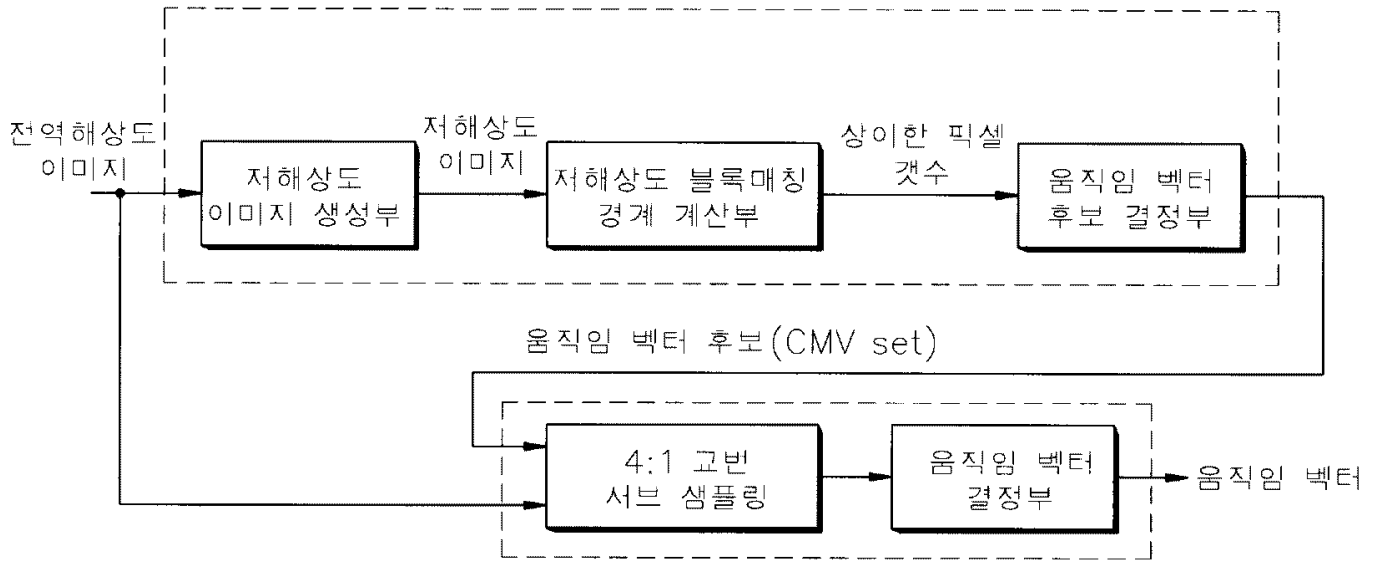

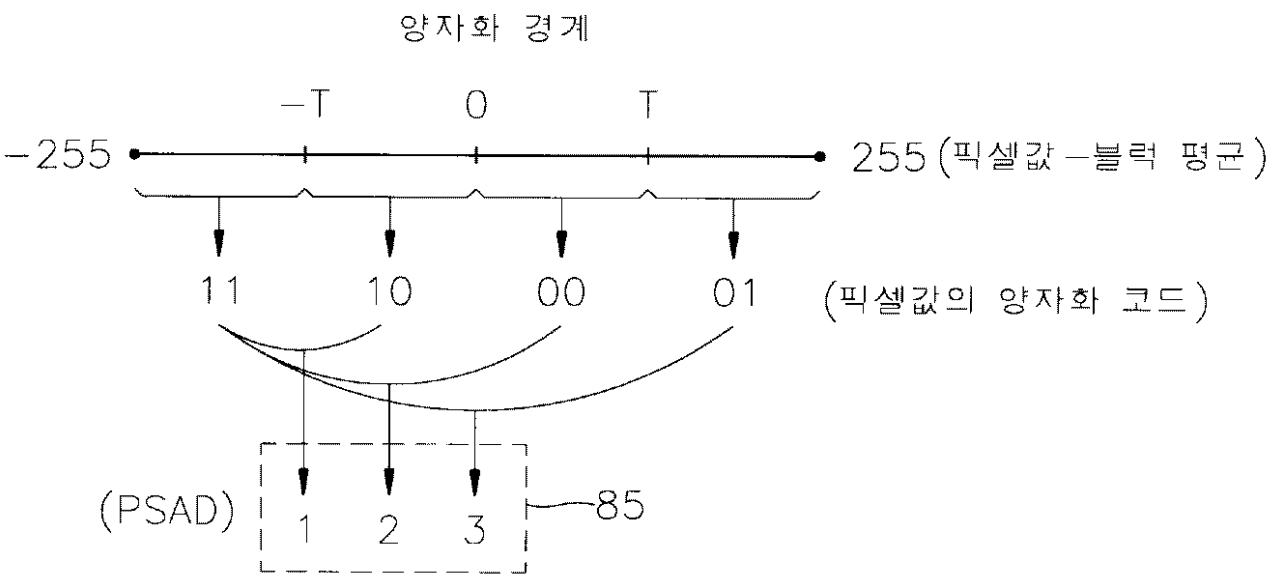
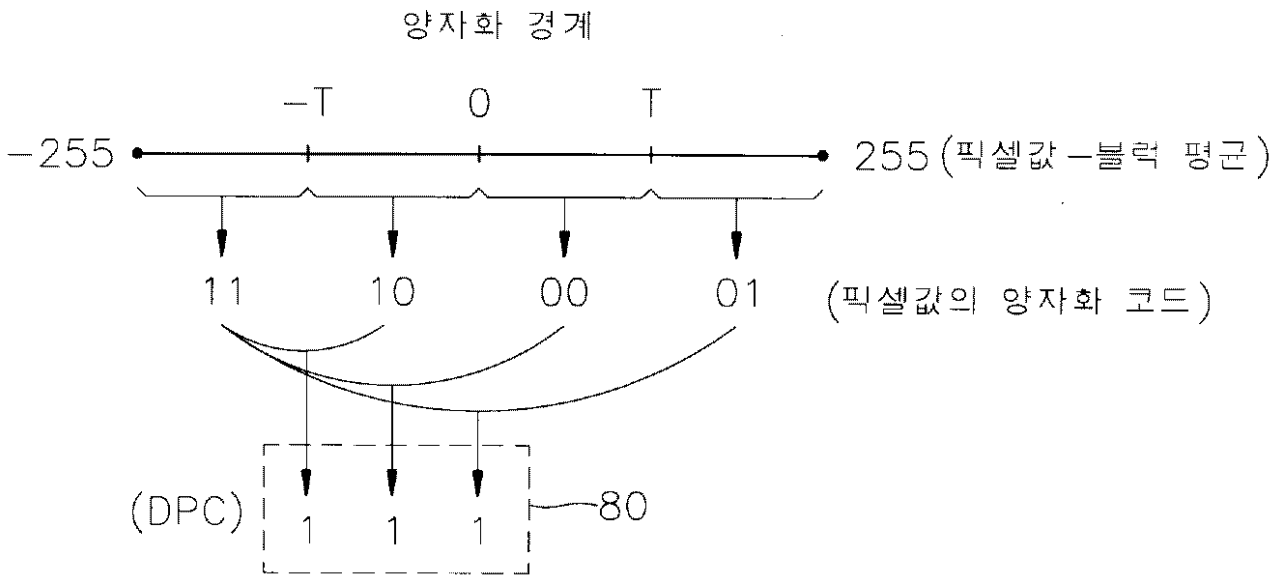

5

- : 탐색 윈도우 픽셀 데이터
- : 기준 블록 픽셀 데이터

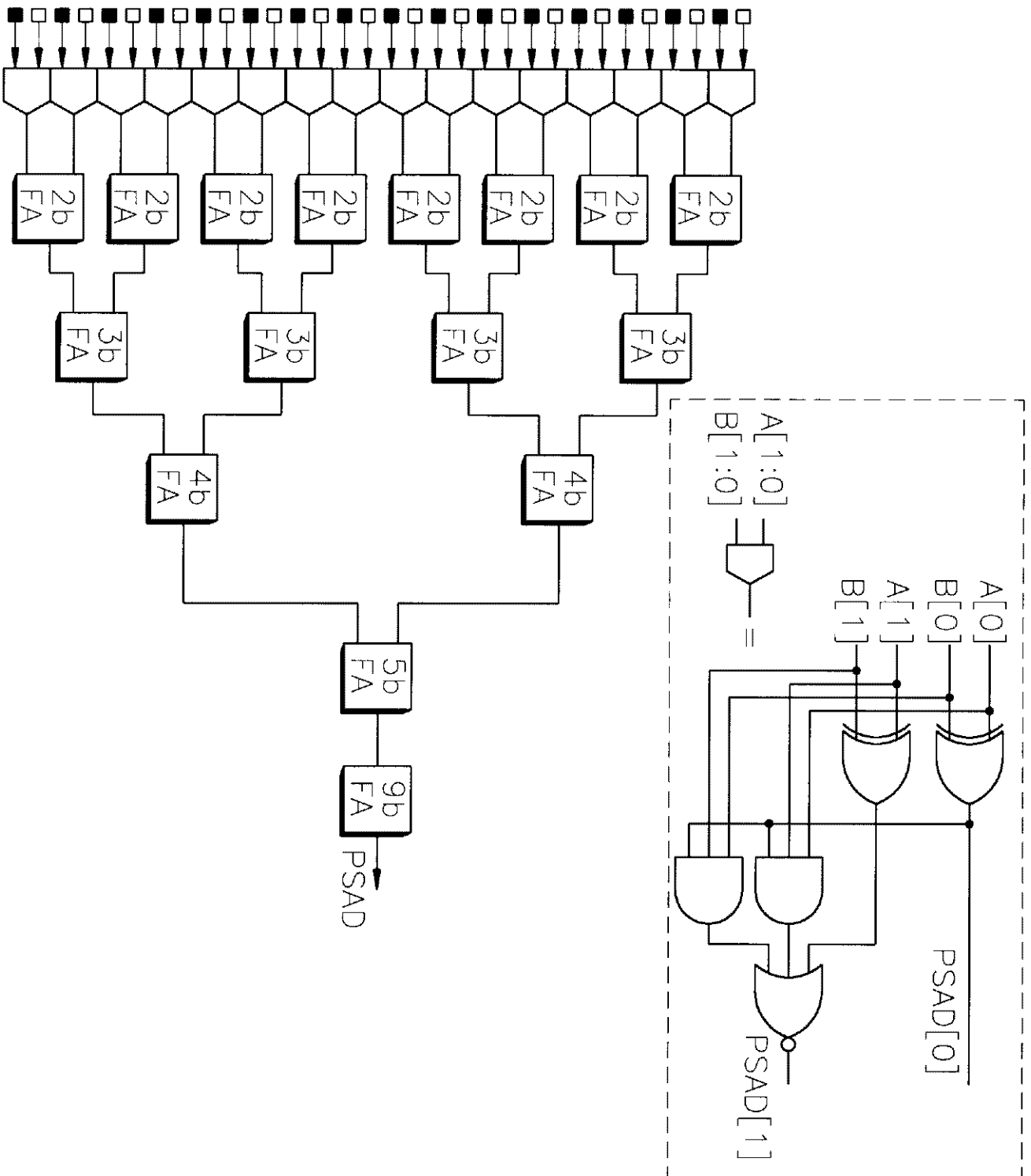

(a)

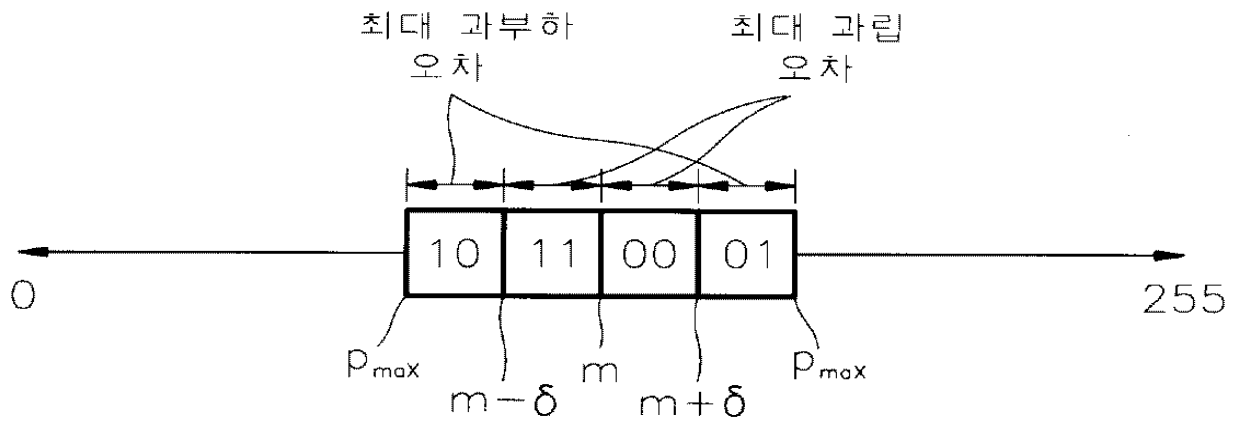

(b)

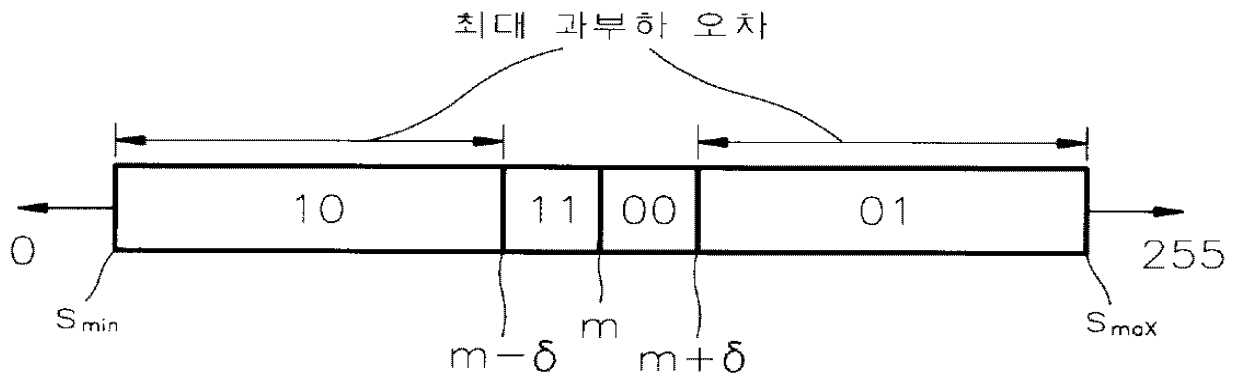

(c)

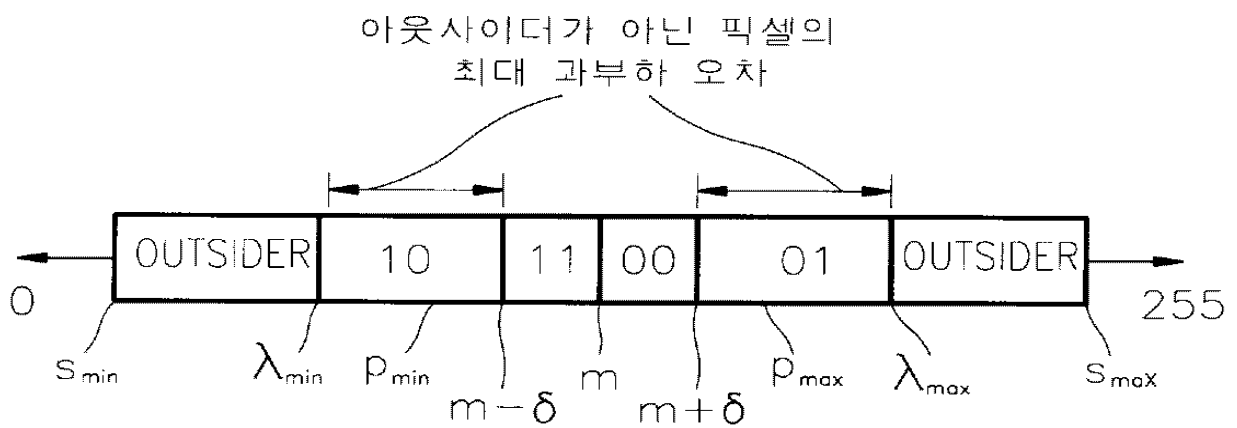

7

(a)

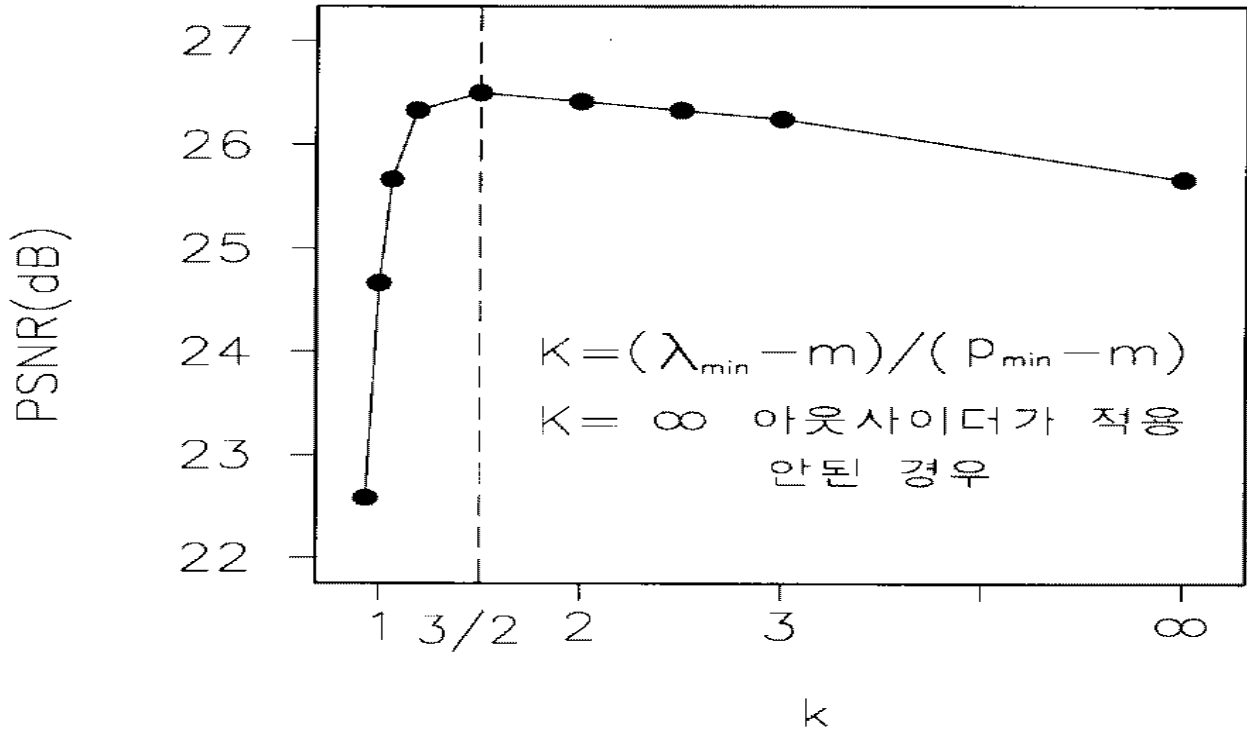

(b)

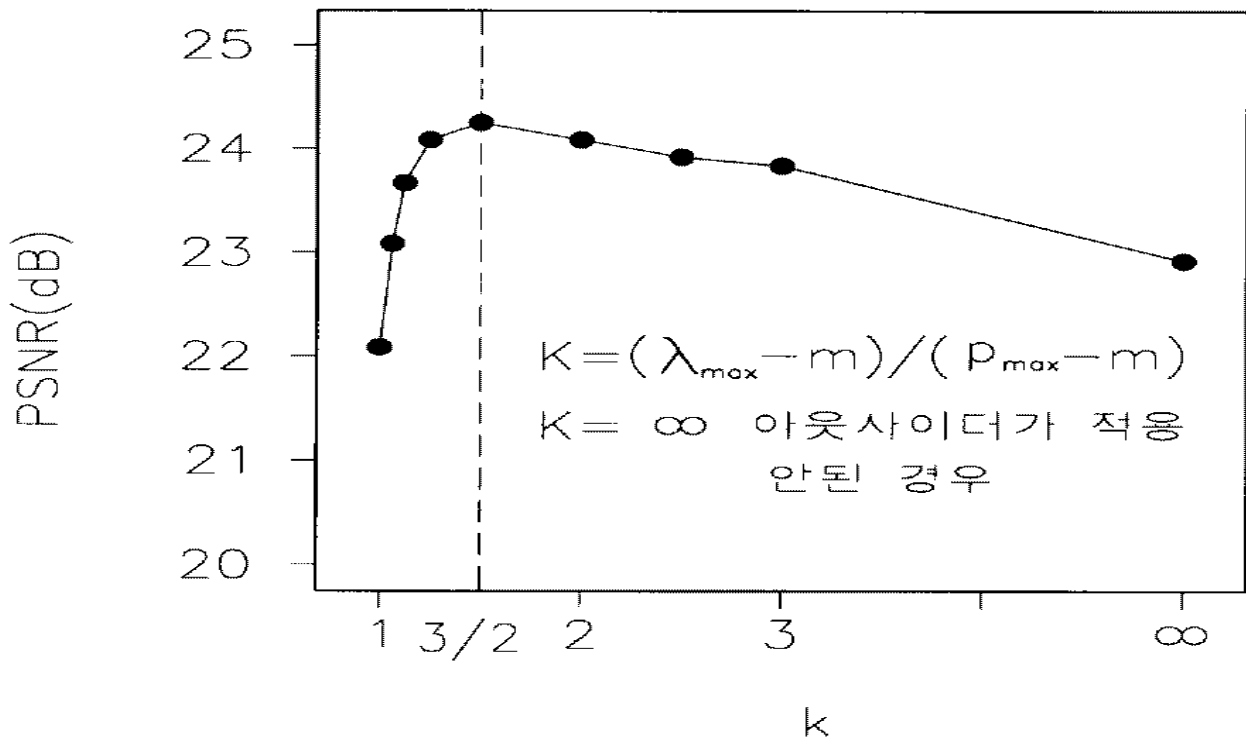

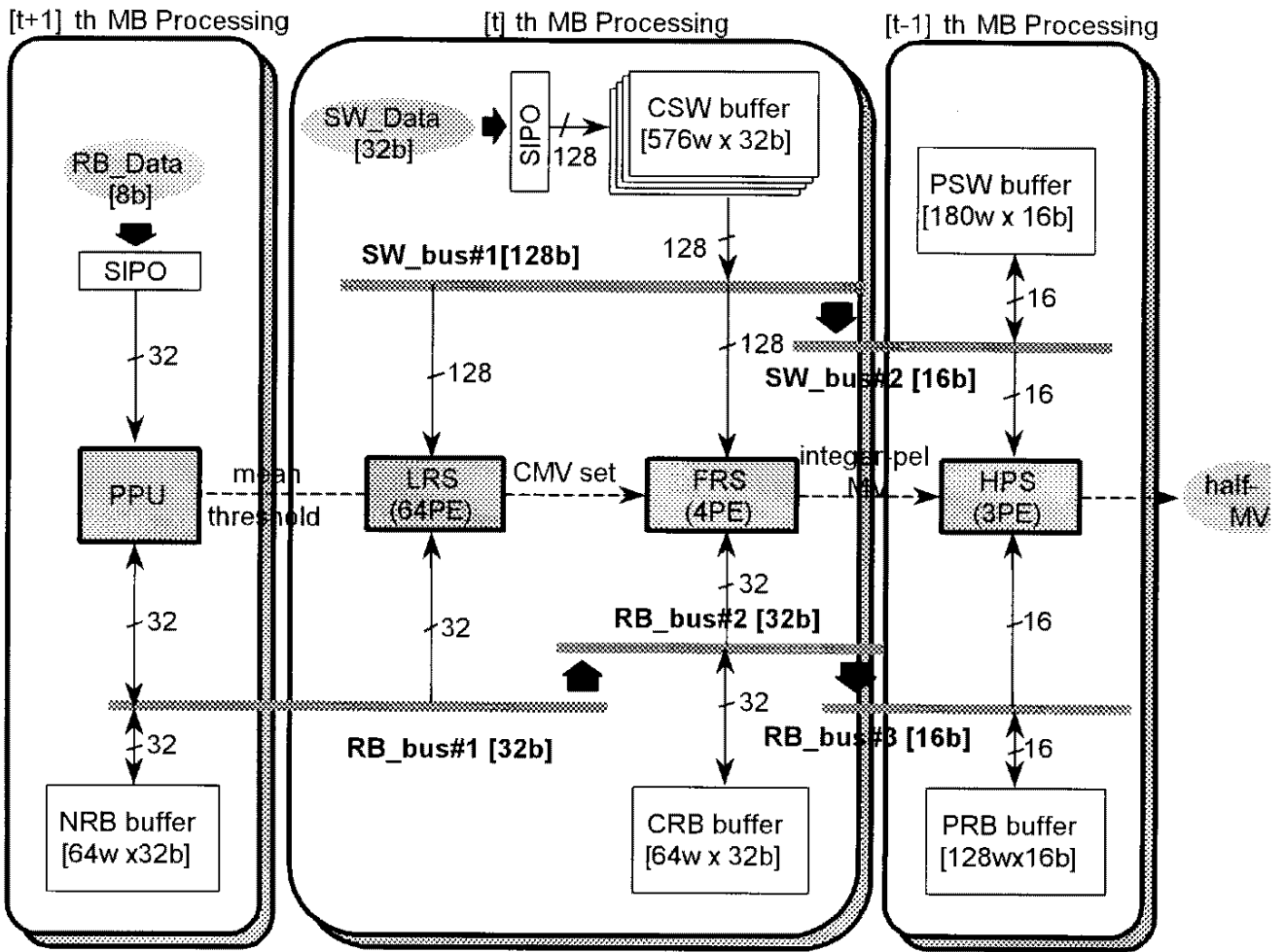

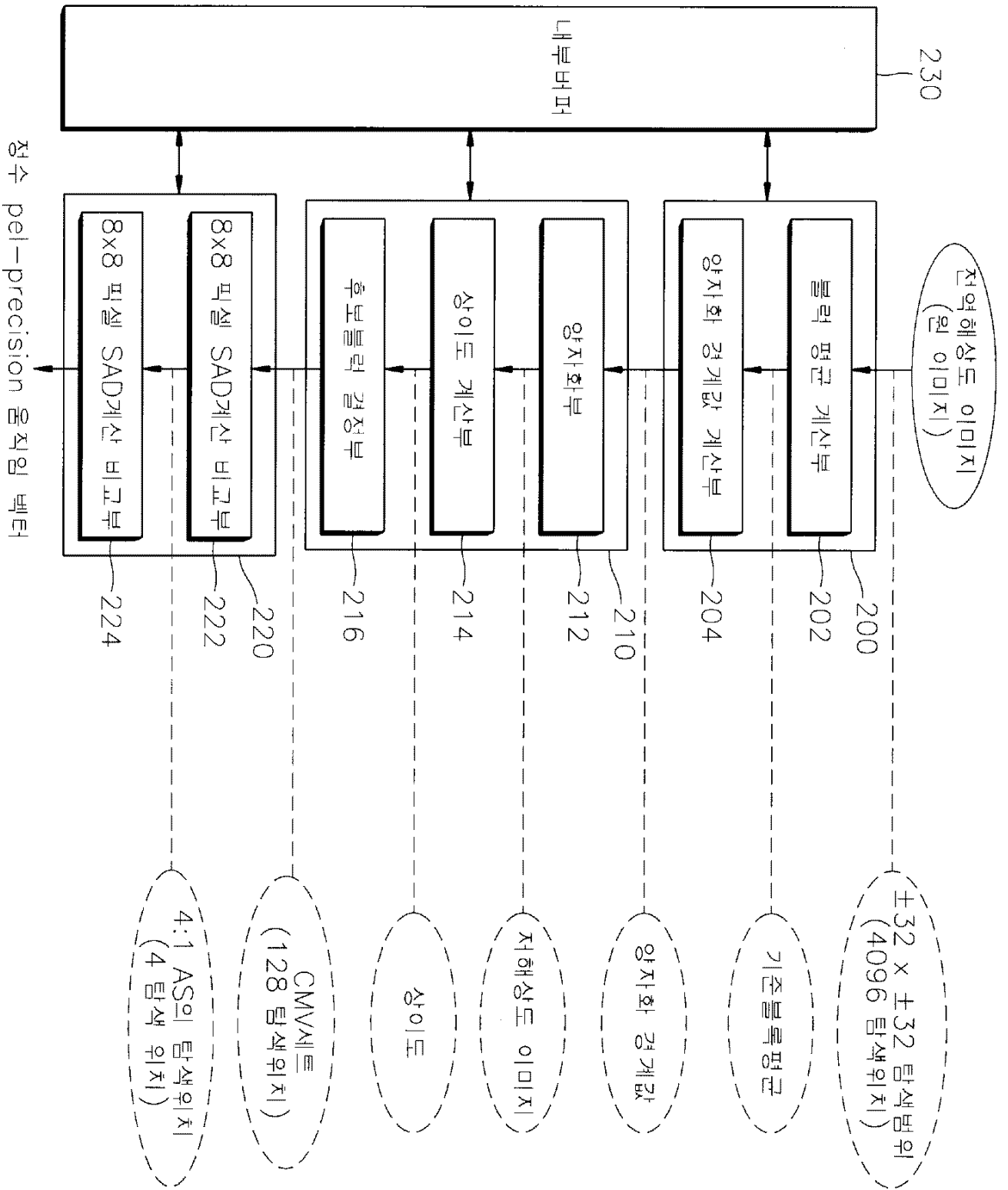

10

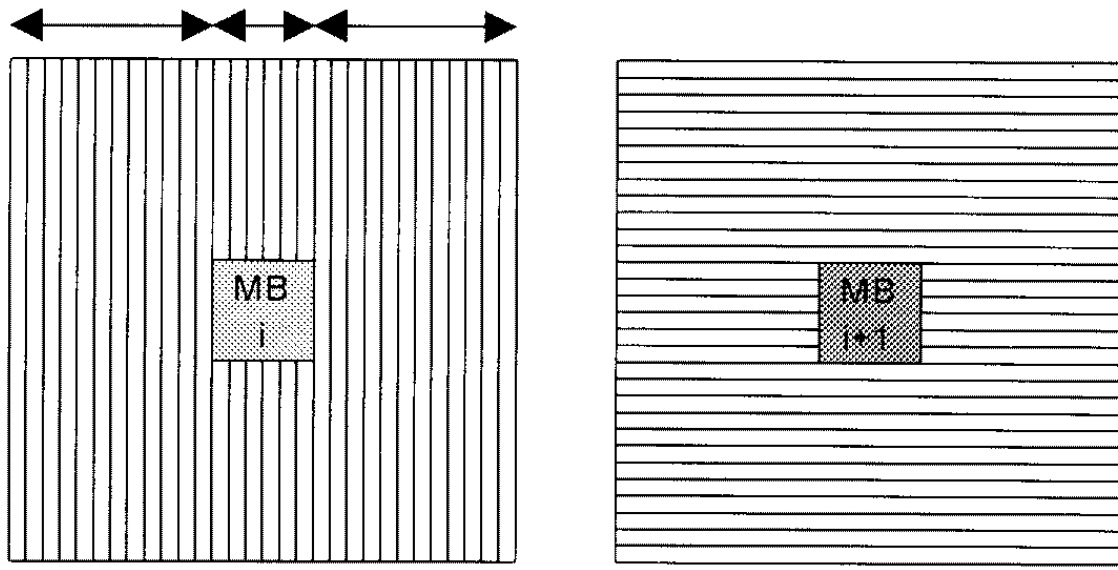

search window  
for  $i$ -th MB

search window  
for  $(i+1)$ -th MB

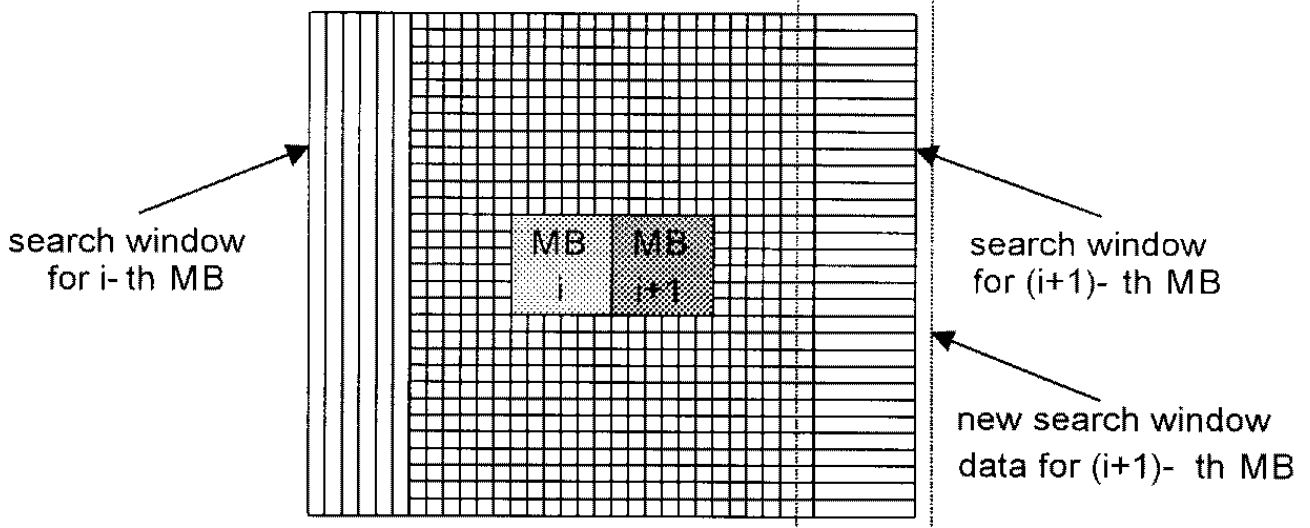
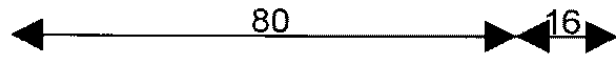
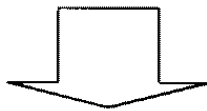

search window  
for  $i$ -th MB

search window  
for  $(i+1)$ -th MB

new search window  
data for  $(i+1)$ -th MB

11

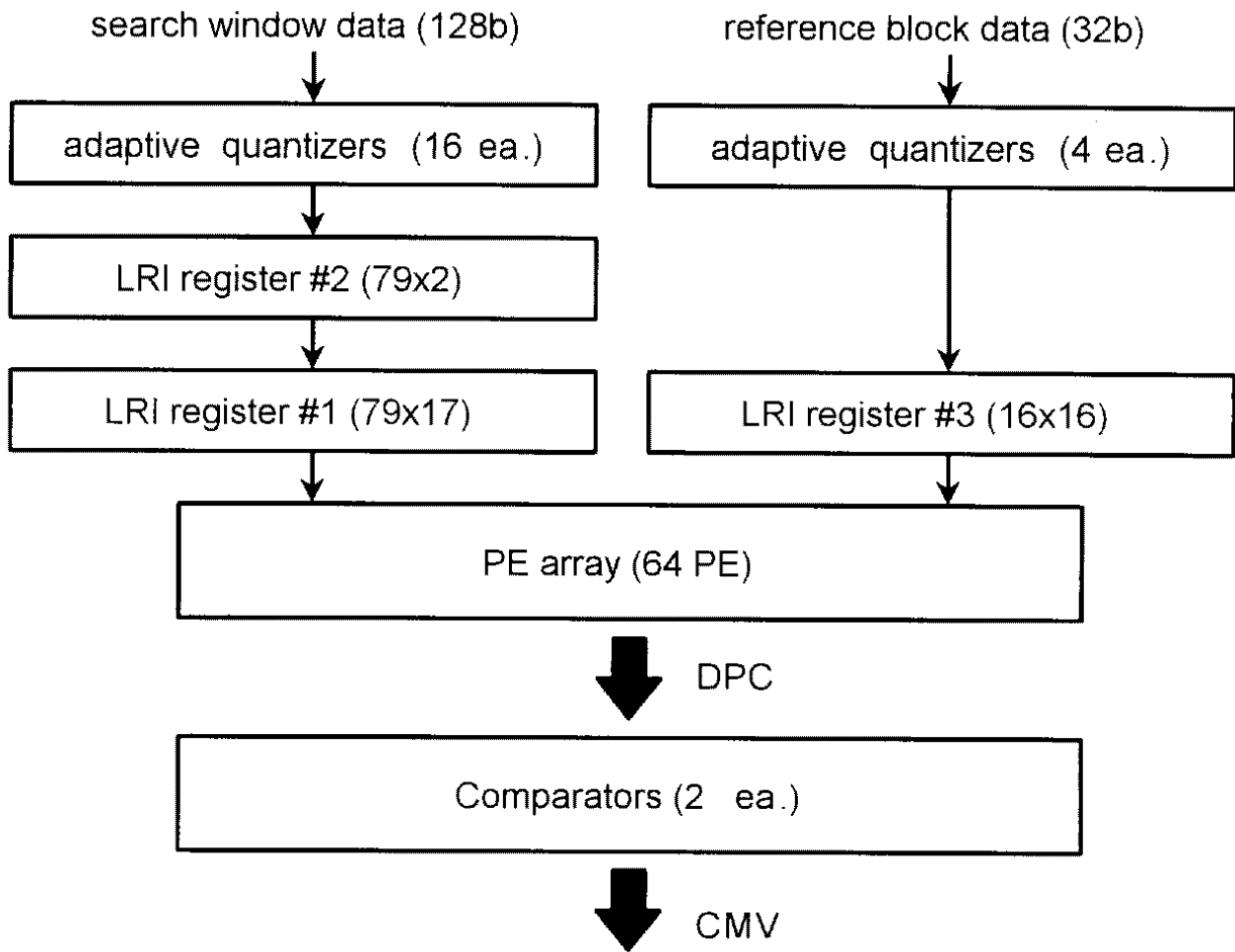

12

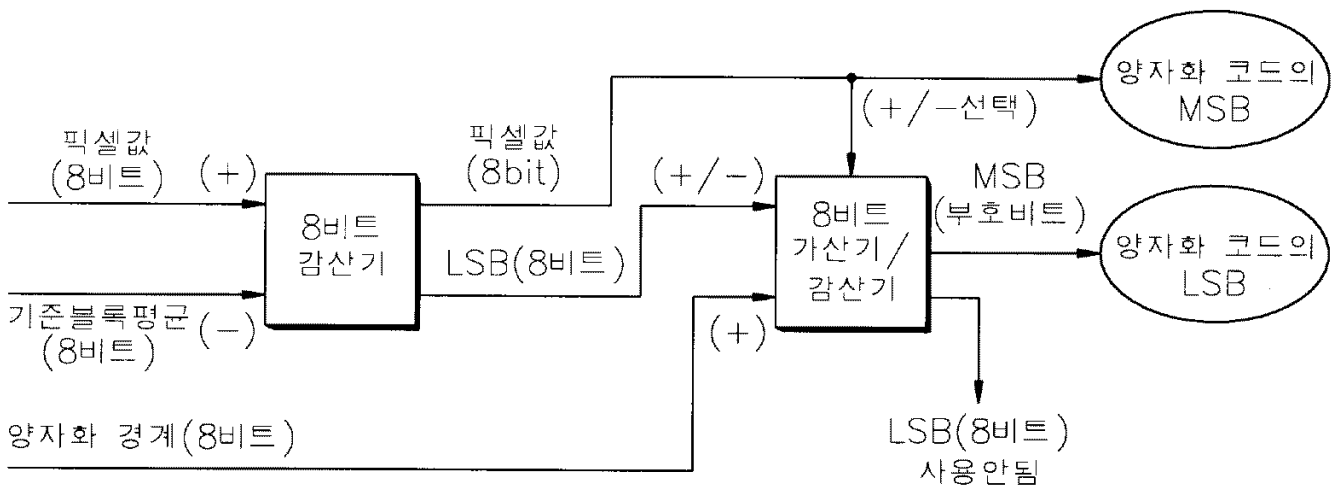

13

