



(19) **United States**
(12) **Patent Application Publication**
Lawson et al.

(10) **Pub. No.: US 2012/0020808 A1**
(43) **Pub. Date: Jan. 26, 2012**

(54) **WIRELESS MONITORING OF PUMP JACK
SUCKER ROD LOADING AND POSITION**

Publication Classification

(76) Inventors: **Rick A. Lawson**, Spring, TX (US);
Paul N. Katz, Bellaire, TX (US)

(51) **Int. Cl.**
F04B 49/20 (2006.01)
E21B 47/00 (2012.01)

(21) Appl. No.: **13/262,189**

(52) **U.S. Cl.** **417/18; 73/152.61**

(22) PCT Filed: **Mar. 31, 2010**

(57) **ABSTRACT**

(86) PCT No.: **PCT/US10/29453**

§ 371 (c)(1),
(2), (4) Date: **Sep. 29, 2011**

Forces on and respective positions of a pump jack sucker rod are determined in real time by load cells attached to the sucker rod and a position sensor, and are stored for further processing. A wireless transmitter transmits stored load and position values, calculated process parameters, and/or exception alerts to a wireless spread spectrum receiver that can be coupled to a motor speed controller used to set the rotational speed of the pump jack motor, and/or to monitoring systems, such as a central controller used to optimize total field production.

Related U.S. Application Data

(60) Provisional application No. 61/165,628, filed on Apr. 1, 2009.

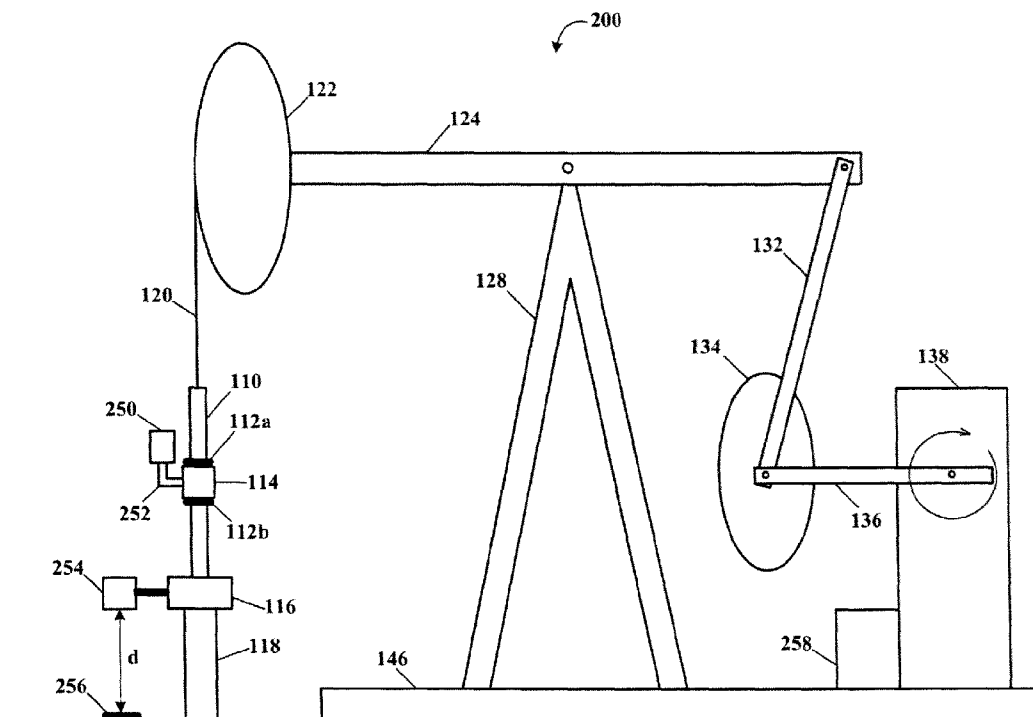

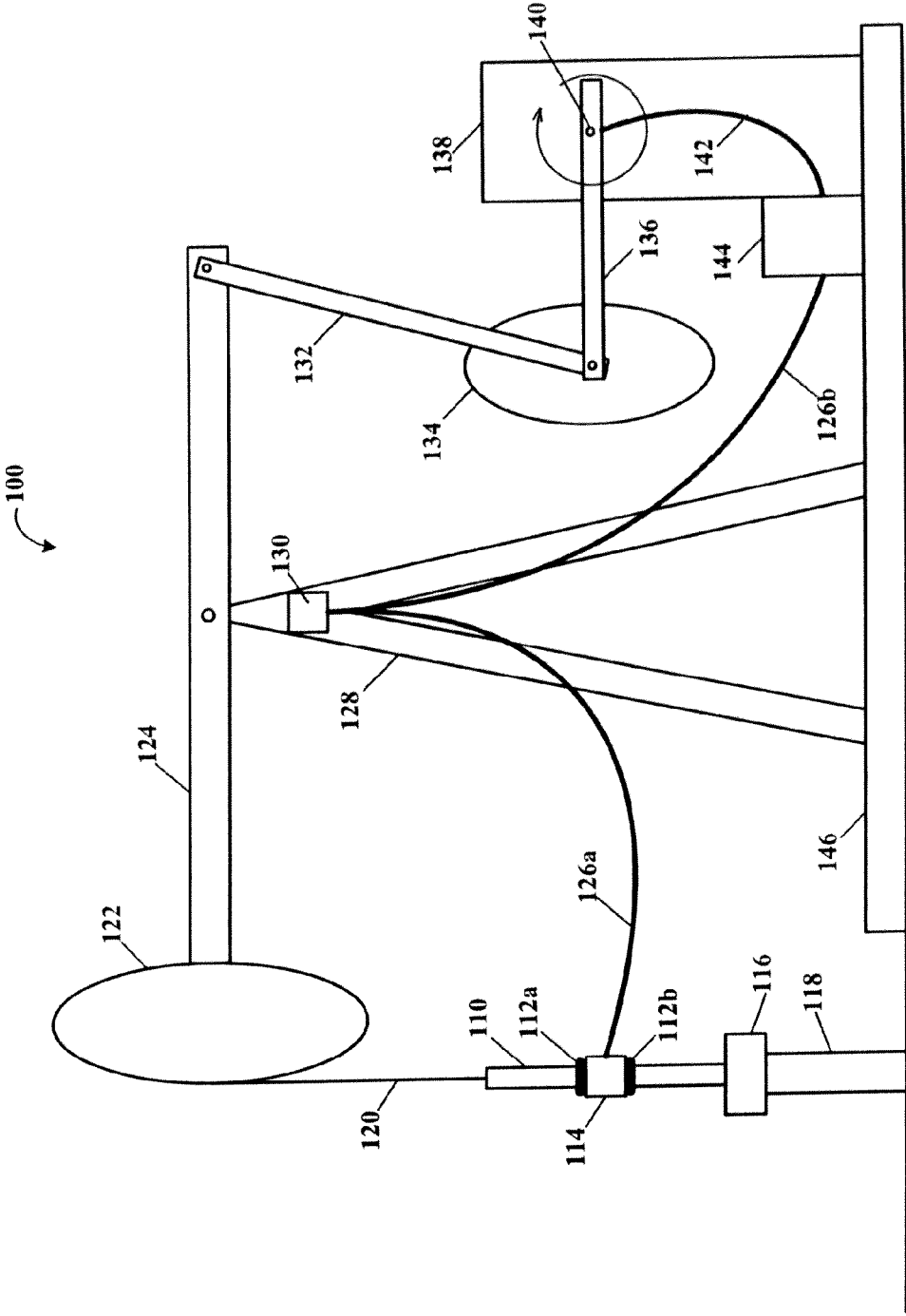

FIGURE 1 (Prior Technology)

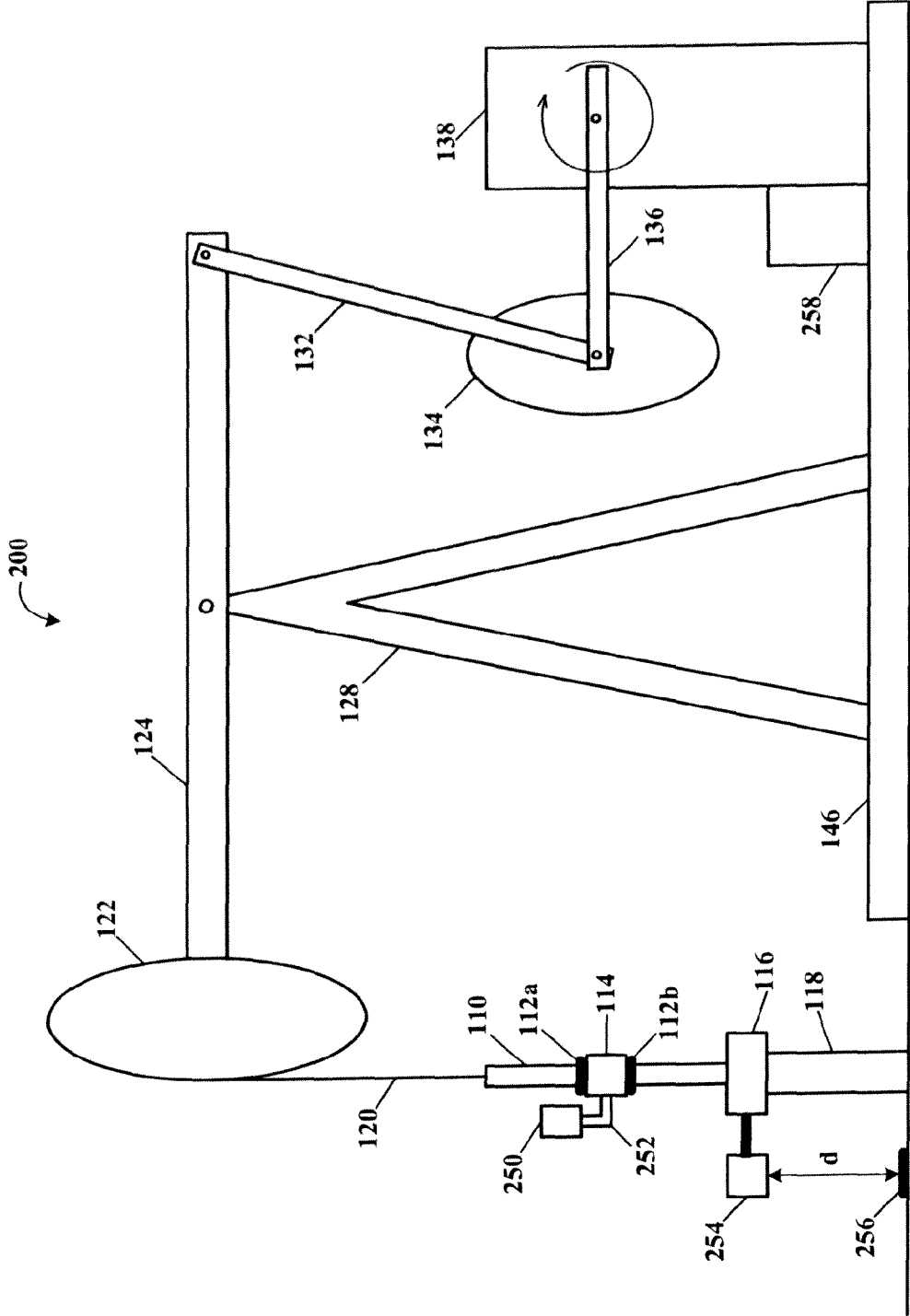

FIGURE 2

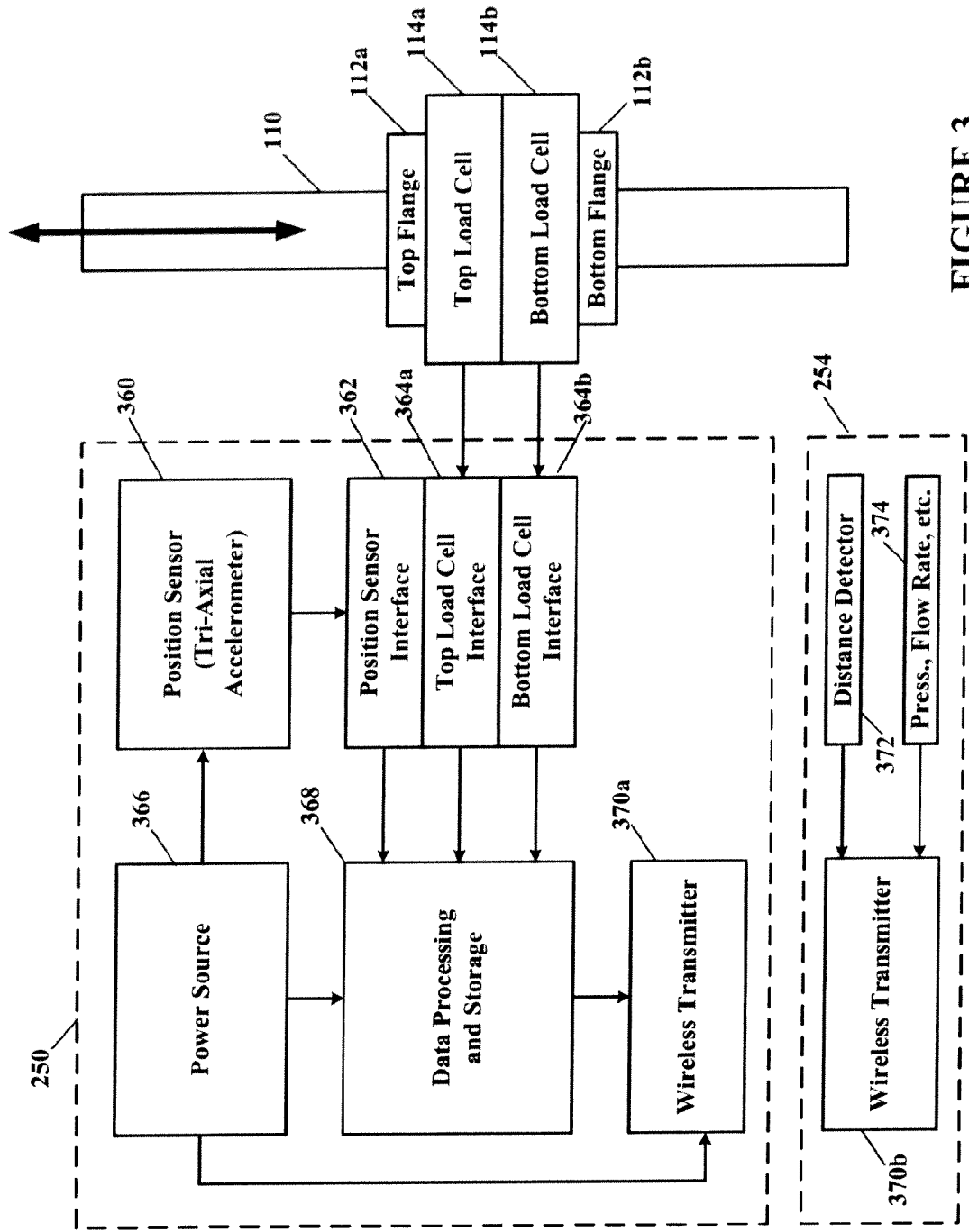

FIGURE 3

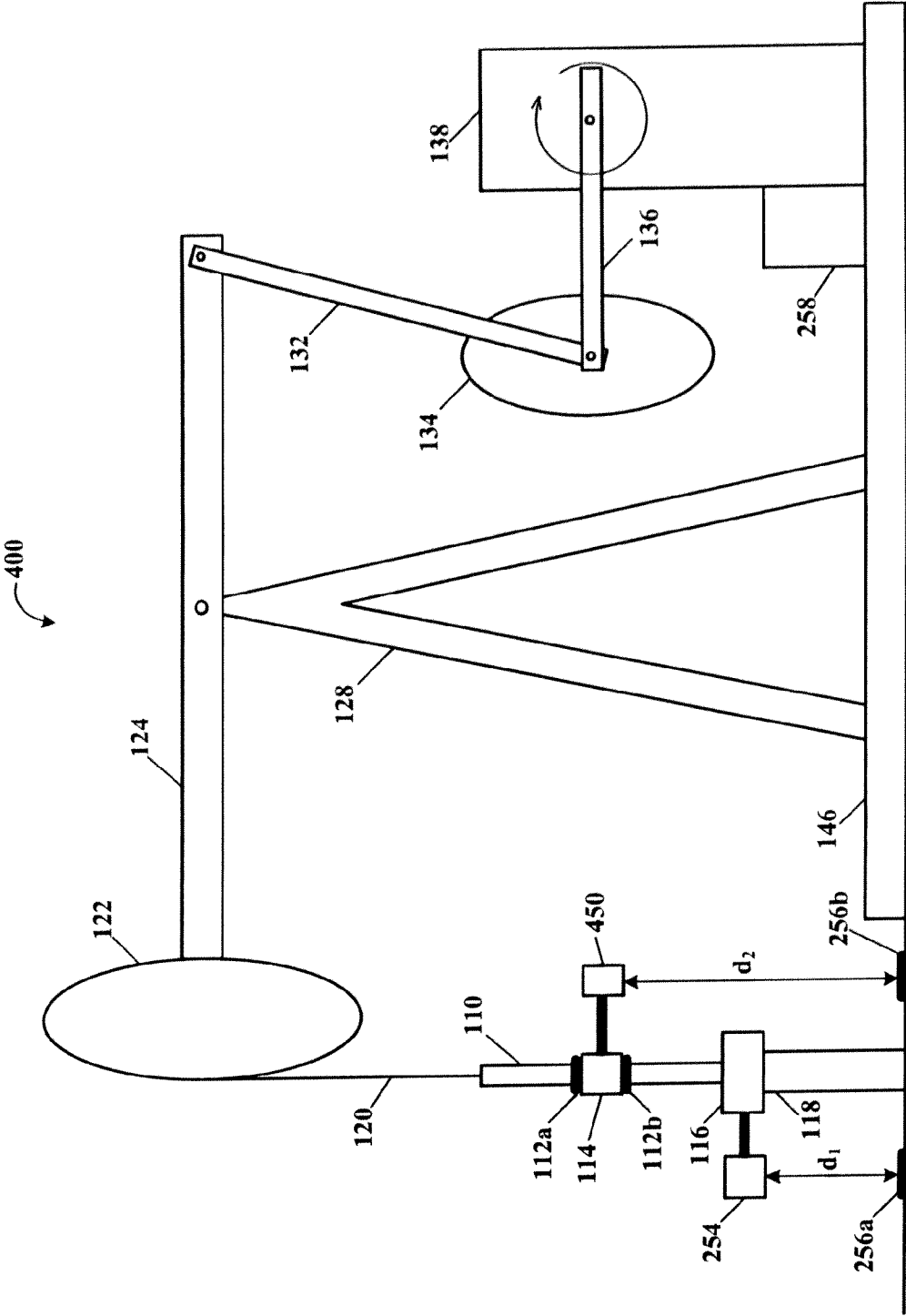

FIGURE 4

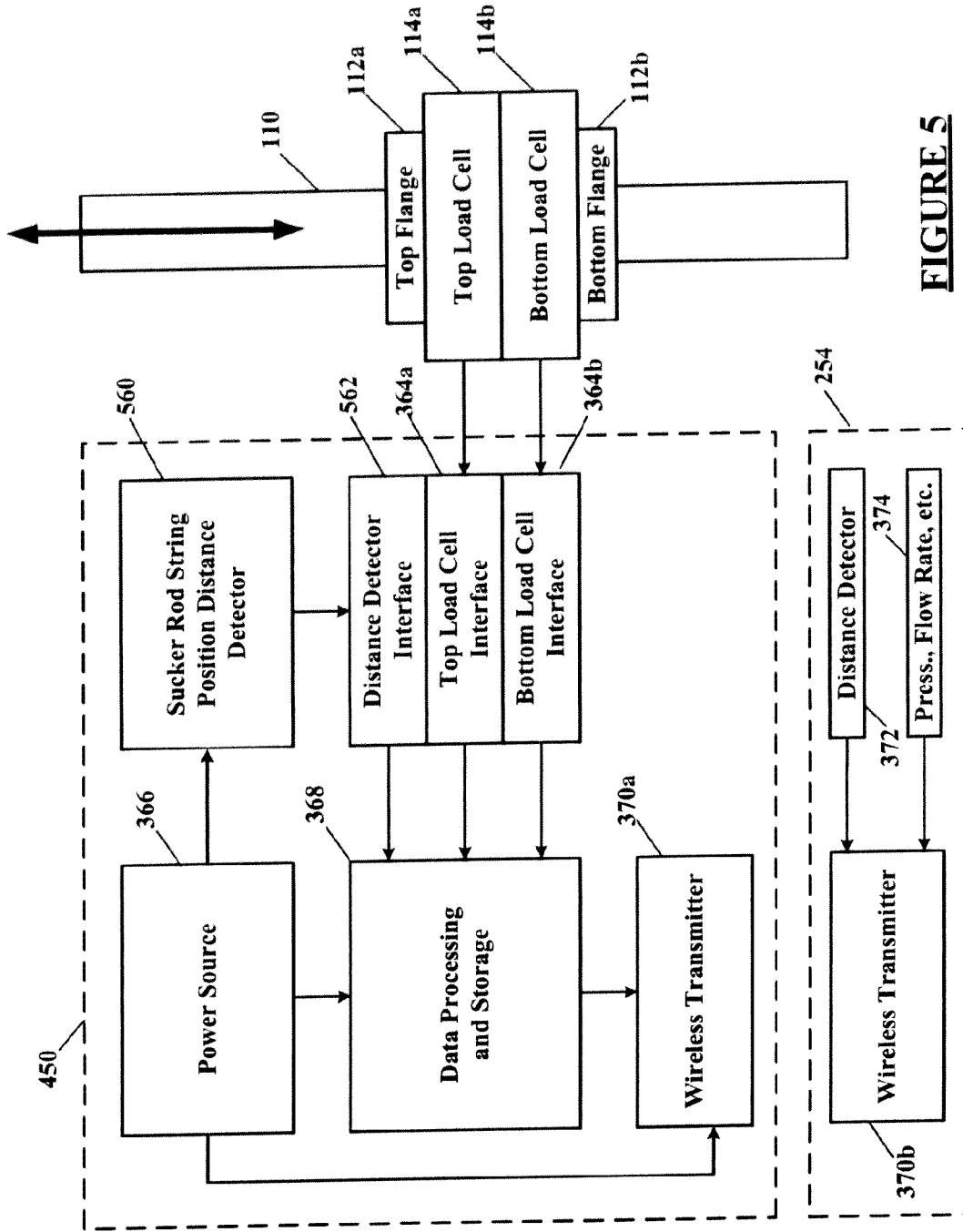

FIGURE 5

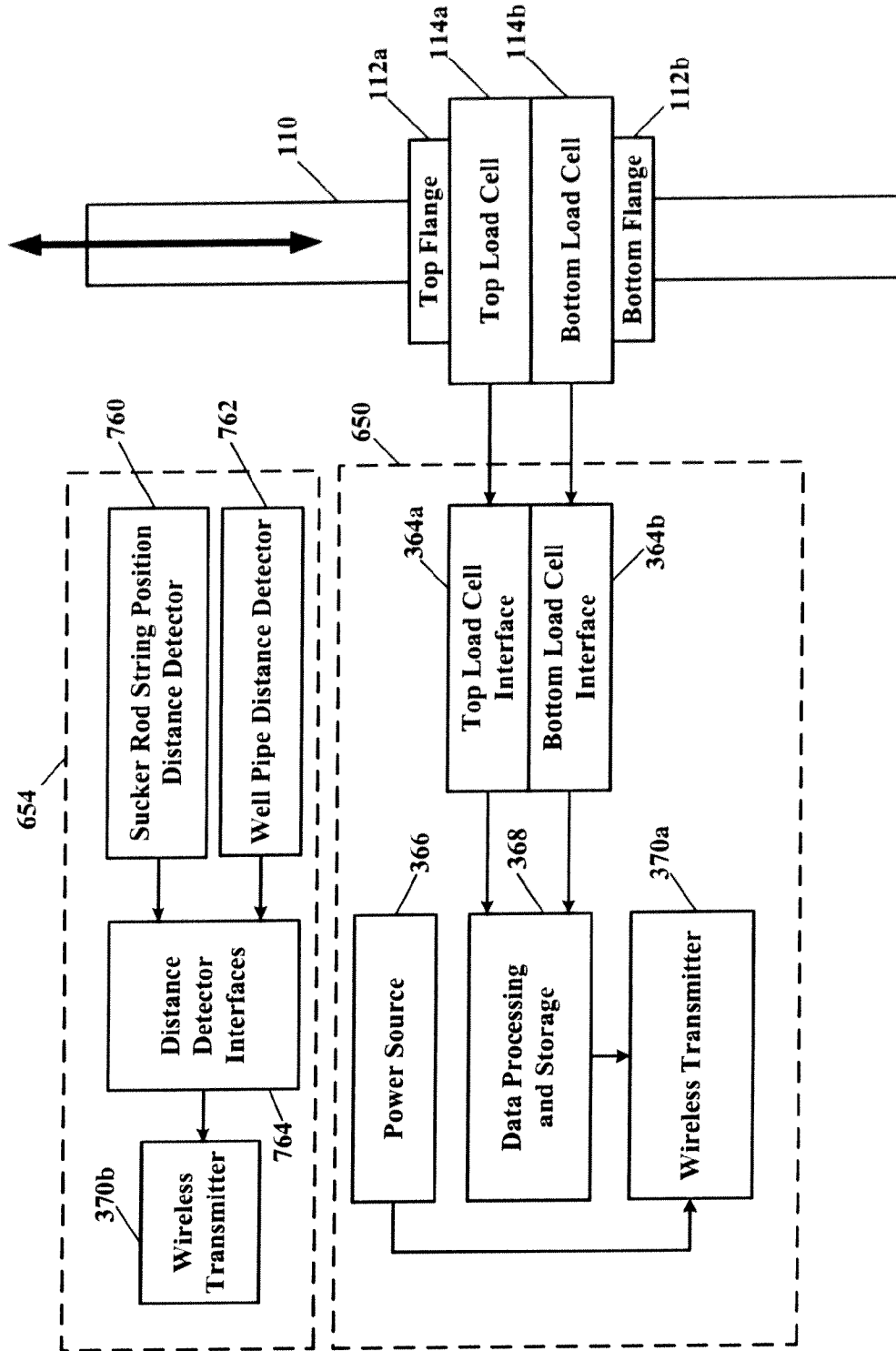

FIGURE 7

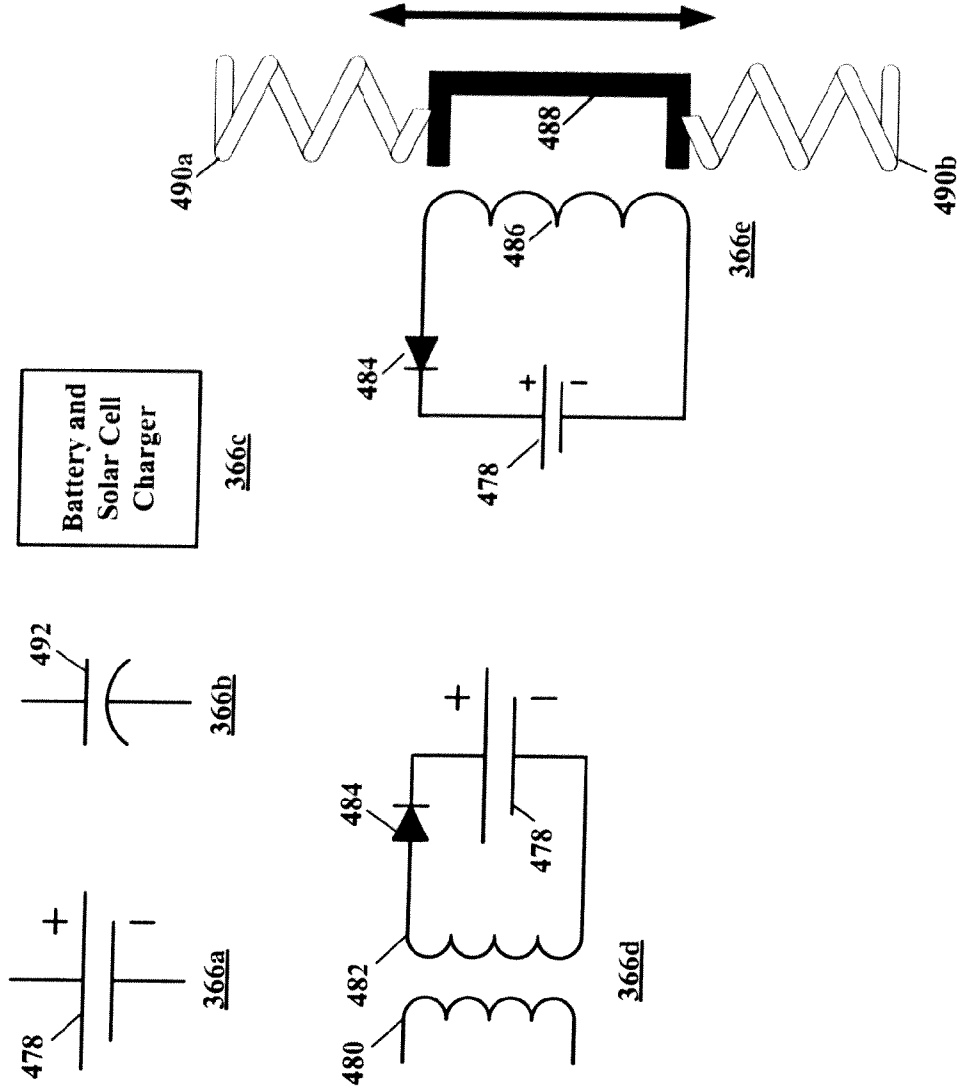

FIGURE 8

WIRELESS MONITORING OF PUMP JACK SUCKER ROD LOADING AND POSITION

RELATED PATENT APPLICATION

[0001] This application claims priority to commonly owned U.S. Provisional Patent Application Ser. No. 61/165,628; filed Apr. 1, 2009; entitled “Wireless Monitoring Of Pump Jack Sucker Rod Loading And Position,” by Rick A. Lawson and Doneil Dorado; and is hereby incorporated by reference herein for all purposes.

TECHNICAL FIELD

[0002] The present disclosure relates to oil well pump jacks and, more particularly, to monitoring and control of the pump jacks to optimize pumping operation of the pump jacks in producing production from the oil wells.

BACKGROUND

[0003] Historically, oil wells which must produce by artificial lift have used horsehead-type pumping units such as those made by Lufkin Industries and others. To counterbalance the weight of the sucker rod string, counterweights are used, either mounted on the walking beam or a rotary-type mounted on the gear box Pittman arm. Another class of pumping unit (also made by Lufkin) uses an air cylinder in place of the metal counterweights. The effect is roughly the same. The sucker rod string reciprocates up and down in a sine wave motion caused by rotation of the Pittman arm by an electric motor.

[0004] The electric motor drives the pumping jack sucker rod string on as to lift oil in discreet slugs or pulses from a pocket at the bottom of the well bore to the surface. Such a pumping system typically comprises a power driven jack or beam which reciprocates on a pivot to reciprocate a string of well (sucker) rod up and down in the well casing, and thereby provide a lifting or pumping action that delivers the crude oil and brine from the well pocket to the well head at the surface and thereafter storage.

[0005] The rate at which the crude oil in an oil well migrates to the well bore and fills the well pocket may vary widely from one well to another depending upon specific geologic conditions in the oil bearing sands, and the age of the oil field in terms of the proportion of recoverable crude oil which has been removed from the geologic formations. In mature wells, commonly known as stripper wells, the maximum attainable production rate will depend entirely on how quickly the spontaneous migration of crude oil to the well pocket can fill the pocket. Typically, in such wells the pumping capacity of the pumping jack is far greater than the capacity of the field to refill well pocket with crude oil from the oil bearing formations. Even in newer, more productive wells the pumping capacity of the pumping jack may far exceed spontaneous well pocket refill rates.

[0006] To accommodate these well pocket refill rates and other limitations of oil well production, the rotational speed of the electric motor is controlled so as to optimize fluid pumping action by the well sucker rod string of the pumping jack, so that pumping action is not too fast or too slow.

[0007] A pump motor speed controller is used to control the pumping action of the pump jack from various parameters of the pump jack. For example, the well sucker rod string load (up and down) and rotational speed of the pump motor may be

used in determining optimal pumping action, and/or to alert for undesirable conditions in the well.

[0008] FIG. 1 illustrates a schematic elevational diagram of a prior technology pump jack system having hardwired sucker rod load and position sensors, and connected to a well sucker rod string. The pump jack system, represented by the numeral 100, comprises a sucker rod string 110, a polish rod 120, a horsehead 122, a rocker beam 124, connecting rod 132, counter weight 134, Pittman arm 136, motor/gear drive 138, frame 128 and base 146. As the motor/gear drive 138 rotates, the Pittman arm 136 causes the connecting rod 132 to push up or pull down one end of the rocker beam 124. On the other end of the rocker beam 124 is the horsehead 122 connected to the polish rod 120. As the horsehead 122 moves up and down so does the polish rod 120 which in turn moves the sucker rod string 110 in and out of the well bore pipe 118. The well bore pipe 118 is terminated at flange/fluid takeoff assembly 116 that is adapted to allow fluid (or gas) being pumped out of the well bore pipe 118 to flow to a storage tank/pipeline (not shown). The flange/fluid takeoff assembly 116 also is used to seal around a portion of the sucker rod string 110 so that well fluid does not spill onto the ground.

[0009] Axial forces on the sucker rod string 110 may be measured by a load cell 114 that determines the axial forces applied to the sucker rod string 110 when being draw upwards and when being pushed downward. The load cell 114 accomplishes these measurements by being held in a fixed position on the sucker rod string 110 between a top clamp collar 112a and a bottom clamp collar 112b.

[0010] The vertical position of the sucker rod string 110 relative to the down hole well pocket may be determined by positional information from a rotation position sensor 140, e.g., Hall effect device, that indicates the rotational position of the Pittman arm 136. The vertical position of the sucker rod string 110 may then be correlated with the rotational position of the Pittman arm 136. Once the sucker rod string 110 axial forces and associated vertical positions are available, a determination can be made for a desired rotational speed(s) of the motor/gear drive 138 to optimize well fluid pumping action. Note that the rotational speed can be varied during a pumping cycle (360 degree rotation of the Pittman arm 136) to further optimize the well fluid pumping action.

[0011] The load cell 114 may be electrically coupled to a motor speed controller 144 through a flexible electrical cable 126 that may be attached to the frame 128 with a junction/strain relief box 130. The rotation position sensor 140 may be electrically coupled to the motor speed controller 144 through an electrical conduit or cable 142. The electrical cable 126 may be routed over the horsehead 122 and across the rocker beam 124.

[0012] Flexibility of the electrical cable 126 is very important in that the load cell 114 is constantly moving up and down. However this constant flexing of the electrical cable 126 causes failures thereto that requires maintenance and replacement in the field. Also the rotation position sensor 140 is subject to failure and also requires periodic maintenance and/or replacement. Working in close proximity to the Pittman arm 136 when servicing the rotation position sensor 140 poses serious safety issues and careless field service technicians have been injured, some severely, by coming in contact with a Pittman arm 136 that accidentally starts to rotate while service/replacement of the position sensor 140 is being performed. Thus, service, reliability and safety problems exist in present technology load and position measurement installa-

tions and servicing of pump jack systems, specifically for fatigue of the connecting electrical cables and the hazards of accidental rotation of machinery while servicing sensors in close proximity thereto.

SUMMARY

[0013] Therefore a need exists to overcome the above-identified problems as well as other shortcomings and deficiencies of existing technologies by providing wireless transmission of data from sucker rod load and position sensors, and then using that data to control the pump jack system operating parameters so as to optimize fluid lift from the well pocket.

[0014] According to the teachings of this disclosure, a wireless sensor package is mechanically and electrically attached to the load cell **114**, and moves therewith. The wireless sensor package comprises an electrical interface for receiving electrical signals from the load cell **114**, and a position sensor, e.g., a tri-axial accelerometer, or device for measuring distance from a fixed point, e.g., ultrasonic, radio frequency, infrared, laser light, etc. In addition, a downhole temperature gradient may be determined by measurement of the elongation of the well bore pipe **118** projecting out of the ground (e.g., distance from ground level to the top of the well bore pipe **118**). Well pressure and flow rate may also be measured at the flange/fluid takeoff assembly **116**.

[0015] The wireless sensor package is adapted to transmit the sucker rod load and position information over a radio frequency channel(s), e.g., short-range radio, for example but not limited to, frequencies at about 315 MHz, 433 MHz, 868 MHz, 902 to 928 MHz, 2.4 to 2.5 GHz, 5.7 to 5.8 GHz, etc. In addition, any form of transmission and modulation techniques may be used, for example but not limited to, spread spectrum to a compatible receive, e.g., spread spectrum receiver, coupled to a motor speed controller. Computations for optimal motor speeds from the wireless load and position data may be performed in the wireless sensor package and/or the wireless motor speed controller. A central controller receiving load and position information and/or motor speeds from each of the plurality of pump jacks may further be used to control pump speeds of the plurality of pump jacks so as to optimize oil field production, e.g., flow rates of pumped product. The central controller may also determine optimal pumping parameters of each of the plurality of pump jacks so as to maximize oil field production.

[0016] According to a specific example embodiment of this disclosure, a pump jack adapted for monitoring sucker rod load and position comprises: a sucker rod string in a well bore pipe; a polished rod coupled to the sucker rod string; a horsehead coupled to the polished rod; a rocker beam coupled to the horsehead; a connecting rod coupled to the rocker beam; a counter weight coupled to the connecting rod; a pittman arm coupled to the connecting rod and counter weight; a variable speed motor-gear drive assembly coupled to the pittman arm for rotational movement thereof; a frame pivotally coupled to the rocker beam; a base attached to the frame; first and second force sensors attached to a proximate end of the sucker rod string, wherein the first and second force sensors measure elongation and compression stresses, respectively, of the sucker rod string while the sucker rod string moves up and down in the well bore pipe; a position sensor attached toward the proximate end of the sucker rod string, wherein the position sensor determines positions of the sucker rod string; a sensor interface assembly having wireless transmitting capabilities, wherein the sensor interface assembly is attached to

the sucker rod string, and is coupled to the first and second force measurement sensors and the position sensor, whereby the sucker rod string forces and position information are wirelessly transmitted therefrom; and a wireless receiver coupled to the variable speed motor-gear drive assembly, wherein the wireless receiver receives the force and position information transmitted from the interface assembly for determining control of rotational speed of the variable speed motor-gear drive assembly.

[0017] According to another specific example embodiment of this disclosure, an apparatus for monitoring position and load of a sucker rod in a pump jack, comprises: first and second force sensors attached at a proximate end of a sucker rod string of a pump jack, wherein the first and second force sensors measure elongation and compression stresses, respectively, of the sucker rod string while the sucker rod string moves up and down in a well bore pipe; a position sensor attached toward the proximate end of the sucker rod string, wherein the position sensor determines positions of the sucker rod string; and a sensor interface assembly having wireless transmitting capabilities, wherein the sensor interface assembly is attached to the sucker rod string, and is coupled to the first and second force measurement sensors and the position sensor, whereby the sucker rod string forces and position information are wirelessly transmitted therefrom.

[0018] According to still another specific example embodiment of this disclosure, a pump jack adapted for monitoring sucker rod load and position comprises: a sucker rod string in a well bore pipe; a polished rod coupled to the sucker rod string; a horsehead coupled to the polished rod; a rocker beam coupled to the horsehead; a connecting rod coupled to the rocker beam; a counter weight coupled to the connecting rod; a pittman arm coupled to the connecting rod and counter weight; a variable speed motor-gear drive assembly coupled to the pittman arm for rotational movement thereof; a frame pivotally coupled to the rocker beam; a base attached to the frame; first and second force sensors attached to a proximate end of the sucker rod string, wherein the first and second force sensors measure elongation and compression stresses, respectively, of the sucker rod string while the sucker rod string moves up and down in the well bore pipe; a sensor interface assembly having wireless transmitting capabilities, wherein the sensor interface assembly is attached to the sucker rod string, and is coupled to the first and second force measurement sensors, whereby the sucker rod string force information is wirelessly transmitted therefrom; a distance measuring device attached on a plan of the base and under the sensor interface assembly, wherein the position sensor determines positions of the sucker rod string by measuring distances between the distance measuring device and the sensor interface assembly; and a wireless receiver coupled to the variable speed motor-gear drive assembly, wherein the wireless receiver receives the force information transmitted from the sensor interface assembly, and wherein position information from the distance measuring device is coupled to the variable speed motor-gear drive assembly, whereby control of rotational speed of the variable speed motor-gear drive assembly is determined from the force and position information.

[0019] According to yet another specific example embodiment of this disclosure, an apparatus for monitoring position and load of a sucker rod in a pump jack comprises: first and second force sensors attached at a proximate end of a sucker

rod string of a pump jack, wherein the first and second force sensors measure elongation and compression stresses, respectively, of the sucker rod string while the sucker rod string moves up and down in a well bore pipe; a sensor interface assembly having wireless transmitting capabilities, wherein the sensor interface assembly is attached to the sucker rod string, and is coupled to the first and second force measurement sensors, whereby the sucker rod string force information is wirelessly transmitted therefrom; a distance measuring device attached on a plane of a base of the pump jack and under the sensor interface assembly, wherein the distance measuring device determines positions of the sucker rod string by measuring distances between the distance measuring device and the sensor interface assembly; and a wireless receiver coupled to the variable speed motor-gear drive assembly, wherein the wireless receiver receives the force information transmitted from the sensor interface assembly, and wherein position information from the distance measuring device is coupled to the variable speed motor-gear drive assembly, whereby control of rotational speed of the variable speed motor-gear drive assembly is determined from the force and position information.

BRIEF DESCRIPTION OF THE DRAWINGS

[0020] A more complete understanding of the present disclosure thereof may be acquired by referring to the following description taken in conjunction with the accompanying drawings wherein:

[0021] FIG. 1 illustrates a schematic elevational diagram of a prior technology pump jack system having hardwired sucker rod load and position sensors, and connected to a well sucker rod string;

[0022] FIG. 2 illustrates a schematic elevational diagram of a pump jack system having wireless sucker rod load and position sensors coupled to a well sucker rod string, a distance measuring device for determining well bore pipe elongation, and a wireless data input motor speed controller, according to a specific example embodiment of this disclosure;

[0023] FIG. 3 illustrates a more detailed schematic block diagram of the wireless sensor packages shown in FIG. 2;

[0024] FIG. 4 illustrates a schematic elevational diagram of a pump jack system having wireless sucker rod load and distance measurement sensors coupled to a well sucker rod string, a distance measuring device for determining well bore pipe elongation, and a wireless data input motor speed controller, according to another specific example embodiment of this disclosure;

[0025] FIG. 5 illustrates a more detailed schematic block diagram of the wireless sensor packages shown in FIG. 4;

[0026] FIG. 6 illustrates a schematic elevational diagram of a pump jack system having wireless sucker rod load measurement sensors coupled to a well sucker rod string, distance measuring devices for determining well sucker rod string positions and well bore pipe elongation, and a wireless data input motor speed controller, according to still another specific example embodiment of this disclosure;

[0027] FIG. 7 illustrates a more detailed schematic block diagram of the wireless sensor packages shown in FIG. 6; and

[0028] FIG. 8 illustrates schematic diagrams of various power sources available for powering the wireless sensor packages shown in FIGS. 3, 5 and 7, according to specific example embodiments of this disclosure.

[0029] While the present disclosure is susceptible to various modifications and alternative forms, specific example

embodiments thereof have been shown in the drawings and are herein described in detail. It should be understood, however, that the description herein of specific example embodiments is not intended to limit the disclosure to the particular forms disclosed herein, but on the contrary, this disclosure is to cover all modifications and equivalents as defined by the appended claims.

DETAILED DESCRIPTION

[0030] Referring now to the drawing, the details of specific example embodiments are schematically illustrated. Like elements in the drawings will be represented by like numbers, and similar elements will be represented by like numbers with a different lower case letter suffix.

[0031] Referring to FIG. 2, depicted is a schematic elevational diagram of a pump jack system having wireless sucker rod load and position sensors coupled to a well sucker rod string, a distance measuring device for determining well bore pipe elongation, and a wireless motor speed controller, according to a specific example embodiment of this disclosure. The pump jack system, according to the teachings of this disclosure and generally represented by the numeral **200**, comprises a sucker rod string **110**, a polish rod **120**, a horsehead **122**, a rocker beam **124**, connecting rod **132**, counter weight **134**, Pittman arm **136**, motor/gear drive **138**, frame **128** and base **146**. A wireless sensor package **250** is mechanically and electrically attached to the load cell **114**, and moves therewith. In addition, another wireless sensor package **254** attached at about the top of the well bore pipe **118**, e.g., coupled to the flange/fluid takeoff assembly **116**. The wireless sensor package **254** comprises a distance measurement device that accurately measures a distance, *d*, from the wireless sensor package **254** to a reference point **256**, e.g., a target at ground level.

[0032] As the motor/gear drive **138** rotates, the Pittman arm **136** causes the connecting rod **132** to push up or pull down one end of the rocker beam **124**. On the other end of the rocker beam **124** is the horsehead **122** connected to the polish rod **120**. As the horsehead **122** moves up and down so does the polish rod **120** which in turn moves the sucker rod string **110** in and out of the well bore pipe **118**. The well bore pipe **118** is terminated at the flange/fluid takeoff assembly **116** that is adapted to allow fluid (or gas) being pumped out of the well bore pipe **118** to flow to a storage tank/pipeline (not shown). The flange/fluid takeoff assembly **116** also is used to seal around a portion of the sucker rod string **110** so that well fluid does not spill onto the ground. Pressure and flow rate sensors may also be incorporated into the wireless sensor package **254**. It is contemplated and within the scope of this disclosure that the sensor package **254** may alternatively be hard wired to the motor speed controller **258** since the sensor package **254** is stationary with respect to the well bore pipe **118**.

[0033] Axial forces on the sucker rod string **110** may be measured by a load cell **114** that determines the axial forces applied to the sucker rod string **110** when being draw upwards and when being pushed downward. The load cell **114** accomplishes these measurements by being held in a fixed position on the sucker rod string **110** between a top clamp collar **112a** and a bottom clamp collar **112b**. The load cell **114** may be, for example but is not limited to, a Lufkin Industries model 1923.

[0034] The wireless sensor package **250** is mechanically and electrically coupled to the load cell **114**, and moves therewith. A right angle coupling **252** may be used for mounting thereof. The wireless sensor package **250** comprises an

electrical interface for receiving electrical signals from the load cell **114**, and a position sensor, e.g., a tri-axial accelerometer (see FIG. 3). The wireless sensor package **250** is adapted to transmit the sucker rod load and position information over a radio frequency channel(s), e.g., short-range radio, for example but not limited to, frequencies at about 315 MHz, 433 MHz, 868 MHz, 902 to 928 MHz, 2.4 to 2.5 GHz, 5.7 to 5.8 GHz, etc. In addition, any form of transmission and modulation techniques may be used, for example but not limited to, spread spectrum to a compatible receive, e.g., spread spectrum receiver, coupled to a motor speed controller **258**. Computations for optimal motor speeds from the wireless load and position data may be performed in the wireless sensor package **250** and/or the wireless motor speed controller **258**. A central controller receiving load and position information and/or motor speeds from each of the plurality of pump jacks may further be used to control pump speeds of the plurality of pump jacks so as to optimize oil field production, e.g., flow rates of pumped product. The central controller (not shown) may also determine optimal pumping parameters of each of the plurality of pump jacks so as to maximize oil field production.

[0035] Once the sucker rod string **110** axial forces and associated vertical positions thereof are available, a determination(s) can be made for a desired rotational speed(s) of the motor/gear drive **138** to optimize well fluid pumping action. Note that the rotational speed can be varied during a pumping cycle (360 degree rotation of the Pittman arm **136**) to further optimize the well fluid pumping action.

[0036] Referring to FIG. 3, depicted is a more detailed schematic block diagram of the wireless sensor packages shown in FIG. 2. The wireless sensor package **250** may comprise a position sensor **360**, a position sensor interface **362**, top and bottom load cell interfaces **364**, data processing logic and memory storage **368**, a wireless transmitter **370a**, and a power source **366**. The position sensor **360** may be a tri-axial accelerometer, for example but not limited to, Analog Devices ADXL330.

[0037] As the sucker rod string **110** moves up and down, represented schematically by the heavy line double arrow, the position sensor **360** determines at the movement distances from a reference point. Thus real time position signals representative of the positions of the sucker rod string **110** are available from the position sensor **360**. The power source **366** supplies power to the position sensor **360**, the data processing logic and memory storage **368**, and the wireless transmitter **370**. The interfaces **362** and **364** may receive power from the data processing logic and memory storage **368**, and the load cells **114** may receive power from their respective interfaces **364**.

[0038] The top and bottom load cells **114a** and **114b** also make available real time signals representative of the up and down forces, respectively, being applied to the sucker rod string **110**. These real time position and force signals are transferred by the respective position sensor interface **362** and load cell interfaces **364** to the data processing logic and memory storage **368**. The data processing logic and memory storage **368** may comprise a digital processor (not shown) and a memory (not shown). The data processing logic and memory storage **368** may be used for processing the real time position and force signals into optimal motor speed control values to be transmitted to the wireless motor speed controller **258** through the wireless transmitter **370**. Also values of the real time position and force signals may be stored in the

memory of the data processing logic and memory storage **368** for historical and exception reporting, e.g., real time position and/or force values that are outside of the expected norm, and may be exception reported through the wireless transmitter **370** to a control and monitoring system (not shown) or as a shutdown and/or alarm signal to the wireless motor speed controller **258**.

[0039] The sensor package **254** may comprise a distance detector **372**, e.g., a distance determining device using, for example but not limited to, ultrasonic, radio frequency (radar), infrared or laser light timed pulse transmissions. Another wireless transmitter **370b** may be used to transmit the distance information from the distance detector **372** and used for determining the elongation of the well bore pipe **118** due to an increase of the downhole temperature. In addition, pressure and/or flow rate sensors may be coupled at the flange/fluid takeoff assembly **116**. The sensor package **254** may be powered through an internal power source (e.g., wireless sensor package) or from the motor speed controller **258** (hardwired).

[0040] Referring to FIG. 4, depicted is a schematic elevational diagram of a pump jack system having wireless sucker rod load and distance measurement sensors coupled to a well sucker rod string, a distance measuring device for determining well bore pipe elongation, and a wireless motor, speed controller, according to another specific example embodiment of this disclosure. The pump jack system, according to the teachings of this disclosure and generally represented by the numeral **400**, comprises a sucker rod string **110**, a polish rod **120**, a horsehead **122**, a rocker beam **124**, connecting rod **132**, counter weight **134**, Pittman arm **136**, motor/gear drive **138**, frame **128** and base **146**. A wireless sensor package **450** is mechanically and electrically coupled to the load cell **114**, and moves therewith. In addition, another wireless sensor package **254** may be attached at about the top of the well bore pipe **118**, e.g., coupled to the flange/fluid takeoff assembly **116**. The sensor package **254** comprises a distance measurement device that accurately measures a distance, d_1 , from the sensor package **254** to a reference point **256a**, e.g., a target at ground level. The sensor package **254** may be wireless or hard wired to the motor speed controller **258**.

[0041] Axial forces on the sucker rod string **110** may be measured by the load cell **114** as more fully described hereinabove. The wireless sensor package **450** comprises an electrical interface for receiving electrical signals from the load cell **114**, and a distance measurement sensor, e.g., ultrasonic, radio frequency, infrared, laser light that measure a distance, d_2 , representing the vertical distance of the load cell **114** from the reference point **256b**, e.g., a target at ground level. The wireless sensor package **450** is adapted to transmit the sucker rod load and distance information over a radio frequency channel(s) as described more fully hereinabove.

[0042] It is contemplated and within the scope of this disclosure that the distance measurement device that measures the distance (position) of the load cell **114** may be located at the reference point **256b** at or about ground level. By locating this distance measurement device at a fixed location (reference point **256b**) it can now be either wireless or wired to the motor controller **258**. In addition, the movable wireless sensor package **450** may be simplified as it need only transmit load cell **114** information wirelessly, as more fully described herein. Also any intelligent electronics may now be located with the stationary (fixed) distance measurement device, and

a very low power and simple (e.g., Bluetooth) wireless communications protocol may be utilized for the real time load cell data.

[0043] Referring to FIG. 5, depicted is a more detailed schematic block diagram of the wireless sensor packages shown in FIG. 4. The wireless sensor package 450 may comprise a distance detector 560, a distance detector interface 562, top and bottom load cell interfaces 364, data processing logic and memory storage 368, a wireless transmitter 370a, and a power source 366. The distance detector 560 may be similar to the distance detector 372 as more fully described hereinabove.

[0044] As the sucker rod string 110 moves up and down, represented schematically by the heavy line double arrow, the distance detector 560 determines the distances, d_2 , from the reference point 256b. Thus real time positions derived from the measured distances, d_2 , are representative of the positions of the sucker rod string 110. The power source 366 supplies power to the distance detector 560, the data processing logic and memory storage 368, and the wireless transmitter 370a. The interfaces 362 and 364 may receive power from the data processing logic and memory storage 368, and the load cells 114 may receive power from their respective interfaces 364.

[0045] The top and bottom load cells 114a and 114b also make available real time signals representative of the up and down forces, respectively, being applied to the sucker rod string 110. These real time position and force signals are transferred by the respective distance detector interface 562 and load cell interfaces 364 to the data processing logic and memory storage 368. The data processing logic and memory storage 368 may comprise a digital processor (not shown) and a memory (not shown). The data processing logic and memory storage 368 may be used for processing the real time position and force signals into optimal motor speed control values to be transmitted to the wireless motor speed controller 258 through the wireless transmitter 370a. Also values of the real time position and force signals may be stored in the memory of the data processing logic and memory storage 368 for historical and exception reporting, e.g., real time position and/or force values that are outside of the expected norm, and may be exception reported through the wireless transmitter 370a to a control and monitoring system (not shown) or as a shutdown and/or alarm signal to the wireless motor speed controller 258.

[0046] It is contemplated and within the scope of this disclosure that the distance detector 560, the distance detector interface 562 and the data processing and storage 368 may be located at the fixed location (reference point 256b) and the wireless sensor package 450 need only comprise the load cell interfaces 364, a power source 366a and a wireless transmitter 370a. The housing of the wireless sensor package 450 could serve as a reflective target for the distance detector 560 or a distance measuring signal reflective plate can be attached thereto. See also FIG. 7 and the disclosure therefor hereinbelow.

[0047] The sensor package 254 may comprise a distance detector 372, e.g., a distance determining device using, for example but is not limited to, ultrasonic, radio frequency (radar), infrared or laser light timed pulse transmissions. Another wireless transmitter 370b may be used to transmit the distance information from the distance detector 372 and used for determining the elongation of the well bore pipe 118 due to an increase of the downhole temperature. In addition,

pressure and/or flow rate sensors may be coupled at the flange/fluid takeoff assembly 116.

[0048] Referring to FIG. 6, depicted is a schematic elevational diagram of a pump jack system having wireless sucker rod load measurement sensors coupled to a well sucker rod string, distance measuring devices for determining well sucker rod string positions and well bore pipe elongation, and a wireless motor speed controller, according to still another specific example embodiment of this disclosure. The pump jack system, according to the teachings of this disclosure and generally represented by the numeral 600, comprises a sucker rod string 110, a polish rod 120, a horsehead 122, a rocker beam 124, connecting rod 132, counter weight 134, Pittman arm 136, motor/gear drive 138, frame 128 and base 146. A wireless sensor package 650 is mechanically and electrically attached to the load cell 114, and moves therewith. In addition, another wireless sensor package 654 attached at about the top of the well bore pipe 118, e.g., coupled to the flange/fluid takeoff assembly 116. The sensor package 654 comprises distance measurement devices that accurately measure distance, d_b , from the sensor package 654 to a reference point 256, e.g., a target at ground level, and distance, d_a , from the sensor package 654 to the sensor package 650 (also used as a target). The sensor package 654 may be wireless or hard wired to the motor speed controller 258 since it remains stationary. The sum of the measured distances, d_a and d_b , plus the height of the sensor package 654 will be representative of an accurate measured distance of the load cell 114 from the reference point 256. Both distances, d_a and d_b , have to be taken into account since elongation of the well bore pipe 118 vary depending upon the temperatures along the pipe 118. An alternative mounting of a distance measurement sensor (not shown) at the fixed reference point 256 may be used and then the distance from the ground mounted (or fixed pedestal mounted) distance detector in the sensor package 654a would measure the housing as a target of the sensor package 650. An advantage of putting the distance measurement detectors in the fixed sensor package 652 is that only the load cell sensors in the sensor package 650 need be wireless, though preferably all sensor packages 650 and 652 may be wireless.

[0049] Axial forces on the sucker rod string 110 may be measured by the load cell 114 as more fully described hereinabove. The wireless sensor package 650 comprises an electrical interface for receiving electrical signals from the load cell 114. The wireless sensor package 650 is adapted to transmit the sucker rod load over a radio frequency channel(s) as described more fully hereinabove.

[0050] Referring to FIG. 7, depicted is a more detailed schematic block diagram of the wireless sensor packages shown in FIG. 6. The wireless sensor package 650 may comprise top and bottom load cell interfaces 364, data processing logic and memory storage 368, a wireless transmitter 370a, and a power source 366. It is contemplated and within the scope of this disclosure that the data processing and storage 368 may be located in the sensor package 652 and that the wireless transmitter 370a may communicate directly with a receiver (not shown) in the sensor package 652. This will further reduce the power consumption used by the sensor package 650. The distance detector 760 may be similar to the distance detector 560 as more fully described hereinabove.

[0051] As the sucker rod string 110 moves up and down, represented schematically by the heavy line double arrow, the distance detector 760 determines the distance, d_a , from the top of the sensor package 654 housing, and the distance

detector **762** determines the distance, d_b , from the top of the well bore pipe **118** to the reference point **256** (e.g., ground reference). Thus real time positions derived from the measured distances, d_a plus d_b plus the height of the sensor package **654** housing, represent the positions of the sucker rod string **110**. Power sources supply power to the distance detectors **760** and **762**, the data processing logic and memory storage **368**, and the wireless transmitters **370**. The interfaces **362** and **364** may receive power from the data processing logic and memory storage **368**, and the load cells **114** may receive power from their respective interfaces **364**. The data processing logic may also be located in the sensor package **654** and that the sensor package **654** may be either wireless or hard wired to the motor controller **258**. Also the wireless transmitter **370a** may send the load cell information first to a receiver (not shown) in the stationary sensor package **654** where all of the smart processing may also be located.

[0052] The top and bottom load cells **114a** and **114b** also make available real time signals representative of the up and down forces, respectively, being applied to the sucker rod string **110**. These real time position and force signals are transferred by the respective distance detector interface **562** and load cell interfaces **364** to the data processing logic and memory storage **368**. The data processing logic and memory storage **368** may comprise a digital processor (not shown) and a memory (not shown). The data processing logic and memory storage **368** may be used for processing the real time position and force signals into optimal motor speed control values to be transmitted to the wireless motor speed controller **258** through the wireless transmitter **370a**. Also values of the real time position and force signals may be stored in the memory of the data processing logic and memory storage **368** for historical and exception reporting, e.g., real time position and/or force values that are outside of the expected norm, and may be exception reported through the wireless transmitter **370a** to a control and monitoring system (not shown) or as a shutdown and/or alarm signal to the wireless motor speed controller **258**.

[0053] Referring to FIG. 8, depicted are schematic diagrams of various power sources available for powering the wireless sensor packages shown in FIGS. 3, 5 and 7, according to specific example embodiments of this disclosure. A rechargeable battery **366a** may be used as the power source **366**. A capacitor **366b** may be charged as described hereinafter and used as the power source **366**. A battery and solar cell charger **366c** may be used as the power source **366**. An inductive pick-up charger coil **480** external to the wireless sensor package **250**, **450** or **650** may be used to inductively charge the internal charging coil **482** coupled to the battery **478** through rectifier **484**. A motion charger and battery **366c** may comprise a charging pick-up coil in close proximity to a permanent magnet **488**, wherein the permanent magnet moves in an axial direction depending upon the axial motion of the wireless sensor package **250**. The magnet **488** has mass and travels back and forth between the springs **490** when the wireless sensor package **250**, **450** or **650** is moving up and down, thus charging the battery **478** through the diode **484**. The battery **478** may be replaced with the capacitor **492** and be similarly charged. It is contemplated and within the scope of this disclosure that other sources of power **366** not disclosed herein may be also be utilized to power the components of the wireless sensor package **250**.

[0054] While embodiments of this disclosure have been depicted, described, and are defined by reference to example

embodiments of the disclosure, such references do not imply a limitation on the disclosure, and no such limitation is to be inferred. The subject matter disclosed is capable of considerable modification, alteration, and equivalents in form and function, as will occur to those ordinarily skilled in the pertinent art and having the benefit of this disclosure. The depicted and described embodiments of this disclosure are examples only, and are not exhaustive of the scope of the disclosure.

What is claimed is

1. A pump jack adapted for monitoring sucker rod load and position, comprising:

- a sucker rod string in a well bore pipe;
- a polished rod coupled to the sucker rod string;
- a horsehead coupled to the polished rod;
- a rocker beam coupled to the horsehead;
- a connecting rod coupled to the rocker beam;
- a counter weight coupled to the connecting rod;
- a pittman arm coupled to the connecting rod and counter weight;
- a variable speed motor-gear drive assembly coupled to the pittman arm for rotational movement thereof;
- a frame pivotally coupled to the rocker beam;
- a base attached to the frame;
- first and second force sensors attached to a proximate end of the sucker rod string, wherein the first and second force sensors measure elongation and compression stresses, respectively, of the sucker rod string while the sucker rod string moves up and down in the well bore pipe;
- a position sensor attached toward the proximate end of the sucker rod string, wherein the position sensor determines positions of the sucker rod string;
- a sensor interface assembly having wireless transmitting capabilities, wherein the sensor interface assembly is attached to the sucker rod string, and is coupled to the first and second force measurement sensors and the position sensor, whereby the sucker rod string forces and position information are wirelessly transmitted therefrom; and
- a wireless receiver coupled to the variable speed motor-gear drive assembly, wherein the wireless receiver receives the force and position information transmitted from the interface assembly for determining control of rotational speed of the variable speed motor-gear drive assembly.

2. The pump jack according to claim 1, wherein the position sensor is a tri-axial accelerometer.

3. The pump jack according to claim 1, wherein the position sensor is a distance measuring device for measuring distances between the proximate end of the sucker rod string and a reference point.

4. The pump jack according to claim 3, wherein the distance measuring device uses ultrasonic pulses for measuring the distances.

5. The pump jack according to claim 3, wherein the distance measuring device uses radio frequency pulses for measuring the distances.

6. The pump jack according to claim 3, wherein the distance measuring device uses infrared pulses for measuring the distances.

7. The pump jack according to claim 3, wherein the distance measuring device uses laser light pulses for measuring the distances.

8. The pump jack according to claim **1**, further comprising a well bore pipe elongation distance sensor coupled to a proximate end of the well bore pipe, and from which elongation length of the well bore pipe is available as elongation data.

9. The pump jack according to claim **1**, further comprising pressure and flow rate sensors coupled to a flange/fluid takeoff assembly that is coupled to the proximate end of the well bore pipe, and from which pressure and flow rate at the flange/fluid takeoff assembly are available as pressure and flow rate data, respectively.

10. An apparatus for monitoring position and load of a sucker rod in a pump jack, comprising:

first and second force sensors attached at a proximate end of a sucker rod string of a pump jack, wherein the first and second force sensors measure elongation and compression stresses, respectively, of the sucker rod string while the sucker rod string moves up and down in a well bore pipe;

a position sensor attached toward the proximate end of the sucker rod string, wherein the position sensor determines positions of the sucker rod string; and

a sensor interface assembly having wireless transmitting capabilities, wherein the sensor interface assembly is attached to the sucker rod string, and is coupled to the first and second force measurement sensors and the position sensor, whereby the sucker rod string forces and position information are wirelessly transmitted therefrom.

11. The apparatus according to claim **10**, wherein the position sensor is a distance measuring device for measuring distances between the proximate end of the sucker rod string and a reference point.

12. The apparatus according to claim **11**, wherein the distance measuring device uses ultrasonic pulses for measuring the distances.

13. The apparatus according to claim **11**, wherein the distance measuring device uses radio frequency pulses for measuring the distances.

14. The apparatus according to claim **11**, wherein the distance measuring device uses infrared pulses for measuring the distances.

15. The apparatus according to claim **11**, wherein the distance measuring device uses laser light pulses for measuring the distances.

16. A pump jack adapted for monitoring sucker rod load and position, comprising:

a sucker rod string in a well bore pipe;

a polished rod coupled to the sucker rod string;

a horsehead coupled to the polished rod;

a rocker beam coupled to the horsehead;

a connecting rod coupled to the rocker beam;

a counter weight coupled to the connecting rod;

a pittman arm coupled to the connecting rod and counter weight;

a variable speed motor-gear drive assembly coupled to the pittman arm for rotational movement thereof;

a frame pivotally coupled to the rocker beam;

a base attached to the frame;

first and second force sensors attached to a proximate end of the sucker rod string, wherein the first and second force sensors measure elongation and compression

stresses, respectively, of the sucker rod string while the sucker rod string moves up and down in the well bore pipe;

a sensor interface assembly having wireless transmitting capabilities, wherein the sensor interface assembly is attached to the sucker rod string, and is coupled to the first and second force measurement sensors, whereby the sucker rod string force information is wirelessly transmitted therefrom;

a distance measuring device attached on a plan of the base and under the sensor interface assembly, wherein the position sensor determines positions of the sucker rod string by measuring distances between the distance measuring device and the sensor interface assembly; and

a wireless receiver coupled to the variable speed motor-gear drive assembly, wherein the wireless receiver receives the force information transmitted from the sensor interface assembly, and wherein position information from the distance measuring device is coupled to the variable speed motor-gear drive assembly, whereby control of rotational speed of the variable speed motor-gear drive assembly is determined from the force and position information.

17. The pump jack according to claim **16**, wherein the distance measuring device uses ultrasonic pulses for measuring the distances.

18. The pump jack according to claim **16**, wherein the distance measuring device uses radio frequency pulses for measuring the distances.

19. The pump jack according to claim **16**, wherein the distance measuring device uses infrared pulses for measuring the distances.

20. The pump jack according to claim **16**, wherein the distance measuring device uses laser light pulses for measuring the distances.

21. The pump jack according to claim **16**, further comprising a well bore pipe elongation distance sensor coupled to a proximate end of the well bore pipe, and from which elongation length of the well bore pipe is available as elongation data.

22. The pump jack according to claim **16**, further comprising pressure and flow rate sensors coupled to a flange/fluid takeoff assembly that is coupled to the proximate end of the well bore pipe, and from which pressure and flow rate at the flange/fluid takeoff assembly are available as pressure and flow rate data, respectively.

23. An apparatus for monitoring position and load of a sucker rod in a pump jack, comprising:

first and second force sensors attached at a proximate end of a sucker rod string of a pump jack, wherein the first and second force sensors measure elongation and compression stresses, respectively, of the sucker rod string while the sucker rod string moves up and down in a well bore pipe;

a sensor interface assembly having wireless transmitting capabilities, wherein the sensor interface assembly is attached to the sucker rod string, and is coupled to the first and second force measurement sensors, whereby the sucker rod string force information is wirelessly transmitted therefrom;

a distance measuring device attached on a plane of a base of the pump jack and under the sensor interface assembly,

wherein the distance measuring device determines positions of the sucker rod string by measuring distances between the distance measuring device and the sensor interface assembly; and

a wireless receiver coupled to the variable speed motor-gear drive assembly, wherein the wireless receiver receives the force information transmitted from the sensor interface assembly, and wherein position information from the distance measuring device is coupled to the variable speed motor-gear drive assembly, whereby control of rotational speed of the variable speed motor-gear drive assembly is determined from the force and position information.

24. The apparatus according to claim **23**, wherein the distance measuring device uses ultrasonic pulses for measuring the distances.

25. The apparatus according to claim **23**, wherein the distance measuring device uses radio frequency pulses for measuring the distances.

26. The apparatus according to claim **23**, wherein the distance measuring device uses infrared pulses for measuring the distances.

27. The apparatus according to claim **23**, wherein the distance measuring device uses laser light pulses for measuring the distances.

* * * * *