



US00D486727S

(12) **United States Design Patent**
Smith et al.

(10) **Patent No.:** **US D486,727 S**

(45) **Date of Patent:** **** Feb. 17, 2004**

(54) **CASTER WHEEL LOCK BRACKET**

6,286,184 B1 9/2001 Dean et al. 16/35 R
6,453,508 B1 9/2002 Denner 16/35 R
6,484,359 B1 11/2002 Guttman et al. 16/18 R

(76) Inventors: **James C. Smith**, 336 Harder Rd.,
Hayward, CA (US) 94544; **David J.
Taylor**, 129 Sugar Creek La., Alamo,
CA (US) 94507

OTHER PUBLICATIONS

Modern Suspension System, caster shroud highlighted at
bottom of page, Jun. 27, 1988, p. 9.*

(**) **Term:** **14 Years**

* cited by examiner

(21) **Appl. No.:** **29/181,394**

Primary Examiner—Holly Baynham

(22) **Filed:** **May 9, 2003**

(74) *Attorney, Agent, or Firm*—Donald L. Beeson

(51) **LOC (7) Cl.** **08-05**

(57) **CLAIM**

(52) **U.S. Cl.** **D8/375**

The ornamental design for a caster wheel lock bracket, as
shown and described.

(58) **Field of Search** D8/375; 16/18 R,
16/18 CG, 45

DESCRIPTION

(56) **References Cited**

FIG. 1 is a top perspective view of a caster wheel lock
bracket showing our new design;
FIG. 2 is another top perspective view thereof;
FIG. 3 is a top plan view thereof;
FIG. 4 is a bottom plan view thereof;
FIG. 5 is a rear elevational view thereof;
FIG. 6 is a left side elevational view thereof, the right side
being a mirror image; and,
FIG. 7 is a front elevational view thereof.
The broken lines shown in FIGS. 1–7 immediately adjacent
the shaded areas represent the bounds of the claimed design,
and all other broken lines are for illustrative purposes only.
None of the broken lines form a part of our claimed design.

U.S. PATENT DOCUMENTS

2,345,442 A	3/1944	Winter et al.	16/35
2,572,548 A	10/1951	Weisz et al.	16/35
2,695,683 A	11/1954	Forbes	188/77
3,083,398 A *	4/1963	Swalm	16/18 R
4,035,864 A	7/1977	Schroder	16/35 R
4,349,937 A	9/1982	Fontana	16/35 R
4,835,815 A	6/1989	Mellwig et al.	16/35 R
4,870,715 A	10/1989	Schnuell	16/35 R
5,236,066 A	8/1993	O'Neal et al.	188/1.12
5,675,864 A	10/1997	Chou	16/35 R
5,829,096 A	11/1998	Perry	16/35 R
D421,563 S *	3/2000	Hollis	D8/375
6,223,864 B1	5/2001	Phelps et al.	188/19

1 Claim, 3 Drawing Sheets

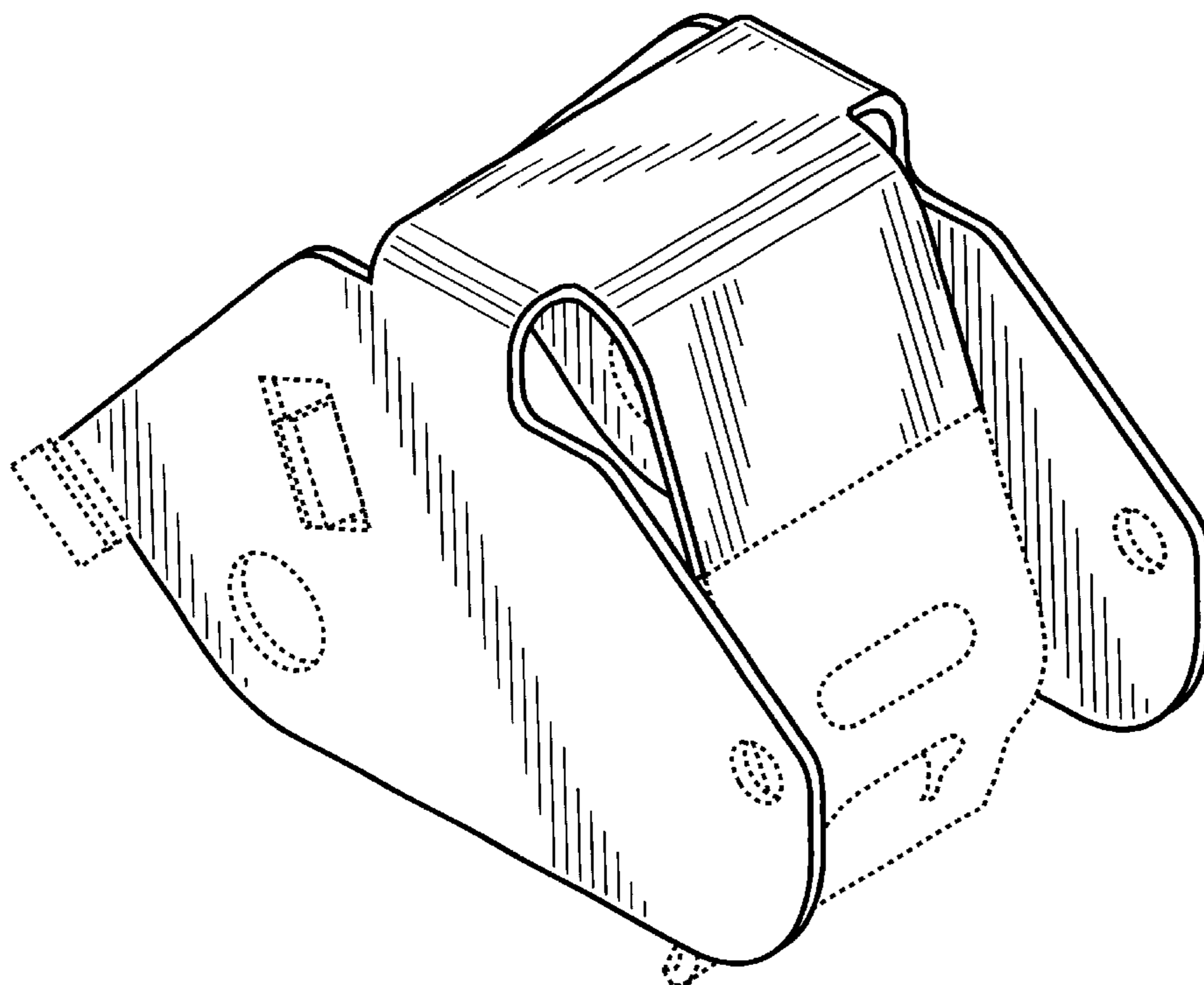

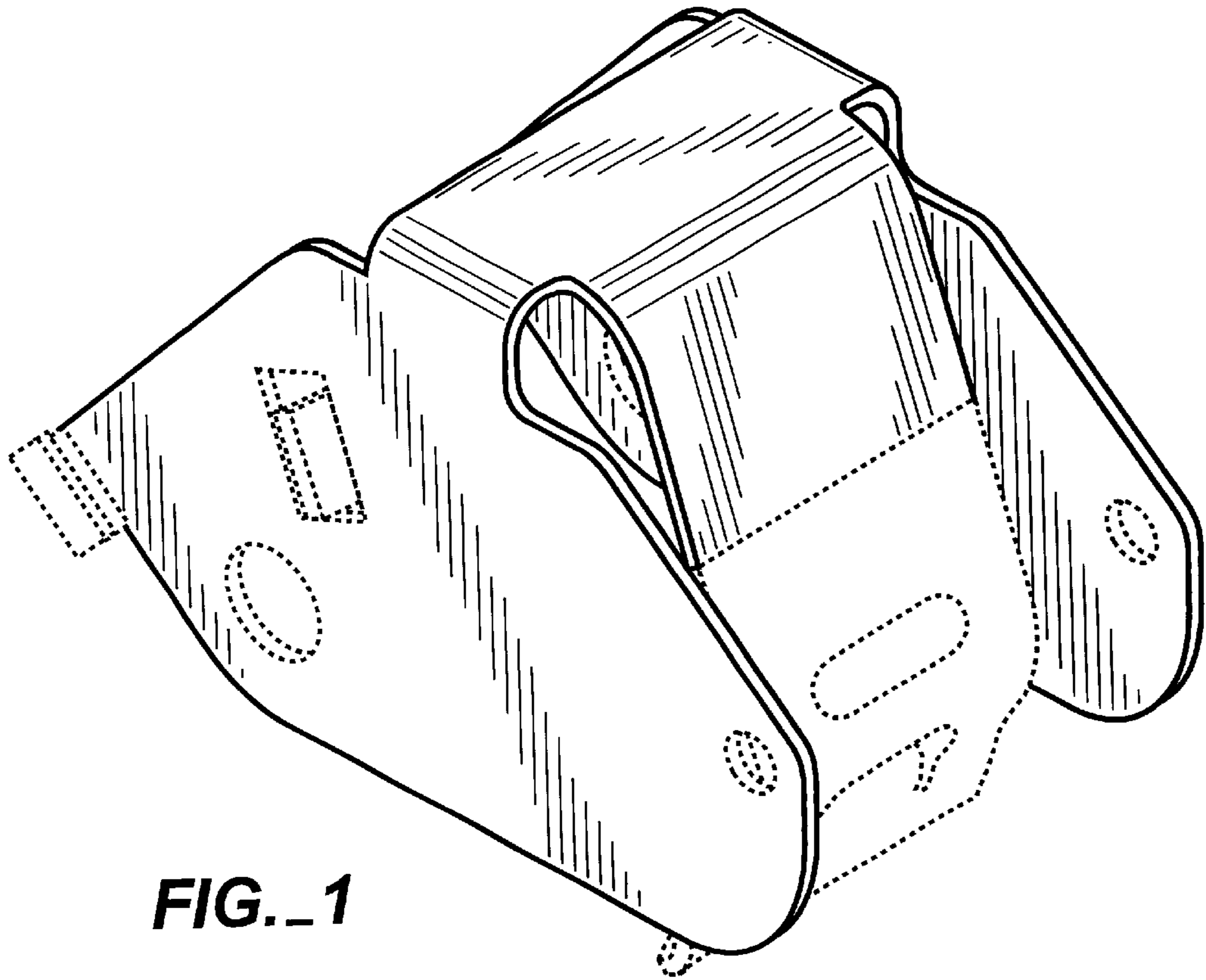

FIG._1

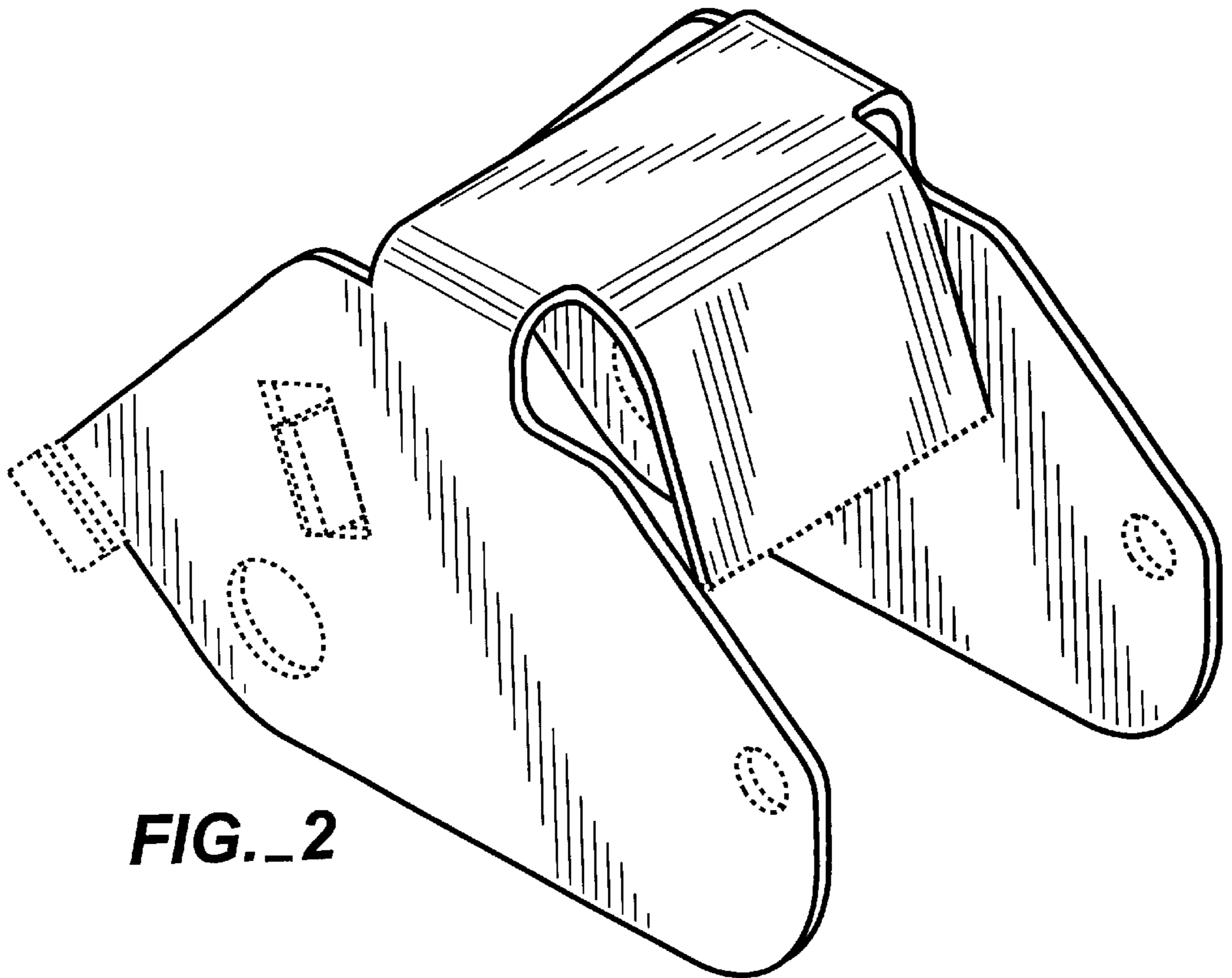

FIG._2

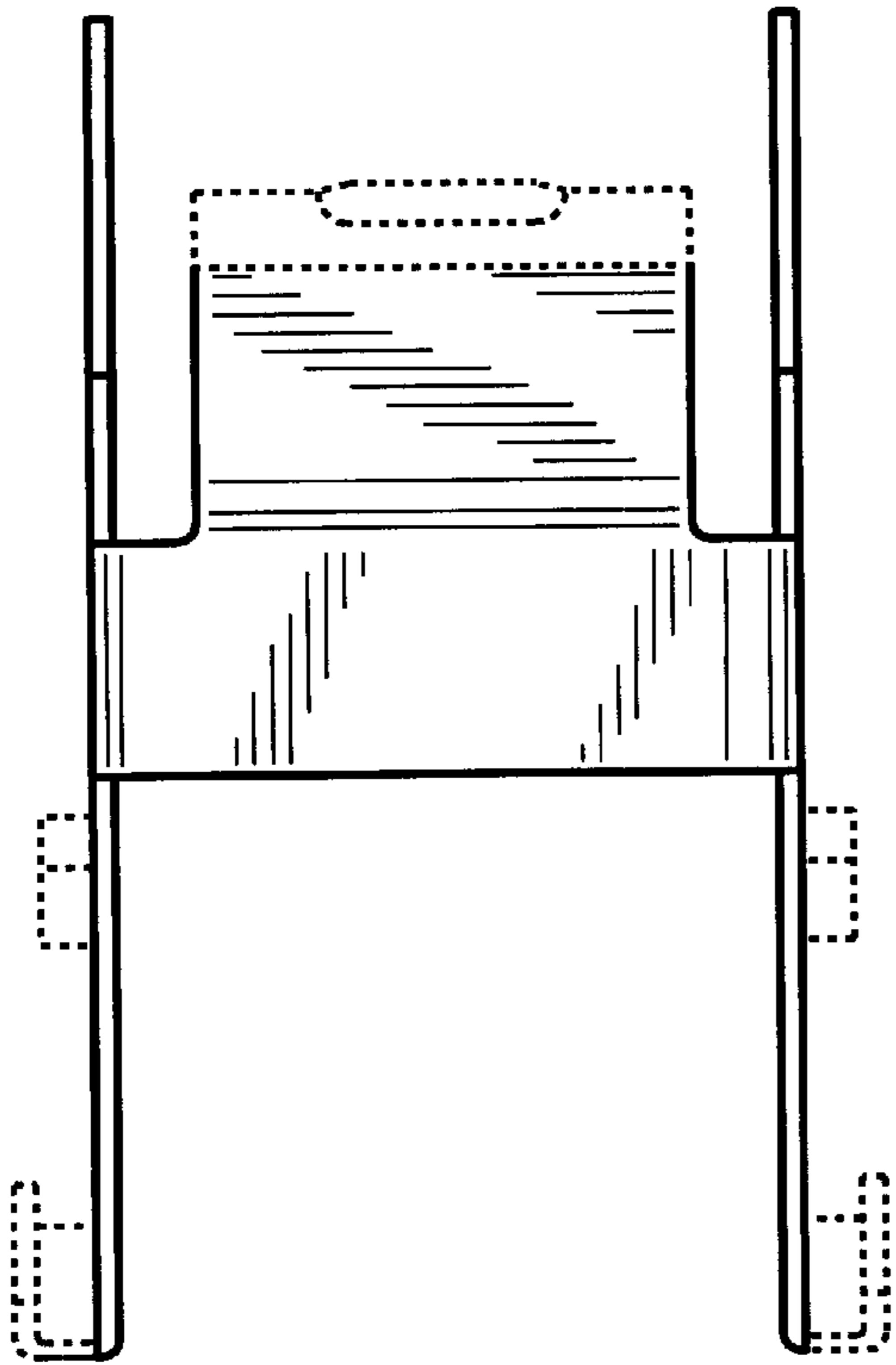

FIG._3

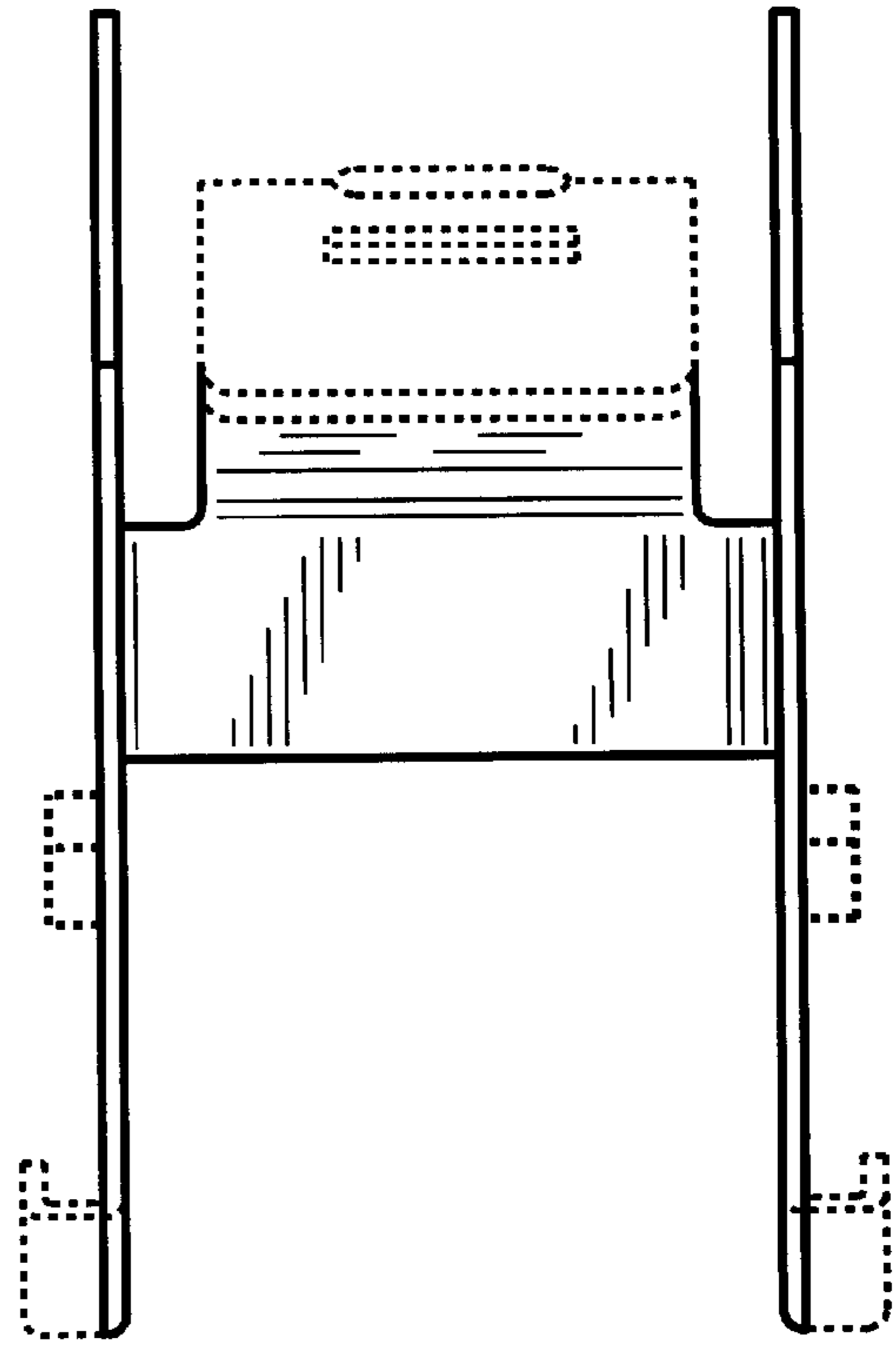

FIG._4

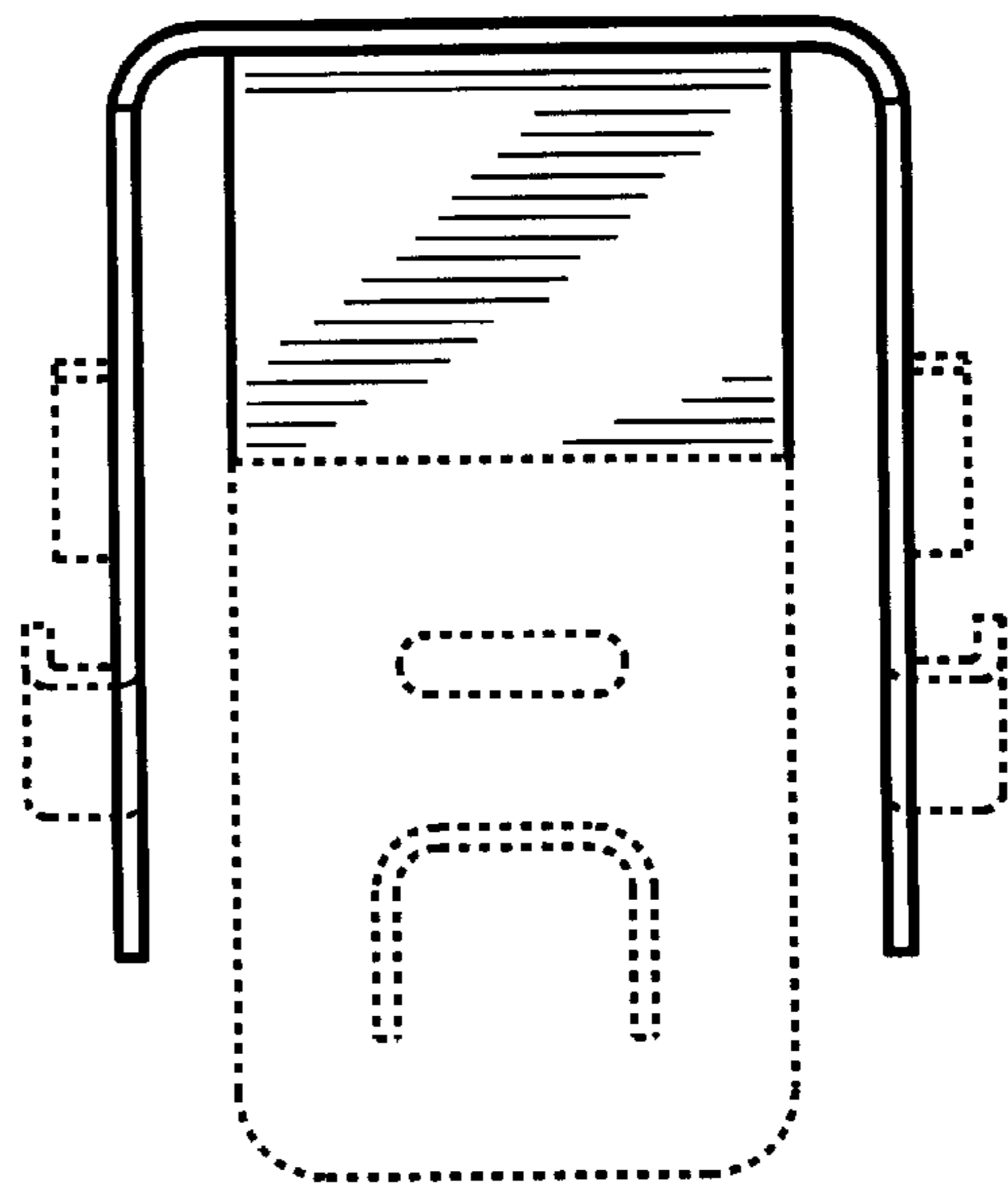

FIG._5

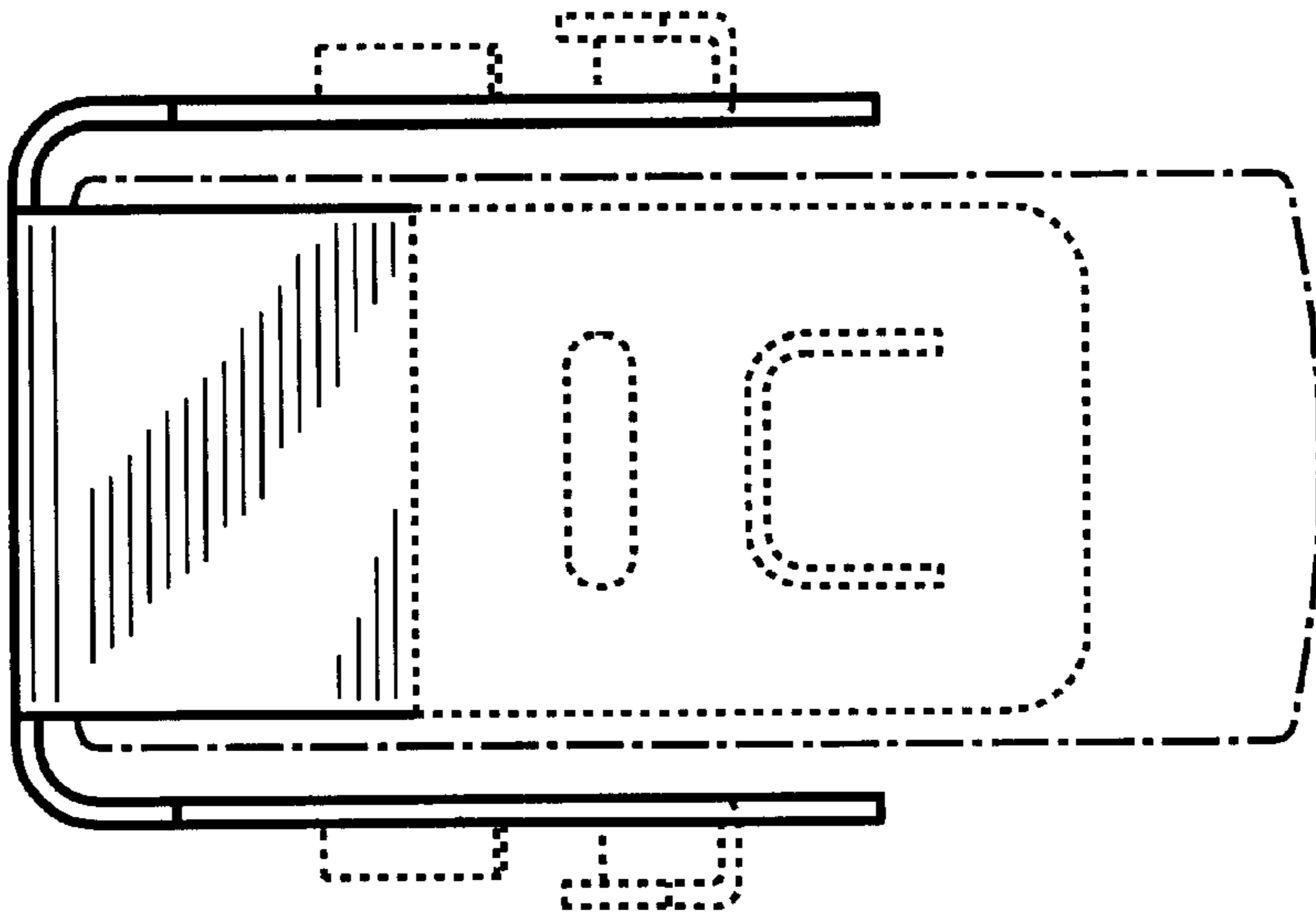

FIG. 7

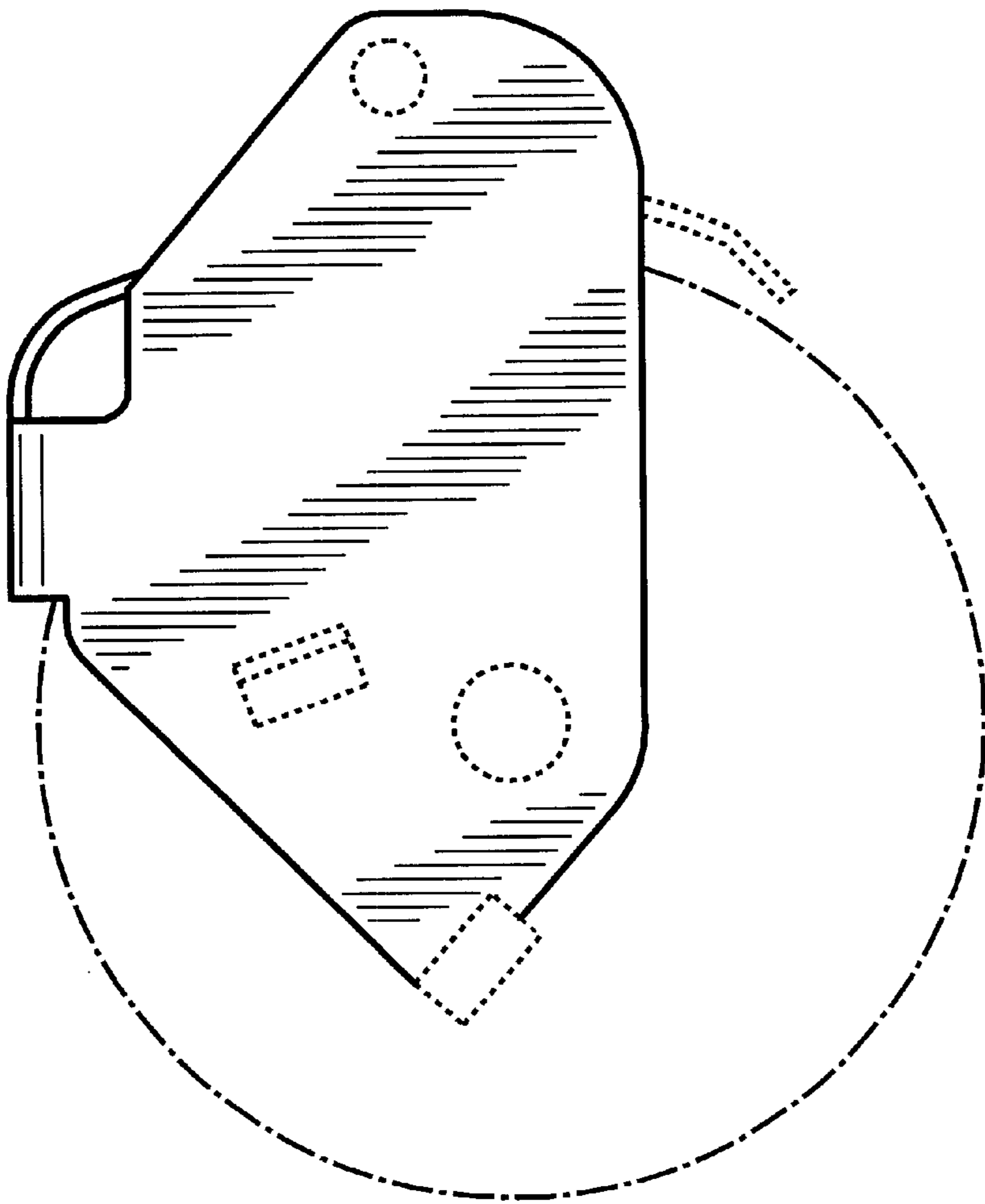

FIG. 6