

(43) Date of A Publication 14.06.2000

(21) Application No **9929053.8**

(22) Date of Filing **08.12.1999**

(30) Priority Data

(31) **9826986** (32) **08.12.1998** (33) **GB**

(71) Applicant(s)

Simoco International Limited
(Incorporated in the United Kingdom)
PO Box 24, St. Andrews Road, CAMBRIDGE, CB4 1DP,
United Kingdom

(72) Inventor(s)

Alister John Bailey

(51) INT CL⁷
H04Q 7/28

(52) UK CL (Edition R)
H4L LDM L1H10

(56) Documents Cited
WO 97/50266 A2 US 5506837 A

(58) Field of Search
UK CL (Edition R) **H4L LDM**
INT CL⁷ **H04Q 7/28**
On-Line - WPI, EPODOC

(74) Agent and/or Address for Service

Frank B Dehn & Co
179 Queen Victoria Street, LONDON, EC4V 4EL,
United Kingdom

(54) Abstract Title

Providing passive group call subscribers with half-duplex connections

(57) A Trunked Private Mobile Radio (PMR) system which includes a fixed radio network which includes base stations PS1, PS2 and PS3 linked by land line or microwave connections, and in radio communication with mobile stations SS1 - SS7. A group call is set up with mobile stations SS2 and SS7 having a full duplex connection (via the fixed radio network) to each other, and all the remaining mobile stations listening in over simplex or half-duplex connections. The radio system operates to rebroadcast the speech signals from mobile stations SS2 and SS7 over the half-duplex radio connections to the remaining mobile stations in the group, so that those mobile stations can listen in to the combined speech of the full duplex call.

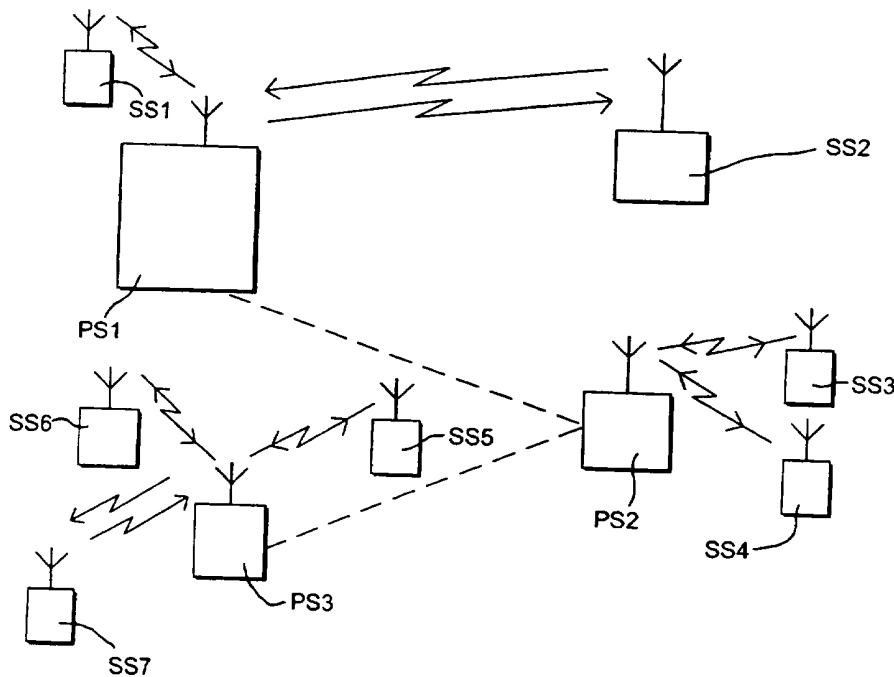

FIG. 1.

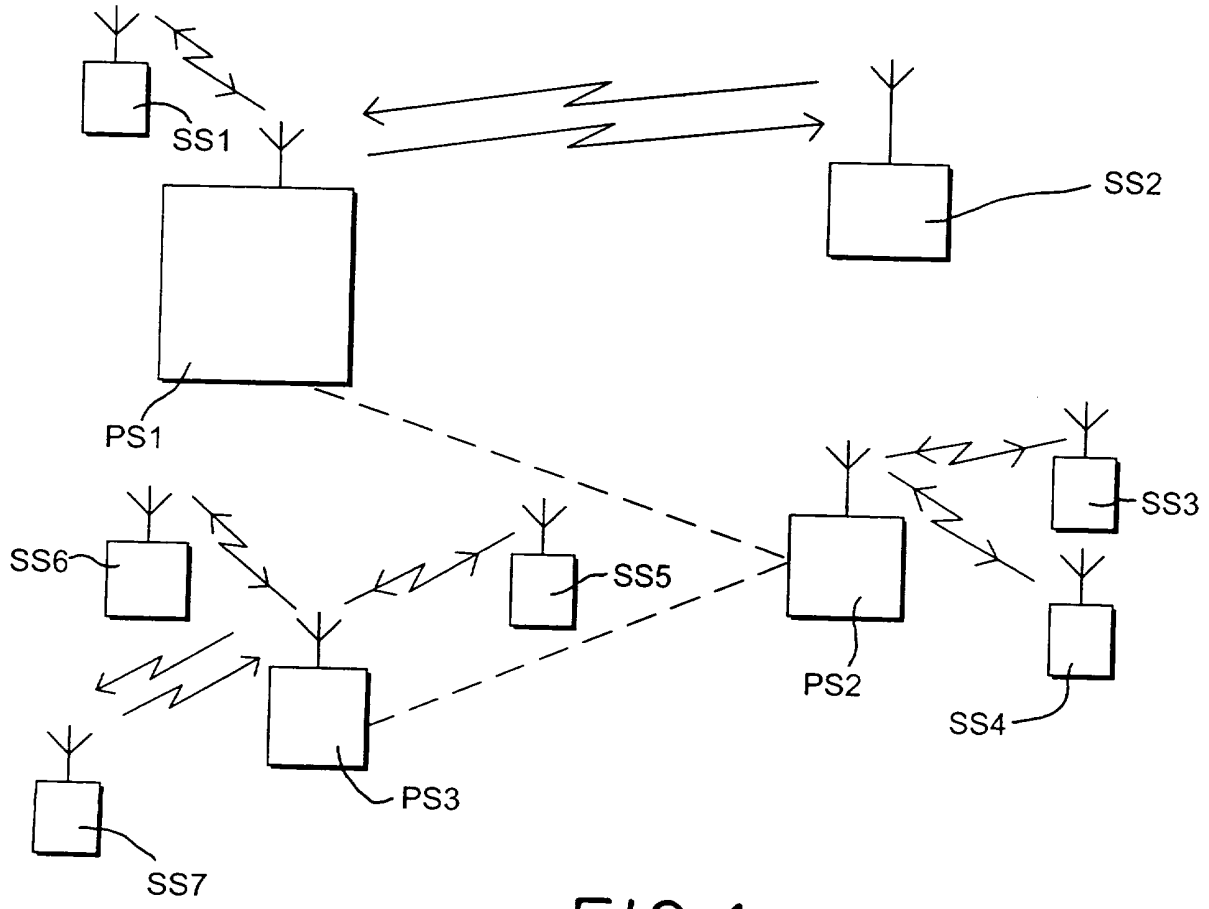

FIG. 1.

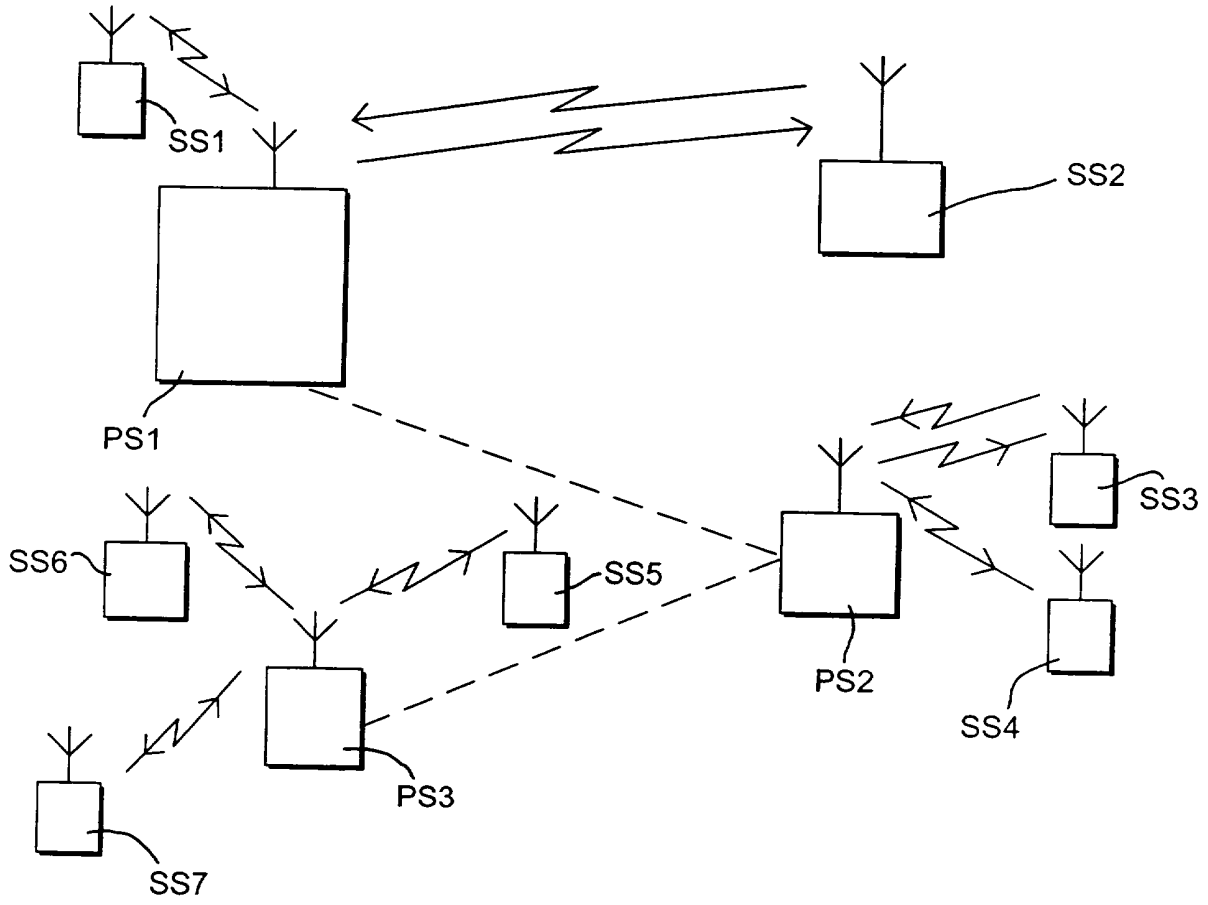

FIG. 2.

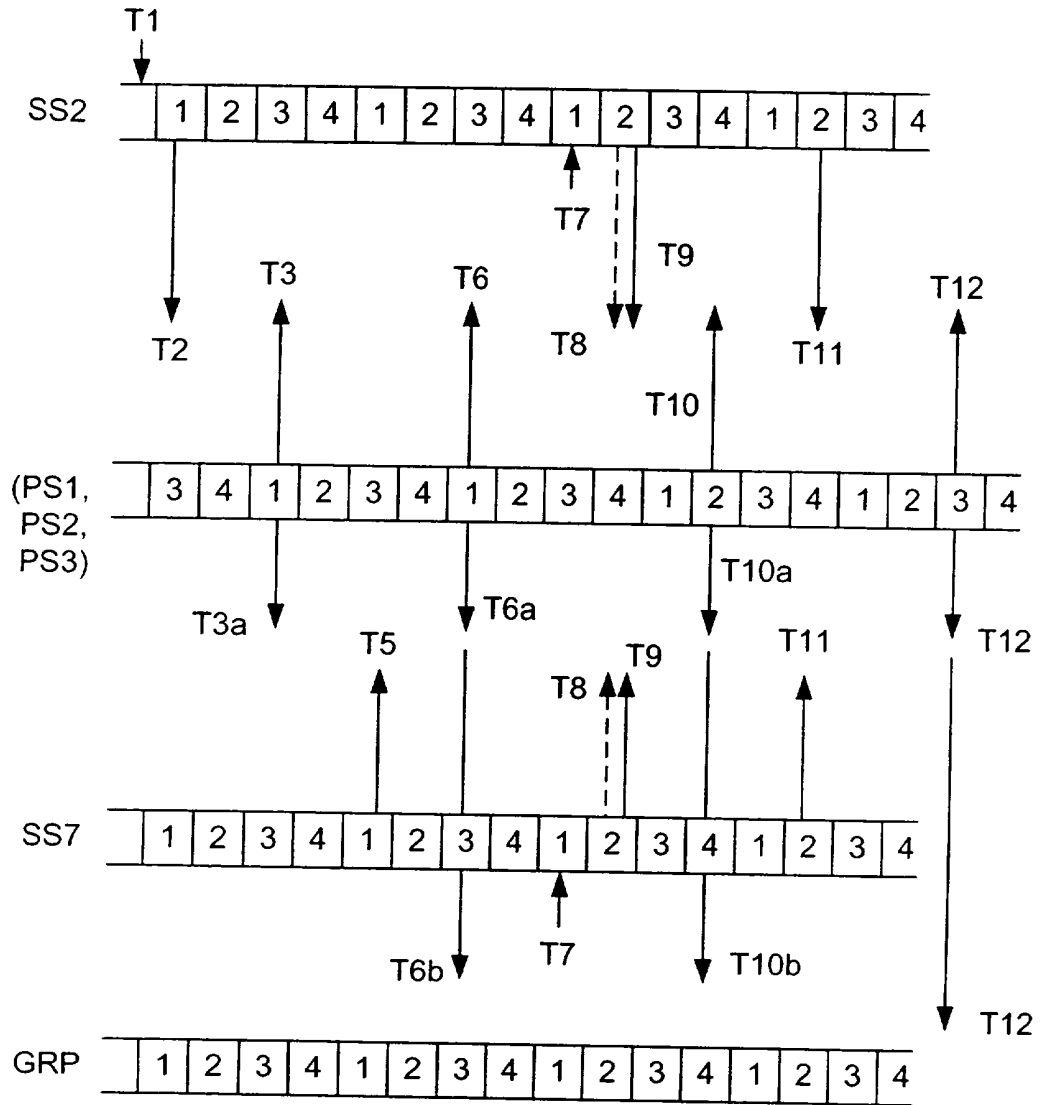

FIG. 3.

Radio Communication System

The present invention relates to a radio
5 communication system such as a private mobile radio
(PMR) system, and in particular to such a system in
which a conversation between two parties can be
broadcast simultaneously to other users of the system.

Many users of private mobile radio systems make
10 extensive use of half-duplex (i.e. in which there is
voice transmission in both directions, but in only one
direction at any one time) group call arrangements to
enable all members of a group of users to listen in to
communications from other members of the group. For
15 example, the UK police operate "all-informed" groups by
using such half-duplex group-call functions.

In such an arrangement each party in the group will
typically have a half-duplex connection to the fixed
radio network (such that they can only transmit to or
20 receive from the fixed network at any given time, and
select which they want to do usually by pressing their
push-to-talk (PTT) button). Only one party in the group
can talk at any given time, and the remaining members of
the call group all listen in on their respective radio
25 channel.

It is also known in private mobile radio systems to
use simplex (i.e. in which there is voice transmission
in one direction only) broadcasts to a group of users to
enable all members of a group of users to listen to (but
30 not reply to) the same broadcast simultaneously.

Newly proposed trunked mobile radio communications
systems such as the Terrestrial Trunked Radio (TETRA)
system have provision for full-duplex calling (i.e. in
which there is voice transmission in both directions
35 simultaneously), as do cellular mobile telephone
systems. In such an arrangement a mobile radio station
can simultaneously both transmit a signal to and receive

a signal from the other party. Each party would therefore typically communicate over two separate radio channels simultaneously (one in each transmission direction). Such full-duplex communication is
5 inherently a one-to-one teleservice between individuals, rather than groups.

However, the Applicants have recognised that many users of new radio communications systems that support full-duplex calling may still wish to maintain "all-informed" groups as they had previously.
10

One way to provide for "all-informed" groups with a full-duplex system would be to provide a "conference call" facility with full-duplex connection between all the members of the group. This would provide an
15 arrangement in which all members of the group could talk to each other simultaneously and be listened into by the remaining group members. However, the Applicants have recognised that such a technique requires a relatively large radio channel capacity, which may be undesirable,
20 for example when the fully informed group is a large one, such as could be the case for the police.

According to a first aspect of the present invention, there is provided a method of establishing a call between a group of call terminating stations of a
25 mobile radio communications system, where at least some of the stations in the group are mobile radio stations, comprising:

setting up a full-duplex connection between at least two stations in the group; and
30 retransmitting the speech transmitted over the full-duplex connection to one or more mobile stations in the group not linked by the full-duplex connection via a half-duplex radio connection or a simplex radio connection;

35 whereby the users of the one or more other mobile stations can listen to the speech transmitted over the full-duplex connection.

According to a second aspect of the present invention, there is provided a mobile radio communications system comprising:

5 a group of call terminating stations all capable of communication with each other, at least some of the stations in the group being mobile radio stations;

means for establishing a full-duplex connection between at least two stations of the group;

10 means for substantially simultaneously establishing half-duplex radio connections and/or simplex radio connections to one or more mobile stations in the group not linked by the full-duplex connection; and

15 means for substantially simultaneously transmitting over said half-duplex connections and/or simplex connections to the other mobile stations in the group the speech transmitted over said full-duplex connection.

In the present invention, the speech signals transmitted over a full-duplex connection between at least two stations of the communication system are
20 retransmitted or broadcast to other mobile radio stations in a group of the system via half-duplex or simplex radio connections. This allows the members of the communication system group to listen to the full-duplex conversation between members of the user group,
25 but without the need to establish full-duplex radio connections to all the mobile stations in the group. The Applicants have recognised that while users may wish to still retain all informed groups together with full-duplex connections, in many cases the users wish only
30 for other members of the group to listen in to such a conversation, rather than for all members of the group to participate in the conversation simultaneously. Thus the present invention meets many users' requirements, while using radio channel capacity relatively
35 efficiently.

The call terminating stations in the group of stations may be any station of the communications system

at which a call terminates (i.e. a subscriber party of the communications system, as distinct from intermediate stations of the communications system such as base stations or sites of a fixed radio communications network). Thus, as well as mobile stations of the mobile radio communications system (to which the communications connections will be radio connections), the group stations could include a fixed line station such as a user of the public switched telephone network (PSTN) or a despatcher having a hard wired connection to the communication system. Typically the group of call terminating stations will include plural mobile radio stations which are in radio communication with the rest of the system.

The group of call terminating stations between which the call is established will typically be a predetermined such group, with its own particular group identity, although this is not necessary. It could alternatively, for example, comprise such a predetermined call group of the radio system and another call terminating station of the system, such as might be the case when a dispatcher wishes to call a call group of mobile stations. In this case, the full-duplex connection would typically be between the other call terminating station and at least one call terminating station of the predetermined call group. As a further alternative, the group of call terminating stations to which the call is established could, for example, be defined dynamically in use.

The full-duplex connection between the group stations can be established as desired, and can conveniently be done in the standard manner for the communication system in question. It may be between any two call terminating stations of the system, such as, for example, a mobile station and a user of the public switched telephone network (PSTN) or a despatcher having a hard wired connection to the communication system

(which would usually naturally have a full-duplex link). The full duplex connection could alternatively be between two mobile stations of the system (in which case the full-duplex connection could be between the mobile stations directly or via a fixed radio communication system network). The Applicants have recognised that there may well be situations where it is desired to have a full duplex call between two mobile stations broadcast to a half-duplex group, rather than simply having a stand-alone half duplex group call. This could be the case, for example, where the mobile station call originators expect to have a full duplex call but it is still desired to have an "all-informed" group.

In a cellular radio system, the full-duplex connection could be between two call-terminating stations in the same cell (served by the same base station), or, more typically, they will be in different cells and served by different base sites or stations.

A full duplex connection may be established between more than two stations of the group, if desired, but this would require more radio resource and increase the signalling complexity. Thus preferably it is between two stations only.

The half-duplex and simplex connections to the mobile radio stations in the group can also be established in any suitable way known in the art. They are preferably only attempted to be established once the full-duplex connection has been established. Most preferably, half duplex connections are used to connect to the mobile radio stations in the group not party to the full duplex connection, since that permits those mobile stations to transmit as well as receive signals whilst participating in the call.

The half-duplex group connection set-up process preferably comprises paging the other, and preferably each of the other, mobile stations in the group with an instruction to establish the half-duplex connection so

that they can receive the call. The set-up process can ask for an acknowledgement from each called party or station before the group call transmission is begun, but preferably no acknowledgements from the receiving group stations are required, as this permits the call to be set up more quickly. In this latter arrangement in particular, the page to the other mobile group members is preferably periodically repeated while the call is taking place to allow any group mobile stations that missed the initial page to join the call subsequently.

Where the radio communications system includes a fixed radio network (which can comprise radio base stations or sites, switching and system management infrastructure, and connections to external networks such as the PSTN, etc, as is known in the art) via which the half-duplex or simplex radio connections to the other mobile radio stations are established, all the mobile stations party to the half-duplex or simplex connections served by the same base station of the fixed radio network preferably receive the retransmitted full duplex speech signals broadcast by the base station on the same radio channel or channels, as this uses radio channel capacity more efficiently. (For the same reason, if a half-duplex mobile station is served by the same base station as a mobile station party to the full duplex call, the half-duplex mobile station can conveniently listen to the downlink signal of the full duplex call, if appropriate).

Where other non-mobile, hard-wired call terminating stations in the group are to listen in to the full-duplex connection they can do so as desired, e.g. via a full duplex connection (which a line will provide) or via a suitably arranged "pseudo half duplex" connection which mimics a half-duplex radio connection over a hard-wired connection, as is known in the art.

A particularly preferred way of implementing the present invention in mobile radio communications systems

which support both full-duplex and half-duplex services, such as the TETRA (TERrestrial Trunked RADio) system, is to set up the call of the present invention using a full-duplex call set-up process and a half-duplex or simplex group call set-up process, with the half-duplex or simplex group call comprising a re-broadcasting of the full-duplex call. Most preferably the arrangement would use the standard full-duplex call set-up and the standard half-duplex or simplex group call set-up process of or defined for the radio system in question. In such an arrangement, a normal full-duplex call would be set-up between two stations in the group, and a separate, normal, half-duplex or simplex group call set-up to all the other group stations. The half-duplex or simplex group call would be a normal one, except that it would be a re-broadcasting of the complete (i.e. both sides of the) full-duplex call. In this arrangement the present invention effectively uses existing services provided by the radio system but in a new manner and combination to provide a new call arrangement that the Applicants have recognised will be advantageous in some circumstances.

Thus according to a third aspect of the present invention, there is provided a method of providing a group call in a mobile radio communications system, comprising:

setting up a full-duplex call between two call terminating stations of the mobile radio communications system; and

setting up a half-duplex group call or a simplex group call to a group of call terminating stations of the mobile radio communications system; wherein said group call comprises a retransmission of speech signals from said full-duplex call.

According to a fourth aspect of the present invention, there is provided a mobile radio communications system comprising:

plural call terminating stations all capable of communication with each other;

means for setting up a full-duplex call between two call terminating stations of the mobile radio communications system; and

means for setting up a half-duplex group call or a simplex group call to a group of call terminating stations of the mobile radio communications system, which group call comprises a retransmission of speech signals from said full-duplex call.

This arrangement preferably uses a modified call request from the user initiating the call which would cause a full-duplex call to be set-up between two stations together with half-duplex or simplex group call connections to the other group stations (which would carry both sides of the full-duplex conversation). Alternatively the call could be implemented as a special service with its own dedicated service identifiers. The call request preferably specifies the group of stations to be called (which could have an identifying label) and the station to be called in full-duplex.

Thus according to another aspect of the present invention, there is provided a call terminating station of a mobile radio communications system, comprising means for making a call request to the system, which call request includes the identification of another call terminating station of the system with which a full-duplex call is to be established, and the identification of a predetermined group of call terminating stations of the system with which a half-duplex group call or a simplex group call is substantially simultaneously to be established.

In the present invention, the speech signals of the full-duplex connection are broadcast to remaining group stations via the half-duplex or simplex connections set up. This speech should be played back by the remaining group stations to their users as a single conversation.

Thus, both (or all) the full duplex speech signals should be mixed before they are played to a listener. This mixing can be done where desired, such as at each receiving station individually (such that each receiving station would receive both halves (or all parts) of the full duplex conversation and then combine them into a single speech signal before playing them).

However, preferably both halves (or all parts) of the full duplex conversation are combined or mixed before transmission to the receiving remaining group stations, e.g. in the fixed radio network infrastructure, such that the receiving stations only receive a single speech signal which they can then play to their user. This reduces the radio channel capacity required for the half-duplex or simplex radio transmissions to mobile radio stations, since only a single speech signal must be transmitted. Also, it ensures that both or all parts of the conversation follow the same radio propagation path to the receiving mobile station.

The speech mixing itself can be performed as desired and in any manner known in the art. It could, for example, be performed in the analogue or digital domains. The mixing could be voice activated as is known in the art.

The group call of the present invention can be terminated as desired. For example, it could be terminated when, or a predetermined period of time after, one or preferably both parties to the full duplex connection have released or cleared the full duplex call.

In a preferred embodiment of the present invention, where the remaining stations in the group are party to half-duplex connections, a listening group member, i.e. one of the remaining stations in the group party to the half-duplex connection, can request to join the full-duplex call or that the full-duplex call be moved to

itself (for example in a mobile radio system by pressing their push-to-talk button). Such requests could be permitted to be made whilst the full-duplex call is ongoing, and/or, for example, during a predetermined time period after one of the original full duplex parties releases the call (thus allowing the call to be picked up by another group member, if desired). The full duplex callers can be alerted to the desire of another group station to interrupt their call by means of an appropriate indication from their stations such as an audible tone.

Where appropriate, the requesting station could be included directly in the full-duplex conversation with the two users presently in full-duplex communication by establishing full-duplex connections between all three parties. However, preferably the new interrupting group member replaces one of the parties to the original full-duplex conversation, such that, in effect, the previous full-duplex call is terminated and a new full-duplex call is established between the new interrupting group members and the remaining original full-duplex party. This saves radio channel resource, and maintains resource allocation in a trunked system whilst still giving the illusion that all members of the group are party to a multi-way full-duplex group call.

Where the call interruption takes place while the full-duplex call is ongoing, the dropping of one of the pre-existing full-duplex connections may be delayed until one of the stations attached via that link has stopped speaking or relinquished the connection (for example by releasing his push-to-talk button (PTT) in a private mobile radio system), i.e. until there is no signal from that station. Alternatively, one of the pre-existing full-duplex connections could be dropped substantially immediately a request is made.

The stations party to the half-duplex connection (i.e. the remaining group members) are preferably

therefore able to make different priority requests to participate in the full-duplex call.

5 A first such request could be a low-priority interrupt (call pre-emption) in response to which the system endeavours to connect the interrupting party to the full-duplex call when possible. For example, a group member could indicate their wish to interrupt by attempting to call one or other or both (e.g. if only equipped for half-duplex) of the stations in the full-
10 duplex conversation, and on call-release by one of the full-duplex users (e.g. releasing PTT) take over.

A second such request could be a higher priority request which forces the communication system to provide the new group member with a full-duplex connection
15 substantially as soon as possible (i.e. to force one of the two stations to move from the full-duplex connection substantially immediately). For example, a group member could call one or both of the stations in the full-duplex conversation with a higher priority status set
20 such that one or other of them is forced to relinquish their connection as soon as possible in favour of a full-duplex connection with the calling group station.

The pre-existing full-duplex connection to be replaced is preferably selected by using one or more,
25 preferably predetermined, arbitration criteria. For example, it could be determined by which user invoked the original call (such that, e.g. the original call initiator is retained under all circumstances), by which original user was the last party to speak, by which
30 party released their channel first, in accordance with a predetermined priority list (e.g. such that the connection with lowest priority is terminated) or a combination of such factors. In the penultimate case it may be further arranged that the station making the call
35 request will not be allowed access if it has a lower priority than the two pre-existing parties to the full-duplex call, or such that it gets access anyway in place

of the current party having the lowest priority.

These arbitration criteria could also be used to determine which of a plurality of group members who seek to interrupt the full-duplex call simultaneously becomes a party to the full-duplex call. It could also be arranged such that not all stations in the group have the facility to interrupt the full-duplex call.

Preferably, the arrangement is such that a new speaker has a minimum call duration as a party to the full-duplex call before he is able to be replaced by another group member.

As will be appreciated by those skilled in the art, a group call set up in accordance with the present invention can be restricted to a single cell or base station of a mobile radio communications system, or may extend over one or more cells of the mobile radio communications system, such that one or more base sites are involved in setting up and handling the call. In any event, it is probable that at least one base station will be involved in a full duplex radio connection with one mobile station and a half duplex or simplex radio connection with one or more second mobile stations participating in the group call.

Thus, according to a yet further aspect of the present invention, there is provided a radio communications station for use in a mobile radio communication system which includes a plurality of mobile stations, the communications station comprising:

means for establishing full-duplex radio communication between the station and a first mobile radio station of the radio communications system;

means for establishing half-duplex radio communication or simplex radio communication between the station and one or more other mobile stations of the radio communication system; and

means for transmitting both the speech signal transmitted to and the speech signal received from the

first mobile station substantially simultaneously to said other mobile stations of the radio communication system via said half-duplex or simplex radio communication connection or connections.

5 This radio communications station would typically be a fixed base station of the radio communication system, but this is not essential. It could also comprise a suitably equipped mobile station, such as a mobile radio or phone (whether vehicle mounted or
10 portable).

 The communications station of this aspect of the present invention preferably further includes means for mixing the speech signals received and transmitted over the full duplex connection to form a single speech
15 signal which is then transmitted over the half-duplex connections.

 If desired the call set up process of the present invention can include a step of checking initially if radio or other resource and/or call participants
20 necessary for the call is available, and if it is not blocking the call and so informing the call originator. Otherwise, the call set up process would then proceed as described above.

 The methods in accordance with the present invention may be implemented at least partially using software e.g. computer programs. It will thus be seen
25 that when viewed from further aspects the present invention provides computer software specifically adapted to carry out the methods hereinabove described when installed on data processing means, and a computer
30 program element comprising computer software code portions for performing the methods hereinabove described when the program element is run on a computer. The invention also extends to a computer software
35 carrier comprising such software which when used to operate a radio system or a radio communications station comprising a digital computer causes in conjunction with

said computer said system or station to carry out the steps of the method of the present invention. Such a computer software carrier could be a physical storage medium such as a ROM chip, CD ROM or disk, or could be a signal such as an electronic signal over wires, an optical signal or a radio signal such as to a satellite or the like.

It will further be appreciated that not all steps of the method of the invention need be carried out by computer software and thus from a further broad aspect the present invention provides computer software and such software installed on a computer software carrier for carrying out at least one of the steps of the methods set out hereinabove.

A preferred embodiment of the present invention will now be described by way of example only, and with reference to the accompanying drawings, in which:

Figure 1 shows a block schematic diagram of a mobile radio communications system in accordance with the present invention,

Figure 2 shows the system of Figure 1 configured in a different manner, and

Figure 3 shows schematically the setting up of a group call in accordance with the present invention in a time division multiple access (TDMA) mobile radio system.

In the figures the same reference numerals have been used to identify corresponding features.

Figure 1 shows a Trunked Private Mobile Radio (PMR) system including a fixed radio network which includes base stations PS1, PS2 and PS3 linked by fixed connections such as, for example, land line or microwave connections. (While three base stations are shown in the Figures, it will be understood that the radio system may comprise only one or any number of such stations.) Seven mobile stations SS1 - SS7 are shown in radio communication with the base stations.

In the arrangement shown in Figure 1 a group call in accordance with the present invention has been set up. In this call, mobile stations SS2 and SS7 are having the full-duplex call, and all the remaining
5 mobile stations are listening in over half-duplex connections. Thus, mobile station SS2 has, as shown, a full-duplex connection to base station PS1 and mobile station SS7 has a full-duplex connection to base station PS3, such that mobile stations SS2 and SS7 have
10 effectively a full duplex connection (via the fixed radio network) to each other.

The remaining mobile stations have half-duplex radio connections to the network so that they can listen into the full duplex call between mobile stations SS2
15 and SS7. Thus, mobile station SS1 has a half-duplex connection to base station PS1, mobile station SS3 and mobile station SS4 have a half-duplex connection with base station PS2, and mobile station SS5 and mobile station SS6 have a half-duplex connection with base
20 station PS3.

The radio system operates to rebroadcast the speech signals from mobile stations SS2 and SS7 over the half-duplex radio connections to the remaining mobile stations in the group, so that those mobile stations can
25 listen in to the full duplex call and hear both sides of the conversation, i.e. hear both call terminating stations, mobile station SS2 and mobile station SS7. The speech signals can be transmitted on two half-duplex channels to each mobile station (i.e. with each channel carrying the signal received from mobile station SS2 and
30 mobile station SS7, respectively), where they are then mixed. Alternatively the fixed radio network can mix the speech signals which are then transmitted as a single half-duplex channel to each receiving mobile
35 station.

The mobile stations having half-duplex connections to the same base station can listen and receive on

separate channels, but preferably they will, as would normally be the case, receive, i.e. listen to, the same channel (i.e. effectively share the same channel) as this saves radio resource.

5 While the communication system is illustrated as having only mobile stations as call terminating stations, it could also include other such stations such as a standard telephone user connected to the PSTN or a dispatcher connected by wire to the mobile radio system.
10 The means by which such users are connected to a mobile radio system are well known. These other stations could be party to the full-duplex call or the half duplex group broadcast, in the same way as the mobile stations.

15 Figure 3 is a chart whose X-axis is time which shows the sequence of events necessary to set up the group call shown in Figure 1 in a TDMA (time division multiple access) radio system such as the TETRA system. It should be noted that the invention can be implemented in systems other than TETRA.

20 The four lines of time slots in Figure 3 relate to the transmission activity of mobile station SS2, the fixed radio network (in this case base stations PS1, PS2 and PS3 - it is assumed in this example that these three base stations are synchronised, but this is, as is known
25 in the art, not essential), mobile station SS7 and the collective group (GRP) respectively (comprising in this example mobile stations SS1, SS3-SS6). It is assumed that mobile station SS2 wishes to initialise a group call. The arrows marked 'T' followed by a number,
30 indicate points in time at which events occur and are referred to below. It should be noted that Figure 3 shows the minimum possible timings for the various events and thus assumes instantaneous responses, etc., from called stations, and so, for example, in practice
35 the events may occur at greater timing intervals than those shown in Figure 3.

At time T1 the user of mobile station SS2 presses

his push-to-talk (PTT, sometimes called a pressel) button. Mobile station SS2 makes a random access to base station PS1 (i.e. the fixed radio network) on a control or signalling channel (e.g. TETRA Main Control Channel (MCCH)) as soon as feasible at time T2 to request that the call be set up. The signal sent by mobile station SS2 comprises a call setup request that identifies the request as relating to a duplex call with mobile station SS7 and a group call with the appropriate fully informed group. It could, for example, be the combination of the usual system duplex call and group call signalling. Alternatively a separate signalling message for the group calls of the present invention could be provided.

At time T3, base station PS1 acknowledges the request to mobile station SS2 and issues a page (via other base stations if necessary and in this case via base station PS3) to mobile station SS7 to indicate that mobile station SS7 is being called. Mobile station SS7 then indicates to its user that they are being called. The user then "picks up" the call by pressing his PTT or "off-hook" button. Only after this, at time T5, does mobile station SS7 acknowledge the page message to the base station.

At time T6 the base station PS1 instructs mobile station SS2 to go to the traffic channel allocated for the call, confirms the channel to mobile station SS7 (T6a) and issues a page message (T6b) to the group (to set up the half-duplex connection to the group members).

At time T7, those members of the group that received the paging signal from the base station change channel to monitor the call. Page messages to the rest of the group are thereafter periodically issued to give a higher success probability for paging the group members.

At time T8 the mobile stations SS2 and SS7 can, if necessary, linearise their transmitters (e.g. using

transmissions on the common linearisation channel in TETRA). (This step is only necessary in TETRA where the Main Control Channel is not on the same frequency as the allocated traffic channel.)

5 At time T9, mobile station SS2 and mobile station SS7 confirm their presence on the traffic channel. Depending on the radio system a dummy burst may be transmitted at time T10 by the base station to mobile stations SS2, SS7 (at time T10a) and to the group (at
10 time T10b) until speech transmission begins. At time T11 the two mobile stations SS2, SS7 having the full duplex link transmit to one another and at T12 the base station(s) transmit both sides of the call to the reminder of the group over the half-duplex connections
15 established.

 Consider now the situation where mobile station SS3 wishes to speak to mobile station SS2 in an ongoing call as shown in Figure 1. Mobile station SS3 would first transmit a call pre-emption request to the radio
20 communications system. A request to relinquish its full-duplex status is then, for example, sent by the fixed radio network to mobile station SS7. When the user of mobile station SS7 releases the call (e.g. by releasing their PTT or pressing their "on-hook" button),
25 call transfer proceeds and mobile station SS3 is allocated the duplex channel that was previously allocated to mobile station SS7.

 The communications system is then configured as shown in Figure 2. Mobile station SS3 now has a full-
30 duplex link with base station PS2 and mobile station SS7 now has a half-duplex link with base station PS3 (it shares a channel with mobile station SS6). The other connections are the same as shown in Figure 1. In this arrangement mobile stations SS2 and SS3 now have the
35 full-duplex call, with the other stations listening in.

 In an alternative arrangement the mobile station that wishes to take part in the call may issue a

priority call pre-emption request which the communication system tries to satisfy substantially immediately by forcing one of SS2 and SS7 from the full-duplex call. It may be desired not to provide all of the mobile stations with this facility. Indeed a number of priority requests relating to different levels of urgency may be provided if desired and allocated to all of the mobile stations. Instead they could be allocated only to certain mobile stations, for example according to the seniority of the user of the station within the organisation that uses the mobile radio system.

The call can be cleared and terminating as desired, e.g. by the full-duplex connected stations indicating their desire to clear the call to the radio system infrastructure and the radio system infrastructure then instructing all stations to clear the call, or by the radio system infrastructure instructing all stations to clear the call upon expiry of a call timer associated with the call.

The present invention can be arranged to operate on any mobile radio system that provides a full duplex service and group addressing functions, such as a suitable private mobile radio system or cellular mobile phone system. The invention is not restricted to a digital TDMA system as described here but may be implemented with any digital system and/or with an analogue system that provides addressing.

Claims:

1. A method of establishing a call between a group of call terminating stations of a mobile radio communications system, where at least some of the stations in the group are mobile radio stations, comprising:
 - setting up a full-duplex connection between at least two stations in the group; and
 - retransmitting speech transmitted over the full-duplex connection to one or more mobile radio stations in the group not linked by the full-duplex connection via a half-duplex radio connection or a simplex radio connection, whereby the users of the one or more other mobile stations can listen to the speech transmitted over the full-duplex connection.
2. The method of claim 1, wherein the full-duplex connection is between two mobile radio stations of the system.
3. The method of claim 1 or 2, wherein the half-duplex or simplex connections to the mobile radio stations in the group are only attempted to be established once the full-duplex connection has been established.
4. The method of claim 1, 2, or 3, wherein half-duplex connections are used to connect to the mobile radio stations in the group not party to the full duplex connection.
5. The method of claim 1, 2, 3, or 4, wherein the half-duplex and/or simplex connection set-up process comprises paging the other mobile stations in the group with an instruction to establish the half-duplex and/or simplex connection so that they can receive the call.

6. The method of claim 5, wherein the page to the other mobile stations in the group is periodically repeated while the call is taking place to allow any group mobile stations that missed the initial page to
5 join the call subsequently.

7. The method of any one of the preceding claims, wherein the radio communications system includes a fixed radio network comprising radio base stations via which
10 the half-duplex or simplex radio connections to the other mobile radio stations are established, and wherein all of the mobile stations party to the half-duplex or simplex connections served by the same base station of the fixed radio network receive the retransmitted full
15 duplex speech signals broadcast by the base station on the same radio channel or channels.

8. The method of any one of the preceding claims, wherein the full duplex connection is set up using the
20 standard full-duplex call set-up process of the radio system, and the half-duplex and/or simplex radio connections are set-up using the standard half-duplex group call and/or simplex group call set-up process of the radio system.

25

9. A method of providing a group call in a mobile radio communications system, comprising:

30 setting up a full-duplex call between two call terminating stations of the mobile radio communications system; and

setting up a half-duplex group call or a simplex group call to a group of call terminating stations of the mobile radio communications system; wherein

35 said group call comprises a retransmission of speech signals from said full-duplex call.

10. The method of claim 8 or 9, wherein the user

initiating the call uses to do so a call request that specifies the group of call terminating stations to be called and the call terminating station to be called in full-duplex.

5

11. The method of any one of the preceding claims, wherein all parts of the full duplex conversation are combined or mixed into a single speech signal before retransmission to the remaining group stations.

10

12. The method of any one of the preceding claims, wherein call terminating stations in the group party to a half-duplex or simplex connection can request to participate in the full-duplex connection.

15

13. The method of claim 12, wherein the requesting station replaces one of the parties to the existing full-duplex connection when the request to participate in the full-duplex connection is granted.

20

14. The method of claim 13, wherein the existing full-duplex connection party to be replaced is selected by using one or more predetermined selection criteria.

25

15. The method of any one of claims 12 to 14, wherein stations party to a half-duplex or simplex connection are able to make requests to participate in the full-duplex connection of differing priorities.

30

16. The method of any one of claims 12 to 15, wherein stations party to a half-duplex or simplex connection are able to make a high priority request to participate in the full-duplex connection, in response to which request the communications system provides the

35

requesting station with a full-duplex connection substantially as soon as possible.

17. The method of any one of claims 12 to 16, wherein a new party to the full-duplex connection has a minimum call duration as a party to the full-duplex connection before it is able to be replaced by another group station.

18. A mobile radio communications system comprising:
a group of call terminating stations all capable of communication with each other, at least some of the stations in the group being mobile radio stations;
means for establishing a full-duplex connection between at least two stations of the group;
means for establishing half-duplex radio connections and/or simplex radio connections to one or more mobile stations in the group not linked by the full-duplex connection; and
means for substantially simultaneously transmitting over said half-duplex connections and/or simplex connections to the other mobile stations in the group speech transmitted over said full-duplex connection.

19. The system of claim 18, wherein the full-duplex connection is between two mobile radio stations of the system.

20. The system of claim 18 or 19, wherein the half-duplex or simplex connections to the mobile radio stations in the group are only attempted to be established once the full-duplex connection has been established.

21. The system of claim 18, 19 or 20, further comprising means for paging mobile stations in the group with an instruction to establish the half-duplex or simplex connection so that they can receive the call.

22. The system of any one of claims 18 to 21, wherein

the means for establishing a full-duplex connection comprises means for setting up the full duplex connection using the standard full-duplex call set-up process of the radio system, and the means for
5 establishing half-duplex and/or simplex radio connections comprise means for setting up a half-duplex and/or simplex radio connection using the standard half-duplex group call or simplex group call set-up process of the radio system.

10

23. A mobile radio communications system, comprising:
plural call terminating stations all capable of communication with each other;

15 means for setting up a full-duplex call between two call terminating stations of the mobile radio communications system; and

20 means for setting up a half-duplex group call or a simplex group call to a group of call terminating stations of the mobile radio communications system which comprises a retransmission of speech signals from said full-duplex call.

24. The system of claim 22 or 23, wherein the call terminating stations comprise means for making a call
25 request that specifies the group of call terminating stations to be called and the call terminating station to be called in full-duplex.

25. The system of any one of claims 18 to 24, further
30 comprising means for combining or mixing all parts of the full duplex conversation into a single speech signal before transmission to the remaining group stations.

26. The system of any one of claims 18 to 25, wherein
35 call terminating stations in the group comprise means for making a request to participate in the full-duplex connection.

27. The system of claim 26, comprising means for replacing one of the parties to the existing full-duplex connection with the requesting station when the request to participate in the full-duplex connection is granted.

5

28. The system of claim 27, comprising means for selecting the existing full-duplex connection party to be replaced on the basis of one or more predetermined selection criteria.

10

29. The system of any one of claims 26 to 28, wherein stations party to a half-duplex or simplex connection comprise means for making requests to participate in the full-duplex connection of differing priorities.

15

30. A call terminating station of a mobile radio communications system, comprising means for making a call request to the system, which call request includes the identification of another call terminating station of the system with which a full-duplex call is to be established, and the identification of a predetermined group of call terminating stations of the system with which a half-duplex group call or a simplex group call is substantially simultaneously to be established.

25

31. A radio communications station for use in a mobile radio communication system which includes a plurality of mobile stations, the communications station comprising:

30 means for establishing full-duplex radio communication between the station and a first mobile radio station of the radio communications system;

35 means for establishing half-duplex radio communication or simplex radio communication between the station and one or more other mobile stations of the radio communication system; and

means for transmitting substantially simultaneously to said other mobile stations of the radio communication

system via said half-duplex or simplex radio communication connection or connections speech signals transmitted to and received from the first mobile station.

5

32. The radio communications station of claim 31, wherein the radio communication station comprises a base station of the mobile radio communications system.

10

33. The radio communications station of claim 31 or 32, further comprising means for mixing or combining the speech signals received and transmitted over the full duplex connection to form a single speech signal for transmission over the half-duplex or simplex connection or connections.

15

34. A computer program element comprising computer software code portions for performing the method of any one of claims 1 to 17 when said program element is run on a computer.

20

35. A method of establishing a call between a group of call terminating stations of a mobile radio communications system substantially as hereinbefore described with reference to any one of the accompanying drawings.

25

36. A mobile radio communications system substantially as hereinbefore described with reference to any one of the accompanying drawings.

30

37. A call terminating station of a mobile radio communications system substantially as hereinbefore described with reference to any one of the accompanying drawings.

35

38. A radio communications station substantially as

hereinbefore described with reference to any one of the accompanying drawings.



Application No: GB 9929053.8
Claims searched: 1 to 34

Examiner: Jared Stokes
Date of search: 9 March 2000

Patents Act 1977
Search Report under Section 17

Databases searched:

UK Patent Office collections, including GB, EP, WO & US patent specifications, in:
UK Cl (Ed.R): H4L (LDM)
Int Cl (Ed.7): H04Q (7/28)
Other: On-Line - WPI, EPODOC

Documents considered to be relevant:

Category	Identity of document and relevant passage	Relevant to claims
Y	WO 97/50266 A2 (Qualcomm) See page 5 lines 33-34	17
X,Y	US 5 506 837 (Söllner et al.) See column 7 lines 10-25	X:1-4, 7-13, 18-20, 22-27, 30-34 Y: 17

X	Document indicating lack of novelty or inventive step	A	Document indicating technological background and/or state of the art.
Y	Document indicating lack of inventive step if combined with one or more other documents of same category.	P	Document published on or after the declared priority date but before the filing date of this invention.
&	Member of the same patent family	E	Patent document published on or after, but with priority date earlier than, the filing date of this application.