



12 **EUROPEAN PATENT APPLICATION**

21 Application number: **90309750.9**

51 Int. Cl.<sup>5</sup>: **E21B 43/1185, E21B 43/116**

22 Date of filing: **06.09.90**

30 Priority: **06.09.89 US 404029**

71 Applicant: **HALLIBURTON COMPANY**  
**P.O. Drawer 1431**  
**Duncan Oklahoma 73536(US)**

43 Date of publication of application:  
**13.03.91 Bulletin 91/11**

72 Inventor: **George, Kevin R.**  
**P.O. box 172**  
**Columbus, Texas 78934(US)**

84 Designated Contracting States:  
**DE FR GB IT NL**

74 Representative: **Wain, Christopher Paul et al**  
**A.A. THORNTON & CO. Northumberland**  
**House 303-306 High Holborn**  
**London WC1V 7LE(GB)**

54 **Time delay perforating apparatus for wells.**

57 Apparatus for perforating a well comprises at least one first gun (20) and second gun (22) with a time delay device (50) positioned therebetween in a housing (24) connecting first and second guns. The time delay device delays firing of the second gun (22) for a predetermined period after firing of the first gun (20) and also preferably prevents fluid communication between the first and second guns by closing off a central opening (26) through the housing.

## TIME DELAY PERFORATING APPARATUS FOR WELLS

This invention relates to apparatus for perforating a well bore and, more particularly, to an apparatus for firing at least two guns with a predetermined time delay in between.

In well bore perforating operations, it is important for the operator to know whether or not all the guns have been fired. Typically, a time delay device is positioned at the bottom of the string below the lowermost guns. The explosive output of one gun fires the next lower gun, and this continues with the lowermost gun triggering the time delay device. The time delay device has a relatively slow burning material in it, and after this material burns, a small explosive charge in the time delay device is detonated.

At the surface, the operator can hear and feel the guns firing, and after the guns cease firing, the operator listens for the detonation of the time delay device. If he hears it, he knows all of the guns have fired since the time delay device cannot be actuated otherwise.

One problem with this prior known apparatus is that, depending upon the depth and conditions of the well, the ignition of the small charge in the time delay device may not be heard. If this is the case, then the operator does not know if the last gun has fired.

In our U.S. patent specification no. 4,478,294, a time delay device is positioned above the lower one or two guns in the string. The firing of the last gun is thus delayed. The firing of the last gun is significantly louder, and thus more easily discerned, than the detonation of the small charge in the prior art time delay device because the charge in the perforating guns is considerably larger. Electrical sensors may also be provided to monitor the firing of the guns.

We have now devised an improved apparatus of this type wherein a time delay device is positioned between upper perforating guns and at least the lowermost perforating gun, and wherein a housing is positioned between the guns for receiving the time delay device.

According to the present invention, there is provided an apparatus for perforating a well bore, said apparatus comprising: an upper gun adapted for connecting to a tool string; housing means for connecting to said upper gun, said housing means defining a housing central opening therethrough; a lower gun connected to said housing means; and a time delay device in said housing means for delaying firing of one of said upper and lower guns for a predetermined period of time after firing of the other of said upper and lower guns.

Another problem with certain prior art perforat-

ing tools is that once some of the guns have fired, fluid is free to enter all of the guns therebelow. If all the guns do not fire, the fluid in the lower guns makes retrieval more difficult. Also, the entire tool must be broken down and drained in order to re-use the lower guns. In a preferred arrangement of the present invention, the time delay device prevents fluid communication between the upper guns and the gun or guns below the time delay device. This allows the time delay device and the guns therebelow to be re-run by simply replacing the portions of the perforating string thereabove. It is not necessary to break down the apparatus and drain it. In fact, the apparatus of the present invention could be run in multiple positions in a perforating string with each location acting as a fluid isolation device to prevent fluid entry into the lower guns in the event of a "stop-fire" (misfire).

Prior art systems have included fluid isolation shims which perform this function, but the shims are not compatible with all the firing devices and therefore are not usable in all situations.

The housing means connects the upper and lower perforating guns and houses the time delay device for delaying the firing of one of the guns. The time delay means is characterised in a preferred embodiment by a time delay device disposed in the housing means. The housing means defines a housing central opening therethrough, and the apparatus preferably comprises sealing means for sealing between the time delay means and the housing central opening.

The time delay device preferably comprises a primer assembly, firing means, such as a firing pin, for impacting and thereby detonating the primer assembly, a time delay mix triggered by detonation of the primer assembly, and explosive means for providing an explosive force which is triggered by the time delay mix. Preferably, an ignition mix is used between the primer assembly and time delay mix. All of these components are positioned in a body central opening defined in a time delay body. The explosive means is a primary explosive ignitable by the delay mix and a secondary explosive ignitable by the primary explosive.

An upper retainer is preferably engaged with the body for at least partially closing an upper end of the body central opening, and a lower retainer is provided for at least partially closing a lower end of the body central opening. A screen may be disposed between the primer assembly and the delay mix. The firing pin is preferably shearably positioned in the body and has a shearable flange which engages a shoulder in the body. Preferably, a sealing means is provided for sealing between

the firing pin and the body central opening.

In order that the invention may be more fully understood, reference is made to the accompanying drawings, wherein:

FIG. 1 illustrates one embodiment of perforating apparatus of the present invention in position in a well bore at the end of a tool string;

FIG. 2 is an enlarged cross-sectional detail of the portion of the tool string which holds the time delay device; and

FIG. 3 is a longitudinal cross section of an embodiment of time delay device.

Referring now to the drawings, and more particularly to Fig. 1, the perforating apparatus of the present invention is shown and generally designated by the numeral 10. Apparatus 10 is connected to the lower end of a tool string 12 and is positioned in a well bore 14 which may or may not have a casing 16. Apparatus 10 is positioned adjacent to a formation 18 to be perforated.

Apparatus 10 includes at least one first or upper gun 20 and at least one second or lower gun 22. In the preferred embodiment, there will be a plurality of upper guns 20 and a relatively fewer number of lower guns 22. The invention requires at least one lower gun, but more may be used. While guns 20 have been referred to as upper guns, and guns 22 have been referred to as lower guns, it will be understood by those skilled in the art that the guns could be reversed. That is, the firing sequence could be from bottom to top with the uppermost gun being fired after the time delay, rather than fired from top to bottom with the lowermost gun being fired after the time delay. A more detailed description of the firing sequence is provided herein.

Referring now also to FIG. 2, a time delay housing means 24 is disposed between upper and lower guns 20 and 22. In a preferred embodiment, housing means 24 is characterized by an elongated housing 24 defining a longitudinal housing central opening 26 therein.

The upper end of housing 24 is connected to an upper gun 20 at threaded connection 28. Sealing means, such as O-rings 30, provide sealing engagement between the housing and lower gun.

The lower end of housing 24 is attached to lower gun 22 at threaded connection 32 with a sealing means, such as O-rings 34, therebetween.

Housing central opening 26 includes a first bore 36, a slightly larger second bore 38, and an even larger third bore 40 in housing 24. A generally annular, downwardly facing shoulder 42 extends between first and second bores 36 and 38, and another generally annular downwardly facing shoulder 44 extends between second bore 38 and third bore 40. A tapped bore 46 extends outwardly away from the lower end of third bore 40.

A time delay device 50 is positioned in central opening 26 of housing 24 and closes off the housing central opening as best shown in FIG. 2. Sealing means, such as a pair of O-rings 52, provide sealing engagement between time delay device 50 and third bore 40 of housing 24. A detonation or primer cord 54 extends downwardly from the explosive portion (not shown) of upper gun 20 and into contact with time delay device 50, as will be further discussed herein.

Referring now to FIG. 3, tee details of time delay device 50 are shown. Time delay device 50 includes an elongated body 56 having an outer surface 58 adapted to fit closely within third bore 40 of housing 24. An upper end 60 of body 56 is positioned adjacent to shoulder 44 in housing 24. A pair of annular grooves 62 in outer surface 58 receive O-rings 52 therein.

Body 56 defines a body central opening 64 therethrough. Body central opening 64 includes a first threaded opening 66 adjacent to upper end 60, a first bore 68, a somewhat smaller second bore 70, and a second threaded opening 72 at the lower end of second bore 70. A generally annular upwardly facing shoulder 74 extends between first and second bores 68 and 70 in body 56.

A firing pin housing 76 is disposed in the upper portion of body central opening 64 in body 56 and has a threaded portion 78 engaged with threaded opening 66 and a lower portion 80 which extends into first bore 68 in close relationship therewith. Sealing means, such as O-rings 82, provide sealing engagement between firing pin housing and first bore 68.

Firing pin housing 76 has a bore 84 therein with a counterbore 86 at an upper end thereof such that an annular, upwardly facing shoulder 88 is formed. The bottom of firing pin housing 76 has a hole 90 therethrough which is somewhat smaller than bore 84.

A firing means, such as a firing pin 92, is disposed in firing pin housing 76. A central portion 94 of firing pin 92 fits closely within bore 84. Sealing means, such as O-rings 96, provide sealing engagement between firing pin 92 and bore 84. It will thus be seen that firing pin housing 76 and firing pin 92 close off body central opening 64, and it may be generally said that the firing means closes off the body central opening.

At the upper end of firing pin 92 is a shearable flange 98 which fits in counterbore 86 and rests on shoulder 88 initially. As will be discussed in more detail herein, flange 98 will be sheared when exposed to the explosive output of gun 20 thereabove.

At the lower end of firing pin 92 is pin portion 100 which is sized to fit within hole 90 in firing pin housing 76.

Disposed below firing pin housing 76 in first bore 68 of body 56 is a primer assembly 102. Primer assembly 102 is of a kind known in the art and is adapted for detonation upon impact by pin portion 100 of firing pin 92. One such primer assembly comprises titanium potassium perchlorate ( $TiKClO_4$ ).

A primer retainer 104 is disposed in first bore 68 of body 56 below primer assembly 102. Primer retainer 104 defines a central opening 106 therethrough.

A disc-like screen 108 having a plurality of holes 110 therein is positioned between primer retainer 104 and shoulder 74 in body 56.

Firing pin housing 76, firing pin 92, primer assembly 102, primer retainer 104 and screen 108 are clamped in the position shown in FIG. 3 by an upper retainer 112 which has a threaded portion 114 engaged with threaded opening 66 in body 56. Upper retainer 112 defines a central opening 116 therein which is adapted for receiving a lower end of detonation cord 54.

The present invention includes explosive means disposed in second bore 70 of body 56 below screen 108. The explosive means comprises several components in the preferred embodiment.

Immediately below screen 108 is an ignition mix 116, such as an AIA element.

Below ignition mix 116 is a time delay means 118, such as a time delay mix 118. A tungsten material is used in time delay mix 118 in the preferred embodiment, although the invention is not intended to be limited to tungsten. As is known in the art, the tungsten material is in powdered form, and a small portion is poured into second bore 70 of body 56 and compressed to form a tungsten increment 120. Additional tungsten increments 120 are formed in the same way so that a series of such increments are adjacent to one another in second bore 70 as seen in FIG. 3. By varying the quantity of tungsten material and the amount of compression of the powder which affects the density thereof different burn rates of time delay mix 118 are obtained.

Below time delay mix 118 is a primary explosive 122. In the preferred embodiment primary explosive 122 comprises a titanium potassium perchlorate ( $TiKClO_4$ ) element 124 and a lead azide element 126. Lead azide element 126 is encapsulated in a small cup 128.

Below primary explosive 122 is a secondary explosive 130 which preferably comprises a PYX charge 132 in an output cup 134. Lead azide element 126 and small cup 128 are also disposed in output cup 128 but are still generally considered part of primary explosive 122 rather than secondary explosive 130.

A lower retainer 136, having a threaded portion

138 engaged with second threaded opening 76 in body 56, holds ignition mix 116, time delay mix 118, primary explosive 122 and secondary explosive 130 in place. Lower retainer 136 defines a hole 140 therein which is in communication with lower gun 22.

### Operation

After apparatus 10 is positioned as desired in well bore 14, upper guns 20 are triggered in any manner known in the art, and as also known in the art, sequentially fire one another. The speed of this downward sequence is typically on the order of about 2440m (8000 feet) per second. This is much too fast for the operator to tell how many guns have fired.

When the lowermost one of guns 20 is fired, it ignites detonation cord 54 which provides an explosive force against the upper end of firing pin 92. This force is sufficient to shear flange 98 so that firing pin 92 is moved downwardly until pin portion 100 thereof impacts primer assembly 102. Primer assembly 102 is thus detonated and the explosive forces directed downwardly through central opening 106 in primer retainer 104 and through holes 110 in screen 108 to ignite ignition mix 116.

The heat from ignition mix 116 starts the burning of time delay mix 118. The number and density of time delay increments 120 is preselected so that a predetermined period of time is required for time delay mix 118 to completely burn, usually about 10 seconds, although any time may be selected. Once this time has passed, titanium potassium perchlorate element 124 is detonated by the burning of time delay increments 120. The output of element 124 in turn ignites lead azide element 126. Thus, in the preferred embodiment, two components of primary explosive 122 are used.

The explosion from element 126 detonates PYX charge 132 of secondary explosive 130. The explosive output of secondary explosive 130 is directed downwardly through hole 140 in lower retainer 136 and into lower gun 22. This explosive force from secondary explosive 130 then triggers lower guns 22. The actual ignition of lower guns 22 is known in the art.

Thus, the operator at the surface fires the upper guns which quickly and sequentially fire until time delay device 50 is actuated. Because of the time delay and burning of time delay elements 120 in time delay means 118, the explosive force necessary to trigger lower guns 22 is thus delayed by the predetermined amount. When lower guns 22 do fire, the significant noise and vibration resulting there from is observed by the operator to occur

this predetermined time after the firing of upper guns 20. In this way, the operator knows that all of the guns have fired because lower guns 22 fired. If all of upper guns 20 do not fire, then time delay device 50 is never actuated, and the operator will know that the perforation operation is incomplete because the time delayed firing of lower guns 22 does not occur. As already noted, the tool can be inverted so that the firing sequence is from bottom to top rather than top to bottom. The components described herein would be the same for such an orientation except that each of those components normally would be inverted as well.

Once any of upper guns 20 are fired, fluid is free to enter the tool string through those guns. All of upper guns 20 are in fluid communication with one another, and they thus become filled with fluid. However, the time delay device 50 positioned in housing 24 blocks any fluid communication between upper guns 20 and lower guns 22. In the event of misfire of upper guns 20, lower guns 22 will not be flooded with fluid. Thus, if the tool string is retrieved, it is only necessary to replace the components above time delay device 50. The time delay device and all of the components therebelow may be reused without the necessity of disassembly with cleaning or replacement of parts. This feature of the present invention therefore provides a means of fluid isolation on long gun intervals.

Several of housings 24 with time delay devices 50 therein could be positioned along the perforating string to isolate the guns below each time delay device from the guns thereabove. Thus, in addition to the time delay benefits, this fluid isolation benefit saves considerable time in retrieving and refitting a perforating string in which there has been a misfire, and also insures the reuse of components which would otherwise have to be disassembled with some items replaced.

It will be seen, therefore, that the time delay perforating apparatus of the present invention is well adapted to carry out the ends and advantages mentioned as well as those inherent therein. While a presently preferred embodiment of the invention has been described for the purposes of this disclosure, numerous changes in the arrangement and construction of parts may be made by those skilled in the art. In particular, but not by way of limitation, different explosive compositions may be used for the various components in addition to the specific compounds cited.

## Claims

1. Apparatus for perforating a well bore, said apparatus comprising: an upper gun (20) adapted for connecting to a tool string (12); housing means (24)

for connecting to said upper gun, said housing means defining a housing central opening (26) therethrough; a lower gun (22) connected to said housing means; and a time delay device (50) in said housing means for delaying firing of one of said upper and lower guns for a predetermined period of time after firing of the other of said upper and lower guns.

2. Apparatus according to claim 1, wherein said time delay device comprises a primer assembly (102); a firing pin (92) for detonating said primer assembly; a time delay mix (118); explosive means (122,132) for providing an explosion which is triggered by said time delay mix.

3. Apparatus according to claim 2, wherein said explosive means comprises a primary explosive (122) and a secondary explosive (132).

4. Apparatus according to claim 3, wherein said primary explosive (122) comprises at least one of titanium potassium perchlorate and lead azide.

5. Apparatus according to claim 3 or 4, wherein said secondary explosive (132) comprises PYX.

6. Apparatus according to claim 2,3,4 or 5, further comprising an ignition mix (116) between said primer assembly (102) and said time delay mix (118).

7. Apparatus according to any of claims 1 to 6, wherein said time delay device (50) is removable from said housing means (24).

8. Apparatus according to any of claims 1 to 7, wherein said time delay device (50) is disposed in said housing central opening (26) such that fluid flow through said housing central opening is prevented.

9. A method of perforating a well bore wherein there is used an apparatus as claimed in any of claims 1 to 8.

5

10

15

20

25

30

35

40

45

50

55

5

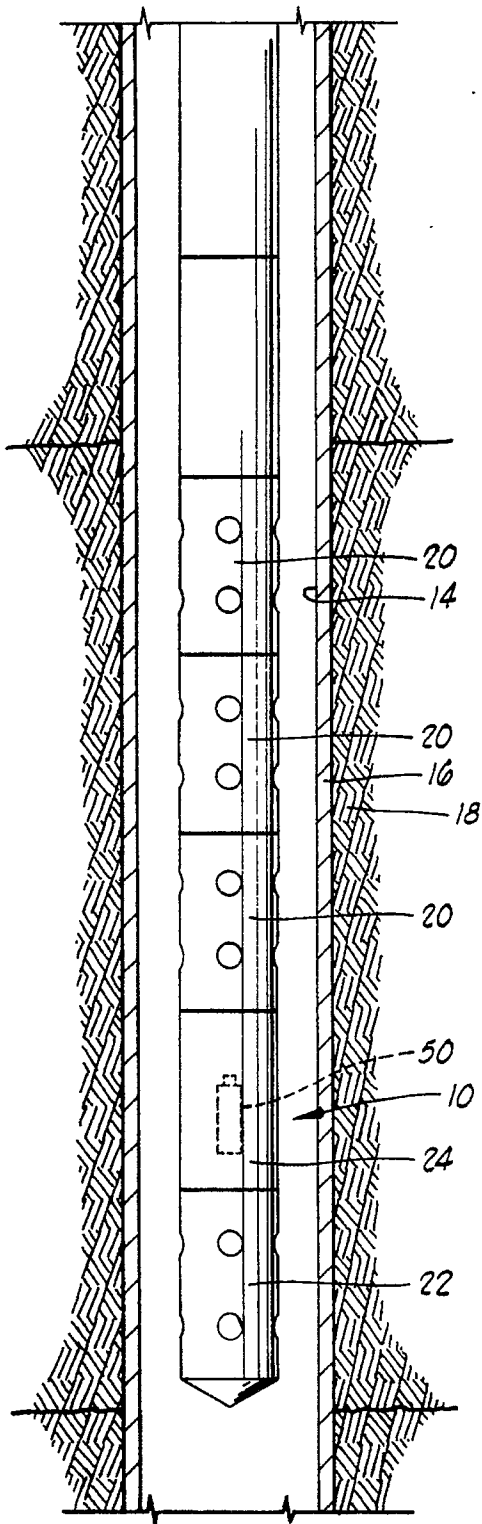

FIG. 1

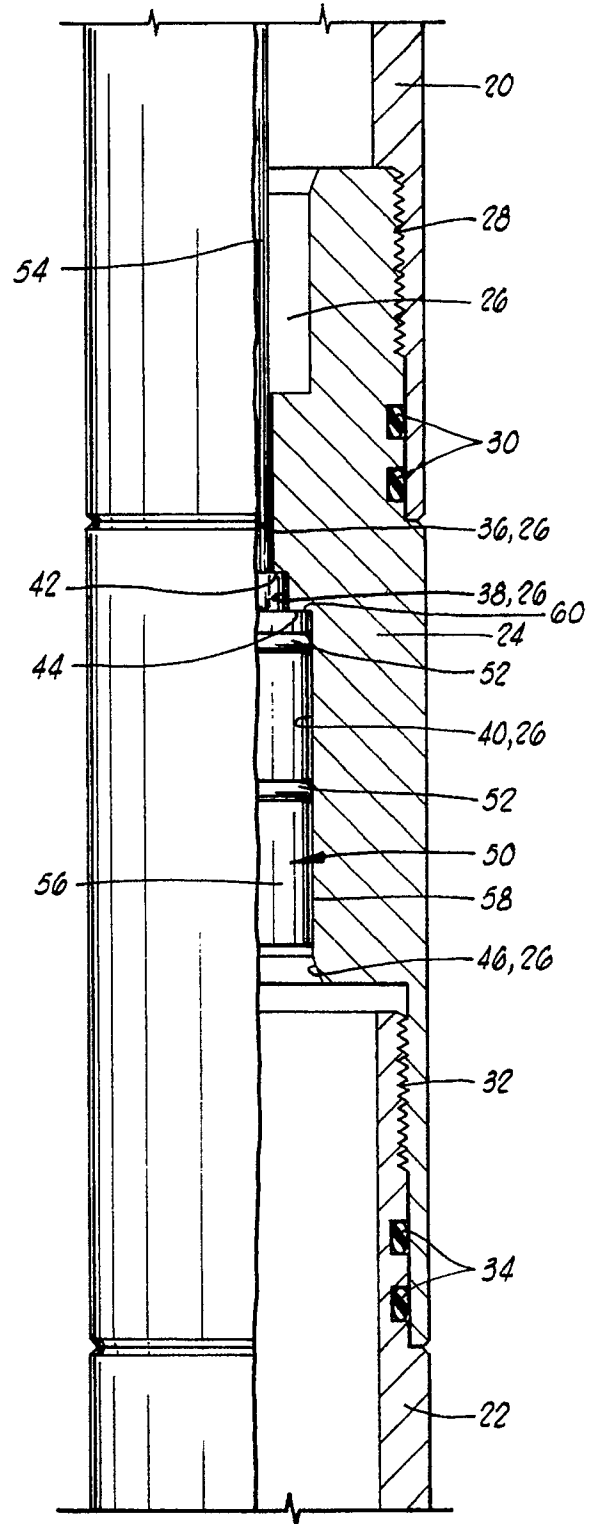

FIG. 2

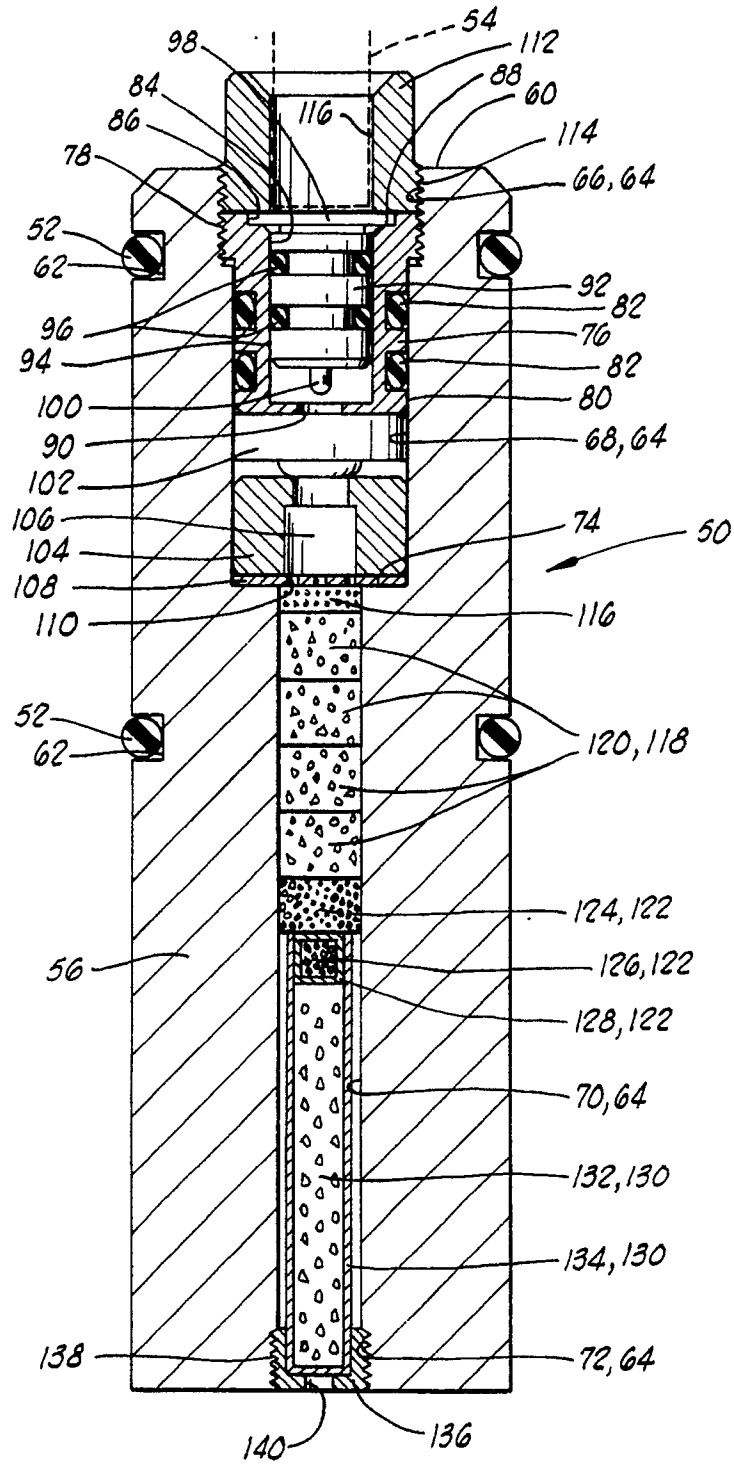

FIG. 3