

E. W. BUELL.
MECHANICAL FEED DEVICE.

(Application filed Nov. 7, 1896.)

(No Model.)

2 Sheets—Sheet 2.

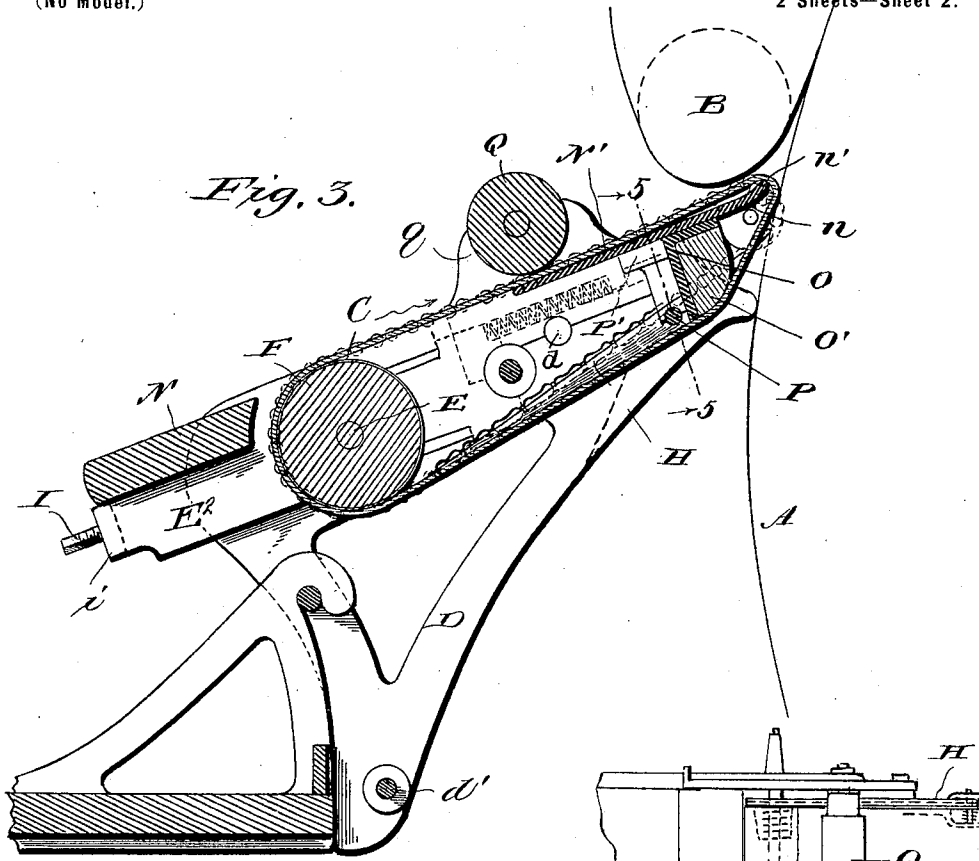

Fig. 3.

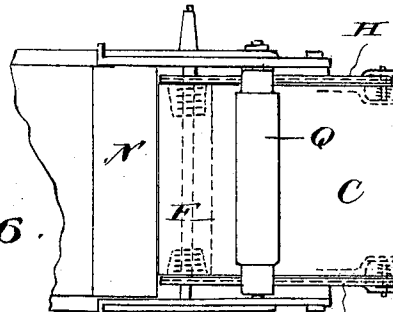

Fig. 6.

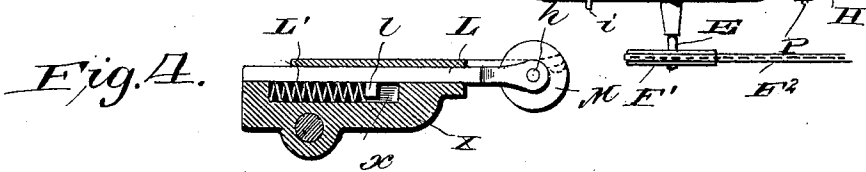

Fig. 4.

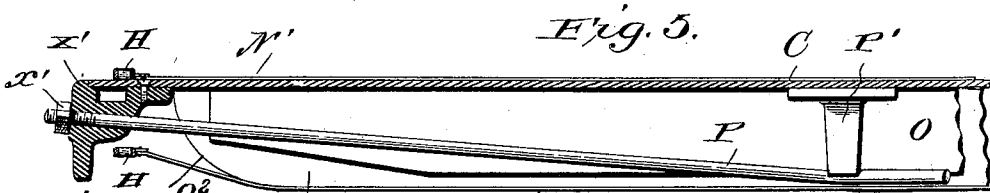

Fig. 5.

Witnesses: O'

L. C. Hoills.
C. A. Bond

Inventor:

Edward W. Buell,
by E. B. Stocking
Atty.

UNITED STATES PATENT OFFICE.

EDWARD W. BUELL, OF CHICAGO, ILLINOIS, ASSIGNOR TO THE TROY LAUNDRY MACHINERY COMPANY, LIMITED, OF SAME PLACE.

MECHANICAL FEED DEVICE.

SPECIFICATION forming part of Letters Patent No. 607,212, dated July 12, 1898.

Application filed November 7, 1896. Serial No. 611,414. (No model.)

To all whom it may concern:

Be it known that I, EDWARD W. BUELL, a citizen of the United States, residing at Chicago, in the county of Cook, State of Illinois, have invented certain new and useful Improvements in Mechanical Feed Devices, of which the following is a specification, reference being had therein to the accompanying drawings.

This invention relates to mechanical feeding devices which may be employed for feeding material usually in sheet form and without regard to lateral or longitudinal dimensions or the number of plies. In fact, the invention may be employed with or applied to all of that character of machinery which operates upon materials in sheet form, of which class of machinery may be mentioned ironing-machines, printing-machines, folding-machines, and in fact any machinery which treats or operates upon material that is preferably or necessarily fed in successive pieces. There may be many instances in which such material is not, strictly speaking, in sheet form, so that the invention or any use of the same is not limited to this particularly specified form of material.

The construction, mode of operation, results, and advantages of the present invention will be set forth in the following description and the accompanying drawings, which illustrate what appears to me to be a practical illustration of one of the many forms of mechanism which may be employed in a practical application of my invention to the principal elements of machines of the class referred to.

Among the objects of the present invention may be mentioned the following: to automatically adjust the tension on the apron to insure the keeping in position of the said apron under all circumstances and to prevent its running to one side and folding up; to provide for the shrinking and stretching of the apron and to permit it to accommodate itself in accordance with the amount of moisture imparted thereto by or absorbed from the goods being passed over said apron. It has been found from practice that the apron by becoming wet by the moisture from the

goods is liable to get too tight and to run hard, which has a tendency to wear out the apron.

Other objects and advantages of the invention will hereinafter appear in the following description, and the novel features thereof will be particularly pointed out in the appended claims.

Referring to the drawings, Figure 1 illustrates a side elevation of my improved feeding device with a portion of the framework of the machine to which the device is applied and with the roll or drum and heating devices of such machine shown diagrammatically and in end elevation. Fig. 2 is a partial plan of Fig. 1. Fig. 3 is a substantially central vertical longitudinal section. Fig. 4 is a detail, partly in elevation and partly in section, showing the support of the small roller and its tension-spring. Fig. 5 is a vertical cross-section with a portion broken away, the section being taken on the line 5 5 of Fig. 3, looking in the direction of the arrows; and Fig. 6 is a detail plan showing both edges of the feeding-apron.

Like letters of reference indicate like parts throughout the several views.

Referring now to the details of the drawings by letter, A designates a roll which in a mangle may be the clothed roll or cylinder or in paper-working machinery one of the primary feed-rolls.

B designates the coöperating device, which in paper-working machines may be the other feed-roll, as indicated by dotted lines, or in laundry machinery, such as a mangle, it may be the heated roll, or, as indicated by full lines, it may be the steam-pan often used in lieu of a heated roll, but serving substantially the same function in connection with the clothed roll A as does the heated roll, or in either class of machinery these devices may be reversed—*i. e.*, A may represent the impression-cylinder, and B the printing-cylinder, of paper-working machines—and similar modifications may be made in the various classes of machinery to which the invention may be applied.

My invention embodies the use of the well-known feeding apron, band, or belt—that is to say, the apron C may be either a single

piece of material of practically the entire width of the operative portion of the machine to which it is applied, or it may be of two or more pieces of any required width, so long as it is endless or mounted for operation after the manner of apron-feeds as heretofore constructed.

D represents the framework for the parts constituting my present improvement. It is shown as capable of having slight movement upon a pivotal support d , and a brace-rod D' , having provision for longitudinal adjustment, is connected with the rod d' at the lower portion of said frame and to some fixed part D^2 of the frame of the machine to which the improved feed is applied, as seen in Fig. 1.

E is a transverse shaft carrying the driving-roll F, and upon each end thereof is a loose sprocket-wheel G. On one end of the shaft E a driving-sprocket F' is applied, which communicates with any suitable source of power by means of a sprocket-chain F^3 .

II are chains passing over said sprocket-wheels and over smaller sprocket-wheels II' at the opposite end of the bed, and to these chains are connected the side edges of the belt or apron C—for instance, by riveting the apron to projections on the sides of the links, as indicated best in Fig. 5. The ends of the shaft E are mounted in movable bearings E' , adapted to move in suitable guides upon opposite sides of the elongated slot e in the side of the frame D, it being understood that there are two of these frames, one upon each side of the machine, and these bearings are adapted to adjust themselves automatically in accordance with the shrinking and stretching of the apron.

I are screw-threaded rods, one connected with each bearing and passed through a lug or projection i on a plate E^2 , carrying the bearing E' . I' is a spring, one around each of these rods, one end of each spring being seated loosely in a socket in the outer face of the bracket D^x , which forms an abutment for said springs, as indicated in Fig. 1, and the other end bearing against the plate or collar i' , which is rendered adjustable by means of the nut I^2 , as indicated in Figs. 1 and 2, so that the tension of the spring I' may be regulated as circumstances may require. This spring serves normally to automatically adjust the tension on the apron. When the apron gets wet and tightens up, the spring also will draw up, and when the apron gets dry it will automatically return to its normal position.

Each bearing or box E' is formed on or secured to a plate E^2 , which rides against the inner face of the frame D and at its end is provided with a lug or projection i . A bracket D^x is formed on the frame D, bridging the slot e and forming an abutment for the spring I' , the rod I being loosely seated in said bracket. Now it will be seen that when the apron shrinks the spring I' will be compressed, and vice versa.

K is a spring around the shaft E of the roller

F, being located in a socket or depression in the end of the roller, as indicated, and serving to keep the apron from running to one side, the outer end of the spring finding a bearing against the sprocket-wheel G.

The smaller sprocket-wheel II' is carried by a forked piece L, which is mounted for end-wise movement in the portion X of the frame and is provided with a lug l , against which is designed to act a spring L' , confined within a socket or recess x in said portion of the frame, as seen more clearly in Fig. 4, the construction being such that the sprocket-wheel II' is adjustable automatically, so that when the driving-roll is adjusted the chain will always keep a proper tension. On the shaft h , which carries this sprocket-wheel and which is held in the bifurcated end of the fork L, is a collar or plate M, which serves as a guide for and prevents outward movement of the chain and consequent outward lateral movement of the belt or apron. A spring M' , arranged around this shaft, between the inner arm of the fork and the sprocket-wheel, serves, in connection with the sprocket-wheel II' and the larger sprocket-wheel G and spring K, to keep the apron from running off to one side, it being understood that the sprocket G is loose upon the shaft and that the roll F does all of the driving, the belt and chains II being moved by the friction of the belt on said roll.

The springs K and M' are duplicated at each end of the apron C, their purpose being to automatically yield to shrinkage and to take up the slack occurring in the apron in the direction lengthwise of said springs. Provision is therefore made in this feed device to counteract the results produced by and overcome the difficulties of shrinking and stretching of a feed-apron both longitudinally and laterally.

The frame is suitably braced by brace or truss rods, as circumstances may require.

The bed N may be of any approved form of construction and provided at its upper end with an extension N' in the form of a metallic plate, extending the entire width of the machine and over which the apron is designed to run, as indicated in Fig. 3. This plate or extension has its upper end depressed slightly, as seen at n , and the extreme upper edge turned slightly upward, as seen at n' , and rounded, as seen best in Fig. 3, so as to give to the goods a tendency to turn upward instead of dropping down. Beneath this extension, at the upper end, is the plate O, in the form of an angle-iron, in which is held the wooden block O' , the under face of which is rounded and tapered up at the ends O^2 , Fig. 5, so as to allow the chains and edges of the apron to run practically straight, while the apron travels in the transversely-concave condition, as seen in Fig. 3 and by dotted lines in Fig. 1, so as to pass beneath the truss-rod P and adjacent parts, as clearly shown in Fig. 5.

P is a truss-rod disposed in close proximity to the vertical portion of the angle-iron, as

indicated in Fig. 3, and this truss-rod is engaged between its ends in the lower ends of the depending arms or brackets P' beneath the extension N'. The ends of the said truss-rod are extended through the side portions X' of the frame, as seen best in Fig. 5, and receiving a nut x' , so that the same may be adjusted as occasion may require. This truss-rod serves to prevent sagging of the iron plate in the middle. The block O' prevents contact of the apron with the truss-rod. The springs facilitate the necessary deflection of the apron for this purpose.

In some classes of machines working upon certain characters of materials it may be necessary or advisable to employ a surface roller in order to maintain the material in its flat smooth condition upon the apron as it moves in the direction of the arrow in Fig. 3, carrying said material to the machine designed to operate thereupon, and I have shown such a roller Q, which may be mounted in suitable bearings above and to rotate upon the apron, as indicated, in this instance the bearings being shown in the lugs or vertical portions q , extending upward from the sides of the frame. This roller may be removably supported in its bearings q' , so as to be removed when not desired for use, and is shown as capable of automatic adjustment, so as to permit of the passage of articles having buttons or other protuberances thereupon without injury to the goods or to the machine. The boxes q' readily move up and down in the bearings q , so that by the action of gravity the roll adjusts itself, as above described.

In practice the feed device may be applied to the machine in proper position in any desired manner. In this instance it is shown as held to the frame R of such machine in such manner as to be adjustable thereupon as circumstances may require, the side portions R' having elongated slots r , through which pass the set-screws S, which provide for the necessary adjustment, and further adjustment is provided for, when necessary, by the adjustable bolts T and T', as seen in Figs. 1 and 2; but other means of adjustment of the feed device to the machine to which it is to be applied may be provided. This adjusting mechanism is duplicated at the opposite side of the machine. It is essential, especially in very wide feed mechanism, to secure perfect parallelism between the feed-apron and the receiving members of a machine and to provide for elevating and depressing the front end of the feed. These adjustments are in practice necessarily fine—that is, extending for extremely-limited distances—as slight variations produce defective operation. By means of the set-screws S the distance of the front of the feed from the receiving members may be approximately determined, and then by means of the bolts T, threaded in lugs R² of brackets R' and abutting against the frame R, the feed-bed and frame D may be slightly oscillated on its trunnions d to de-

termine said distance with exactness. The elevation and depression of the feed-bed may subsequently be accomplished by the sole adjustment of the bolts T', Fig. 1, which project through a boss T³ on the bracket R' against the trunnions of the frame, which are mounted in a slot T⁴, one wall T⁵ of which is pivotally connected, as at T⁶, and the other secured removably, as by a bolt T⁷, to the main body of said bracket.

Operators of machinery intended for treating textile fabrics, paper, cloth, leather, sheet metal, or plastics and familiar with the peculiar characteristics of each of these materials can readily adjust these mechanical feed devices to the necessities of the case. By the means of the adjustment provided the tension of the apron is controllable independently of the amount of its surface contact with the roll, and the mechanical feed may be thoroughly tempered to any peculiarities existing in the material to be operated upon. The automatic adjustment and action of the parts tend to greatly facilitate the work, lessen the necessity of attention on the part of the operator, and insure the apron running more evenly and of more regular tension, and it will be kept much drier than aprons under similar circumstances in devices as previously constructed.

Modifications in detail may be resorted to without departing from the spirit of the invention or sacrificing any of its advantages.

Having thus described my invention, what I claim as new, and desire to secure by Letters Patent, is—

1. The combination with a roll and an endless apron and its moving and guiding mechanisms, of means yielding transversely of the apron for automatically adjusting the lateral tension of said apron; substantially as described.

2. The combination with a roll and an endless apron and its moving mechanism, of means yielding transversely of the apron for the automatic change of position of the edge of the apron in accordance with the lateral shrinking and stretching thereof; substantially as described.

3. The combination with an apron-supporting bed having a stiffening bar or truss thereunder and an endless apron, of chains to which the edges of the apron are attached, means for moving said chains, and means for deflecting the apron out of the plane occupied by said bar or truss and the plane traversed by said chains; substantially as described.

4. The combination with an apron-supporting bed and an endless apron, of chains to which the edges of the apron are attached, means for moving said chains, means for deflecting the apron out of the plane traversed by said chains, and springs to permit a lateral movement of said apron, substantially as described.

5. The combination with a receiving element of a machine, of feed mechanism com-

prising an endless apron, a framework for supporting said apron and its driving mechanism, said framework being mounted adjustably to and from and independently of said receiving element, and means yielding transversely of the apron for automatically adjusting the lateral tension of said apron, substantially as described.

6. The combination with a receiving element of a machine, of feed mechanism comprising an endless apron, a framework for supporting said apron and its driving mechanism, said framework being mounted adjustably to and from and independently of said receiving element, means yielding transversely of the apron for automatically adjusting the lateral tension of said apron, and means for adjusting the longitudinal tension of said apron, substantially as described.

7. The combination with a feed-apron, of sprocket-chains secured to the edges thereof, means for causing the apron to travel, sprockets cooperating with the chains, and a yielding device cooperating with the sprockets and arranged and operating to retain the apron in a smooth condition, substantially as described.

8. The combination with a feed-apron, of sprocket-chains secured to the edges thereof, means for causing the apron to travel, sprockets loosely mounted upon the shaft of the driving-roll and cooperating with said chains, and a yielding device operating with the sprockets to exert a lateral tension on said apron, substantially as described.

9. The combination with an endless apron, of the chains to which the edges of said apron are connected, the sprockets over which said chains pass, and a driving-roll on the shaft of which both of said sprockets are loosely mounted; substantially as described.

10. The combination with an endless apron, of the chains to which the edges of said apron are connected, the sprockets over which said chains pass, a driving-roll on the shaft of which both of said sprockets are loosely mounted, and springs around the ends of said shaft acting upon the sprockets; substantially as described.

11. The combination with the roller and its shaft mounted in spring-held bearings, of an endless apron having chains, sprockets loose on said shaft, springs around the shaft bearing against the sprockets, and spring-held arms carrying the companion sprockets; substantially as described.

12. The combination with the roller and its shaft mounted in spring-held bearings, of an endless apron having chains, sprockets loose on said shaft, springs around the shaft bearing against the sprockets, spring-held arms carrying the companion sprockets, and means

for deflecting the apron out of the plane of the chains; substantially as described.

13. The combination with the frame having a socket, of a forked piece mounted to move endwise in guides in said socket, a spring located in said socket to project said forked piece, a journaling shaft in said forked piece, a sprocket-wheel loosely mounted upon said journaling shaft, and a spring interposed between said sprocket and an arm of said forked piece, substantially as described.

14. The combination with the frame having sockets, of the forked pieces at opposite sides of the frame mounted to move endwise in guides therein, and having lugs disposed in said sockets, sprockets carried by the shafts mounted in said arms, springs located in the sockets and bearing on the lugs, collars on said shafts and springs around said shafts bearing against the inner faces of the sprockets; substantially as described.

15. The combination with the side frames and the truss-rod connecting the same, of the bed and its extension, an endless apron having chains, slidingly-mounted sprockets for said chains and a block disposed beneath said extension and having rounded under face to deflect the apron out of the plane traversed by its moving chains; substantially as described.

16. The combination with the side frames and the truss-rod connecting the same, of the bed and its extension, an endless apron having chains, a block disposed beneath said extension and having rounded under face to deflect the apron out of the plane traversed by its moving chains, and an angle-plate disposed beneath the extension and in which said block is located; substantially as described.

17. The combination with a receiving-roll of a machine, of an endless apron having its supporting mechanism mounted independent of that of the receiving-roll and adapted to support the apron with relation to the said roll, and means yielding transversely and longitudinally of the apron for automatically adjusting the tension of the apron in all directions; substantially as specified.

18. The combination with an endless apron and its supporting-bed, of means yielding transversely of the apron for automatically controlling the tension on the apron and for automatically conforming to lateral changes of such apron during its travel; substantially as described.

In testimony whereof I affix my signature in presence of two witnesses.

EDWARD W. BUELL.

Witnesses:

ALLAN CONKLING,
J. W. GRIFFEN.