



US 20150135507A1

(19) **United States**

(12) **Patent Application Publication**
Army

(10) **Pub. No.: US 2015/0135507 A1**

(43) **Pub. Date: May 21, 2015**

(54) **PROTECTIVE LEAKAGE SHIELD FOR LIQUID TO AIR HEAT EXCHANGER**

Publication Classification

(71) Applicant: **Hamilton Sundstrand Corporation**, Windsor Locks, CT (US)

(51) **Int. Cl.**
F28F 11/00 (2006.01)

(72) Inventor: **Steven D. Army**, Enfield, CT (US)

(52) **U.S. Cl.**
CPC **F28F 11/00** (2013.01)

(21) Appl. No.: **14/606,163**

(57) **ABSTRACT**

(22) Filed: **Jan. 27, 2015**

A leakage shield for an air to liquid heat exchanger includes a drain pan, a liquid header panel, and a closure bar. The drain pan has a first side and a second side opposite the first side. The liquid header panel has a lower end attached to the first side of the drain pan, and extends vertically upwards from the first side of the drain pan. The closure bar panel has a lower end attached to the second side of the drain pan, and extends vertically upwards from the second side of the drain pan.

Related U.S. Application Data

(62) Division of application No. 13/236,979, filed on Sep. 20, 2011.

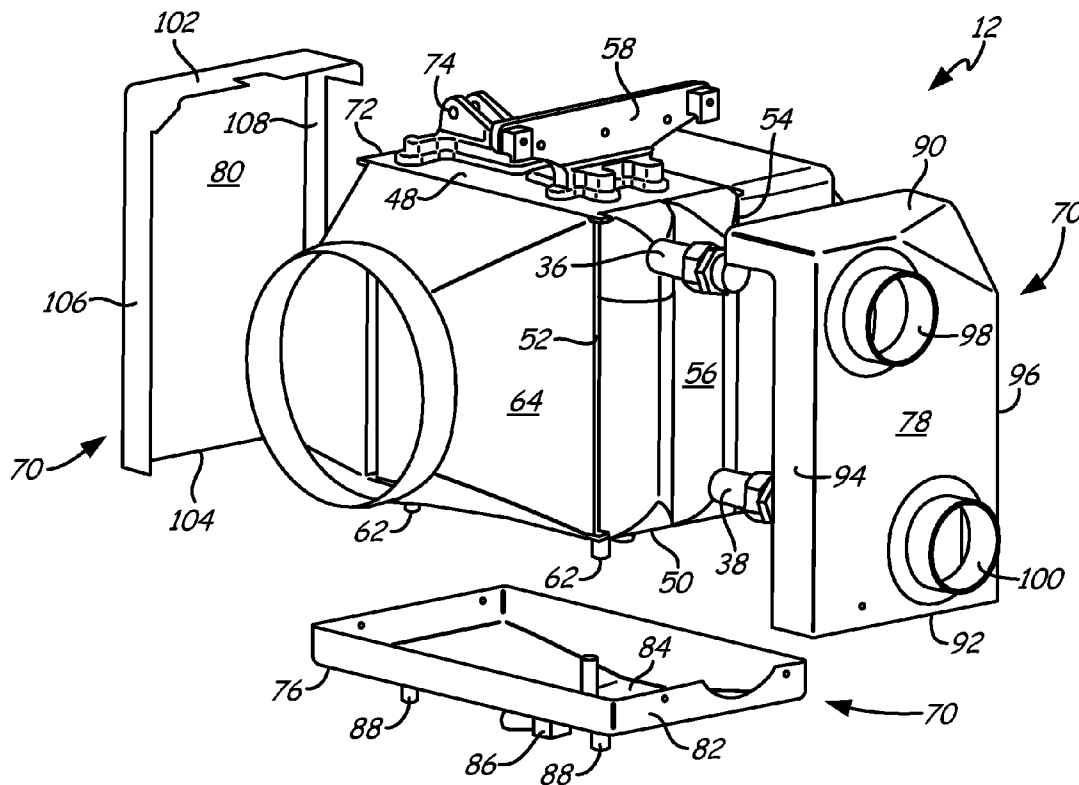

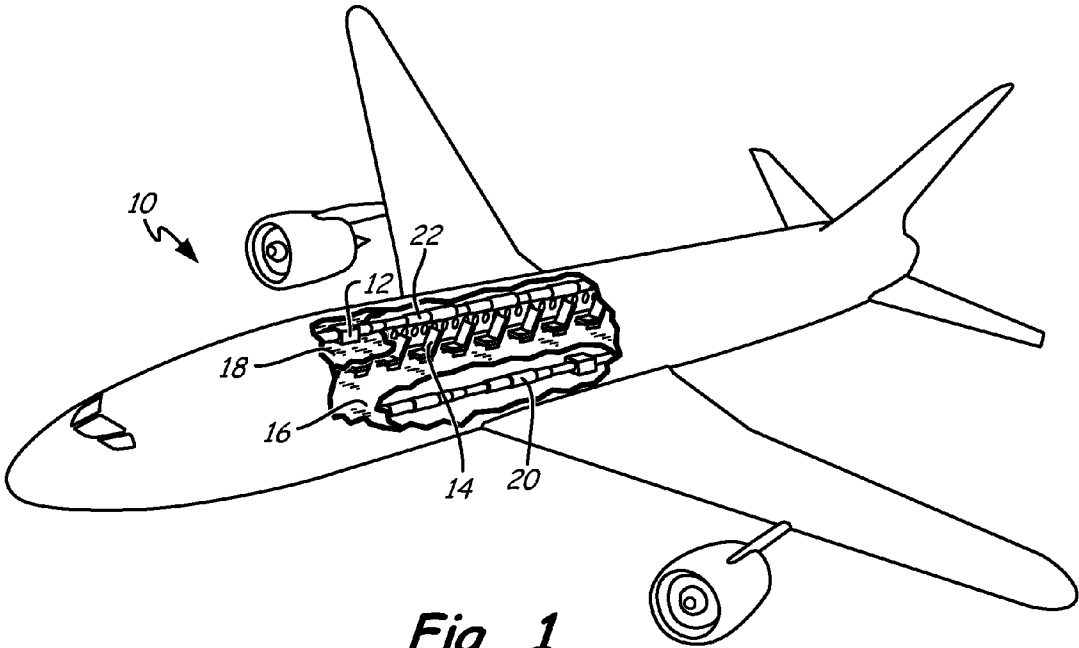

Fig. 1

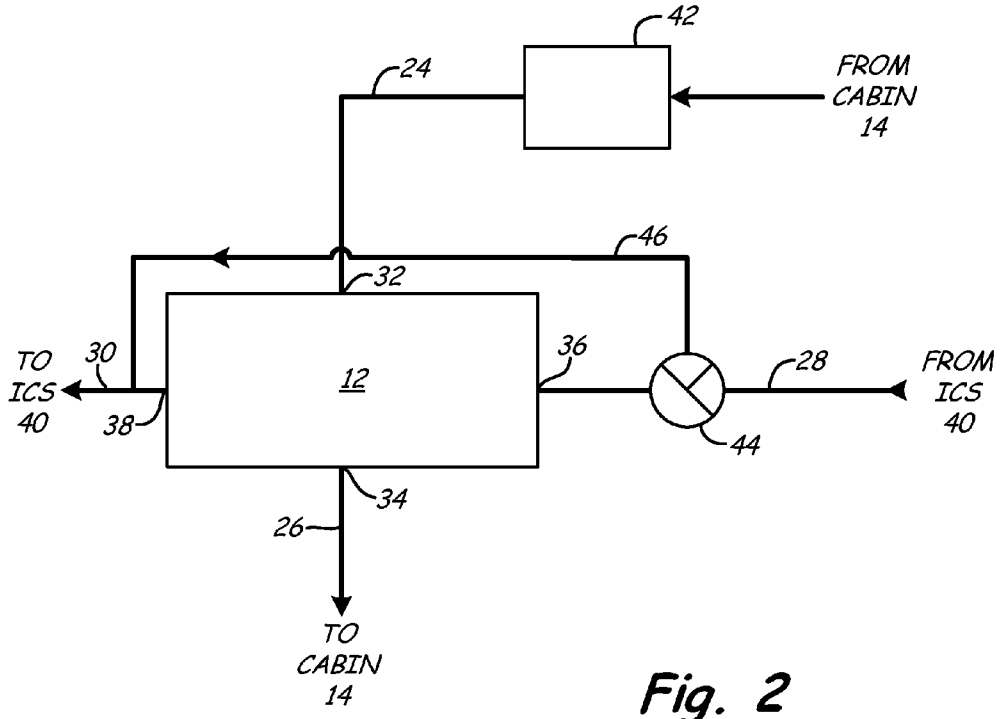

Fig. 2

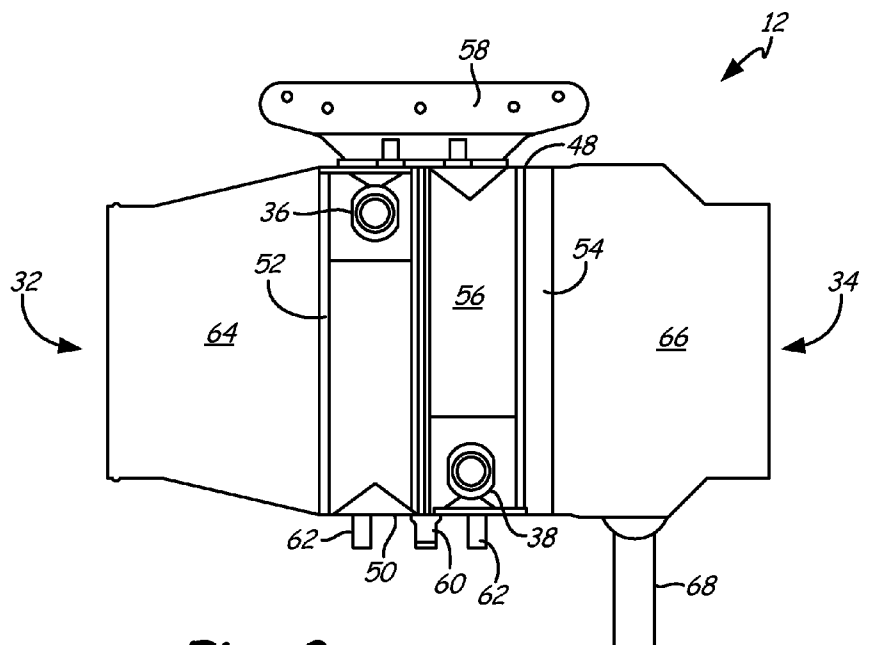

Fig. 3

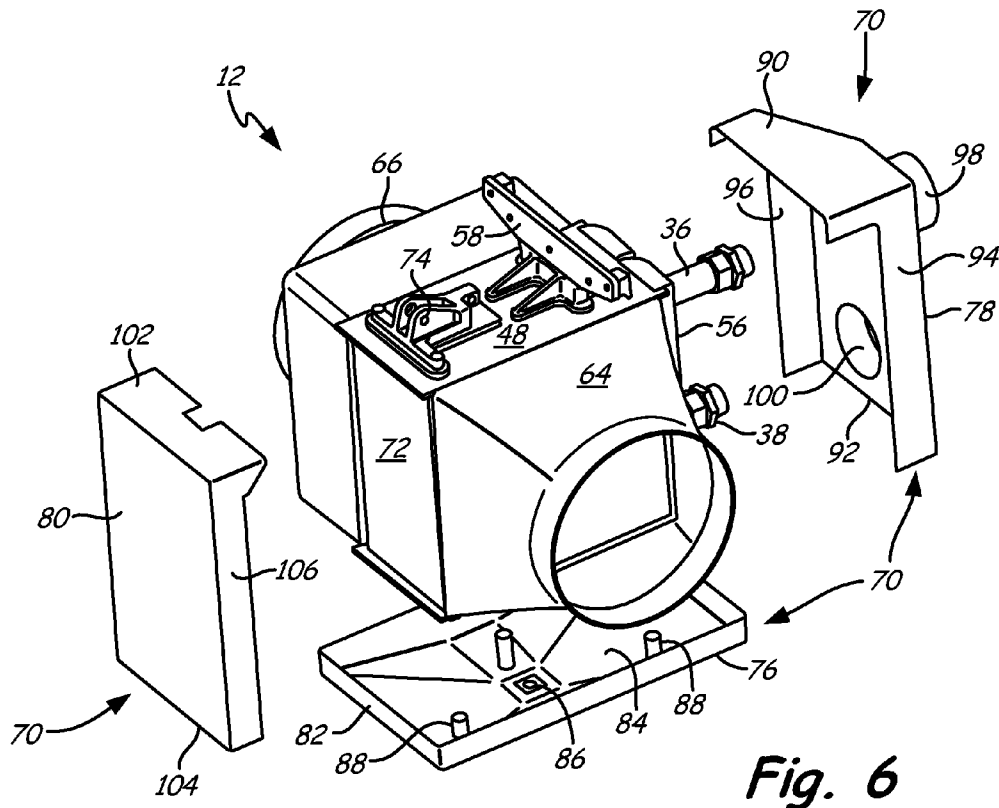

Fig. 6

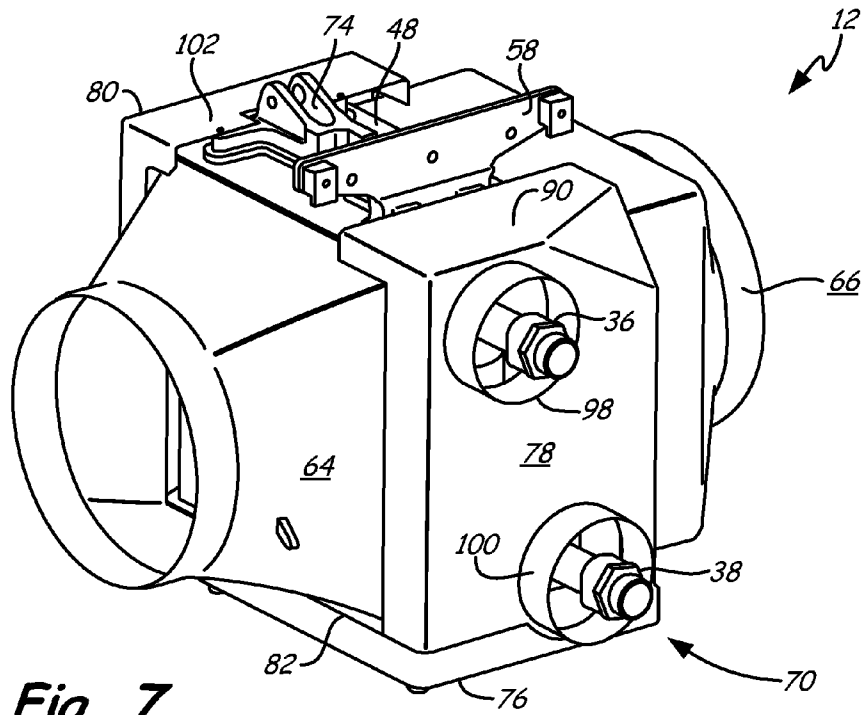

Fig. 7

PROTECTIVE LEAKAGE SHIELD FOR LIQUID TO AIR HEAT EXCHANGER

CROSS-REFERENCE TO RELATED APPLICATION(S)

[0001] This divisional application claims priority from application Ser. No. 13/236,979, filed Sep. 20, 2011, entitled PROTECTIVE LEAKAGE SHIELD FOR LIQUID TO AIR HEAT EXCHANGER, which is hereby incorporated by reference.

BACKGROUND

[0002] The present disclosure relates generally to heat exchangers and more specifically, to leakage shields for liquid to air heat exchangers.

[0003] Airplane cabins require a constant flow of conditioned air. It is common to equip an airplane with an environmental control system for providing conditioned air to the cabin and other pressurized regions. Known environmental control systems can be further subdivided into an air cycle system responsible for obtaining fresh exterior air and an air recirculation system responsible for obtaining used cabin air. The air cycle system and air recirculation system commonly overlap at an air mixer where a portion of fresh exterior air is mixed with a portion of used cabin air to produce a mixed airstream for distribution to the cabin.

[0004] Environmental control systems usually include heat exchangers for cooling air prior to entry into the cabin. Both air-to-air heat exchangers and liquid-to-air heat exchangers are frequently operated in environmental control systems. Most commonly, heat exchangers are placed within an air conditioning pack of the air cycle system for cooling fresh exterior air prior to mixing with recirculation air and introduction into the cabin.

SUMMARY

[0005] A heat exchanger includes an air inlet, an air outlet, a liquid inlet, a liquid outlet, a drain pan, a liquid header panel, and a closure bar panel. The air inlet is located on a first side and the air outlet is located on a second side opposite the first side. The liquid inlet and the liquid outlet are located on a third side, where the third side extends between the first side and the second side. The drain pan covers a bottom, the liquid header panel covers the third side, and the closure bar panel covers a fourth side opposite the third side, where the fourth side extends between the first side and the second side. The drain pan, liquid header panel, and closure bar panel form a shield preventing liquid leakage from the heat exchanger.

[0006] A leakage shield for an air to liquid heat exchanger includes a drain pan, a liquid header panel, and a closure bar. The drain pan has a first side and a second side opposite the first side. The liquid header panel has an upper end attached to a first mounting bracket, a lower end attached to the first side of the drain pan, and a central portion extending vertically upwards from the first side of the drain pan. The closure bar panel has an upper end attached to a second mounting bracket, a lower end attached to the second side of the drain pan, and a central portion extending vertically upwards from the second side of the drain pan.

[0007] A method of installing a leakage shield on a liquid to air heat exchanger includes covering a bottom of the heat exchanger with a drain pan. The method further includes

covering a first side of the heat exchanger with a liquid header panel and covering a second side of the heat exchanger with a closure bar panel.

BRIEF DESCRIPTION OF THE DRAWINGS

[0008] FIG. 1 is a cut-away view of an airplane having a heat exchanger in accordance with the present disclosure.

[0009] FIG. 2 is a schematic representation of fluid flow to and from the heat exchanger of FIG. 1.

[0010] FIG. 3 is a side view of the heat exchanger of FIGS. 1 and 2.

[0011] FIG. 4 is a front perspective view of the heat exchanger of FIG. 3 with a leakage shield exploded therefrom.

[0012] FIG. 5 is a bottom perspective view of the heat exchanger and exploded leakage shield of FIG. 4.

[0013] FIG. 6 is a top perspective view of the heat exchanger and exploded leakage shield of FIGS. 4 and 5.

[0014] FIG. 7 is a front perspective view of the heat exchanger with leakage shield assembled of FIGS. 4-6.

DETAILED DESCRIPTION

[0015] As used herein, the term “airplane” includes any type of aircraft having a cabin and recirculation system. FIG. 1 is a cut-away view of airplane 10 having heat exchanger 12 in accordance with the present disclosure. Airplane 10 includes passenger cabin 14 having floor 16 and ceiling 18. Located below floor 16 is lower ducting 20, and located above ceiling 18 is upper ducting 22, which is attached to heat exchanger 12. Air from cabin 14 is drawn into upper ducting 22 above ceiling 18 for cooling by heat exchanger 12 before being returned to cabin 14.

[0016] As shown in FIG. 1, airplane 10 is a commercial jetliner having cabin 14 for transporting passengers. Cabin 14 is defined at a bottom by floor 16 and at a top by ceiling 18. Heat exchanger 12 is attached to upper ducting 22 and is located in the area above ceiling 18, otherwise known as the “crown” of airplane 10. A first portion of used cabin air is drawn from a bottom of cabin 14 through floor 16 and into lower ducting 20. This first portion of used cabin air is ducted through lower ducting 20 to an unpressurized region of airplane 10 for mixing with fresh, conditioned air in an air mixer. A second portion of used cabin air is drawn from a top of cabin 14 through ceiling 18 and into upper ducting 22. This second portion of used cabin air is sent through upper ducting 22 and to heat exchanger 12 in the crown of the airplane, which is a pressurized region of airplane 10 like cabin 14. Heat exchanger 12 cools this second portion of relatively warm, used cabin air such that it becomes relatively cool, conditioned recirculation air. This recirculation air is then ducted from heat exchanger 12 through distribution ducting and directly back into cabin 14 for re-use by passengers.

[0017] FIG. 2 is a schematic representation of fluid flow to and from heat exchanger 12. Depicted in FIG. 2 are heat exchanger 12, cabin 14, warm air 24, cool air 26, cool liquid 28, warm liquid 30, air inlet 32, air outlet 34, liquid inlet 36, liquid outlet 38, integrated cooling system (ICS) 40, fan 42, diverter valve 44, and liquid bypass 46. Cool liquid 28 cools warm air 24 within heat exchanger 12 thereby producing cool air 26 and warm liquid 30.

[0018] Heat exchanger 12 is a liquid to air heat exchanger located in the pressurized crown region of airplane 10 for locally cooling cabin air, such as the second portion of used

cabin air discussed with reference to FIG. 1. Warm air 24 is ducted from cabin 14 to heat exchanger 12. Warm air 24 is cooled within heat exchanger 12 to become cool air 26. Cool air 26 is sent from heat exchanger 12 through distribution ducting and back to cabin 14 as a recirculation airstream. Cool liquid 28 is piped from integrated cooling system (ICS) 40 to heat exchanger 12. In the depicted embodiment, the liquid is propylene glycol-water (PGW) that has been chilled by a vapor cycle and used to cool the galley cooling units before being sent to heat exchanger 12 as cool liquid 28. Within heat exchanger 12, warm air 24 rejects heat into cool liquid 28, which becomes warm liquid 30. Warm liquid 30 exits heat exchanger 12 and is piped back into ICS 40. In the embodiment depicted, warm liquid 30 is sent from heat exchanger 12 to a condenser associated with the air cycle system in an unpressurized region of the airplane.

[0019] Warm air 24 enters heat exchanger 12 at air inlet 32, and cool air 26 exits heat exchanger 12 at air outlet 34. Cool liquid 28 enters heat exchanger 12 at liquid inlet 36, and warm liquid 30 exits heat exchanger 12 at liquid outlet 38. Fan 42 is located between cabin 14 and heat exchanger 12 to pull warm air 24 from cabin 14 into heat exchanger 12. Diverter valve 44 is located between ICS 40 and heat exchanger 12 to divert a portion of cool liquid 28 from ICS 40 around heat exchanger 12 through liquid bypass 46. For example, when cooling demand for heat exchanger 12 is lower, an increased portion of cool liquid 28 is sent through liquid bypass 46 around heat exchanger 12. The specific architecture of heat exchanger 12 is discussed below with reference to FIG. 3.

[0020] FIG. 3 is a side view of heat exchanger 12 from FIGS. 1 and 2. Depicted in FIG. 3 are heat exchanger 12, air inlet 32, air outlet 34, liquid inlet 36, liquid outlet 38, top 48, bottom 50, first side 52, second side 54, third side 56, 3-way mount 58, liquid drain 60, bosses 62, air inlet header 64, air outlet header 66, and condensation drain 68. Heat exchanger 12 is configured to reject heat from air to liquid, thereby locally cooling air for recirculation and reuse.

[0021] As described above with respect to FIG. 2, heat exchanger 12 includes air inlet 32, air outlet 34, liquid inlet 36, and liquid outlet 38. Heat exchanger 12 is defined by top 48, bottom 50, and four sides, three of which are visible in FIG. 3: first side 52, second side 54, and third side 56. Top 48 includes 3-way mount 58 for securing heat exchanger 12 into the crown of airplane 10. Bottom 50 is located opposite of top 52. Liquid drain 60 and bosses 62 extend vertically downwards from bottom 50. Liquid drain 60 can be attached to tubing to direct excess liquid away from heat exchanger 12 and bosses 62 are welded to an end sheet of heat exchanger 12 to mount a drain pan (described below with reference to FIGS. 4-7). First side 52 of heat exchanger 12 is attached to air inlet header 64 which defines air inlet 32 for receiving warm air 24 from cabin 14. Second side 54 of heat exchanger 12 is located opposite first side 52. Second side 52 is attached to air outlet header 66 which defines air outlet 34 for directing cool air 26 from heat exchanger 12 back to distribution ducting, and eventually cabin 14. Condensation drain 68 extends vertically downwards from a bottom of air outlet header 66 for directing condensed water away from the air stream. Like liquid drain 60, condensation drain 68 can be attached to tubing that directs excess water away from heat exchanger 12.

[0022] FIGS. 4-6 are perspective views of heat exchanger 12 from FIG. 3 with leakage shield 70 exploded therefrom. FIG. 7 is a perspective view of heat exchanger 12 with heat shield 70 fully assembled. Depicted throughout FIGS. 4-7 are

the components of heat exchanger 12: liquid inlet 36, liquid outlet 38, top 48, bottom 50, first side 52, second side 54, third side 56, 3-way mount 58, bosses 62, air inlet header 64, air outlet header 66, fourth side 72, and 1-way mount 74. Also shown throughout FIGS. 4-7 are the components of leakage shield 70: drain pan 76, liquid header panel 78, and closure bar panel 80. Drain pan 76 includes lip 82, depression 84, drain hole 86, and bosses 88. Liquid header panel 78 includes top 90, bottom 92, first side 94, second side 96, inlet opening 98, and outlet opening 100. Closure bar panel 80 includes top 102, bottom 104, first side 106, and second side 108. Drain pan 76, liquid header panel 78, and closure bar panel 80 are secured around heat exchanger 12 to form leakage shield 70.

[0023] The structure of heat exchanger 12 is described above with reference to FIG. 3. The discussion of FIGS. 4-7 will focus on the structure of leakage shield 70 and its attachment to heat exchanger 12. Leakage shield 70 includes drain pan 76 for covering bottom 50 of heat exchanger 12, liquid header panel 78 for covering third side 56 of heat exchanger 12, and closure bar panel 80 for covering fourth side 72 of heat exchanger 12. Leakage shield 70 can be formed from metal or plastic. When assembled as shown in FIG. 7, leakage shield 70 prevents liquid from escaping heat exchanger 12. When heat exchanger 12 is installed in aircraft 10, leakage shield 70 will protect the crown, as well as cabin 14, from fluid leakage and any water condensation created on exterior surfaces of heat exchanger 12.

[0024] Drain pan 76 includes lip 82, depression 84, drain hole 86, and bosses 88. Lip 82 extends upwardly from each of the four sides of drain pan 76 to form an upstanding rectangle. Depression 84 is located centrally within a center of drain pan 76. Drain hole 86 is located centrally within depression 84 and can be attached to tubing for directing any liquid collected within drain pan 76 away from heat exchanger 12. Bosses 88 extend through a bottom surface of drain pan 76 are aligned with bosses 62 extending from bottom 50 of heat exchanger 12. Bolts can be inserted through bosses 88 of drain pan and into bosses 62 of heat exchanger 12 to secure drain pan 76 to bottom 50 of heat exchanger 12. Once attached, drain pan 76 prevents fluid leakage from bottom 50 of heat exchanger 12.

[0025] Liquid header panel 78 includes top 90, bottom 92, first side 94, second side 96, inlet opening 98, and outlet opening 100. Liquid header panel 78 is substantially rectangular in shape and is configured to cover third side 56 of heat exchanger 12. Top 90 extends at an approximately right angle from an upper end of liquid header panel 78 to attach to 3-way mount 58 on top 48 of heat exchanger 12. Bottom 92 of liquid header panel 78 is open and configured to rest within lip 82 on a first side of drain pan 76. First side 94 and second side 96 of liquid header panel 78 extend at approximately right angles to contain third side 56 of heat exchanger 12 from air inlet header 64 to air outlet header 66. Liquid header panel 78 includes inlet opening 98 and outlet opening 100, which are circular and configured to surround liquid inlet 36 and liquid outlet 38, respectively. Both inlet opening 98 and outlet opening 100 include raised lips for cooperating with tubing that conduct liquid to and from heat exchanger 12. Once attached, liquid header panel 78 prevents fluid leakage from third side 56 of heat exchanger 12.

[0026] Closure bar panel 80 includes top 102, bottom 104, first side 106, and second side 108. Closure bar panel 80 is substantially rectangular in shape and is configured to cover and protect fourth side 72 of heat exchanger 12. Fourth side

72 of heat exchanger 12 is considered the “closure bar face” and is used to close off the air and/or liquid circuit. Top 102 extends at an approximately right angle from an upper end of closure bar panel 80 to attach to 1-way mount 74 on top 48 of heat exchanger 12. Bottom 104 of closure bar panel 80 is open and configured to rest within lip 82 on a second side of drain pan 76. First side 106 and second side 108 of closure bar panel 80 extend at approximately right angles to contain fourth side 72 of heat exchanger 12 from air inlet header 64 to air outlet header 66. Once attached, closure bar panel 80 prevents fluid leakage from fourth side 72 of heat exchanger 12.

[0027] As shown in FIG. 7, when leakage shield 70 is assembled it surrounds heat exchanger 12. Top 90 of liquid header panel 78 extends outwardly from its attachment to 3-way mount 58 at top 48 of heat exchanger 12. Liquid header panel 78 extends downwardly from top 90 to cover third side 56 of heat exchanger such that bottom 92 of liquid header panel 78 rests within lip 82 of drain pan 76. Bolts attach bottom 92 of liquid header panel 78 to the first side drain pan 76. Similarly, top 102 of closure bar panel 80 extends outwardly from its attachment to 1-way mount 74 at top 48 of heat exchanger 12. Closure bar panel 80 extends downwardly from top 102 to cover fourth side 72 of heat exchanger such that bottom 102 of closure bar panel 80 rests within lip 82 of drain pan 76. Bolts attach bottom 104 of closure bar panel 80 to the second side of drain pan 76. Insulation can be provided between heat exchanger 12 and leakage shield 70 to prevent air from coming in contact with heat exchanger 12. Leakage shield 70 substantially surrounds, and therefore prevents any liquid leakage from, heat exchanger 12.

[0028] Although the present invention has been described with reference to preferred embodiments, workers skilled in

the art will recognize that changes may be made in form and detail without departing from the spirit and scope of the invention.

1. A method of installing a leakage shield on a liquid to air heat exchanger, the method comprising:
 - covering a bottom of the heat exchanger with a drain pan;
 - covering a first side of the heat exchanger with a liquid header panel; and
 - covering a second side of the heat exchanger with a closure bar panel.
2. The method of claim 1, further comprising:
 - attaching the drain pan to the bottom of the heat exchanger;
 - attaching the liquid header panel to the drain pan and a top of the heat exchanger;
 - attaching the closure bar panel to the drain pan and the top of the heat exchanger.
3. The method of claim 2, further comprising:
 - welding at least one boss to the bottom of the heat exchanger.
4. The method of claim 3, wherein attaching the drain pan to the bottom of the heat exchanger includes bolting the drain pan to the at least one boss.
5. The method of claim 2, wherein attaching the liquid header panel to the top of the heat exchanger includes bolting the liquid header panel to a mount located on the top of the heat exchanger.
6. The method of claim 2, wherein attaching the closure bar panel to the top of the heat exchanger includes bolting the closure bar panel to a mount located on the top of the heat exchanger.
7. The method of claim 1, further comprising:
 - surrounding a liquid inlet and a liquid outlet with the liquid header panel.

* * * * *