

(19)
(12)

(KR)
(A)

(51) 。 Int. Cl.⁷
H04N 5/57

(11)
(43)

10-2004-0040699
2004 05 13

(21) 10-2002-0068898
(22) 2002 11 07

(71) 416

(72) 5 504 902

4 208-62 4 2

1 176 25 308

3 301 1204

(74)

:

(54)

가 , 가 (PDF) ,
(CDF) 가 ,
가 , 가 , 가

4

(histogram), PDF, CDF

1a 1b , 1c 1d 1a 1b ,
 2 ,
 3 2 ,
 4 ,
 5 4 ,
 6a, 6b ,
 7 5 ,
 8 .
 * *

100 : 200 :
 300 : 400 :
 500 :

(histogram equalization)

(contrast)

(contrast ratio)

가

가

1a 1b , 1c 1d 1a 1b ,
 1a 1c 가 ,
 1a , 가 , 1b 가
 가 1d 1c , 가 , 가 1b , 가
 가
 2 .

(PDF:Probability Density Function)(10),
 (CDF:Cumulative Distribution Function)(20), (Mapping)(30)

(PDF)(10) (input image) 가
 (PDF) (PDF)
 (CDF)(20) (PDF) (cumulative distribution)
 (CDF) [1]

$$CDF = \sum_{i=0}^n PDF(i)$$

, i = 0, 1, 2, 3

(30) [1] (CDF) (input image) 가
 , 가 가

3a 3h 2

3a 가 , 3a 가 [1]
 (PDF) 3b 가
 (CDF) 3c가 , 3c (CDF) 256
 3d , 3d 가 100 (input image)
 (30) 80

, 3e , (A) (B) 가 (C)
 가 (PDF) 3f . 3f 가
 3g (CDF) 256 [1] (CDF) 3g
 , 3d 100 (PDF) 120 (PDF) 3f 3h가 , (PDF)
 (A) 가 (C) 가
 , (B), (C) 가 , 가 (A)

가 , 가 (PDF)
 (CDF) 가

가 , 가 1
 1 , 1 , 1 2 1 2 2 2
 , 2 , 2

1, 1, 가, 1, 1, 1, 1
 1, 2, 가, 2, 2, 2, 2, 2
 2, 1, 2, 2, 2, 2, 2

$$CDF(K) = CDF(K) - \frac{CDF(N)}{N \times K} + K$$

(CDF)

(CDF)

$$CDF(K) = CDF(K) - \frac{CDF(N)}{N \times K} + K$$

er threshold)(200), (PDF)(100), (BUBO:Bit Under threshold Bit Ov
 Mapping)(500) (CDF)(300), (CDF compansation)(400), (

(PDF) (PDF)(100) (input image) (PDF) [1]
 (BUBO)(200) (over threshold) 1 (PDF)(100)
 (under threshold) 2, 2, 2, 256
 1 (0 255) (input image) 1 2, 20,
 200 20 (15) 20 (CDF)(300)
 210) 200 ((CDF)(300) 가

(CDF)(300) (CDF) (BUBO)(200) [2] (PDF)

(400) (CDF)(300)

5 4 (BUBO)(200)

(BUBO)(200) 1 (210) 2 (220) 1 (210)

(PDF)(100) 1 가 2 (220) 1

1 2 (220) 2 가 2 (CDF)(300)

0) (211) 1 (210) , 1 (211), 1 (212), 1 (213) 1 (212)

(211) 1 (PDF)(100) 1 (212) '가' (211) 1 (213)가

가 가 2 (220) 가 1 (211) 1 2

(220) 1 (21)

2 (220) 2 (221), 2 (222), 2 (223) 2 (221)

2 , 2 (222) 가 2 (222) 1 (210)

가 2 (222)

가 1 (210) (CDF)(300) 2 (222)

(CDF)(300)

6a 6b 5 1 (210) 2 (220)

6a 5 1 (210) , 6a (1) (input image) (PD

F) , 6a (2) 1 , 6a (3) 1

6b 5 2 (220) , 6b (1) (PDF) , 6b

(2) 2 , 6b (3) 2 2

6a 6b 가

7 5 (CDF compansation)(400)

(440), 가 (450) (CDF compansation)(400) (410), (420), (430),

(410) (input image) 가 가 (420)

(410) (420) (('255')

(430) (430) (420)

(440) (CDF)(300) (430) 가 (CDF)(3

00) (430)

가 (450) (410) (440)

, 7 (CDF compansation)(400)

, (X) 가 가 .

X=[1,1,2,2,2,2,3,3,3,3,4,4,4,4,4,4,4,4,4,4,4,4,3,3,3,3,2,2,2,2,1,1,]

, '1' , '4' . 4가
 , 256(0 255) .

PDF) , (X) (PDF)(100) 가 , (

PDF[1] = 4

PDF[2] = 8

PDF[3] = 8

PDF[4] = 13

, '1' 4 , '2' , 8 , '3' 8
 , '4' 13 .

, (PDF)가 (CDF)(200) 가 (CDF)

CDF[1] = 4

CDF[2] = 12

CDF[3] = 20

CDF[4] = 33

, CDF[2] PDF[1] + PDF[2] , CDF[4] PDF[1] + PDF[2] + PDF[3] + PDF[4] .

2] (CDF compansation)(400) (CDF) [

$$CDF(K) = CDF(K) - \frac{CDF(N)}{N \times K} + K$$

, N 1 4 , 가 , '4'가 , K

[2] (CDF) .

CDF[1] = (4 - 33/(4 × 1)) + 1 = - 3.25

CDF[2] = (12 - 33/(4 × 2)) + 2 = - 2.50

CDF[3] = (20 - 33/(4 × 3)) + 3 = - 1.75

$$CDF[4] = (33 - 33/(4 \times 4)) + 4 = + 4.00$$

Up Table (-3.25, -2.50, -1.75) '1' 가 (CDF, LUT:Look

$$LUT[1] = 1$$

$$LUT[2] = 1$$

$$LUT[3] = 1$$

$$LUT[4] = 4$$

(CDF) (Mapping)(500) 가 1, 2, 3 가
'1' 가 '4' '4' '4' (contrast ratio)

[2] , 가 (430) 'N' '255'가

8

(S100). (PDF)(100) 가 (PDF) (PDF)
('0' '255'), 10% 10% 가
(S200). 가 가 (PDF)
가 가 (CDF) (S400). (CDF) (PDF)
(S500). 가 (LUT) (LUT)

가 가 가

가 가 가

(57)
1. 가 (PDF) ;

가 , 가 ;
 ; (CDF) ;

1 **2.** ,
 ,
 가 1 ;
 가 2 ;

2 **3.** ,
 ,
 , 1 1 ; 1 , 1
 2 , 2 2 ; ,

3 **4.** ,
 1 ,
 가 , 1 1 ;
 1 1 ;
 1 1 ; 1 , 1 1

4 **5.** ,
 2 ,
 가 , 2 2 ;
 2 2 ;
 1 2 ; 2 2 2

5 **6.** ,
 ,

; :

$$CDF(K) = CDF(K) - \frac{CDF(N)}{N \times K} + K$$

, N , 가 , K K .

7.

;

;

(CDF)

;

8.

7

,

,

;

;

;

9.

8

,

,

(CDF)

;

;

10.

9

,

,

;

;

11.

10

,

,

,

:

;

$$CDF(K) = CDF(K) - \frac{CDF(N)}{N \times K} + K$$

, N , 가 , K K .

1a

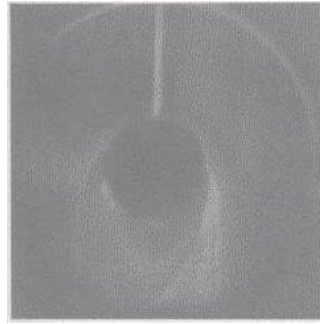

1b

화소의 갯수

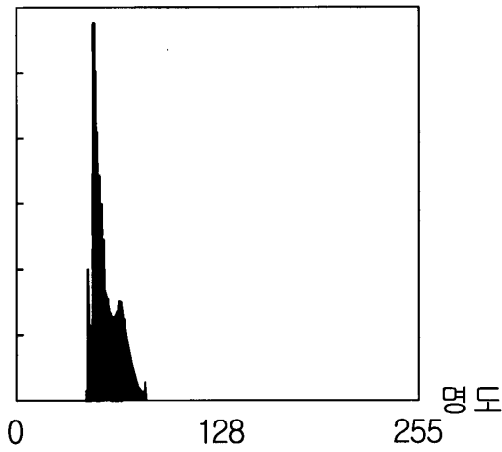

1c

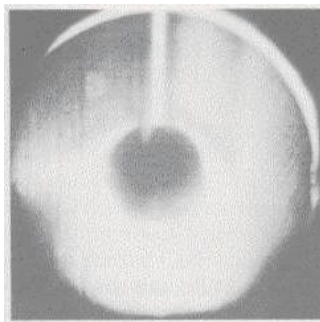

1d

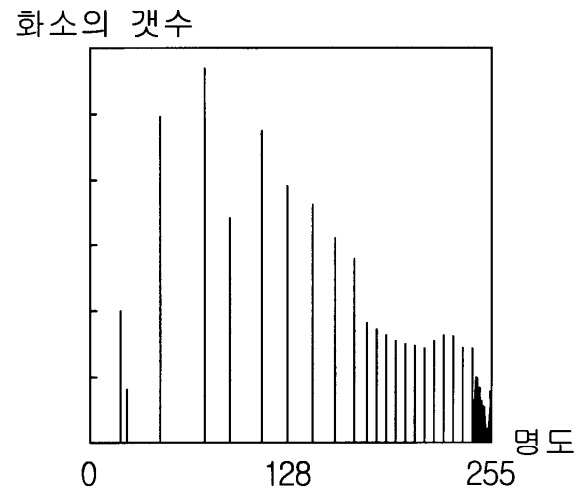

2

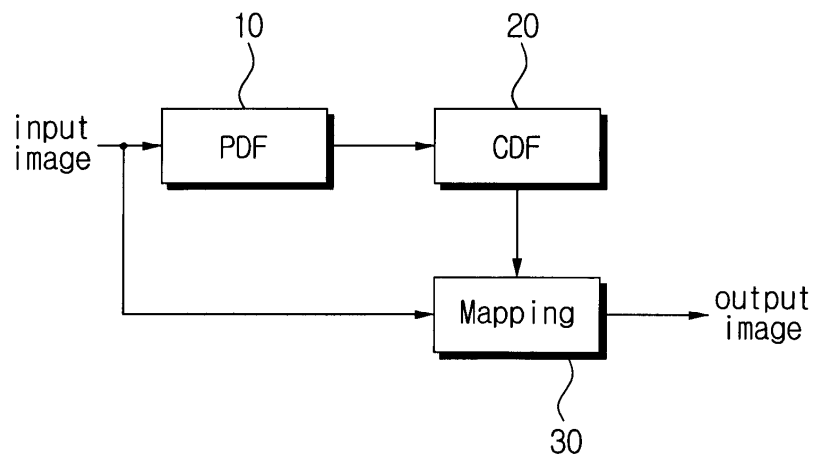

3a

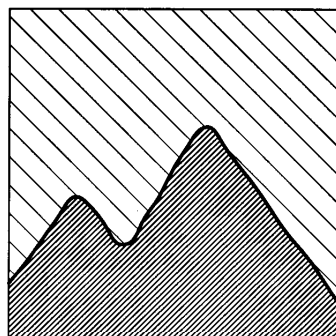

3b

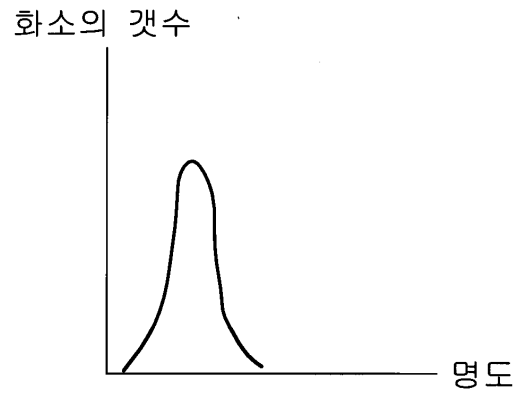

3c

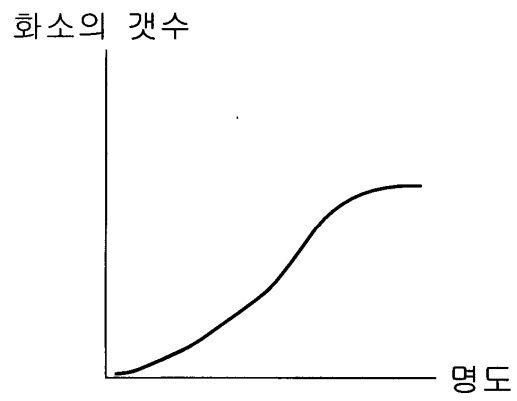

3d

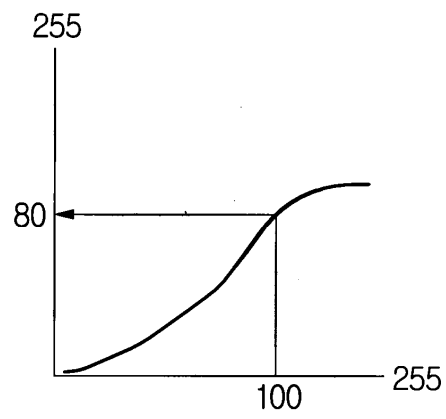

3e

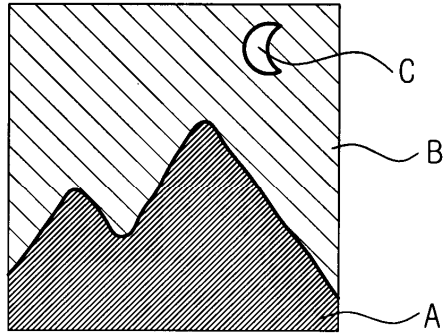

3f

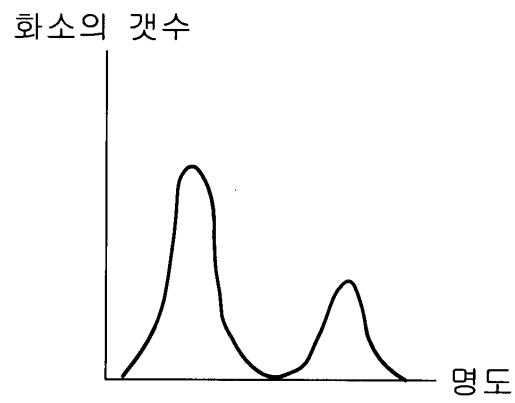

3g

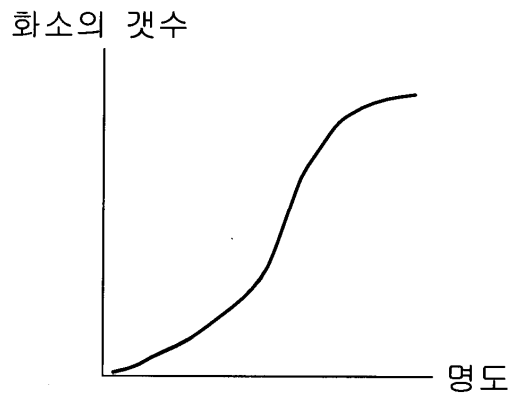

3h

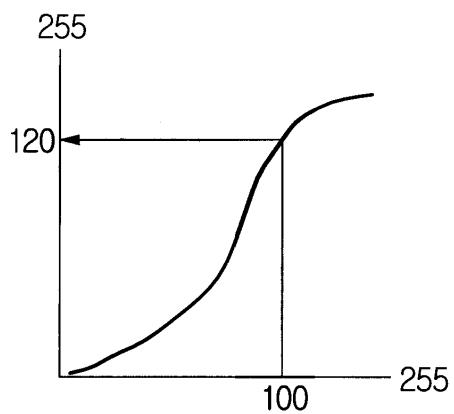

4

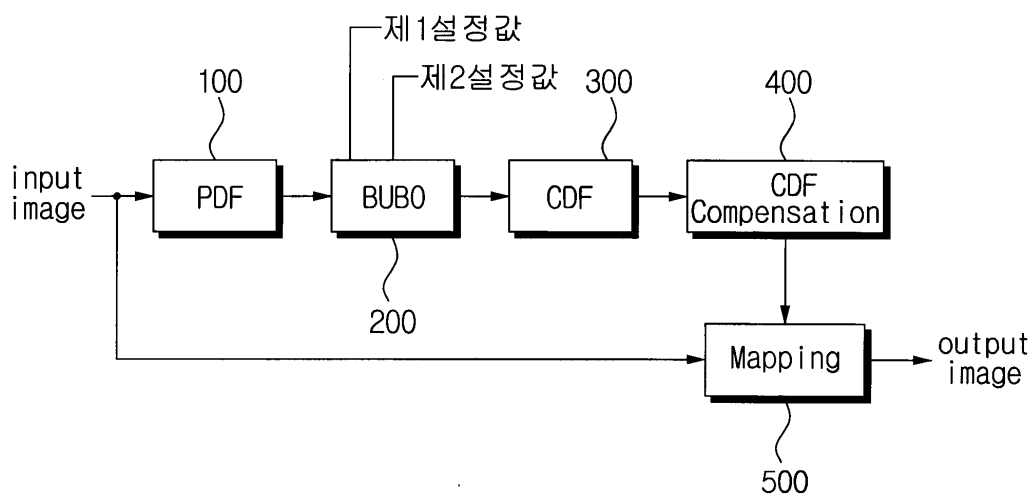

5

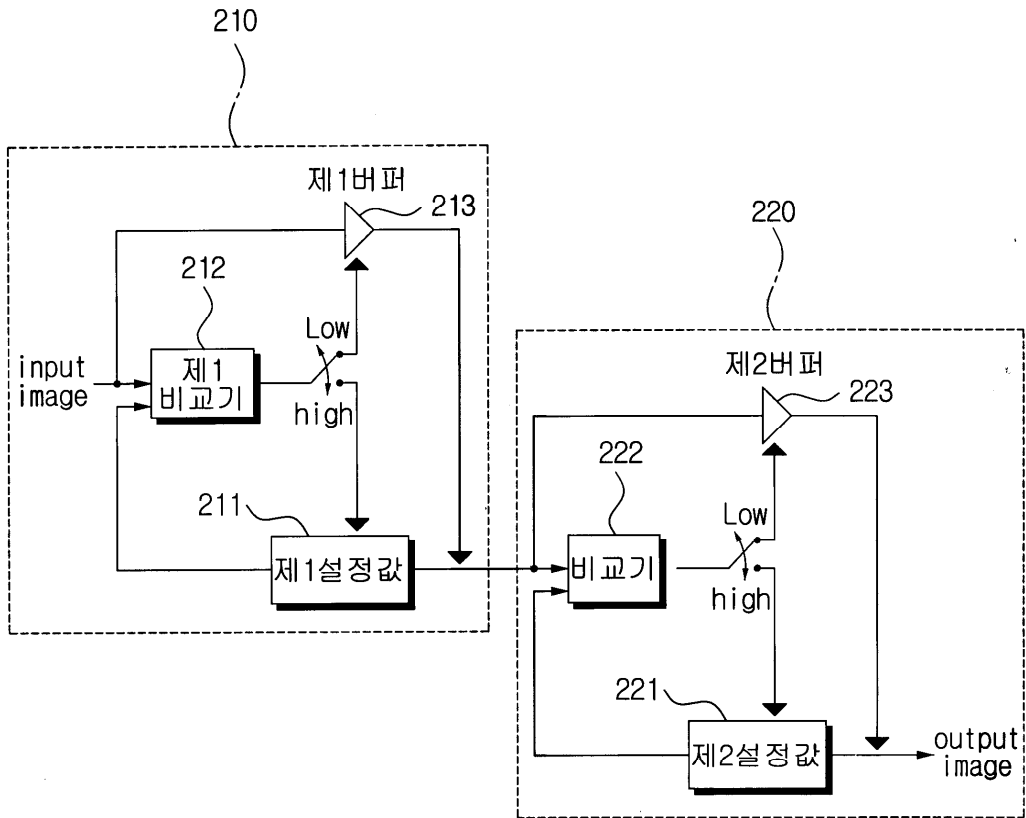

6a

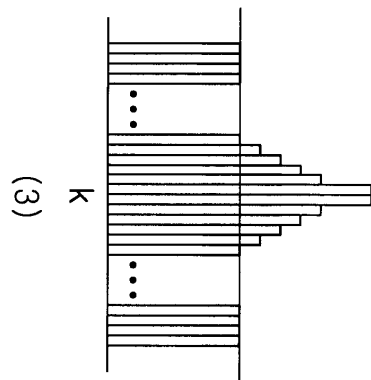
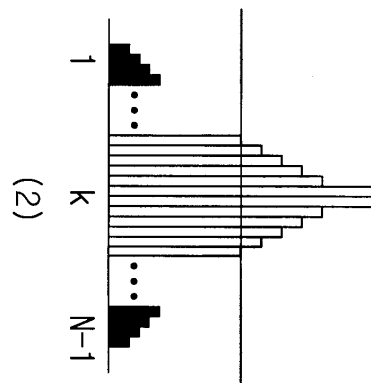
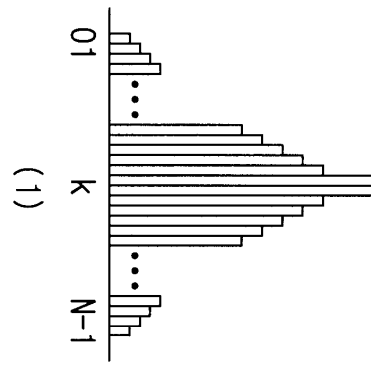

6b

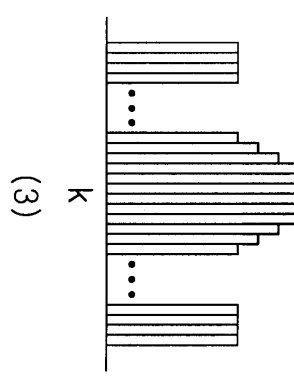
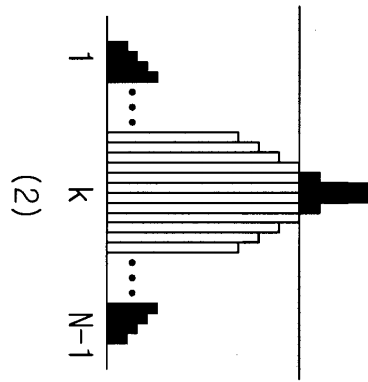
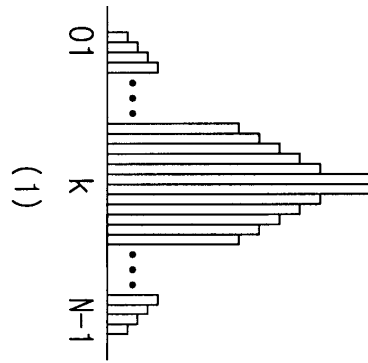

7

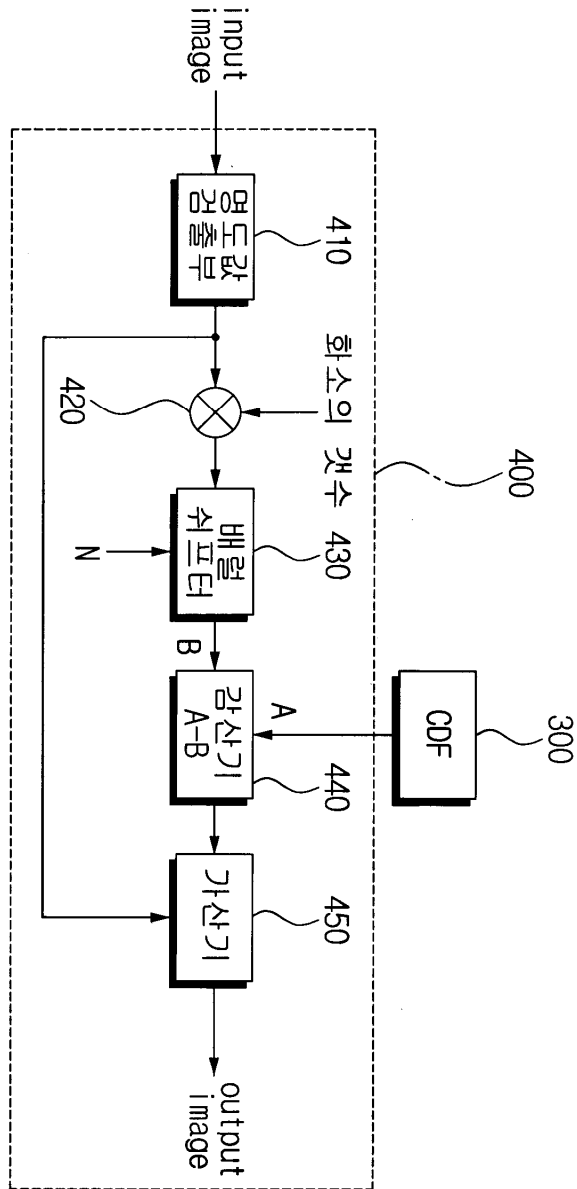

8

