

Oct. 6, 1936.

P. A. JOHNSON

2,056,524

COMBINATION BUSHING FOR BEER BARRELS

Filed Aug. 16, 1934

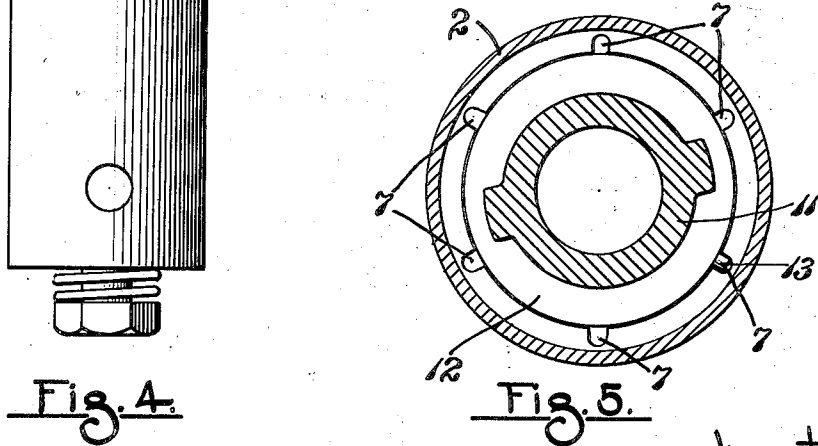
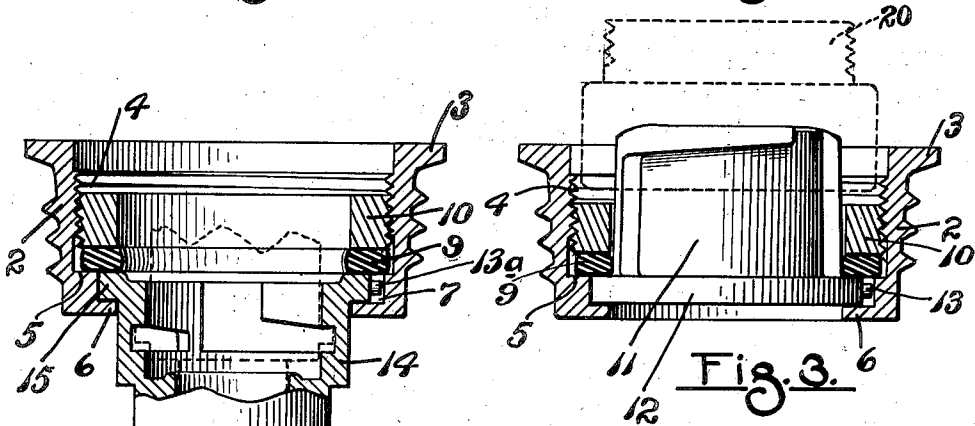
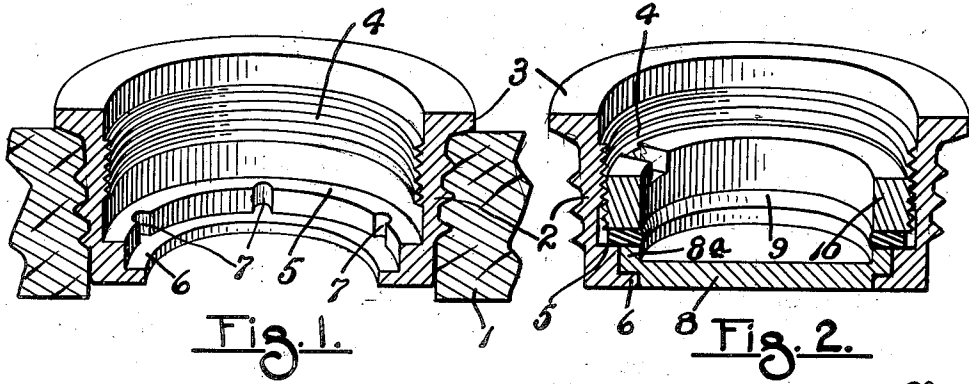
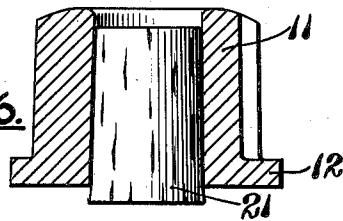

Fig. 4.

Fig. 5.

Fig. 6.



Inventor
Paul A. Johnson
By Liverance and Van Antwerp
Attorneys

UNITED STATES PATENT OFFICE

2,056,524

COMBINATION BUSHING FOR
BEER BARRELS

Paul A. Johnson, Grand Haven, Mich.

Application August 16, 1934, Serial No. 740,076

9 Claims. (Cl. 217-113)

This invention relates to a universal bushing for beer barrels.

Barrels which are to contain beer have bung holes through which the barrel is filled. The beer is pumped or otherwise tapped from the barrel. It is common to provide at the bung hole of the barrel a bushing of metal. Many and different types of bushings are used with which are associated plugs and/or valves for sealing the barrel against escape of the beer and with which a tapping mechanism may be used to withdraw the beer from the barrel.

There are several systems of tapping the beer from the barrel with each of which special plugs or valves for the different systems are used and heretofore it has been necessary, with a particular type of bushing used, to use with it a particular valve or plug designed to fit the bushing or be used therewith or integrally connected thereto. With my invention I provide a universal bushing capable of being sealed against escape of the beer and with which any of the different regular makes of plugs or valves may be used.

When the beer is shipped from the brewery the barrels equipped with the bushing of my invention may be shipped to any part of the country with an assurance that when received the tapping and withdrawal of the beer from the barrel can be readily attained. Or in many cases the barrels leaving the brewery may be equipped with a particular plug or valve largely used in a certain section of the country so that the tapping system there can be operated, while in another section of the country a different plug used with the tapping system used in such section of the country may be applied to the bushing. With my invention the standard and regular makes of plugs or valves may be used with the universal bushing which I have invented.

The construction of the bushing and the way that it may be used may be understood from the following description, taken in connection with the accompanying drawing, in which

Fig. 1 is a perspective and central vertical section through the bushing of my invention showing the same applied at the bung hole of a barrel.

Fig. 2 is a similar section through the bushing illustrating the same sealed against escape of the beer.

Fig. 3 is a vertical section showing the bushing unsealed and with one type of plug therein.

Fig. 4 is a similar section showing the bushing with another type of plug and sealing valve mounted therein, and

Fig. 5 is a horizontal section through the lower portion of the bushing, looking downwardly.

Fig. 6 is a sectional side view of the plug.

Like reference characters refer to like parts in the different figures of the drawing.

The bung hole of the barrel 1 receives the bushing which preferably is of brass and has vertical walls 2 equipped with threads at its outer side to screw into the bung hole in the case of wooden barrels. With steel barrels the bushing is brazed or otherwise permanently secured in place. The bushing at its upper end is equipped with an outwardly extending annular flange 3 to come against the outer side of the barrel around the bung hole. It is interiorly threaded between its upper and lower ends at 4. Adjacent its lower end it is provided with a horizontal annular ledge 5 extending inwardly below which is an inwardly extending annular lip 6. The horizontal ledge 5 extends entirely around the inner side of the bushing and at the vertical surface between said ledge and the upper side of the lip 6 a plurality of spaced apart grooves or recesses 7 are made. Six of such grooves or recesses 7 are shown but the number may be varied and be greater than six in number.

The bushing of my invention when secured at the bung hole of a barrel permits the filling of the barrel with beer. It may be sealed by inserting a circular sealing disk 8 which, at its peripheral portions, is formed with an upwardly extending annular ring 8a below which is an annular recess which receives the lip 6, the ring 8a being of sufficient height that its upper side lies in the same plane with the ledge 5. A ring gasket 9 is placed on the ledge and upper side of the part 8a and a locking ring 10 exteriorly threaded is screwed downwardly into the bushing at its inner side where interiorly threaded at 4. This makes a complete seal preventing any loss of the beer through leakage.

The one to whom the barrel of beer is delivered may be supplied with tapping equipment including the necessary plug. In such case the ring 10 is removed and a plug such as the plug 11 placed in the bushing upon the ledge 6. Previously, in some forms of combined bushings and plugs, the bushing and a plug like the plug 11 are made integral. In the present case the plug 11 at its lower end has an annular outwardly extending ring 12 which bears upon the lip 6 with the upper side of the ring 12 in the same plane with the ledge 5. In such case the gasket ring 9 is placed against the upper sides of ledge 5 and ring 12 and the plug is held in place by rescrewing the lock-

ing ring 10 against the gasket 9. The plug 11 is of the type known as the Peerless type. It is a well known type of tapping plug and as said before has been cast integral with the bushing the same as though the ring 12 and the lower part of the bushing, as shown in Fig. 3, were integrally cast together. With my construction the plug tap is separate and may be releasably secured to the bushing in the same relative position that it has previously occupied when cast integral therewith.

A pin 13 projects laterally from one side of the ring 12 and may be received in any selected recess 7 of the several recesses which are present.

In Fig. 4 the bushing is used to receive a so-called Golden Gate type valve indicated at 14, having at its upper end an annular lip 15 which bears against the lip 6 and is held in sealed position by the ring gasket 9 and the locking ring 10 threaded into the bushing. Such construction includes a valve which is closed during shipment but which may be opened for tapping out the beer. It likewise has a pin 13a extending from the annular member which may be seated in any selected groove 7.

The slots or grooves 7 and the single pin 13 or 13a are desirable for use particularly when the bushings are screwed into place in wooden barrels. It is necessary, particularly with the regular Golden Gate type of valve construction used that there be a proper and correct location of the Golden Gate type valve on the bushing, otherwise the system used for withdrawing the beer from the barrel will be interfered with. Where the bushings are fitted into metal barrels they can be permanently welded or fastened in their correct predetermined position but in wooden barrels the final circumferential position is more or less a happenstance one and consequently I provide the plurality of slots or grooves 7.

It is also to be noted, see Fig. 6, that the plug 11 tapers outwardly whereby there is no possibility of inadvertent or accidental removal of the cork 21 and this is very essential inasmuch as if the cork 21 accidentally came out all of the beer would be lost. Furthermore, since the plug 11 is bodily detachable from the bushing located therearound, the cork may be inserted therewith while the plug 11 is separate and detached from its bushing and this provides for a secure connection because the cork 21 can be inserted from the inner side of the plug. Also, the plug 11 may be positioned upon a support or anvil of extremely solid construction whereby the cork may be driven home in an efficient and decisive manner, thus precluding any accidental removal thereof.

With my invention of universal bushing the same can be used with a special plug such as described with reference to Fig. 3 to fit any standard type system similar to the well known Peerless type system. The bushing can also be used by inserting a regular beer valve or what is commonly known as the Golden Gate valve. The slots or grooves 7 in the bushing, shown as six in number may be increased so as to give a larger number of positions of adjustment if it is necessary. There will be great savings to the smaller breweries which will need only to equip barrels with the universal bushings of my invention to which may be applied the device for whichever type of tapping system may be used. The detachable sealed connection of a plug, such as the plug 11, or a valve such as the valve structure indicated at 14 is very quickly, easily and simply attained and the removal thereof is quite as readily

obtained. The invention while of a simple character is very practical and useful and has so proved in service.

The invention is defined in the appended claims and is to be considered comprehensive of all forms of structure coming within their scope.

I claim:

1. A metal bushing for beer barrels comprising, a member of sleeve-like form open at both ends and, adjacent one end, being provided with an annular inwardly extending ledge and with an annular inwardly extending lip projecting farther inwardly than said ledge, said ledge and said lip being spaced apart with an annular cylindrical surface between the lip and ledge, said ledge and said cylindrical surface having a plurality of spaced apart recesses therein extending toward said lip, the depth of these recesses being less than the width of the said annular ledge whereby a continuous annular surface is had completely around the ledge.

2. In a structure of the class described, a bushing of sleeve-like form adapted to be located in the side of a barrel, said bushing being interiorly threaded between its upper and lower ends, and having thickened walls a short distance above its lower end providing a horizontal ledge, an inner cylindrical surface extending downwardly from the inner edges of said ledge and a horizontal annular lip extending inwardly at the lower end of the cylindrical surface, a member seated upon said lip having a flange the upper side of which is in the same plane with the horizontal ledge, a gasket covering the joint between said ledge and flange, and a clamping ring threaded into the sleeve bearing upon said gasket.

3. A construction containing the elements in combination defined in claim 2, said ledge at a plurality of spaced apart points around the same having downwardly extending recesses therein and a pin projecting outwardly from the flange on said member entering one of said recesses, and adapted to be located in a selected recess.

4. A fitting consisting of a bushing having vertical walls of predetermined exterior surfaces for attachment in the bung hole of the barrel, an inwardly extending lip rigidly attached to the bushing, a plug having an opening therethrough, an outwardly extending ring rigidly attached to the plug and seating upon the lip in any chosen one of several circumferential positions, sealing means detachably engageable with the bushing and bearing against the ring to hold it in fluid tight relationship therewith, and means for preventing rotative movement between the bushing and the plug.

5. A combination of elements as set forth in claim 4 in which the opening through the plug is slightly tapered.

6. A combination of elements as set forth in claim 4 in which the plug is reversible.

7. In combination, a bushing adapted to be fastened in the bung hole of a barrel, a plug having a tapered opening therethrough, said plug fitting within the bushing with either end of the opening positioned inwardly as desired and means for detachably securing the plug in its chosen position in the bushing.

8. In a device of the class described, a bushing having vertical walls with internal threads thereon spaced from one end thereof, an inwardly extending ledge and lip construction at the other end, a member having a cylindrical portion snugly interlocking with the ledge and lip construction and a threaded ring threadedly en-

gaged with the internal threads in the bushing, the walls above the internal threads being of such shape as to maintain the threaded ring in alignment with the axis of the internal threads
5 prior to their engagement whereby ease of entry is attained.

9. In a device of the class described, a bushing having vertical walls with internal threads thereon, an inwardly extending ledge and lip construction below the threads, a member having a
10

cylindrical portion snugly engaged against the ledge and resting upon the lip construction, the top of the member adjacent the ledge being in the same plane as the ledge, a washer resting upon the ledge and the portion of the member adjacent thereto and threaded means engaging said threads and contacting the washer to push the same downwardly against both the ledge and the adjacent portion of the said member.

PAUL A. JOHNSON. 10