

(19) World Intellectual Property
Organization
International Bureau



(43) International Publication Date
7 July 2005 (07.07.2005)

PCT

(10) International Publication Number
WO 2005/061400 A1

- (51) International Patent Classification⁷: **C03B 29/04**
- (21) International Application Number:
PCT/IB2004/004069
- (22) International Filing Date:
10 December 2004 (10.12.2004)
- (25) Filing Language: English
- (26) Publication Language: English
- (30) Priority Data:
0328917.0 12 December 2003 (12.12.2003) GB
60/529,746 17 December 2003 (17.12.2003) US
0419839.6 7 September 2004 (07.09.2004) GB
60/610,223 16 September 2004 (16.09.2004) US
- (72) Inventors; and
(75) Inventors/Applicants (for US only): **TWITCHEN, Daniel, James** [GB/GB]; 10 Park Drive, Sunningdale Berkshire SL5 0BD (GB). **SCARSBROOK, Geoffrey, Alan** [GB/GB]; 40 Cavendish Mead, Sunninghill, Ascot Berkshire SL5 9TD (GB). **MARTINEAU, Philip, Maurice** [GB/GB]; Littlewick End, Coronation Road, Littlewick Green Berkshire SL6 3RA (GB). **SPEAR, Paul, Martyn** [GB/GB]; 44 Brompton Drive, Pinkneys Green, Maidenhead, Berkshire SL6 6SP (GB).
- (74) Agents: **DONALD, Heather, June** et al.; Spoor & Fisher, P. O. Box 41312, Craighall, 2146 Morningside (ZA).
- (81) Designated States (unless otherwise indicated, for every kind of national protection available): AE, AG, AL, AM, AT, AU, AZ, BA, BB, BG, BR, BW, BY, BZ, CA, CH, CN, CO, CR, CU, CZ, DE, DK, DM, DZ, EC, EE, EG, ES, FI, GB, GD, GE, GH, GM, HR, HU, ID, IL, IN, IS, JP, KE, KG, KP, KR, KZ, LC, LK, LR, LS, LT, LU, LV, MA, MD, MG, MK, MN, MW, MX, MZ, NA, NI, NO, NZ, OM, PG, PH, PL, PT, RO, RU, SC, SD, SE, SG, SK, SL, SY, TJ, TM, TN, TR, TT, TZ, UA, UG, US, UZ, VC, VN, YU, ZA, ZM, ZW.
- (71) Applicant (for all designated States except US): **ELEMENT SIX LIMITED** [GB/GB]; Isle of Man Freeport, Ballasalla Isle of Man IM99 6AQ (GB).
- (71) Applicant (for MW only): **DONALD, Heather, June** [ZA/ZA]; Rochester Place, 173 Rivonia Road, Morningside, 2146 Sandton (ZA).

[Continued on next page]

(54) Title: METHOD OF INCORPORATING A MARK IN CVD DIAMOND

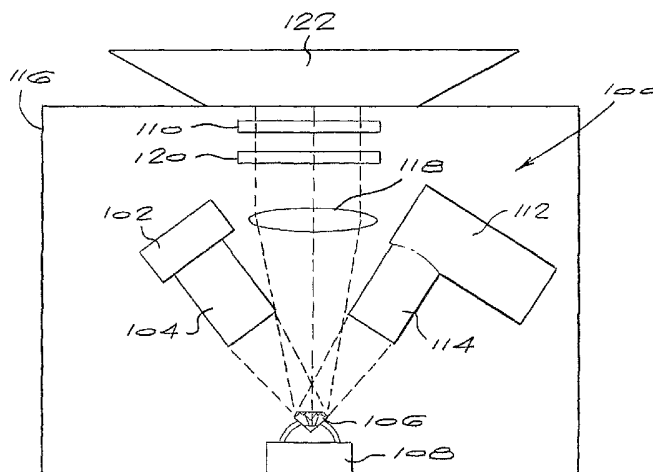

(57) Abstract: A method of incorporating a mark of origin, such as a brand mark, or fingerprint in a CVD single crystal diamond material, includes the steps of providing a diamond substrate, providing a source gas, dissociating the source gas thereby allowing homoepitaxial diamond growth, and introducing in a controlled manner a dopant into the source gas in order to produce the mark of origin or fingerprint in the synthetic diamond material. The dopant is selected such that the mark of origin or fingerprint is not readily detectable or does not affect the perceived quality of the diamond material under normal viewing conditions, but which mark of origin or fingerprint is detectable or rendered detectable under specialised conditions, such as when exposed to light or radiation of a specified wavelength, for example. Detection of the mark of origin or fingerprint may be visual detection or detection using specific optical instrumentation, for example.

WO 2005/061400 A1



(84) **Designated States** (*unless otherwise indicated, for every kind of regional protection available*): ARIPO (BW, GH, GM, KE, LS, MW, MZ, NA, SD, SL, SZ, TZ, UG, ZM, ZW), Eurasian (AM, AZ, BY, KG, KZ, MD, RU, TJ, TM), European (AT, BE, BG, CH, CY, CZ, DE, DK, EE, ES, FI, FR, GB, GR, HU, IE, IS, IT, LT, LU, MC, NL, PL, PT, RO, SE, SI, SK, TR), OAPI (BF, BJ, CF, CG, CI, CM, GA, GN, GQ, GW, ML, MR, NE, SN, TD, TG).

— *before the expiration of the time limit for amending the claims and to be republished in the event of receipt of amendments*

For two-letter codes and other abbreviations, refer to the "Guidance Notes on Codes and Abbreviations" appearing at the beginning of each regular issue of the PCT Gazette.

Published:

— *with international search report*

METHOD OF INCORPORATING A MARK IN CVD DIAMOND

BACKGROUND OF THE INVENTION

This invention relates to a method of marking or fingerprinting diamond material, in particular single crystal synthetic diamond material produced by chemical vapour deposition (hereinafter referred to as CVD), thereby providing a mark of origin or fingerprint in the diamond material, or a means by which its synthetic nature can more easily be determined.

Methods of depositing material such as diamond on a substrate by CVD are now well established and have been described extensively in patent and other literature. Where diamond is being deposited on a substrate, the method generally involves providing a gas mixture which, on dissociation, can provide hydrogen or a halogen (e.g. F, Cl) in atomic form and C or carbon-containing radicals and other reactive species, e.g. CH_x , CF_x wherein x can be 1 to 4. In addition, oxygen containing sources may be present, as may sources for nitrogen, and for boron. Nitrogen can be introduced in the synthesis plasma in many forms; typically these are N_2 , NH_3 , air and N_2H_4 . In many processes inert gases such as helium, neon or argon are also present. Thus, a typical source gas mixture will contain hydrocarbons C_xH_y wherein x and y can each be 1 to 10 or halocarbons $\text{C}_x\text{H}_y\text{Hal}_z$ wherein x and z can each be 1 to 10 and y can be 0 to 10 and optionally one or more of the following: CO_x , wherein x can be 0,5 to 2, O_2 , H_2 , N_2 , NH_3 , B_2H_6 and an inert gas. Each gas may be present in its natural isotopic ratio, or the relative isotopic ratios may be artificially controlled; for example hydrogen may be present as deuterium or tritium, and carbon may be present as ^{12}C or ^{13}C . Dissociation of the source gas mixture is brought about by an energy source such as microwaves, RF (radio frequency)

- 2 -

energy, a flame, a hot filament or jet based technique and the reactive gas species so produced are allowed to deposit onto a substrate and form diamond.

CVD diamond may be produced on a variety of substrates. Depending on the nature of the substrate and details of the process chemistry, polycrystalline or single crystal CVD diamond may be produced.

The development in the level of sophistication of methods of producing CVD single crystal diamond has meant that this material is becoming increasingly more suitable for use in industrial applications or in ornamental applications such as synthetic gemstones for jewellery. However, in many applications there is a need to provide a method of determining the source of synthetic diamond used in these applications in order to verify its origins or synthetic nature.

SUMMARY OF THE INVENTION

According to one aspect of the invention, there is provided a method of incorporating a mark of origin, such as a brand mark, or fingerprint in a CVD single crystal diamond material, which includes the steps of providing a diamond substrate, providing a source gas, dissociating the source gas thereby allowing homoepitaxial diamond growth, and introducing in a controlled manner a dopant into the source gas in order to produce the mark of origin or fingerprint in the synthetic diamond material, which dopant is selected such that the mark of origin or fingerprint is not readily detectable or does not affect the perceived quality of the diamond material under normal viewing conditions, but which mark of origin or fingerprint is detectable or rendered detectable under specialised conditions, such as when exposed to light or radiation of a specified wavelength, for example.

Detection of the mark of origin or fingerprint may be visual detection or detection using specific optical instrumentation, for example.

The mark of origin or fingerprint is preferably provided in the form of one or more layers or regions grown into the diamond material during synthesis.

Such a mark of origin or fingerprint in a CVD single crystal diamond material is most appropriate in CVD diamond which is of high commercial or gem quality. Synthesis of such high quality CVD diamond material is best performed using a diamond substrate having a surface on which growth takes place which is substantially free of crystal defects, and this forms a preferred version of the method of the invention.

In one embodiment of the method of the invention, the dopant is nitrogen, which produces a mark of origin or fingerprint, preferably in the form of a layer, that shows 575 nm and/or 637 nm luminescence peaks, with their associated vibronic systems, under suitable shorter wavelength excitation. The nitrogen doped layer may also show a photoluminescence line at 533 nm.

In an alternative embodiment of the invention, the dopant is a combination of nitrogen and boron, where the boron is preferably present in a higher concentration than the nitrogen, which produces a mark of origin or fingerprint, preferably in the form of a layer, that generates characteristic phosphorescence, peaking typically in the range of 400 nm to 500 nm, under suitable shorter wavelength excitation.

In a particularly preferred embodiment of the invention, a combination of layers that generate 575/637 nm luminescence and 400 nm to 500 nm phosphorescence under suitable shorter wavelength excitation is grown into the diamond material during synthesis.

A further alternative embodiment of the invention is the marking of a layer or region with the centre which emits 737 nm radiation under optical excitation. The exact identity of this optical centre is uncertain, although it is believed to involve silicon; it will hereafter be referred to as the 737 nm

- 4 -

silicon related centre. Whereas the luminescence at 575/637 nm and the phosphorescence in the range 400 nm to 500 nm can easily be detected by eye under suitable viewing conditions, the detection of the luminescence from the 737 nm silicon related line is generally more easily detected using specific optical instrumentation with an integrated detector, and typically giving an output in the form of an analogue display.

In accordance with a further aspect of the invention there is provided a CVD single crystal diamond material bearing a mark of origin or fingerprint in the bulk thereof, which mark of origin or fingerprint is grown into the diamond material during the synthesis thereof, preferably in accordance with the method described above.

The single crystal diamond material may be prepared for a range of industrial applications, in particular those in which the synthetic diamond material is a visible element to the user, or where the synthetic diamond element is re-useable or needs periodic reprocessing, as is for example the case with diamond cutting blades such as scalpels.

Alternatively, the single crystal diamond material may be prepared or suitable for preparation as a synthetic gemstone for jewellery applications.

The invention also extends to an apparatus for detecting the mark of origin or fingerprint in a CVD single crystal diamond material, object or synthetic gemstone, the apparatus comprising:

a source of light or radiation of a particular wavelength for causing excitation of the mark of origin or fingerprint, resulting in luminescence and/or phosphorescence thereof; and

a detection means for detecting the mark of origin or fingerprint, for example a viewer for viewing the luminescence and/or phosphorescence, or an instrument providing a measure of the intensity of the specific luminescence and/or phosphorescence, in

- 5 -

forms such as an analogue or digital electrical signal, or display readout, for example.

The apparatus preferably comprises a range of optical filters for viewing the wavelengths emitted by the mark of origin or fingerprint, and means for excluding background white light or wavelengths used to excite the fingerprint or mark of origin, or any other background wavelengths present which may be detrimental to observing the wavelengths emitted by the mark. The characteristic luminescence and/or phosphorescence may be viewed in the form of a special image detectable directly in the diamond material, or it may be viewed by using instrumentation such as a charge coupled device (ccd) or imaging device such as a digital camera. Alternatively, the luminescence and/or phosphorescence may be characterised by a spectroscopic device such as one or more specific band pass filters and/or frequency specific sensors, or a compact spectrometer. These techniques can be combined, for example using suitable filters in combination with a ccd camera to form frequency specific images.

The apparatus may also include magnification means for magnifying the image of the synthetic diamond material.

DESCRIPTION OF PREFERRED EMBODIMENTS

The invention provides a method of marking synthetic diamond material, in particular such material prepared for use in industrial applications such as cutting tools or as a CVD synthetic diamond gemstone. The method of marking enables the determination of origin, said mark of origin or fingerprint comprising one or preferably more layers grown into the diamond during synthesis, which do not substantially affect the perceived optical or gem qualities of the diamond under normal viewing, or significantly affect any other application specific properties relating to the intended application, but which can be viewed under special viewing

- 6 -

conditions. For convenience, the layer or layers comprising this mark of origin or fingerprint may be referred to as tagging layers.

Throughout this specification, the terms 'fingerprint' or 'mark of origin' are deemed to include features which provide one or more of the following benefits:

- a) basic identification of the synthetic nature of the material;
- b) identification of the manufacturer, or the method of manufacture;
- c) a brand mark or other characteristic mark;
- d) a batch mark or date stamp;
- e) a means by which post processing or modification of the diamond or article formed from the diamond can be detected.

The fingerprint or mark of origin must also be relatively simple to apply to or incorporate in the material, and similarly be observed or detected in a relatively unskilled operation using simple, low cost, compact and relatively portable equipment. By low cost, it is meant that the equipment is preferably <\$10,000, and more preferably < \$5,000, and even more preferably < \$2,000, and even more preferably < \$1,000. On this basis, means of marking solely based on varying the isotopic ratios of elements in the diamond away from natural abundance are specifically excluded. Isotope variation to mark material is known in a large range of materials, particularly in laboratory methods. In diamond such methods include two possible variants.

- 1) Varying the isotopic abundance of the carbon, i.e. using a carbon source which is isotopically enriched in ^{12}C or ^{13}C . The problem with this is twofold:
 - a. isotopically enriched ^{12}C or ^{13}C source gases are very expensive, adding substantially to the cost of manufacture, and
 - b. detection of isotopic variation requires complex and expensive equipment and a high level of skill to operate and interpret. Furthermore most techniques predominantly look

- 7 -

at surfaces and local features, rather than the bulk and pattern of features throughout the bulk. Specific techniques include secondary ion mass spectroscopy (which also damages the sample), Raman analysis possibly combined with confocal techniques, and high resolution X-ray diffraction, etc.

- 2) Varying the isotopic ratio of another element in the diamond such as nitrogen. Such a technique is predominantly relevant to HPHT synthetic diamond where the concentration of nitrogen and other elements can be relatively high, for example nitrogen can be in the range of 100 – 800 ppm. The problems with this are similar to those with carbon isotope variation, in that:
 - a. isotopically enriched gases are expensive, adding to the cost of manufacture
 - b. detection is complex, expensive and skilled. Detection is further complicated in typical CVD diamond by the low concentration of impurity elements in the diamond, often below 1 ppm in the solid, so that some techniques which may be applicable to HPHT diamond are not suitable for CVD diamond.

Consequently, whilst in some instances there may be reasons to combine an isotopic variation with the method of this invention, for example to provide additional features which are less easily detected, this invention excludes the required use of isotopic variation. Within this specification, isotopic dopants refers to dopants where the isotopic abundance is deliberately different from the natural isotopic abundance, so as to confer a detectable variation in isotopic abundance in the material. Chemical dopants refers to dopants which provide different chemical elements, so as to confer a detectable variation in the elements within the material, at least in the form of defect centres characteristic of these other elements.

- 8 -

Furthermore, detection of the fingerprint or mark of origin under specialized viewing conditions refers to detection of light of a characteristic wavelength or colour emitted by the mark under the specialized conditions and detected directly by the eye of the observer, or indirectly via optical detection means that then provide some means of human detectable output, generally a visible analogue output although this may be converted to an indication of whether the signal is above or below a threshold by the detection instrument. Generally the preferred method of detection is directly by the eye of the observer, since this provides the opportunity for spatial information, including binocular or depth information, and provides a particularly inexpensive solution. In the case of one specific example given later, the 737 nm silicon related line, the eye is generally not sufficiently sensitive to detect the typical levels of emission achieved, and a simple method of wavelength selection and then optical energy detection may be preferred, and can still be provided in simple, low cost, compact and relatively portable equipment.

By way of example, diamond scalpel blades are often re-useable, periodically returning to the manufacturer for preparation of a new edge. Used in this application, the mark of origin or fingerprint can fill one or more of the following functions, although its purpose may not be limited to these examples:

- a) Enable the specific manufacturer of the synthetic diamond scalpel to be identified, either by the manufacturer or by the marketplace. This can be used by the manufacturer to ensure that only his own blades are accepted for reprocessing, and improve the ability to track such blades within the reprocessing or in the marketplace at large.
- b) Provide a means by which to generate a distinctive mark, such as a trademark, without degrading the material in its final application. Ordinarily visible identification marks on the synthetic diamond scalpel blade may not be acceptable for some applications

- 9 -

because of requirements of hygiene, uniform transparency, or simply market expectation or acceptance.

- c) Enhance the identification of the synthetic nature of the diamond material. Synthetic diamond can offer greater reproducibility and control in many industrial applications, thus offering a better product.
- d) Provide a means by which modification of the synthetic diamond material may be identified, such modification including changes to physical shape and annealing treatments such as those which modify colour.

By way of further example, in the application of CVD diamond in synthetic gemstones, the mark of origin or fingerprint can fill one or more of the following functions, although its purpose may not be limited to these examples:

- a) Enable the specific manufacturer of the CVD synthetic gemstone to be identified, either by the manufacturer or by the marketplace.
- b) Provide a means by which to generate a distinctive mark such as a trademark.
- c) Enhance the identification of the synthetic nature of the diamond material.
- d) Provide a means by which modification of the CVD synthetic diamond material may be identified, such modification including changes to physical shape and annealing treatments such as those which modify colour.

The exact function of the mark of origin or fingerprint typically determines the form of the mark that is preferred:

- 10 -

In its simplest form the mark may merely comprise a substantial portion of the diamond layer, object or synthetic gemstone, or a single broad layer within it, exhibiting an unnatural characteristic which is only observable under specific artificial conditions of observation and does not significantly affect the colour of any object prepared from the layer under normal illumination. The obviously artificial element to the mark may result from its colour, possibly in combination with the specific artificial conditions applied in order to observe the colour, or the geometry of the boundaries or distribution of the marked layer within the whole layer, primarily observed as the geometry with which it intercepts the boundaries of the layer, object or synthetic gemstone, or in the way it influences the appearance of an object of given geometry when viewed from one or more specific viewing angles.

In a more complex form, in order to generate a distinctive mark such as a trademark, the mark of origin or fingerprint generally comprises one or more sets of characteristic layers, either distributed periodically throughout the diamond layer, object or synthetic gemstone or, in the case of a single set of characteristic layers, placed in an appropriate location; generally not too near one of the edges of the object such that minimal removal of material will remove it, nor generally such that the mark is concealed and made difficult to observe by components essentially permanently attached to the object in normal use. In the case of a synthetic gemstone, a single set of characteristic layers may be located near the middle of the thickness of the cut stone, or if biased away from the middle then preferably biased in order to enhance the intended benefit of the layer.

The ideal location of a layer within a gemstone is dictated by a number of considerations:

- a) The tagging layer should not be easily removable, and thus not wholly close to an external surface such as the table or culet.

- 11 -

- b) The tagging layer should not provide visible colour to the gemstone. The effect of the tagging layer on the colour of the gemstone will depend on the intrinsic optical absorption properties of the tagging layer material and the path length within the layer of light rays reaching the eyes of the viewer. The latter depends on position and thickness of the layer. It is also a function of the cut of the stone, although generalizations are possible.
- c) The tagging layer should be positioned so that in any mount not normally easily removed, such as a jewellery setting, the volume of the layer can be efficiently excited by a deliberately applied external light source used during identification, the key point being that this light distribution may differ from that in normal viewing conditions, being for example a high intensity parallel beam rather than more diffuse.
- d) The tagging layer should be positioned so that in any mount not normally easily removed, such as a jewellery setting, a significant proportion of the light emitted by the tagging layer is made available to the viewer or other means of detection. Whilst this may seem self-evident, the angle for total internal reflection in diamond is only 22.4° away from normal incidence due to its high refractive index and this gives some unexpected results, discussed further below. Again this is a sensitive function of the cut of the stone, but generalizations can be made.
- e) Aspects (b) – (d) interact, such that ideally the tagging layer, or the majority volume of it, is placed at that position in the final synthetic gemstone which is most effectively illuminated and which most efficiently passes back the emitted radiation to the viewer or detection system, but which does not provide excessive enhancement of the effect on the visible colour of the stone.

- 12 -

The effect of total internal reflection on the viewing of luminescence arising from the volume of a CVD diamond plate or stone will now be considered. As an example, consider a rectangular flat plate with precise flat faces all of the type {100}. An external light beam of given direction will pass into the diamond whatever its direction, refraction resulting in it being bent to much closer to the normal to the interface at the interface. It may possibly be internally reflected once by a face parallel to a different axis but will then exit the sample again, essentially exiting after a single pass through the material. However, when luminescence arises in the volume of the stone its direction of emission is generally equally distributed throughout the solid angle (although it is possible to identify defects with a non-uniform pattern of emission). Imagine then the 4π solid angle of the uniform irradiation field, interacting by total internal reflection with the faces of the plate. Any radiation not within 22.4° of the normal of one of the 3 face types ({100}, {010}, {001}) will be permanently totally internally reflected. Now imagine a small corner facet. This will be able to emit all radiation internally incident on it within 22.4° of its normal from the entire volume of the sample, very little of this radiation escaping through the main faces of the plate. Thus, in this case, strong emission is observed from facets which are not parallel to the main facets. However, at each facet which is emitting the emitted light is refracted to largely fill the hemisphere of solid angle centred on the normal to the plane of the facet. From this simple example it is clear that the behaviour of the excitation source passing into a three dimensional diamond object and the emission of light generated within it can be distinctly different.

As a further example to put this into context, in a typical round brilliant cut synthetic diamond gemstone, a layer near the table is generally likely to affect the visible colour of the stone and be relatively easily excited by a specific source, but may not provide good intensity in the emitted beam out through the table because all light more than 22.4° away from the normal to the table will be totally internally reflected, then possibly exiting the stone below the girdle. In contrast, a layer near the culet will generally impact less on the visible colour of the stone, may require more careful control of

- 13 -

the excitation beam angle and distribution in order for it to be effectively excited, but may be more effective in providing emission of luminescence through the table as a result of total internal reflection at the pavilion facets below the girdle towards the culet.

One particular type of layer is one in which the prime active impurity is nitrogen in the form of NV^0 and NV^- centres that generate 575 nm and 637 nm luminescence lines respectively, together with their associated vibronic bands, under suitable shorter wavelength excitation. The combination of these emissions appears orange/red and is generally referred to as 'orange luminescence'. Such luminescence extinguishes essentially instantaneously when the excitation source is removed. Whilst clearly visible under suitable artificial illumination conditions, under normal viewing conditions and with appropriately chosen defect concentrations and/or total defect numbers as envisaged in this invention, this type of centre does not significantly alter the perceived colour of the gemstone.

Another particular type of layer is one in which the dominating impurities are boron and a suitable donor such as nitrogen. Donor-acceptor pair recombination may occur in such a layer and the layer then exhibits characteristic blue luminescence over a broad band peaking in the range 400 nm to 500 nm, typically in the region of 500 nm under suitable shorter wavelength excitation. Phosphorescence builds up and then saturates with time during the period under the excitation source, and is visible as its intensity decays for a period of time after the removal of the excitation source, the time period typically being several seconds although it can be as long as a minute or more. In this type of layer the nitrogen has two important roles: providing the donor for donor/acceptor pair recombination and, by compensating the boron, reducing the B-related absorption which might otherwise cause observable blue colour. With suitable artificial illumination conditions donor-acceptor luminescence and phosphorescence may be clearly visible for a layer that, under normal viewing conditions, does not significantly alter the perceived colour of the diamond object.

- 14 -

Other donors, such as intrinsic defects, may contribute to this type of luminescence and phosphorescence.

A particularly advantageous arrangement would be where these two types of layer are both present, possibly used alternately or in some other pattern, within unmarked material. Alternatively, one type of layer, preferably the orange luminescent layer, may fill substantially all the volume not occupied by the other. Shorter wavelength excitation can then be selected to excite both the (575 nm / 637 nm) orange luminescence and the (500 nm) blue-band phosphorescence, or a suitable combination of wavelengths can be used.

The method of viewing the mark is in part related to the excitation wavelength(s) used. Using sub-bandgap illumination (i.e. light with insufficient energy to excite electrons right across the band gap in diamond, and thus not normally absorbed by diamond itself), the radiation would be transmitted through the volume of the stone, being absorbed only by the defects in the doped marker layers, enabling the volume of the doped marker layers to be excited. Since the wavelengths emitted from the layers are also transmitted by diamond (although some absorption may occur in the defects in the layers) the person viewing the stone would be able to see, for example by viewing through the table of the stone, a substantial area of the layer which is emitting the colour within the diamond volume.

On switching off the excitation source, since the orange luminescence turns off with the excitation source, the perceived colour of the light emitted from the CVD diamond material, or the tagging layers within it, would change from orange, or some orange/blue combination, to blue. This will be termed the orange/blue flash. The visibility of such a change in colour, particularly the visibility of the orange component against the blue phosphorescence, may need to be enhanced by use of suitable filters. Sub-bandgap illumination would be the preferred excitation wavelength for simple demonstration of the existence of the mark in the piece of synthetic gemstone, allowing its detection through the table of a cut stone even when

- 15 -

the layers are significantly further down in the material. In some instances where the material is formed in the shape of a synthetic gemstone it may be preferred to place these layers below the girdle of the stone, so that the edges of the layers are generally concealed by the mount. In other instances it may be preferred to place the layers above the girdle, allowing these edges to be viewed on the crown facets. The closer to the centre of the synthetic stone the layers are positioned, the more difficult it is to remove the mark by repolishing the stone without significant weight loss. The orange/blue flash is particularly characteristic of the combination of these particular marking layers. It provides a unique characteristic not seen in natural diamonds or likely to occur accidentally in synthetic stones. Those skilled in the art will understand that other colour combinations may be possible using other types of defects in the diamond material, and that the invention is not limited to any particular colours and or viewing conditions, but extends generally to any viewable distinctive mark not normally observed in natural diamond which does not substantially degrade the visual characteristics of the layer or gemstone under normal viewing conditions.

Using above-bandgap illumination (i.e. light with sufficient energy to excite electrons right across the band gap in diamond), the diamond material would itself directly absorb the incoming radiation and limit the penetration depth to near the surface of the stone. This would potentially limit the visibility of the layers to those areas close to the surfaces of the stone which are directly exposed to the artificial illumination. Two effects may broaden the region in which the illuminating irradiation is absorbed or a response observed, the first is where the excitation radiation is near-bandgap, so that the attenuation of the radiation in the diamond material is rising but is not yet limiting the penetration to a few microns depth at the surface, and the second is where charge carriers excited at the surface by the incoming radiation are able to drift further into the diamond item and then cause excitation of the layers further into the bulk. The ability for this to happen depends on a variety of factors including the general purity and

- 16 -

crystal perfection of the synthetic diamond material outside the specifically marked layers.

However, the benefit of using above-bandgap radiation is generally to limit the region excited to the surface of the diamond item and thus provide greater definition of the pattern of the layers, although viewing this detail often requires more sophisticated viewing equipment, particularly in view of the thickness of the layers. In this domain, viewing only the exposed edges of the layers and considering the specific example of using alternate orange luminescing and blue phosphorescing layers, both layers would be visible during excitation but only the layers showing blue-band phosphorescence would be visible after the excitation ceased. Above-bandgap illumination is particularly useful in a) enabling the detailed geometry of a mark intended as a trademark to be observed, and b) where the geometry of the layers is used to emphasise the synthetic nature of the material where the colour or colours, spatially or temporally separated, alone may not be sufficient.

Where a single marking layer is used, this may occupy a substantial volume of the whole layer, object or synthetic gemstone. Where one or more layers are used in a single group or pattern then the lower bound of the thickness of each of the layers would typically exceed 10 μm , more typically exceed 20 μm , even more typically exceed 50 μm , even more typically exceed 100 μm , and most typically exceed 200 μm , and the upper bound of the thickness of each of the layers would typically be less than 1000 μm , more typically be less than 600 μm , even more typically be less than 400 μm and most typically be less than 250 μm , the basic criteria being that for the concentration of impurities used and the associated absorption and luminescence characteristics, the layers are thin enough so as not to significantly colour the cut stone when viewed under normal light, whilst being sufficiently thick to provide sufficient visibility under the selected excitation wavelengths. An additional requirement may be for the layers to be thick enough for their geometry to be precisely measurable, for example using an above band gap viewer as described earlier. A further combination is where one marking layer or characteristic feature extends

throughout the majority or the whole of the diamond object except where a second layer is formed within this region.

Where one or more layers are used in multiple or a repeating pattern spread through the volume of the stone then the individual layers may be thinner, a key parameter being the total thickness of all the layers of the same type. In such circumstances the lower bound of the thickness of each of the layers would typically exceed 2 μm , more typically exceed 5 μm , and most typically exceed 10 μm , and the upper bound of the thickness of the layers would typically be less than 100 μm , more typically be less than 50 μm , even more typically be less than 20 μm .

In particular, excluding for the moment the geometrical issues described earlier arising from the effect of total internal reflection, viewing near normal to the plane of the marked layers using sub-bandgap radiation, the critical parameter would be the concentration of emitting centres through the thickness of the layer projected onto the plane of the layer. That is, the observed brightness of the layer would be proportional to the product of the intensity of the exciting radiation, the concentration per unit volume of the irradiating centre, and the thickness of the layer. Other effects can also contribute to the observed intensity, including the effect of self absorption elsewhere in the material. Thus thicker layers would be preferred where concentrations of dopants were very low. Such conditions may be favoured by the requirement to have minimal impact on the overall growth process.

In contrast, viewing the edges of the layers in above-bandgap excitation, the depth of material sampled would be largely fixed by the radiation wavelength and thus the observed brightness would be proportional to the product of the intensity of the exciting radiation and the concentration per unit volume of the relevant defect centres, with the thickness of the layer determining the lateral extent of the area emitting. Thicker layers may again assist in improving visibility where concentrations of dopants are low, by increasing the area to be observed.

- 18 -

A third case is when viewing near normal to the plane of the marked layers using sub-bandgap radiation in a cut gemstone. This is described in more detail later, where total internal reflection on the lower facets dominates the behaviour. Here, although the viewing direction is apparently normal to the plane of the layer, the beam actually being observed is largely parallel to the layer until total internal reflection occurs, so that the critical parameter would be the concentration of emitting centres through the thickness of the layer projected onto the plane of the layer. That is, the observed brightness of the layer would be proportional to the product of the intensity of the exciting radiation, the concentration per unit volume of the irradiating centre, and the lateral extent of the layer. Other effects can also contribute to the observed intensity, including the effect of self absorption elsewhere in the material.

Useful concentrations of the various impurities have been evaluated and found to be as detailed below. However, those skilled in the art will understand that there is considerable interaction between the type of growth process used, the concentration of other impurity centres or structural defects which may for example result in quenching of luminescence or a change in the charge state and thus the optical behaviour of the impurities used for the tagging layers. In addition, it is well known that the uptake of impurities varies with the specific growth sector of diamond involved, for example the {111} growth sector often taking up higher concentrations of impurities than the {100} growth sector. For simplicity the data given below relates to the {100} growth sector and requires suitable modification where other growth sectors are involved.

Thus, using a microwave process such as that detailed in Example 1, it has been found that for generating the 575 nm luminescence at levels suitable for tagging, whilst reducing the effect on colour and visible absorption to acceptable levels, the optimum value of the molecular nitrogen concentration in the gas phase lies in the range having an upper limit of preferably 10 ppm, more preferably of 3 ppm, even more preferably of 1 ppm, even more preferably of 0.5 ppm and most preferably of 0.2 ppm,

- 19 -

and a lower limit of preferably 0.01 ppm, more preferably 0.05 ppm, and most preferably of 0.1 ppm. In terms of the nitrogen incorporated into the solid of the material, this is not always easy to characterize in diamond at these low levels but is generally measured in terms of atomic fraction to be about $10^3 - 10^4$ lower than that of the molecular concentration in the gas phase. Molecular nitrogen is not the only useful source of nitrogen, for example NH_3 would also be of use, although the relative activation/incorporation of the N may then be different.

Likewise, using a microwave process such as that detailed in Example 1, it has been found that for generating B/N donor acceptor pair phosphorescence at levels suitable for tagging, whilst reducing the effect on colour and visible absorption to acceptable levels, the concentration of both boron and nitrogen needs to be controlled. In particular, the concentrations of B and N in the solid are preferably within a factor of 30, and more preferably within a factor of 10, even more preferably within a factor of 5, even more preferably within a factor of 3, and most preferably within a factor of 2, preferably in each case with the concentration of the boron exceeding the concentration of the nitrogen. One benefit of this is that the nitrogen compensation of the boron reduces the effect that the boron has on the colour of the material. A further limit is provided by evaluating the effect of the boron on the visible colour. Experimentally it has been determined that uncompensated boron provides a visually detectable blue colour when present in a round brilliant as a layer where the product of the thickness of the layer and the uncompensated boron concentration in that layer exceeds 0.1 ppm.mm (e.g. 1 mm thickness of 0.1 ppm uncompensated boron or similar). Phosphorescence however can be generated in layers with much lower levels of boron, with suitable levels of phosphorescence having been observed in 200-400 μm thick layers with concentrations of boron in the solid of 0.01 ppm to 0.001 ppm, with the indication that even lower levels may be sufficient.

It has been determined experimentally that the phosphorescence intensity arising from boron/nitrogen donor acceptor pair recombination can be

- 20 -

reasonably approximated as the sum of two second-order decays, each with a characteristic time constant. The form of this is given below:

$$I/I_0 = A/(1+t/\tau_1)^2 + (1-A)/(1+t/\tau_2)^2$$

It should not be assumed from the observation that the data can be fitted to an equation of this form that there are two, or only two, distinct types of centre present. In some cases there is only one time constant with a significant amplitude. However, it is generally found that where two time constants can be found, they differ by a factor of about 8 to 10. At higher concentrations of boron, the longer time constant is generally still relatively short, typically under 2 seconds and often under 1 second. At lower concentrations the slower decaying component generally becomes more dominant and its time constant increases to greater than 3 seconds. This has three related advantages:

- a) the integrated pumping period effectively increases in proportion to the decay time constant (phosphorescent decay observed just after removing the excitation beam could have been excited a longer time ago);
- b) the intensity at any given time after excitation as a consequence increases; and
- c) typically for optimum detection by eye the intensity needs to be visible for at least 2-3 seconds.

The relationship between boron concentration and the value of the longer time constant is not fully determined, but under test conditions used, for example as in Example 1, boron concentrations below 0.1 ppm in the solid seem particularly beneficial.

- 21 -

Thus the preferred concentration of boron in the solid lies in the concentration range with an upper bound of 1 ppm, more preferably 0.3 ppm, even more preferably 0.1 ppm, even more preferably 0.05 ppm and most preferably 0.02 ppm, and with a lower bound of 0.0001 ppm, more preferably 0.0003 ppm, even more preferably 0.001 ppm, even more preferably 0.002 ppm, and most preferably 0.005 ppm. The incorporation ratio of the boron is typically such that the preferred values for the molecular concentration of diborane in the gas phase are a factor of 10 higher than these values.

As is generally well known, the incorporation ratio for nitrogen is much lower than that for boron. As a consequence, whilst the optimum concentration in the solid may be close to but below that of the boron for enhanced phosphorescence, the concentration in the gas phase is generally much higher. Typically the concentration range for the nitrogen is chosen to meet the other criteria – that is the boron concentration in the solid is first set and then the relative concentration of the nitrogen in the solid set, thus largely determining the concentration of nitrogen to add to the gas phase dependent on the exact incorporation ratio achieved under the growth conditions in use. However, preferred values for the molecular nitrogen concentration in the gas phase for the production of the blue phosphorescent layer lie in the range bounded by an upper limit of preferably 50 ppm, more preferably 20 ppm, even more preferably 10 ppm, even more preferably 5 ppm and most preferably 2 ppm, and a lower limit of preferably 0.02 ppm, more preferably 0.05 ppm, even more preferably 0.1 ppm, even more preferably 0.2 ppm and most preferably 0.5 ppm. Again, molecular nitrogen is not the only useful source of nitrogen, for example NH_3 would also be of use, although the relative activation/incorporation of the N may then be different.

In the case of the Si-related 737 nm centre, the nature and behaviour of this defect is less well understood at this time, however again very low concentrations of silicon, of the order of 10 ppm to 0.0001 ppm, are believed to be suitable to generate the defect in sufficient quantity, provided

- 22 -

the other necessary components are present. One particular issue is thought to be the charge state of the defect; in the presence of boron the charge state may change from the state needed for 737 nm luminescence, whilst the presence of nitrogen may help to stabilize the defect in the correct charge state. Models for the defect include a substitutional Si with an adjacent vacancy in the neutral charge state, a silicon vacancy complex, and two substitutional silicon atoms along the $\langle 111 \rangle$ axis bound with vacancies. The total integrated intensity of luminescence from the Si-related centre is typically much less than for the NV^0 and donor-acceptor luminescence and phosphorescence. In addition, it lies in a region of the spectrum (737 nm) where the eye is less sensitive. Consequently the primary methods for its detection involve spectroscopic instruments rather than direct viewing. Detailed layer structures in the incorporation of the Si-related centre are less advantageous because they are harder to view or identify in other ways. That said, the 737 nm line can be viewed in systems using, for example, electronically enhanced imaging, particularly in combination with the use of suitable filters, and layer structures can also be detected by means such as confocal luminescence depth profiling over a limited wavelength region or combined with spectroscopic analysis. The 737 nm Si related centre has a complex set of excited states and can thus be excited by a range of different laser wavelengths including 488 nm and 514 nm, and is particularly efficiently excited by the 633 nm HeNe laser. However, other light sources with wavelengths in the range 480-700nm would be suitable.

Suitable sub-bandgap wavelengths for viewing the marks or tagging layers can be determined as follows. Orange luminescence (from the 575 nm and 637 nm optical centres) can be excited by a range of wavelengths such as 514 nm, 488 nm and shorter wavelengths, but excitation efficiency is reduced as wavelengths approach the UV and it is worth noting that the 637 nm centre is not excited by wavelengths below about 400 nm. In contrast, blue-band phosphorescence is more efficiently excited by wavelengths approaching the short UV, such as the mercury line at 254 nm. These trends in the efficiency of excitation are not particularly

- 23 -

limiting, however, and a range of wavelengths can be used to excite both emissions sufficiently well.

Suitable above-bandgap radiation for viewing one or more tagging layers in the near-surface region would be at 193 nm and shorter wavelengths. Generally high luminance sources can be used and good spatial resolution still obtained because of the strong attenuation in the diamond. An instrument particularly suited to precise viewing and characterisation of the layers using above bandgap UV radiation is the 'DiamondView™' instrument, developed by the Diamond Trading Company which combines a suitable UV source with digital image capture and allows the study of both luminescence and phosphorescence in diamond samples even down to relatively low luminosity levels.

The optical characteristics when viewed using suitable conditions, or the spatial distribution of those regions providing the optical characteristics, or the combination of these two, provide a distinction from other forms of diamond such as natural diamond or CVD diamond known in the art. In this respect, whilst phosphorescence in natural blue diamonds is known, and orange luminescence, although relatively rare, is also known in natural stones, they are not known to exist in the same natural stone, nor are they known in the form of clearly defined layers in natural stones and there is no known example of natural diamond that shows the 737 nm silicon-related line.

It has been determined that the orange/blue flash effect may best be observed by exciting and identifying the orange 575 nm and blue luminescence/phosphorescence bands separately. The rationale for this is now discussed.

When a phosphorescent centre is present and excited by a suitable excitation wavelength, the phosphorescent centre is not only visible after the illumination is removed, but also whilst the illumination is on. This apparent luminescence from the phosphorescent centre will be stronger

- 24 -

than any subsequent phosphorescence after the excitation source is removed, by a degree dependent on the lifetime of the centre and the time of measurement. Consequently, even a relatively weak phosphorescent centre can result in significant luminescence whilst the source is on.

Considering the use of a single wavelength or band of wavelengths to excite both orange luminescence and blue PL/phosphorescence, it has been noted that if the blue luminescence band is present in considerable strength, then this can make simultaneous observation of the 575 nm band extremely difficult. If an attempt is made to block the blue PL and observe the 575 nm region through a suitable filter (e.g. OG550) then a false impression of orange '575 nm PL' would be observed as the long wavelength tail of the blue luminescence would also be transmitted by the filter. There may also be additional confusion, as when the excitation source is switched off the long wavelength tail of the blue phosphorescence band would be observed through the filter.

Thus, the test for orange 575 nm luminescence should ideally be determined first followed by the test for blue phosphorescence. It is inadvisable to excite the blue phosphorescence first as this may take up to a minute to decay to a level where 575 nm luminescence may then be excited and observed. 575 nm luminescence may be excited with wavelengths in the range 225 nm to 575 nm but may only be excited without also stimulating blue luminescence/phosphorescence in the range 300 nm to 575 nm. The strength of the 575 nm emission depends on the CVD synthetic having a suitably high concentration of 575 nm centres in the tagging layer and/or a sufficiently thick layer. Wavelengths of excitation greater than about 380 nm are within the spectral response of the eye. This could severely affect the observation of the 575 nm band. In this case, a suitable filter is required to substantially or completely block the excitation source from reaching the eye of the person who is viewing the 575 nm band.

- 25 -

The test for 575 nm luminescence is then followed by the test for blue phosphorescence. The 575 nm excitation source and the viewing filter should be removed. Shortwave ultraviolet excitation at a wavelength or within a wavelength band in the range 225 nm to about 254 nm should then be switched on to excite any blue luminescence. The 575 nm band will also be stimulated by the shortwave excitation, but will almost certainly be dominated by blue PL. After several seconds the shortwave excitation should be switched off and blue phosphorescence observed. There will be no contribution from the 575 nm centre which does not show phosphorescence. If by using this sequential excitation method the orange/blue flash is observed then the stone under test is a tagged CVD synthetic with the specific structure described earlier.

A particularly advantageous form of inexpensive viewer for general detection of the presence of the mark in this invention would combine a small box to fit over the CVD diamond layer, object or synthetic gemstone to exclude ambient light, with an excitation light source entering the box and a viewing window, possibly in the form of a magnifying lens, with a filter to remove the excitation wavelength. Alternatively ambient white light could also be removed by filters rather than excluded from the viewing box, with the filters then being essentially band-pass filters for the orange luminescence and blue-band phosphorescence.

Sub-bandgap illumination would be the preferred excitation method for the simple demonstration of the existence of tagging layers/marks in the piece of synthetic diamond material for example by the orange/blue flash effect. Sub-bandgap illumination would penetrate the whole volume of the synthetic stone and therefore permit excitation of tagging layers at any location within it. Tests have shown that in general the whole volume of the stone is equally illuminated, even using an excitation beam introduced from one side only, since the resultant image of the luminescence is not sensitive to the position/direction of the excitation beam. This method of excitation allows detection of the luminescence through the table of a cut

stone even when the layers are significantly buried within the material and from a cut stone in a rub-over jewellery setting.

The invention will now be discussed with reference to the following Figures:

Figure 1

A graph covering the visible wavelengths in the range 400 to 800 nm and containing three spectra: a) a curve centred about 450 nm (labeled 450F x XEF) is the excitation beam generated by the xenon flash lamp after filtering by an Andover 450 nm filter, b) the rising edge of the band pass region of the OG 550 viewing filter at about 550 nm (labeled OG550), used to remove any of the excitation frequencies from the viewed image, and c) the emission spectrum of the 575 nm PL centre as viewed through the OG550 filter (labeled OG550 x 575) peaking in the region of 620 nm

Figure 2

A graph covering the range 200 to 800 nm showing two spectra, a) the curve centred about 228 nm which is the excitation beam generated by the xenon flash lamp after filtering by an Andover 228 nm filter, and b) the emission spectrum of the blue PL/phosphorescence centre which peaks near 500 nm and extends from 400 nm to 700 nm.

Figure 3

A graph over the range of 200 nm to 700 nm showing the excitation spectra for a) the 575 nm band and b) the 637 nm band, up to the intrinsic diamond band edge (defining the diamond band gap). This data and is taken from Zaitsev A., Optical Properties of Diamond: a data handbook, Springer, 2001 (ISBN 354066582X)

Figure 4

A graph over the range of 200 nm to 500 nm showing three spectra: a) the curve extending across the whole wavelength range is the emission spectrum of a Hamamatsu xenon flash lamp. The radiation from the xenon flash lamp is dominated by intense visible emission bands in the long wave

- 27 -

range 400 nm to 550 nm and very intense short wave ultraviolet emission bands in the range 220 nm to 270 nm, b) the transmission curve for a narrow bandpass filter supplied by LOT Oriel, UK and manufactured by Andover Corporation, USA, type 228 FS 25-25, with a peak wavelength centred at 228 nm, full bandwidth at half maximum of about 25 nm and diameter of 25 mm, and c) the transmission curve for a narrow band transmission filter supplied by LOT Oriel, UK and manufactured by Andover Corporation, USA, type 450 FS 40-25, with a peak wavelength centred at 450 nm, full bandwidth at half maximum of about 40 nm and diameter of 25 mm.

Figure 5

A schematic representation of a suitable viewer for observing the 575 nm orange fluorescence (upper image) and blue (blue-green) phosphorescence (lower image) of a tagged synthetic cut as a gemstone. The upper image (labeled '575 nm orange fluor.')

The figure is a schematic diagram of a viewer instrument. It shows a central viewing window at the top, labeled 'open', which is intended for a glass or Perspex filter. Below this window are two filter positions, F1 and F2, which are tilted at approximately 45 degrees from the vertical. The lower part of the viewer contains two image areas: the upper one is labeled '575 nm orange fluor.' and the lower one is labeled 'blue-green phos.'. The entire instrument is supported by a base. The text describes the components and their functions: a xenon flash lamp as the source, a 450 nm excitation filter (F1), an orange viewing filter (OG550, F3), and an additional filter (F4) to reduce scattered light. The lower image area is used for observing blue phosphorescence, excited by a 228 nm filter (F2).

Figure 6

A schematic side elevation of the viewer shown in Figure 5. The viewing filters are placed at approximately 45 degrees from the vertical and set away from direct excitation to prevent the operator viewing the source directly and to eliminate the production of luminescence in the filters from the excitation source.

Figure 7

A graph over the range of 200 nm to 600 nm showing three spectra: a) the 254 nm spectrum of a mercury discharge after transmission through a UG5 filter, b) the 365 nm spectrum of a mercury lamp after transmission through a UG5 filter, with a full width at half maximum of around 25 nm, and c) the output spectrum of a typical commercial 400 nm LED.

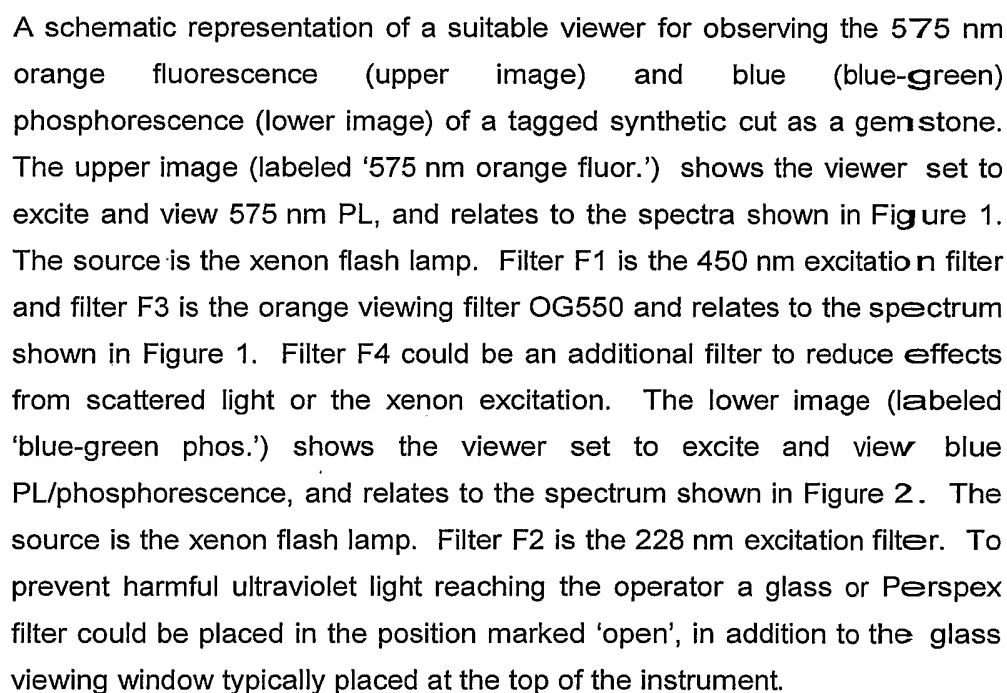
Figure 8

A graph over the range of 300 nm to 800 nm showing three spectra: a) the 575 nm PL band transmitted through an OG550 filter, extending from approximately 550 – 800 nm, b) the 400 nm LED excitation band with the transmission curve of the BG25 filter, effectively extending from 310 – 520 nm, and c) the transmission of the OG550, extending from 550 to beyond 800 nm.

Figure 9a

A schematic representation of the image provided by a layer near the culet of a round brilliant. The box in the lower left is an apparatus consisting of a ring illuminator (labeled source) positioned around a viewing window with an OG550 filter, and at the bottom of the box is positioned a CVD synthetic cut as a round brilliant with a layer tagged with the 575 nm PL centre occupying the volume from the culet to approximately 1/3 the way up the pavilion facets. The illumination is being used to solely excite 575 nm PL. The diagram above and to the right shows the image observed in such a CVD synthetic, modeled here to be 6 mm high with a 575 nm containing region/layer extending 0.8 mm (13 % the height of the stone) from the culet, when viewed normal to the table, as obtained by ray tracing. The eye (3 mm diameter pupil) of the observer is about 100 mm from the culet. The ray tracing diagram was produced by generating 4 million rays from within the 575 nm containing layer and calculating their trajectory within the CVD synthetic and their exit points. Only those rays (around 800) that entered the 3 mm aperture have been plotted on the plan view of the stone. An intense (orange, 575 nm) spot is seen in high contrast clearly evident in the

- 29 -

centre of the table, as well as a series of high intensity spots in the crown facets.

Figure 9b

A schematic representation of the image provided by a layer near the girdle of a round brilliant. The box in the lower left is an apparatus consisting of a ring illuminator (labeled source) positioned around a viewing window with an OG550 filter, and at the bottom of the box is positioned a CVD synthetic cut as a round brilliant with a layer tagged with the 575 nm PL centre occupying a thin layer near the girdle. The illumination is being used to solely excite 575 nm PL. The diagram above and to the right shows the image observed in such a CVD synthetic, modeled here to be 6 mm high with a 575 nm containing region/layer extending 0.8 mm (13 % the height of the stone) from the girdle downwards, when viewed normal to the table, as obtained by ray tracing. The details for the ray tracing are as for Figure 9a. No intense spot is seen in the table, with some general intensity visible predominantly in the table facets.

Figure 10

A schematic showing a preferred apparatus to enable an observer to see the orange/blue flash and the optical effect from an orange or blue luminescent layer in a tagged CVD synthetic.

The apparatus provides two functions. The first function comprises a long wave source that only excites the orange 575 nm PL (102, 104) and which may be an LED (102) combined with lenses and a suitable filter such as BG25 (104). The 575 nm orange PL band excited in the CVD stone is observed with high selectivity through an OG550 filter (120).

The second function comprises a short wavelength source (112, 114) that excites the phosphorescence efficiently, and which is preferably a xenon flash lamp (112) combined with suitable lenses and filters (114) to provide a source of wavelengths preferably in the range 227 nm to 254 nm. The

- 30 -

glass window (110) is provided to protect the viewer from UV radiation. In this mode of operation, the OG550 (120) is removed from the viewing path.

The complete apparatus is contained within a darkened box to allow the luminescence to be observed without interference from stray light. A viewing lens within the apparatus (118) allows the observer to see a magnified image of the stone.

Figure 11

A PL (photoluminescence) image of a 0.2 carat round brilliant CVD synthetic 10 (crown angle approximately 35 degrees to the plane of the girdle and pavilion angle 41.5 degrees to the plane of the girdle) recorded by the DiamondView™ instrument. In the original image before conversion to B/W (black and white) the areas in white are showing blue PL, and the areas in black are dark. The CVD synthetic 10 has a blue PL layer extending from the culet point to approximately 30% of the height of the stone. The image was recorded with the table facet 12 facing the viewer. The image is dominated by a distinct blue (seen here as white) 'fish-eye' spot 14 in the centre of the table facet 12. The remainder of the table facet 12 is devoid of blue PL. The crown facets 16 show a distribution of intensity from the internally scattered blue PL.

Figure 12

On the left, a computer generated image based on ray tracing techniques of the expected PL image for the round brilliant imaged in Figure 11. The side view of the modeled round brilliant (20) is shown on the right, with a PL layer 22 extending approximately 30% the height of the stone 20 from the culet point 24. As in Figure 11, the image of the PL viewed through the table facet is characterised by a 'fish-eye' spot 26 in the centre of the table facet 28, the remainder of the table facet 28 being largely devoid of PL. The crown facets 30 show a distribution of intensity from the internally scattered PL.

Figure 13

On the left, a computer generated image based on ray tracing techniques of the expected PL image for the round brilliant (40) whose side view is shown on the right. As in Figure 12, this stone is modelled with a PL layer 42 extending approximately 30% the height of the stone 40 from the culet point 44. The image of the PL viewed through the table facet is characterised by a 'fish-eye' spot 46 in the centre of the table facet 28, the remainder of the table facet 28 being largely devoid of PL. The crown facets 30 show a weak distribution of intensity from the internally scattered PL.

Figure 14

A schematic diagram of a simple layer structure which could be produced in a CVD diamond layer to provide a characteristic mark using a single type of layer with PL characteristics distinct from the bulk. The diamond material 50 includes a pair of marker layers 52,54 which show characteristic PL separated by a spacer layer 56 free of this PL characteristic and with the characteristics of the rest of the layer. The layers 52, 54 and 56 have respective thicknesses t_{m1} , t_{m2} and t_{s1} .

Figure 15

A schematic diagram of a simple layer structure which could be produced in a CVD diamond layer to provide a characteristic mark using two types of layer with PL characteristics distinct from the bulk. The diamond material 60 includes a pair of marker layers 62,64 which show similar characteristic PL separated by a layer 66 which shows PL characteristics distinct from layers 62 and 64, where all three layers 62, 64, 66 show PL characteristics distinct from those of the bulk of the material 60. The layers 62, 64, 66 have respective thicknesses t_{m1} , t_{m2} and t_{n1} .

Figure 16

A schematic diagram of a more complex layer structure which could be produced in a CVD diamond layer to provide a characteristic mark using two types of layer with PL characteristics distinct from the bulk. In

- 32 -

particular, layers 72, 76 and 80 and layers 74, 78 and 82 form two distinct groups, each group of layers having PL characteristics which are similar to each other within the group but distinct from the other group and from the bulk material 70. In addition the thicknesses of the individual layers are varied.

Figure 17

Images taken of a round brilliant cut CVD synthetic diamond using a preferred variant of the Tagging Viewer. The stone is 1.02 ct, E/F colour and VVS2 or better, the bulk of which shows uniform 575 nm PL except for a layer showing blue phosphorescence about 1/3 the way up the pavilion facets from the culet. Each image is taken looking normal to the table facet. On the left is shown the image of 575 nm PL, where the intensity in the original image before conversion to B/W (black and white) was orange and now shows as lightness or white on black. On the right is shown the image of blue phosphorescence, where the intensity in the original image before conversion to B/W was blue and now shows as lightness or white on black. The intensity in the left hand 575 nm PL image is generally relatively uniform except for a dark ring seen in the centre of the table facet. This corresponds to the bright ring seen in the table in the right hand image of blue phosphorescence. Segments of this bright ring can also be seen in the table facets

Figure 18

Images taken of a round brilliant cut CVD synthetic diamond using a preferred variant of the Tagging Viewer. The stone is 0.80 ct, F/G colour and VS1, the bulk of which shows uniform 575 nm PL except for a layer showing blue phosphorescence about 1/3 the way up the pavilion facets from the culet. Each image is taken looking normal to the table facet. On the left is shown the image of 575 nm PL, where the intensity in the original image before conversion to B/W (black and white) was orange and now shows as lightness or white on black. On the right is shown the image of blue phosphorescence, where the intensity in the original image before conversion to B/W was blue and now shows as lightness or white on black.

The intensity in the left hand 575 nm PL image is generally relatively uniform except for a dark ring seen in the centre of the table facet. This corresponds to the bright ring seen in the table in the right hand image of blue phosphorescence. Segments of this bright ring can also be seen in the table facets

Figure 19

Images taken of a square cut CVD synthetic diamond using a preferred variant of the Tagging Viewer. The stone is 0.69 ct, E/F colour and VVS2 or better, the bulk of which shows uniform 575 nm PL except for a layer showing blue phosphorescence about 1/3 the way up the pavilion facets from the culet. Each image is taken looking normal to the table facet. On the left is shown the image of 575 nm PL, where the intensity in the original image before conversion to B/W (black and white) was orange and now shows as lightness or white on black. On the right is shown the image of blue phosphorescence, where the intensity in the original image before conversion to B/W was blue and now shows as lightness or white on black.

The orange luminescence (PL), originating substantially from the 575 nm centre, extends from around 500 nm to 750 nm at room temperature. (A 575 nm PL spectrum as viewed through a band pass filter cutting off below 550 nm is shown in Figure 1). The blue PL/phosphorescence extends from 400 nm to 700 nm as shown in Figure 2. Experiments have shown that wavelengths less than about 300 nm can excite both the orange 575 nm band (Figure 3 shows the excitation spectra for the 575 nm and 637 nm bands up to the intrinsic diamond band edge (defining the diamond band gap) and is taken from Zaitsev A., *Optical Properties of Diamond: a data handbook*, Springer, 2001 (ISBN 354066582X)) and a weak blue PL/phosphorescence band. (N.B. 300 nm is outside the spectral response of the eye).

Wavelengths between 227 nm and about 254 nm are most efficient at exciting blue PL/phosphorescence from within the volume of the diamond. It is important to note that excitation at wavelengths less than 227 nm will

- 34 -

be substantially absorbed at the surface of the diamond and will only generate luminescence at the surface. (This is the method employed in the DiamondView™ instrument. While this would be useful for looking at tagging layers at the surface, if they are covered by a jewellery setting where they come to the surface, then a surface excitation method using wavelengths less than 227 nm is inappropriate). Since the orange 575 nm PL turns off with the excitation source, the perceived colour of the PL from the CVD diamond material, or the coloured layers within it, would change from orange, or some orange/blue combination, to blue (the orange/blue flash). The visibility of such a change in colour, particularly the visibility of the orange component against the blue phosphorescence, may need to be enhanced by use of suitable filters.

Examples of apparatus that can be used to excite and detect the orange/blue flash effect from 575 nm and or the optical effect from a single layer are set out below.

Apparatus Example 1: Filtered xenon flash lamp excitation

The apparatus required to observe the orange/blue flash effect could consist of a single excitation source such as a xenon flash lamp. To reduce the cost of the tagging viewer a low power xenon flash lamp is suggested, although this does not exclude the use of a more powerful xenon flash lamp. The frequency of the PL would follow the flash lamp excitation frequency. As the PL, and possibly a component of the direct excitation, would be viewed by an observer, the choice of repetition frequency is important. Some low power xenon flash lamps will only deliver full power at a repetition rate of about 10 Hertz. These are best avoided on grounds of safety as it is known that flashing light can trigger epileptic seizure in susceptible individuals. The frequency of flashing light that is most likely to trigger a seizure varies from person to person but is generally between 5 and 30 Hertz. A suitable source could be a 5 Watt xenon flash lamp from Hamamatsu Photonics, type L9456, operating at a peak power flash repetition rate of about 126 Hertz.

- 35 -

The main curve extending across the plot in Figure 4 shows the emission spectrum of a Hamamatsu Xenon flash lamp. The radiation from the xenon flash lamp is dominated by intense visible emission bands in the long wave range 400 nm to 550 nm and very intense short wave ultraviolet emission bands in the range 220 nm to 270 nm. These long wave and short wave bands conveniently cover the wavelengths of excitation for the 575 nm and blue bands respectively. A suitable off-the-shelf filter in combination with a xenon flash lamp for exciting only 575 nm PL (and no blue phosphorescence) could be a narrow bandpass filter supplied by LOT Oriel, UK and manufactured by Andover Corporation, USA, type 450 FS 40-25, with a peak wavelength centred at 450 nm, full bandwidth at half maximum of about 40 nm and diameter of 25 mm (see Figure 4). This wavelength band is within the vibronic absorption band of the 575 nm centre. This excitation is also within the vibronic absorption band of the 637 nm centre (see Figure 3). If present the 637 nm luminescence would also usefully be excited with the 575 nm luminescence. In order to view the 575 nm luminescence the 450 nm visible excitation must be blocked. This may be carried out effectively with an OG550 glass filter from Comar Instruments, UK. Figure 1 shows three curves, the curve centred about 450 nm which is the excitation beam generated by the Xenon flash lamp after filtering by the Andover 450 nm filter described above, the rising edge of the band pass region of the OG 550 viewing filter at about 550 nm, used to remove any of the excitation frequencies from the viewed image, and the emission spectrum of the 575 nm PL centre as viewed through the OG550 filter.

A suitable off-the-shelf filter in combination with a xenon flash lamp for exciting blue luminescence/phosphorescence could be a narrow bandpass filter supplied by LOT Oriel, UK and manufactured by Andover Corporation, USA, type 228 FS 25-25, with a peak wavelength centred at 228 nm, full bandwidth at half maximum of about 25 nm and diameter of 25 mm or a similar filter type 232 FS 25-25 with a peak wavelength centred at 232 nm and full bandwidth at half maximum of about 25 nm. Figure 2 shows two curves, the curve centred about 228 nm which is the excitation beam

- 36 -

generated by the Xenon flash lamp after filtering by the Andover 228 nm filter and the emission spectrum of the blue PL/phosphorescence centre. As the excitation does not lie in the visible spectrum no visible blocking filter is required to observe the resulting luminescence and especially not the phosphorescence when the source is switched off. However, direct viewing of short wave ultraviolet light is extremely harmful to the eyes and must be avoided. Use should be made of a glass or Perspex-type window to block all harmful ultraviolet light from the observer but allow unimpeded observation of the PL/phosphorescence.

The apparatus described in this example is shown schematically in Figures 5 and 6. The apparatus labeled '575 nm orange fluor.' shows the viewer set to excite and view 575 nm PL, and relates to the spectra shown in Figure 1 and described above. The source is the xenon flash lamp. Filter F1 is the 450 nm excitation filter and filter F3 is the orange viewing filter OG550 and relates to the spectrum shown in Figure 1 and described above. Filter F4 could be an additional filter to reduce effects from scattered light or the xenon excitation. The apparatus labeled 'blue-green phos.' shows the viewer set to excite and view blue PL/phosphorescence, and relates to the spectrum shown in Figure 2 and described above. The source is the xenon flash lamp. Filter F2 is the 228 nm excitation filter. To prevent harmful ultraviolet light reaching the operator a glass or Perspex filter could be placed in the position marked 'open'. Figure 6 shows the apparatus in side elevation. The viewing filters are placed at approximately 45 degrees from the vertical and set away from direct excitation to prevent the operator viewing the source directly and to eliminate the production of luminescence in the filters from the excitation source. Note that the loose stone under test in figures 5 and 6 has been oriented roughly with its table facing the excitation source with the observer viewing the stone from the pavilion. In this example provided the stone is fully illuminated the orientation of the stone is unimportant.

Apparatus Example 2: Gas discharge lamp excitation

- 37 -

As previously mentioned, 575 nm luminescence may be excited in the absence of blue luminescence by wavelengths in the range about 300 nm to 575 nm (see Figure 3). Bulk blue phosphorescence may be excited by wavelengths in the range 227 nm to 300 nm, but wavelengths in the range 227 nm to 254 nm are more efficient.

An alternative to using a filtered broadband source to stimulate the respective excitation bands is to employ a dual wavelength laser excitation. However, in order to remove the necessity for laser safety requirements and to reduce the component costs of the tagging viewer the emission from low pressure gas discharge lamps can be used. In particular the 254 nm (short wave) and 365 nm (long wave) emissions from the mercury discharge lamp can be employed. Mercury long wave and short wave excitations are used commonly for the observation of luminescence from minerals, including diamond. The unique aspect of the present method, as discussed above, is to use the 365 nm excitation first to excite exclusively 575 nm luminescence and then the 254 nm excitation to excite the blue phosphorescence. The intense 254 nm line is the dominant emission from low pressure mercury discharge lamps although there are other minor discharge lines (e.g. 365 nm) and broad background discharge in the visible. To minimize the effect of the visible discharge on the observation of PL in minerals etc the manufacturers of mercury discharge lamps fit a UG5 type filter in front of the lamp. The UG5 filter transmits below 420 nm and above 650 nm. The 254 nm spectrum in Figure 7 is the mercury discharge through a UG5 filter. The 365 nm emission lamp is not purely the result of a mercury discharge. It is produced by the 254 nm discharge exciting luminescence from a phosphor coating on the interior wall of the tube. The 365 nm spectrum is a band with a full width at half maximum of around 25 nm (see Figure 7). This is very efficient at exciting 575 nm luminescence but does not excite 637 nm emission from diamond.

Thus, in accordance with the proposed method, the 365 nm source is first switched on to excite 575 nm PL in the CVD synthetic. Viewing the 575 nm PL through an OG550 filter is an advantage as the filter removes

- 38 -

substantially all of the background discharge from the 365 nm mercury lamp. The 365 nm lamp should then be switched off and the 254 nm lamp switched on. (The action of switching on the 254 nm lamp could usefully automatically switch off the 365 nm lamp). After several seconds the 254 nm lamp should be switched off and the presence of blue phosphorescence noted.

This method could be embodied in the apparatus shown in Figures 5 and 6, the xenon flash lamp being replaced by the 254 nm and 365 nm mercury lamps. It has been found that mercury discharge lamps can be arranged above the sample under test. In this way a bank of 2, 3, 4, 5 or more 254 nm and 365 nm lamps may be mounted together to increase the radiation intensity on the sample. Discharge lamps may be formed into any shape and could be formed in such a way as to allow circular illumination of the sample allowing almost direct close proximity excitation from above. The sample could be viewed through the ring illumination. Suitably intense miniature Pen-Ray® lamps supplied by Ultra-Violet Products (UVP) USA could be used which would also make the apparatus extremely compact. However any gas discharge lamp capable of producing sufficiently intense excitation in the ranges 300 nm to about 500 nm (for 575 nm PL) and 227 nm to about 254 nm (for blue PL/phosphorescence) would be suitable. Note that, just as in Apparatus Example 1 the loose stone under test in figures 5 and 6 has been oriented roughly with its table facing the excitation source with the observer viewing the stone from the pavilion. In the present example provided the stone is fully illuminated the orientation of the stone is unimportant.

Apparatus Example 3: Combination of light emitting diode (LED) and mercury discharge lamp excitations

As previously mentioned, 575 nm luminescence may be excited in the absence of blue luminescence by wavelengths in the range about 300 nm to 575 nm (see Figure 3). Bulk blue phosphorescence may be excited by

- 39 -

wavelengths in the range 227 nm to 300 nm, but wavelengths in the range 227 nm to 254 nm are more efficient.

In accordance with the proposed method, the long wave source that only excites the orange 575 nm PL could be a light emitting diode (LED). A suitable LED emitting an emission band centred at 400 nm is shown in Figure 7. The total optical power output from this type of LED is approximately 1-2 mW. Higher power LEDs are available from, for example, Nichia Corporation, Japan. Further examples are the 365 nm, 375 nm and 380 nm UV LEDs from Nichia or the Luxeon Lumiled Star/C royal blue (455 nm) LED. Extreme caution must be observed to protect the observer from the intense UV radiation from these sources. The optical emission from some of these LEDs can exceed 100 mW.

Provided the viewing filter (for example OG550 or OG570) can block the excitation wavelengths any LED in the range 300 nm to approximately 500 nm is suitable. Experiments have shown that an effective means of ensuring minimal overlap of the excitation wavelengths with the PL emission wavelengths is to use a short wavelength pass filter to block any long wavelength tail of the excitation. By way of example when using the 365 nm UV LED an effective blocking filter is a UG11 or a BG25. When using the 375 nm, 380 nm, 400 nm UV LEDs or 455 nm LED an effective blocking filter is a BG25. By way of example when the BG25 and OG550 are both placed over the UV LED almost total blocking of the LED emission is obtained. Any minor bleed-through from the BG25 can be avoided by any geometric arrangement that avoids the observer looking directly at the excitation source through the OG550 filter when observing the PL from the sample. By way of example Figure 8 shows the 400 nm LED excitation band with the transmission curve of the BG25 filter effectively extending from 310 – 520 nm. The BG25 effectively blocks background emission from the LED above 520 nm. The 575 nm PL band transmitted through an OG550 filter is shown extending from 550 – 800 nm, and for completeness the transmission of the OG550 is shown from 550 – 800 nm. As the long wavelength tail of the excitation from the 400 nm LED at 700 nm is less

- 40 -

than 0.01% of its peak intensity at 400 nm then any minor bleed-through transmission from the BG25 between 700 – 800 nm is not significant.

Thus the use of, for example, a 400 nm UV LED and BG25 blocking filter to excite 575 nm PL and the use of an OG550 to view the 575 nm PL is a useful method in its self to identify CVD synthesized diamond exhibiting 575 nm PL.

With this configuration the LED is first switched on to excite 575 nm PL in the CVD synthetic diamond material. Viewing the 575 nm PL through an OG550 filter is an advantage as the filter removes substantially all of the long wavelength tail of the LED excitation. The LED should then be switched off and a 254 nm mercury discharge lamp switched on. (The action of switching on the 254 nm lamp could usefully automatically switch off the LED). After several seconds the 254 nm lamp should be switched off and the presence of blue phosphorescence noted.

This method could be embodied in the apparatus shown in Figures 5 and 6, the xenon flash lamp being replaced by the 254 nm mercury discharge lamp and LED. It has been found that mercury discharge lamps and LEDs can be arranged above the sample under test. In this way a bank of 2, 3, 4, 5 or more 254 nm lamps and a bank of 2, 3, 4, 5 or more LEDs may be mounted together to increase the radiation intensity on the sample. In the same way as the mercury discharge lamp may be formed into a circular illuminator, so too could a bank of LEDs be arranged in the form of a ring illuminator which could be concentric with the mercury discharge illuminator. This arrangement would make the apparatus extremely compact. Note that, just as in Apparatus Examples 1 and 2 the loose stone under test in figures 5 and 6 has been oriented roughly with its table facing the excitation source with the observer viewing the stone from the pavilion. In the present example provided the stone is fully illuminated the orientation of the stone is unimportant.

Apparatus Example 4: Optical effect from luminescent layer

- 41 -

The tagging layer should be positioned so that in any mount not normally easily removed, such as a jewellery setting, the volume of the layer can be efficiently excited by an external light source used during identification, the key point being that this light distribution may differ from that in normal viewing conditions, being for example a high intensity parallel beam rather than a more diffuse light source. Another example may be a high intensity ring illuminator placed over the sample. The interaction between the light source and the target cut stone is sensitive to the geometry or cut of the stone, and for precise analysis needs advanced ray tracing calculations. More importantly, the interaction between the luminescence or phosphorescence emitted by a layer or region within the cut stone and the cut of that stone, which forms the pattern of rays seen by the observer is sensitive to the geometry or cut of the stone, and the position of the layer or region within it, and for precise analysis needs advanced ray tracing calculations. Such ray tracing calculations have been carried out.

Considering a nitrogen doped layer (containing 575 nm / 637 nm centres) extending about 13% of the height of the stone from the culet/point of the stone, the efficient excitation of the layer may require careful control of the excitation beam angle but this positioning of the layer may then be more effective in providing emission of internal luminescence directly out through the table.

Figure 9a (lower left) shows an apparatus consisting of a ring illuminator with excitation near the normal of the table of the stone. The illumination is being used to solely excite 575 nm PL. The illumination could be a 365 nm mercury discharge lamp, a filtered xenon flash lamp, a 365 nm, 375 nm, 380 nm, 400 nm or 455 nm LED or any suitably filtered intense source that excites 575 nm PL. The ray tracing diagram in Figure 9a has been produced from a CVD synthetic 6 mm high with a 575 nm containing region/layer extending 0.8 mm (13 % the height of the stone) from the culet. The eye (3 mm diameter pupil) of the observer is about 100 mm from the culet. The ray tracing diagram was produced by generating 4 million rays

- 42 -

from within the 575 nm containing layer and calculating their trajectory within the CVD synthetic and their exit points. Only those rays (around 800) that entered the 3 mm aperture have been plotted on the plan view of the stone. An orange spot is seen in high contrast clearly evident in the centre of the table. The rays responsible for this spot exited the stone within the 22.4 degrees critical angle and therefore without internal reflection. Rays from the layer incident on the table facet outside the critical angle undergo internal reflection and exit at the crown facets with a distribution shown in Figure 9a. This production of a coloured (in this case orange) spot is likely to be unique to a CVD synthetic with a well defined volume or layer producing luminescence or phosphorescence (in this case a nitrogen doped layer producing 575 nm PL) placed near the culet.

Figure 10 shows a preferred apparatus 100 to enable an observer to see the orange/blue flash and the optical effect from an orange or blue luminescent layer in a tagged CVD synthetic. As previously mentioned, bulk 575 nm luminescence may be excited in the absence of blue PL/phosphorescence by wavelengths in the range about 300 nm to 575 nm (see Figure 3). In accordance with the preferred apparatus 100, the long wave source 102 that only excites the orange 575 nm PL could be a Luxeon Lumiled Star/C royal blue light emitting diode (LED) emitting about 150 mW of optical radiation at 455 nm. When using the 455 nm LED an effective blocking filter 104 to prevent the observer seeing the excitation radiation is BG25. The BG25 filter effectively blocks light above 520 nm. The 575 nm orange PL band excited in the CVD stone 106, mounted in a ring/stone mount 108, by the 455 nm LED is observed with high purity through an OG550 filter 110.

As previously mentioned, bulk blue phosphorescence may be excited by wavelengths in the range 227 nm to 300 nm, but wavelengths in the range 227 nm to 254 nm are more efficient. In accordance with the preferred apparatus, the short wave source 112 that excites the blue PL /phosphorescence is a 5 Watt xenon flash lamp from Hamamatsu Photonics, type L9456-01, operating at a peak power flash repetition rate of

- 43 -

126 Hertz. A suitable off-the-shelf filter 114 for transmitting only the deep UV excitation from the lamp (and exciting the blue luminescence/phosphorescence) is the type 232 FS 25-25 narrow bandpass filter supplied by LOT Oriel, UK and manufactured by Andover Corporation, USA, with a peak wavelength centred at 232 nm and full bandwidth at half maximum of about 25 nm.

The complete apparatus is contained within a darkened box 116 to allow the luminescence to be observed without interference from stray light. A viewing lens 118 within the apparatus allows the observer to see a magnified image (x2.5 for example) of the stone. The viewer was designed for use in a retail environment so great care was taken to protect the observer from harmful UV using a glass or Perspex viewing window 120 located below a viewing visor 122. The tagging viewer was also designed to sit on a microscope stage (not shown), and the fine spatial distribution of the luminescence/phosphorescence emitted by the diamond material or body under test was easily discernable and recorded with a digital camera.

With this configuration the LED is first switched on by continually depressing the LED 102 button to excite 575 nm/orange PL in the CVD synthetic 106. The orange PL is observed through the OG550 filter 110. If there is a nitrogen doped layer producing 575 nm PL below the girdle of the stone then the observer will see a distinctive orange ring or spot in the centre of the table facet as illustrated by the ray trace diagram in Figure 9a. This production of an orange spot is likely to be unique to a CVD synthetic. When the LED 102 button is released the orange PL ceases. The OG550 filter 110 is then manually removed. The xenon flash lamp 112 is then switched on by continually depressing the UV lamp button. The observer will then see a blue PL image of the CVD synthetic 106 with possibly some orange PL. When the UV button is released the observer will see blue phosphorescence. If there is a boron doped layer below the girdle of the stone then the observer will see a distinctive blue ring or spot in the centre of the table facet in both PL and phosphorescence as illustrated by the ray

- 44 -

trace diagram in Figure 9a. This production of a blue spot is likely to be unique to a CVD synthetic.

An alternative to a layer forming a portion of the cut stone up from the culet to a single boundary, is a discrete layer. Using the apparatus just described, shown in Figure 17 are two images of a single tagged CVD synthetic polished into a 0.80 carat round brilliant. The bulk of the stone was grown with nitrogen. Under 455 nm LED excitation the bulk of the stone produces orange 575 nm PL as shown in the image on the left of Figure 17. In order to produce an image of a discrete layer clearly visible in the table of the cut stone, a preferred layer was positioned well below the girdle, (typically) about $\frac{1}{4}$ - $\frac{1}{3}$ up the height of the cut stone. Thus the stone in Figure 17 has a boron doped layer phosphorescent, around 200-300 μm thick, at this position. This discrete layer only produces very weak 575 nm PL and therefore provides a reasonably well defined dark ring which is visible when viewing the 575 nm PL produced through the table. However, when the LED is switched off and the xenon flash lamp switched on, the dark ring corresponding to the boron doped layer, is rendered highly visible as a well defined intense blue PL/phosphorescence ring viewed through the table as seen in the right hand image in Figure 17.

Additional images of segments of this ring may be visible in the crown facets, dependent on the exact orientation of the facets, with the position of the segment of the ring being similar in each facet of the same type and angle, but varying between the facets of different type and angle, to provide a complex series of features reflecting the symmetry of the stone. The production of a well defined coloured ring (in this case a blue ring) viewed within the table is likely to be unique to a CVD synthetic with a well defined volume or layer producing luminescence or phosphorescence (in this case a boron doped layer) placed in the lower half of the cut stone, below and away from the girdle. Indeed, this case is clearly represented by the right hand image of the example stone in Figure 17.

- 45 -

Figure 9b shows a ray tracing diagram for a stone with, for example, a 575 nm PL layer just below the girdle. The effect this time is to produce a well defined orange ring just outside the table facet of the CVD synthetic. Similarly, the production of a well defined coloured ring (in this case an orange ring) is likely to be unique to a CVD synthetic with a well defined volume or layer producing luminescence or phosphorescence (in this case a nitrogen doped layer producing 575 nm PL) placed just under the girdle. Those skilled in the art will understand that a range of other positions of the layer are possible, with the perceived pattern encompassing a variety of rings and other identifying patterns, but that the key feature is that the non-natural distribution of optical centres in the cut diamond is detectable as a non-natural pattern of colour in the viewed stone, preferably viewed from the table, under suitable conditions.

By way of further example Figure 11 shows a PL image of a 0.2 carat round brilliant CVD synthetic 10 (crown angle approximately 35 degrees to the plane of the girdle and pavilion angle 41.5 degrees to the plane of the girdle) recorded by the DiamondView™ instrument. The CVD synthetic 10 has a blue PL layer extending from the culet point to approximately 30% of the height of the stone. The image was recorded with the table facet 12 facing the viewer. The DiamondView™ excitation is sufficiently penetrating in a type II CVD synthetic to excite substantial sub-surface PL. The image of the blue PL layer in the DiamondView™ is very similar to that observed simply by eye with bulk excitation of the stone with short wave UV light with wavelengths in the range 227 nm to approximately 254 nm. The image is dominated by a distinct blue 'fish-eye' spot 14 in the centre of the table facet 12. The remainder of the table facet 12 is devoid of blue PL. The crown facets 16 show a distribution of intensity from the internally scattered blue PL.

Figure 11 compares very well with an image from a stone 20, with similar geometry, generated using the ray tracing programme for a PL layer 22 extending approximately 30% the height of the stone 20 from the culet point 24, shown in Figure 12. Like Figure 11, Figure 12 is also characterized by

- 46 -

a 'fish-eye' spot 26 in the centre of the table facet 28, the remainder of the table facet 28 being devoid of PL. As in the case of the DiamondView™ image and Tagging viewer image, the crown facets 30 show a distribution of intensity from the internally scattered PL.

It should be noted that the stone 10 used in Figure 11 and the stone used in Figure 17 also have an orange 575 nm layer above the blue PL layer. Thus these stones will also perfectly demonstrate the orange/blue flash effect in the DiamondView™ and the Tagging viewer and using the methods described above.

There is an effect on the observed image from a variation in the pavilion angle. However, the resulting images are sufficiently well defined to provide great confidence in the use of the optical effect from luminescent layers for stones of varying pavilion and crown angles and stone shapes such as square cut or emerald cut. The effect on the PL image of changing the pavilion angle in a round brilliant stone from 41.5 degrees (Figure 12) to 25 degrees in a stone 40 is shown in Figure 13. The characteristic 'fish-eye' 42 is clearly visible and therefore identifies the stone as a tagged CVD synthetic.

Particularly in the case where the layers are intended to form a unique signature representing the manufacturer or other information, rather than just provide evidence of the synthetic nature of the material, then consideration needs to be given to the structural sequence of the layers. The characteristic pattern of lines forming a tag within a cut CVD synthetic stone needs to be as widely applicable as possible, and potentially could be used in CVD diamond layers which are themselves boron doped to provide a visible blue colour, but also providing a source of blue-band phosphorescence, or in CVD diamond layers or objects which otherwise contain nitrogen and thus show orange luminescence through part or the whole of their volume. By combining the two layers together into a pattern, the same pattern can then be observed and identified in both these types of CVD diamond layer or object, with the risk that final layers at the edge of

- 47 -

the mark may blend into the background. This risk is minimised by using an asymmetric mark, where one edge of the mark is defined by blue phosphorescence and the other is defined by orange luminescence. Alternatively some neutral background could be used around the mark, or the mark could be deliberately varied at the pattern edges to provide clarity in any particular type of stone

In CVD diamond layers with a sufficiently high level of boron more generally present through the volume, for example where a strongly coloured stone is required, then the addition of nitrogen in marker layers may not be sufficient to generate orange luminescence but may merely modulate the blue phosphorescence from donor-acceptor pair recombination. One solution is to specifically reduce the B concentration in the N doped layers to enable the orange luminescence to be observed. Alternatively, under such circumstances the modulation of the blue phosphorescence may be sufficient, and can be controlled by both the added N and added B concentrations.

Likewise, in a process where nitrogen is added for other reasons and 575 nm PL is present throughout the layer, an alternative to producing 575 nm luminescing layers is to produce layers free of 575 nm luminescence, or to modulate the intensity of the 575 nm luminescence by varying the nitrogen concentration or by other process variations such as the methane concentration or the temperature.

There are further advantages to the choice of marker layers, in that the blue phosphorescence of the boron is stable with respect to post treatments such as annealing, so that these marks would remain even if the CVD diamond layer, object or synthetic gemstone was treated by such means. Conversely the orange luminescence is modified by annealing, particularly at very high temperatures. These lines would therefore indicate that the object had been post treated after the point of sale. In particular, annealing of the orange luminescence can convert the orange luminescence to a characteristic green luminescence or phosphorescence (the extent to which

- 48 -

this light continues to be emitted after the removal of the excitation source varying over several orders of magnitude depending on the relative concentration of the defects involved). The stability of the layers showing blue phosphorescence thus enables the location of the previously orange luminescing bands to be determined and the treatment conditions to be determined from the modified, increased or reduced colour then present in these bands.

As will be described in the example sections, a distinctive orange/blue flash is observed from tagged CVD synthetics under suitable illumination conditions. In annealed tagged CVD synthetics (particularly those annealed at very high temperatures) the orange/blue flash may be replaced with a green/blue flash. This effect would be noticeable, by a suitably trained individual, from a tagged CVD synthetic cut into any shaped brilliant e.g. round or square.

As described earlier and further described by the examples, a distinctive orange/blue 'fish-eye' ring or spot is observed from suitably tagged CVD synthetics under suitable illumination conditions. As the blue phosphorescence of the boron doped CVD diamond is stable with respect to post treatments, such as annealing, the blue 'fish-eye' ring (picture-frame in square cut stones) or spot remains unaltered and is still an effective means of identifying a tagged CVD synthetic stone even after annealing in both round cut and square cut stones.

A particular variant of the invention is the deliberate use of the green luminescence obtained after annealing orange luminescing material, either in isolation or in combination with other tagging centres and structures.

The simplest pattern of multiple lines envisaged using one type of marker layer (e.g blue phosphorescence) is shown in Figure 14. The diamond material 50 includes a pair of marker layers 52,54 separated by a spacer layer 56.

Here, t_m is the thickness of the respective marker layers 52,54 and t_s is the thickness of the spacer layer 56.

Adding in a second type of layer (e.g. orange luminescence) gives a structure as shown in Figure 15. In this embodiment, the synthetic diamond material 60 has a pair of first marker layers 62,64 separated by a second marker layer 66. A simpler structure which may be more appropriate in some circumstances is one layer of each of the two types of marker layer placed adjacent to one another, with a further variant being where these two layers are spaced apart by a spacer layer of undoped or untagged material.

In particularly preferred embodiments, it is envisaged that the structures would probably be more complex, using more layers and with clearly varying thicknesses. In the synthetic diamond material 70 shown in Figure 16, the thicknesses of the layers 72, 74, 76, 78, 80 and 82 are varied. They may be, for example, 50 μm (74,80), 25 μm (76,78), and 12 μm (72,82), giving a total thickness of the mark of 175 μm , which would be clearly visible under the correct viewing illumination provided that the dopant levels were suitably controlled.

It has been demonstrated that the marker layers of given thicknesses can be grown to an accuracy of 10% or better, with typical values being in the 3%-5% region. For thicker layers or in a routine production process it may be possible to achieve an accuracy of 2% or better. However, when viewing the layers with above band-gap illumination, the marker layers will be seen on any surface which intersects those layers, but that surface may not be normal (i.e. at right angles) to the marker layers, and in many commercial diamond objects including synthetic gemstones this will often be the case. Thus, the absolute dimensions of the layers will typically not be consistent from one facet of a CVD diamond object to another, or necessarily between similar objects (although this may be the case if both the marker layers and the orientation of the object cut out of the diamond are crystallographically oriented), easily varying by up to about +/-50%

- 50 -

depending on the angle of the facet on which they are viewed. What will be consistent across any single facet, however, is the relative ratios of the thicknesses of the layers and the sequence of colours, which will allow for proper identification of the mark of origin or fingerprint. It is of course possible from the geometry of the CVD diamond object and the specific orientations of the layer(s) and the facet intersected, to calculate the precise thicknesses of the layers, but this is a level of complexity which the preferred embodiment avoids. It may also be possible to measure these thicknesses directly using techniques such as confocal depth profiling, but again this generally needs more complex equipment than is desirable.

Thus, taking relative ratios of the thicknesses of layers as the only measurable characteristic, a single marker layer gives no information, since there is no reference point. However, a mark of origin with 2 marker layers and a spacer layer gives two unique parameters, for example taking the spacer layer as the scale bar against which to compare the thickness of each of the marker layers. A mark of origin with 3 marker layers and 2 spacer layers gives 4 unique parameters (provided there is no mirror symmetry), etc. Hence, in practice, it is believed that the reasonable number of layers to provide a distinguishable mark of origin but permitting several deliberate variants would be three marker layers, giving 4 unique thickness ratio parameters. In the case where 2 distinct type of marker layers are used alternately, the number of unique parameters can be considered in a similar fashion.

By way of example the invention is described above giving detail of specific detail of optical centres and layered structures which are advantageous. However, those skilled in the art will understand that this does not limit the generality of the invention, which in its most general form provides a means of detecting the synthetic nature of a diamond layer without affecting its visual properties under normal viewing conditions. A preferred form is the use of optical centres such as the 575 nm PL centre to provide the synthetic indicators. However, it may be possible to use other features or properties of the material. A further preferred form is the use of layered

- 51 -

structures to emphasise the deliberate synthetic nature of the material. A particularly preferred form is the combination of the use of optical centres and layered structures to provide clear evidence of the synthetic nature of the material even where access or other considerations may add difficulties.

The invention will now be described with reference to the following non-limiting Examples.

EXAMPLE 1

Substrates suitable for synthesising single crystal CVD diamond were prepared according to the method described in WO 01/96634, with {100} major faces.

These substrates were brazed onto a tungsten substrate using a high temperature diamond braze. This was introduced into a microwave plasma CVD reactor and an etch and growth cycle commenced in the general form described in WO 01/96634, and then synthesis proceeded as follows:

The first stage of growth comprised 200/250/4500 sccm (standard cubic centimetre per second) of CH₄/Ar/H₂ at 200 x 10² Pa and a substrate temperature of 850°C with no added dopants.

The second stage of growth was the same as the first stage above with the addition of 0.8 sccm of 20 ppm B₂H₆ diluted in hydrogen (0.003 ppm), and the addition of 25 sccm of 100 ppm N₂ diluted in hydrogen (0.5 ppm).

The third stage of growth was the same as the first stage above with the addition of 10 sccm of 100 ppm N₂ diluted in hydrogen (0.2 ppm).

The fourth stage was a repeat of the first stage.

- 52 -

On completion of the growth period, the substrate was removed from the reactor and the CVD diamond layer removed from the substrate. This layer was then polished to produce a 6.7 x 6.6 x 2.3 mm diamond block of {100} growth sector material and analysed for its optical properties and the structure of the layers.

Using above bandgap radiation in a 'DiamondView™' the structure of the layers was determined by viewing a side face of the block to be: layer 1: 450 µm thick, layer 2: 250 µm thick, layer 3: 285 µm thick and layer 4: 1.31 mm. Layer 2 showed strong phosphorescence and layer 3 showed strong 575 nm luminescence. This layer structure is unique to synthetic diamond of this invention

Under a standard jewelers UV hand lamp it was possible to discern luminescence and phosphorescence from the stone in a darkened room, although the blue phosphorescence tended to dominate the orange luminescence during exposure.

A low cost viewer suitable for volume production was constructed to evaluate the phosphorescence and luminescence properties of the diamond described in detail in Apparatus Example 4 and illustrated in Figure 10. The viewer comprised a 5 W OEM pulsed Xenon unit (Hamamatsu Photonics, type L9456) and a Luxeon Lumiled Star/C LED emitting at 455 nm.

A 0.2 ct round brilliant cut synthetic was produced from a similar block of CVD diamond produced in the same synthesis run and was graded to be H colour. The first layer, below the boron phosphorescent layers, was removed during processing. The appearance of the 575 nm luminescence and blue phosphorescence observed in this stone when viewed through the table in DiamondView™ and Tagging viewer was described earlier (Figure 11 and Figure 12), with a distinct blue 'fish-eye' spot visible in the centre of

- 53 -

the table surrounded by orange luminescence, and a distinct pattern of blue phosphorescence and orange luminescence visible in the crown facets.

EXAMPLE 2

The growth procedure described in Example 1 was repeated to produce a layer 5 x 5 x 3 mm thick.

Vertical plates were cut out of this block and fabricated into diamond scalpel blades. The presence of the tagging layers was not discernable under normal illumination in these blades and did not affect their normal function.

Upon inspection using DiamondView™, the presence and structure of the tagging layers was clearly discernible, identifying the origin of the material from which the blades were fabricated.

Inspection under the low cost viewer described in Apparatus Example 4, and Example 1 and illustrated in Figure 10 clearly showed orange luminescence and blue phosphorescence, making clear the unique synthetic nature of the material.

EXAMPLE 3

The growth procedure described in Example 1 was repeated to produce a layer 3.7 mm thick. This layer was polished into a round brilliant cut.

Upon inspection using DiamondView™, the presence and structure of the tagging layers was clearly discernible, cutting across the facets just below the girdle, identifying the origin of the material from which the stone was produced.

Inspection under the low cost Tagging viewer described in Example 1, Apparatus Example 4 and illustrated in Figure 10 clearly showed orange

- 54 -

luminescence and blue phosphorescence, making clear the unique synthetic nature of the material.

EXAMPLE 4

Using growth conditions similar to Example 1, but varying the duration of the different layers, a series of demonstrator stones in the form of round brilliants and square cut stones have been produced. The demonstrator stone images are shown in Figures 17 to 19. The left hand image in each figure is the image of the stone under 455 nm LED excitation and showing 575 nm/orange PL. The right hand image in each figure is the image of the stone under 232 nm deep UV excitation from the filtered xenon flash lamp and shows the blue PL/phosphorescence. Figures 17 and 18 show round brilliant demonstrator stones and Figure 19 shows a square cut demonstrator stone.

CLAIMS

1. A method of incorporating a mark of origin or fingerprint in a CVD single crystal diamond material, which includes the steps of providing a diamond substrate, providing a source gas, dissociating the source gas thereby allowing homoepitaxial diamond growth, and introducing in a controlled manner one or more chemical dopants into the synthesis process in order to produce the mark of origin or fingerprint in the synthetic diamond material, which dopant is selected such that the mark of origin or fingerprint is not readily detectable or does not affect the perceived quality of the diamond material under normal viewing conditions, but which mark of origin or fingerprint is detectable or rendered detectable under specialised viewing conditions.
2. A method according to claim 1, wherein the mark of origin or fingerprint is detectable or rendered detectable when the diamond material is exposed to light or radiation of a specified wavelength.
3. A method according to claim 1 or claim 2, wherein the mark of origin or fingerprint is provided in the form of one or more layers or regions grown into the diamond material during synthesis.
4. A method according to any one of the preceding claims, wherein the one or more chemical dopants introduced into the synthesis process are added in a gaseous form.
5. A method according to any one of the preceding claims, wherein the chemical dopant, or one of the dopants, provides a source of nitrogen which is incorporated into the diamond, and which produces a mark of origin or fingerprint that shows 575 nm and/or 637 nm luminescence peaks, with their associated vibronic systems, under suitable shorter wavelength excitation.

- 56 -

6. A method according to claim 5, wherein the mark of origin or fingerprint shows a photoluminescence line at 533 nm.
7. A method according to any one of claims 1 to 4, wherein the dopant or dopants provide(s) a source of boron and a source of nitrogen, which elements are incorporated into one or more specific regions of the diamond and which produce a mark of origin or fingerprint that generates characteristic phosphorescence, peaking generally in the range of 400 nm to 500 nm, under suitable shorter wavelength excitation.
8. A method according to claim 7, wherein the boron is incorporated into the synthesized diamond material in a concentration less than 0.1 ppm.
9. A method according to claim 7 or claim 8, wherein the boron is incorporated into the synthesized diamond material in a concentration greater than 0.0001 ppm.
10. A method according to any one of claims 7 to 9, wherein the concentrations of boron and nitrogen incorporated into the synthesized diamond material lie within a factor of 10 of one another.
11. A method according to any one of claim 7 to 10, wherein the boron is present in the synthesized diamond material in a higher concentration than the nitrogen.
12. A method according to any one of the preceding claims, wherein a combination of layers or regions that generate 575/637 nm luminescence and 400 nm to 500 nm phosphorescence under suitable optical wavelength excitation is grown into the diamond material during synthesis.

- 57 -

13. A method according to any one of the preceding claims, wherein a layer or region with a centre that emits 737 nm radiation under optical excitation is grown into the diamond material during synthesis.
14. A method according to claim 13, wherein the one or more dopants include a source of silicon.
15. A method according to claim 14, wherein the silicon is incorporated into the synthesized diamond material in a concentration less than 10 ppm.
16. A method according to claim 14 or claim 15, wherein the silicon is incorporated into the synthesized diamond material in a concentration greater than 0.0001 ppm.
17. A method according to any one of claims 1 to 12, wherein the detection of the mark of origin or fingerprint is by the human eye, in combination with other suitable optical elements including filters and lenses.
18. A method according to any one of claims 1 to 16, wherein the detection of the radiation is by an instrument providing a measure of the intensity of the radiation, or providing an indication whether this value lies above or below a threshold.
19. A method according to claim 18, wherein the radiation being detected is the 737 nm radiation.
20. A method according to any one of claims 1 to 16, wherein detection of the mark of origin or fingerprint is by optical image capture or electronic image capture, in combination with other suitable optical elements including filters and lenses.

- 58 -

21. A method according to any of the preceding claims, wherein the mark of origin or fingerprint in the diamond material is formed by defect centres having optical properties that are not observed in natural diamond.
22. A method according to any one of claims 1 to 20, wherein the mark of origin or fingerprint in the diamond material is formed by defect centres, the measurable or observable distribution of the defect centres being in a form not observed in natural diamond.
23. A method according to any one of claims 1 to 20, wherein the mark of origin or fingerprint in the diamond material is formed by defect centres having optical properties, the combination of the optical properties and the measurable or observable distribution of the optical centres being in a form not observed in natural diamond.
24. A method according to any one of the preceding claims, wherein the fingerprint or mark of origin provides a means by which modification to the diamond can be identified.
25. A method according to claim 24, wherein the fingerprint or mark of origin provides a means by which modification to the diamond by means of annealing can be identified.
26. A method according to any of the preceding claims, wherein the fingerprint or mark of origin is used to identify the synthetic nature of the material.
27. A method according to any of the preceding claims, wherein the fingerprint or mark of origin is used to identify the manufacturer, or as a manufacturers process identification mark.

- 59 -

28. A method according to any one of the preceding claims, wherein the fingerprint or mark of origin is used as or in the manner of a trademark.
29. A method according to any one of the preceding claims, wherein the substrate is a diamond substrate having a surface on which growth takes place.
30. CVD single crystal diamond material bearing a mark of origin or fingerprint in the bulk thereof, which mark of origin or fingerprint is not readily detectable or does not affect the perceived quality of the diamond material under normal viewing conditions, but which mark of origin or fingerprint is detectable or rendered detectable under specialised viewing conditions.
31. CVD single crystal diamond material according to claim 30, which is prepared, or suitable for preparation, as a gemstone.
32. CVD single crystal diamond material according to claim 30, which is prepared as a gemstone, wherein the mark of origin or fingerprint in the diamond material is formed by defect centres having properties that are not observed in natural diamond.
33. CVD single crystal diamond material according to claim 30, which is prepared as a gemstone, wherein the mark of origin or fingerprint in the diamond material is formed by defect centres, the measurable or observable distribution of the defect centres being in a form not observed in natural diamond.
34. CVD single crystal diamond material according to claim 30, which is prepared as a gemstone, wherein the mark of origin or fingerprint in the diamond material is formed by defect centres having optical properties, the combination of the optical properties and the

- 60 -

measurable or observable distribution of the defect centres being in a form not observed in natural diamond.

35. CVD single crystal diamond material according to claim 30, which is prepared as a gemstone, wherein the mark of origin or fingerprint in the diamond material is formed by defect centres, the distribution of the defect centres being observable as a feature through the table of the gemstone.
36. CVD single crystal diamond material according to claim 35, wherein the feature observed in the table of the gemstone is a solid geometrical shape or an unfilled geometrical shape, the precise geometry of the geometrical shape reflecting the symmetry of the gemstone about an axis passing at 90° through the table of the gemstone.
37. CVD single crystal diamond material according to claim 35 or claim 36, wherein the gemstone is of a generally round form and the feature observable in the table of the stone is a spot or a ring.
38. CVD single crystal diamond material according to claim 37, wherein the gemstone is of a round brilliant form.
39. CVD single crystal diamond material according to claim 35 or claim 36, wherein the gemstone is of a rectangular form and the feature observable in the table of the stone is a solid square or a square outline.
40. CVD single crystal diamond material according to claim 35, wherein the feature observable in the table of the gemstone is formed by one or more layers below the girdle of the gemstone lying in a plane approximately parallel with the table of the gemstone.

- 61 -

41. CVD single crystal diamond material according to claim 30, wherein the single crystal diamond material is prepared for an industrial application in which it is a visible element to the user, or is re-useable or needs periodic reprocessing.
42. CVD single crystal diamond material according to claim 41, wherein the single crystal diamond material is a cutting blade or a component thereof.
43. CVD single crystal diamond material according to claim 42, wherein the single crystal diamond material is a diamond scalpel blade.
44. CVD single crystal diamond material according to any one of claims 30 to 43, wherein the mark of origin or fingerprint is in the form of a single group or pattern comprising one or more marking layers, each layer having a thickness within the range of 10 μm to 1000 μm .
45. CVD single crystal diamond material according to claim 44, wherein each layer has a thickness within the range of 20 μm to 600 μm .
46. CVD single crystal diamond material according to claim 45, wherein each layer has a thickness within the range of 50 μm to 400 μm .
47. CVD single crystal diamond material according to claim 46, wherein each layer has a thickness within the range of 100 μm to 250 μm .
48. CVD single crystal diamond material according to any one of claims 30 to 43, wherein the mark of origin or fingerprint is in the form of a multiple or repeating pattern each comprising one or more marking layers, each layer having a thickness within the range 2 μm to 100 μm .
49. CVD single crystal diamond material according to claim 48, wherein each layer has a thickness within the range 5 μm to 50 μm .

50. CVD single crystal diamond material according to any one of claims 30 to 49, which, under suitable illumination conditions, exhibits orange luminescence arising from 575 nm/637 nm N related defect centres and, under or after the same or other suitable illumination conditions, exhibits blue phosphorescence associated with donor acceptor pair recombination.
51. CVD single crystal diamond material according to any one of claims 30 to 50, which, under suitable illumination conditions, exhibits more than one discrete layer in which the ratio of the thicknesses of the layers is in accordance with a pre-determined pattern.
52. CVD single crystal diamond material according to claim 30, wherein the fingerprint or mark of origin comprises one or more layers free of defects with distinguishing properties embedded in a larger volume of material, which is marked by defects with distinguishing properties.
53. CVD single crystal diamond material according to any one of claims 30 to 52, wherein the fingerprint or mark of origin is used as or in the manner of a trademark.
54. An apparatus for detecting a mark of origin or fingerprint in a CVD single crystal diamond material bearing the mark of origin or fingerprint, the apparatus comprising:
- a body arranged to receive or hold CVD single crystal diamond material bearing the mark of origin or fingerprint;
 - a source of light or radiation arranged to direct the light or radiation at the CVD single crystal diamond material, the light or radiation being of a wavelength suitable for causing excitation of the mark of origin or fingerprint resulting in luminescence and/or

- 63 -

phosphorescence thereof to expose the mark of origin or fingerprint; and

a detection means for detecting the exposed mark of origin or fingerprint.

55. An apparatus according to claim 54, wherein the detection means comprises a viewer for viewing the luminescence and/or phosphorescence, or an instrument providing a measure of the intensity of the specific luminescence and/or phosphorescence.
56. An apparatus according to claim 55, wherein the measure of the intensity of the specific luminescence and/or phosphorescence is in the form of an analogue or digital electrical signal, or display readout.
57. An apparatus according to any one of claims 54 to 56, wherein the apparatus comprises a range of optical filters for viewing the wavelengths emitted by the mark of origin or fingerprint, and means for excluding background white light or wavelengths present which may be detrimental to observing the wavelengths emitted by the mark.
58. An apparatus according to any one of claims 54 to 57, further comprising magnification means for magnifying the exposed mark of origin or fingerprint in the CVD single crystal diamond material.
59. An apparatus according to claim 54, wherein the apparatus is arranged preferentially to excite 575 nm and/or 637 nm luminescence.
60. An apparatus according to claim 54, wherein the apparatus is arranged preferentially to excite blue band phosphorescence peaking in the region of 400 – 500 nm.

- 64 -

61. An apparatus according to claim 54, wherein the apparatus is arranged preferentially to excite 575 nm and/or 637 nm luminescence and thereafter preferentially to excite blue band phosphorescence peaking in the region of 400 –500 nm.
62. An apparatus according to claim 54, wherein the apparatus is arranged preferentially to excite the 737 nm luminescence peak.
63. An apparatus according to claim 59, further comprising one or more optical filters for enhancing detection of the 575 and/or 637 nm luminescence.
64. An apparatus according to claim 63, comprising an optical filter arranged to block the transmission of wavelengths near 450 nm, thereby to enhance viewing or detection of the 575/637 nm luminescence.
65. An apparatus according to claims 60, further comprising one or more optical filters for enhancing detection of the blue band phosphorescence peaking in the range 400 – 500 nm.
66. An apparatus according to any one of claims 59, 61, 63 or 64, wherein the source of light or radiation is selected to provide illumination in the 300 – 550 nm range.
67. An apparatus according to claim 66, wherein the source of light or radiation is a high power light emitting diode.
68. An apparatus according to any one of claims 60, 61 or 65, wherein the source of light or radiation is selected to provide illumination in the 225 - 275 nm range.

- 65 -

69. An apparatus according to claim 68, wherein the source of light or radiation is a pulsed Xenon source.
70. An apparatus according to claim 68 or claim 69, wherein the source of light further comprises a filter to exclude wavelengths outside the range 225-275 nm.
71. An apparatus according to any one of claims 68 to 70, wherein an observer or detector is protected from UV radiation from the source of light or radiation by the use of a window, such as a glass or Perspex window, which absorbs UV in the range 225 – 275 nm.
72. An apparatus according to claim 62, wherein the source of light or radiation is selected to provide illumination in the range 480 – 700 nm.
73. An apparatus according to claim 72, wherein the source of light or radiation is a 633 HeNe laser.
74. A method of viewing or detecting a mark of origin or fingerprint in a CVD single crystal diamond material bearing the mark of origin or fingerprint, which mark of origin or fingerprint is not visible under normal viewing conditions, the method including the steps of:
- a) directing a source of light or radiation at the CVD single crystal diamond material, the light or radiation being of a wavelength suitable for causing excitation of the mark of origin or fingerprint resulting in luminescence and/or phosphorescence thereof to expose the mark of origin or fingerprint; and
 - b) viewing or detecting the exposed mark of origin or fingerprint.

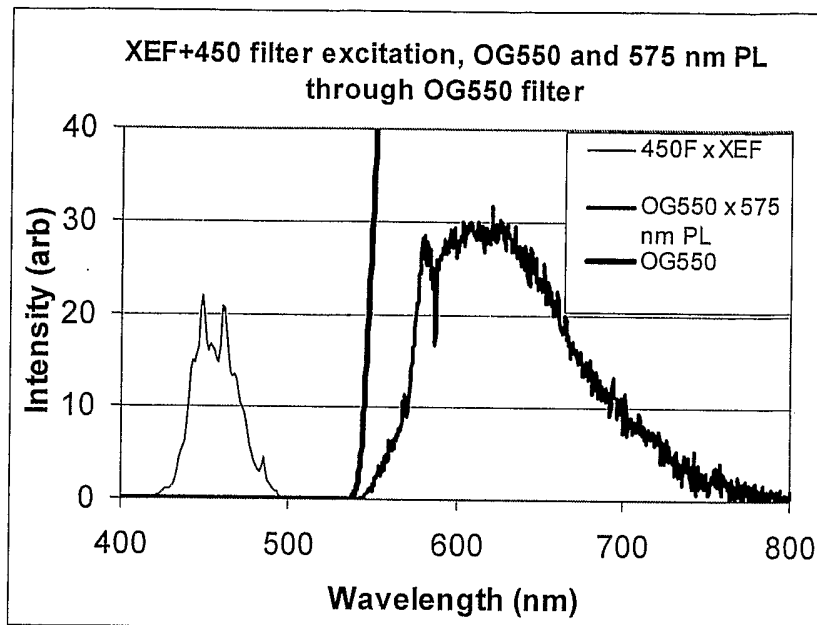

Fig. 1

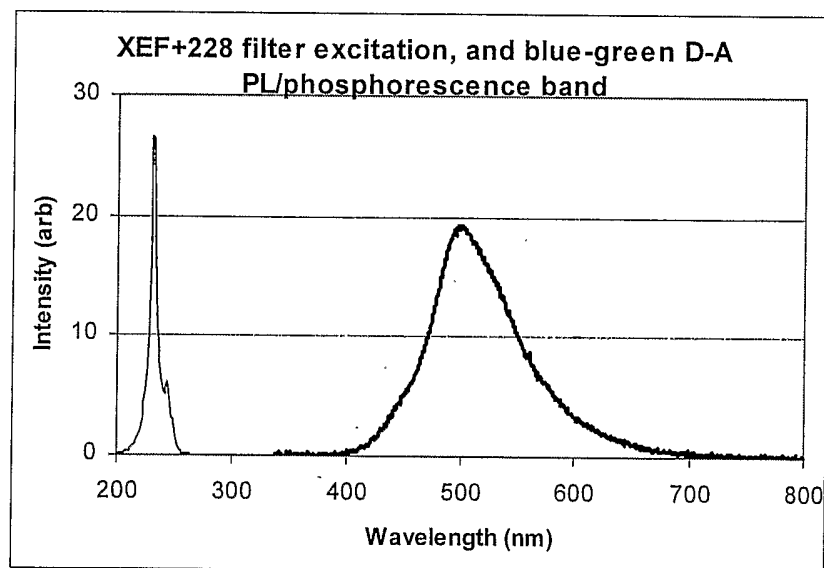

Fig. 2

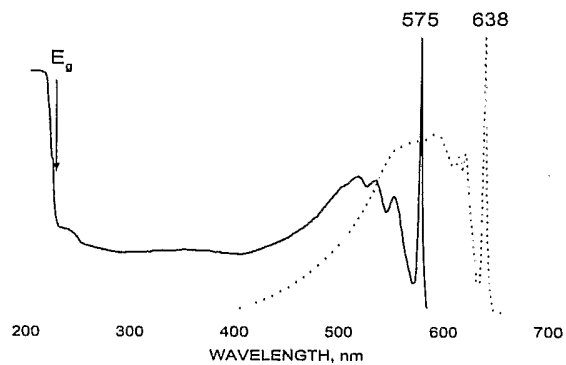

Fig. 3

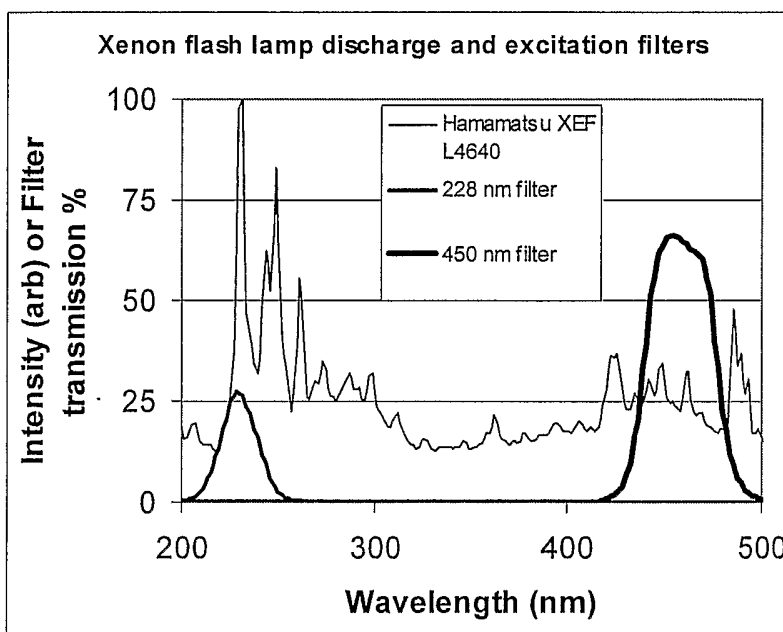
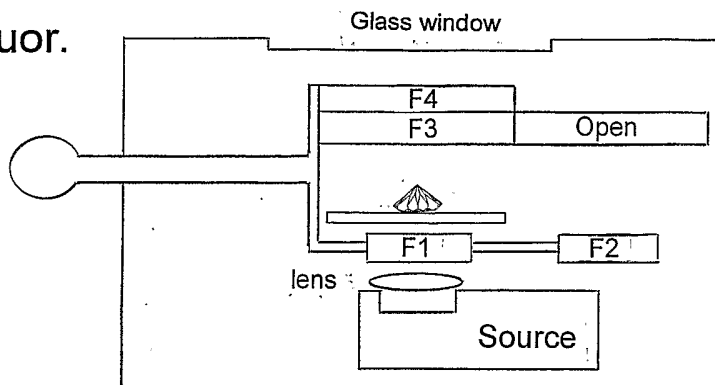

Fig. 4

575 orange fluor.



Blue-green phos.

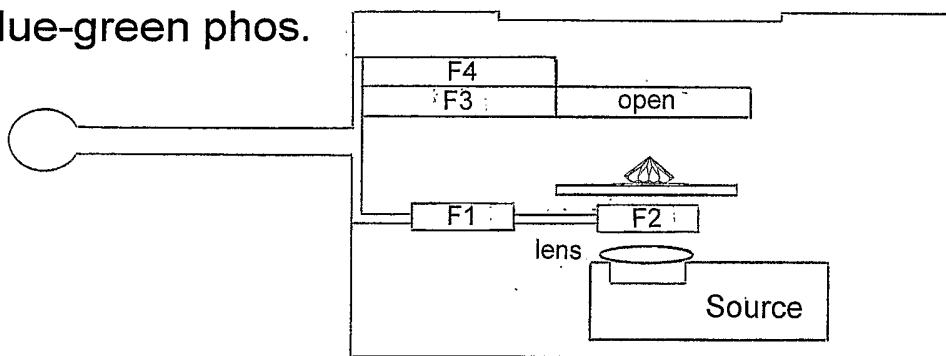
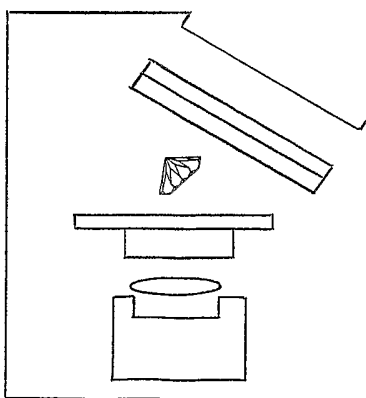

Fig. 5



Side view

Fig. 6

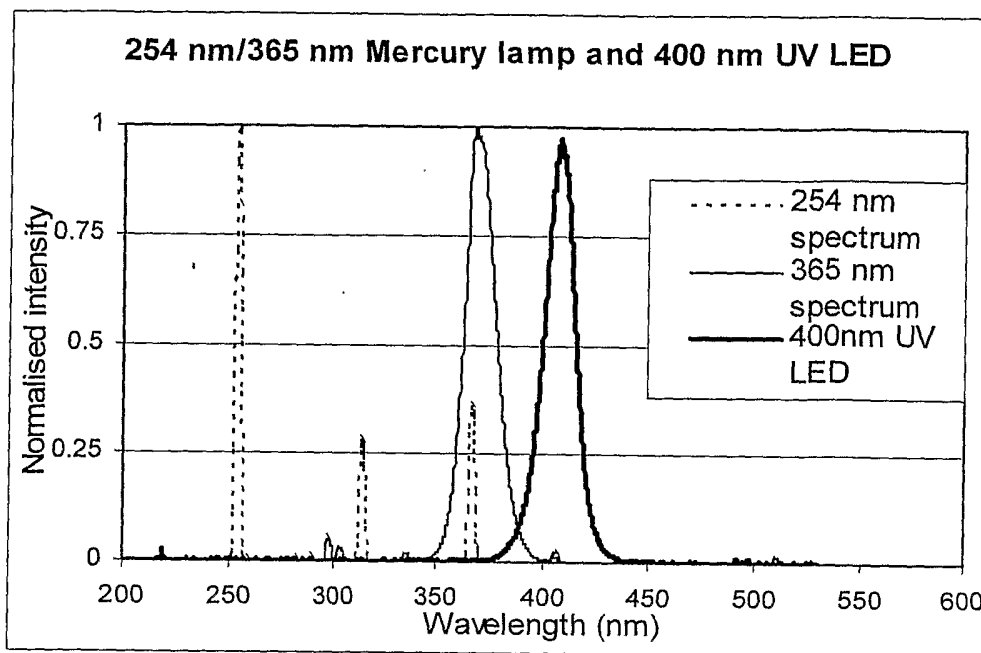

Fig.7

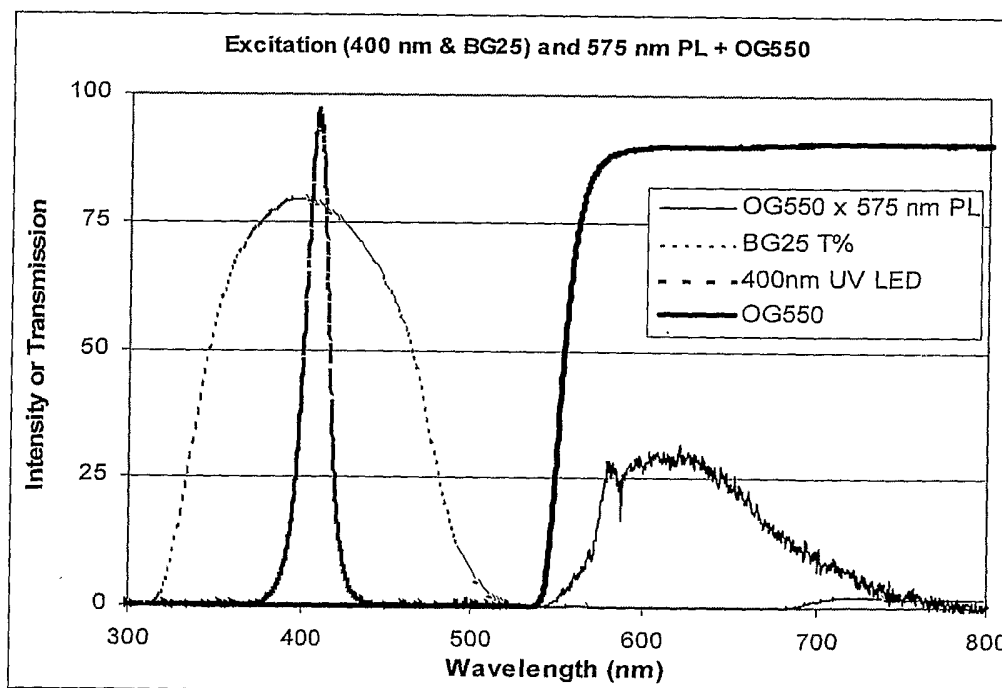

Fig.8

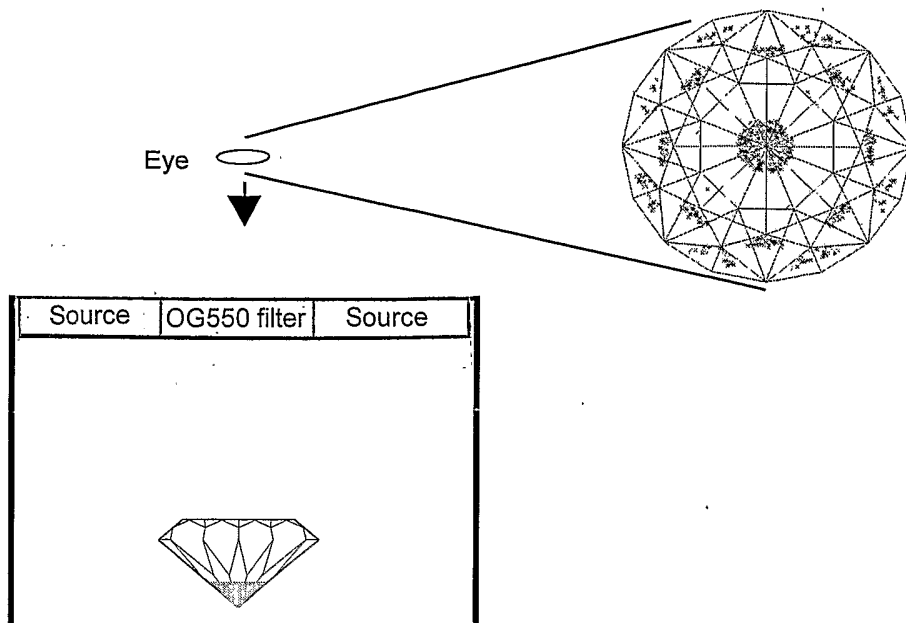

Fig.9(a)

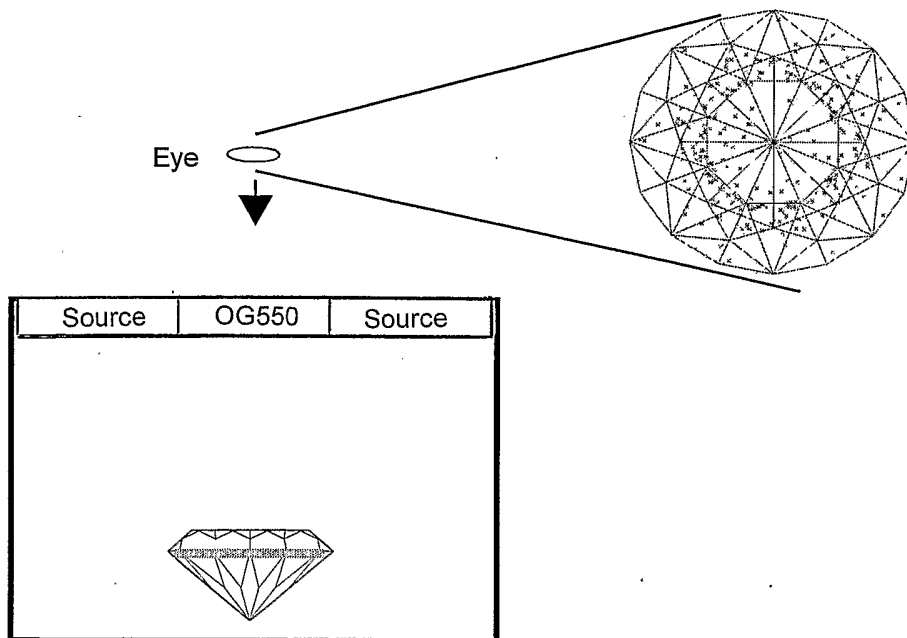

Fig.9(b)

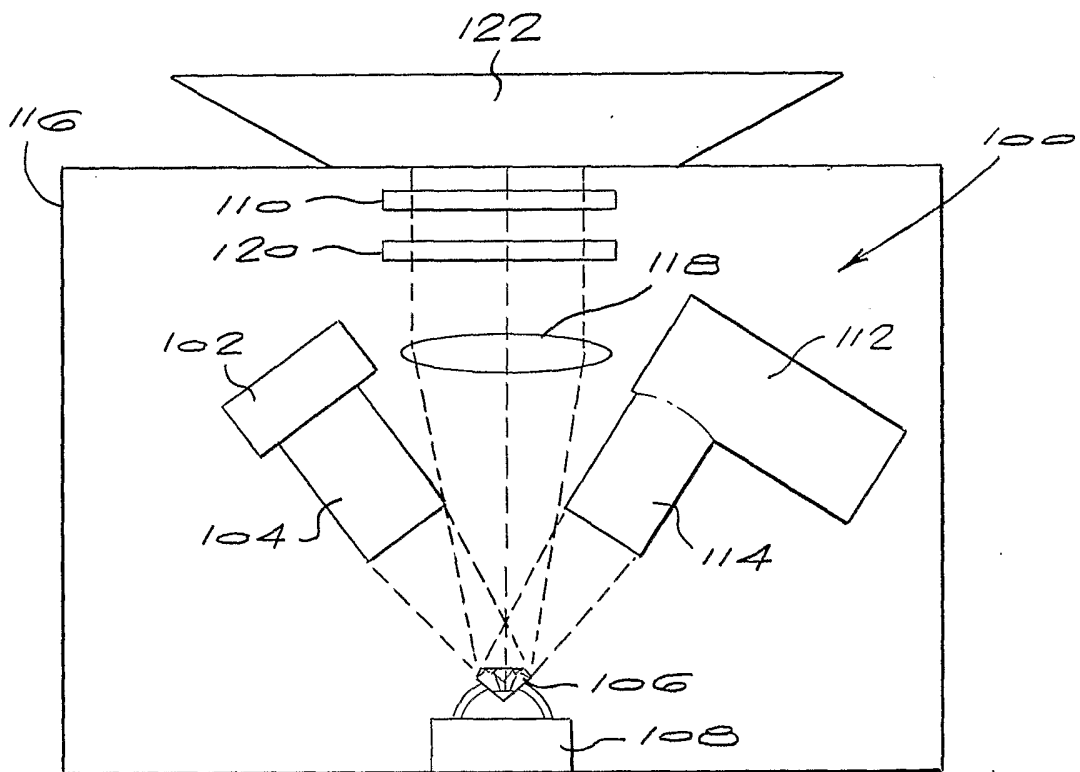

Fig.10

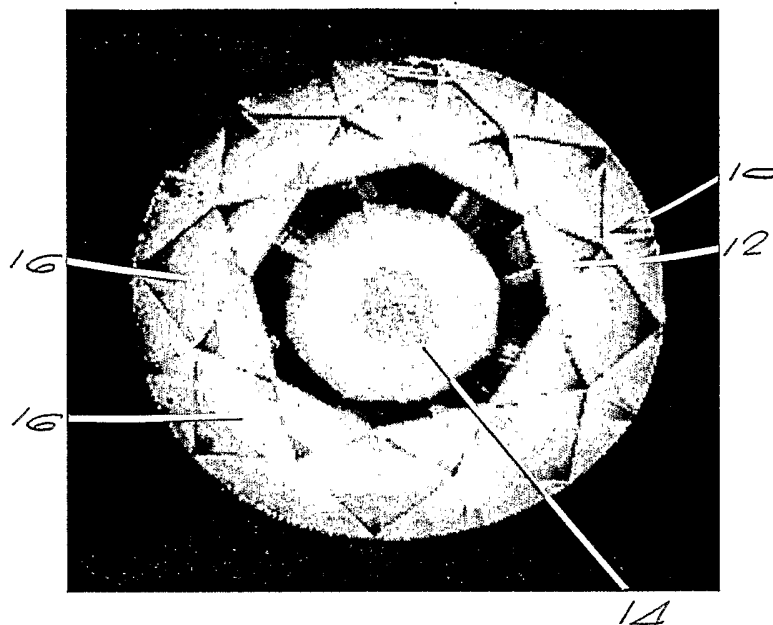

Fig. 11

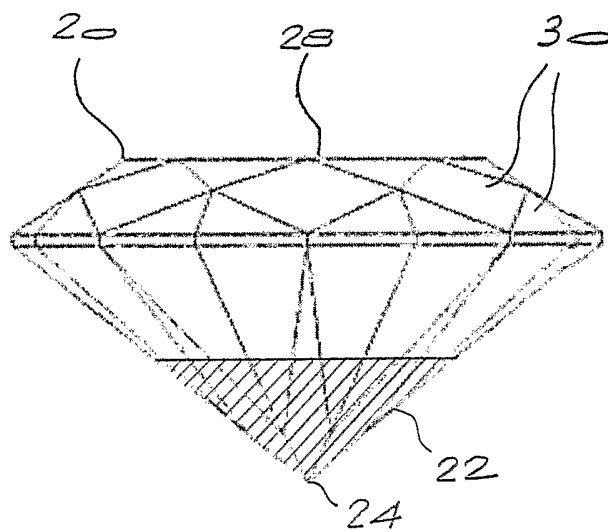
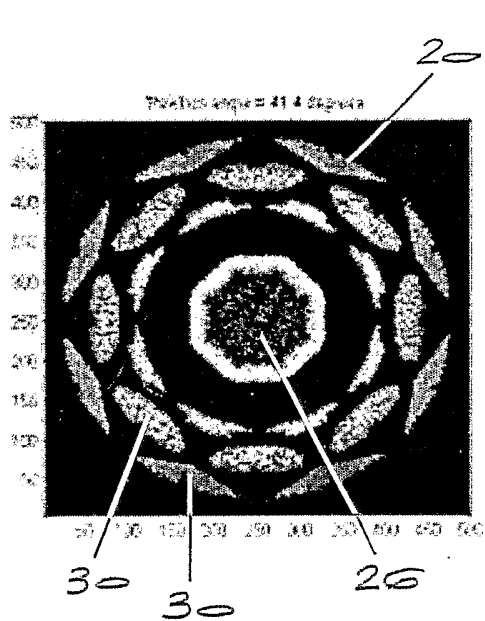

Fig. 12

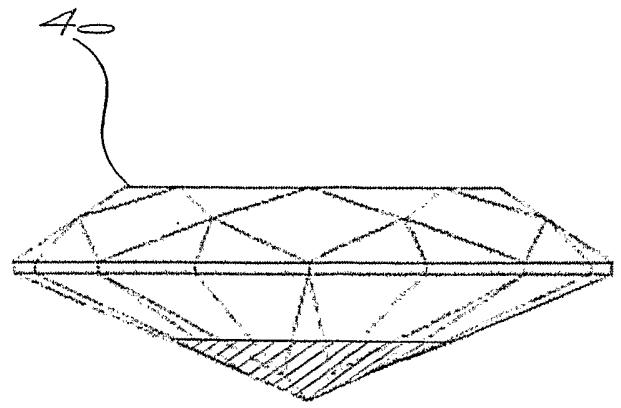
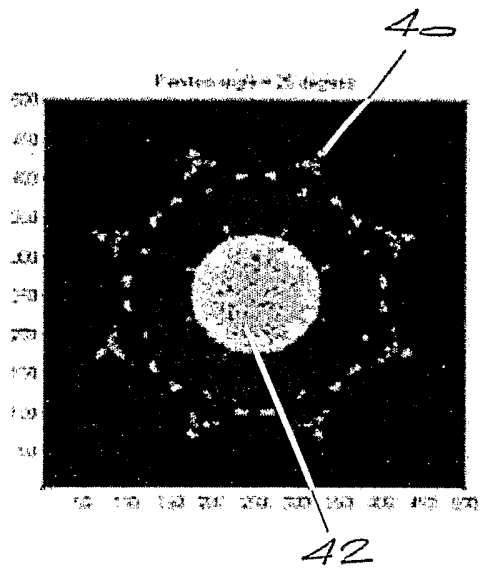

Fig. 13

Fig.14

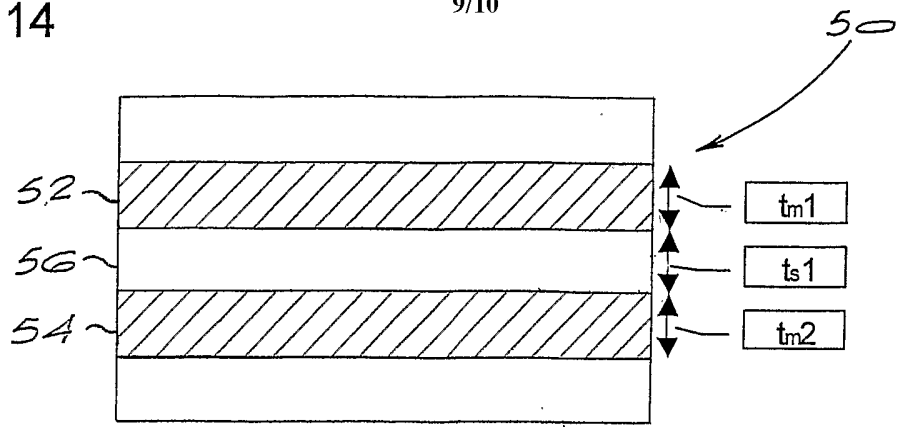

Fig.15

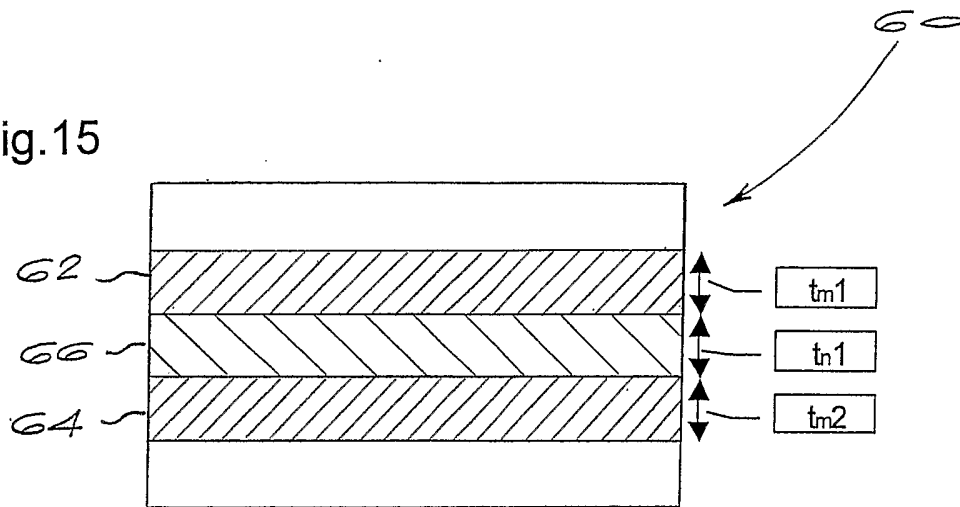
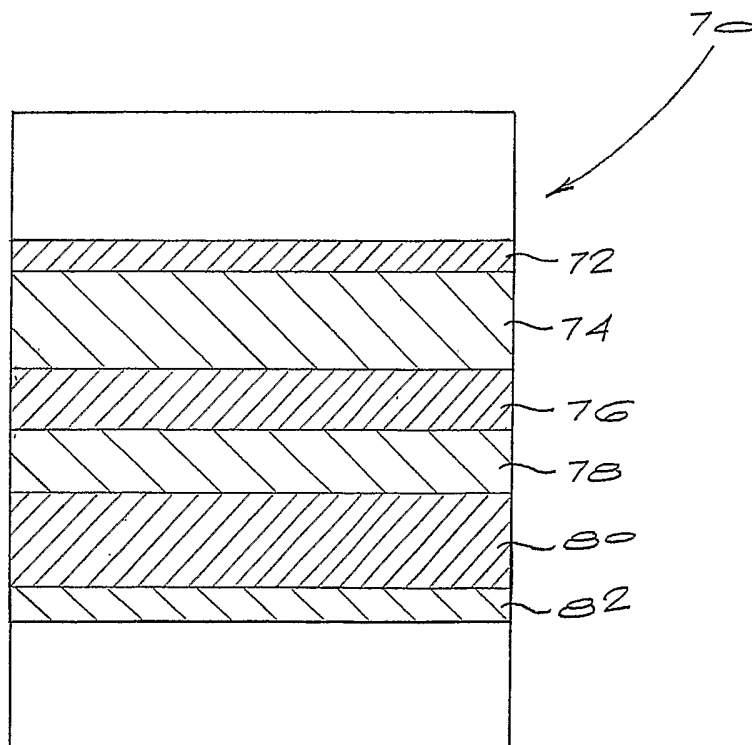

Fig.16



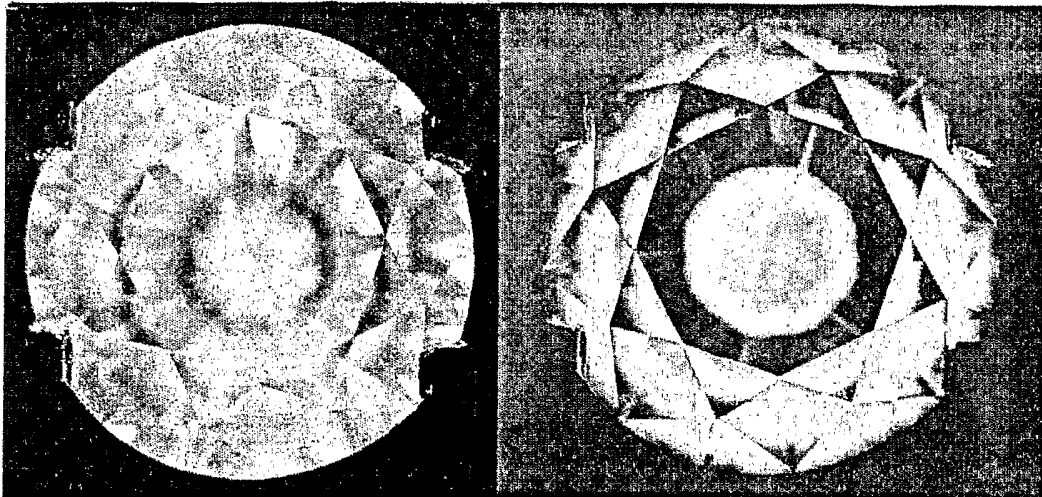

Fig.17

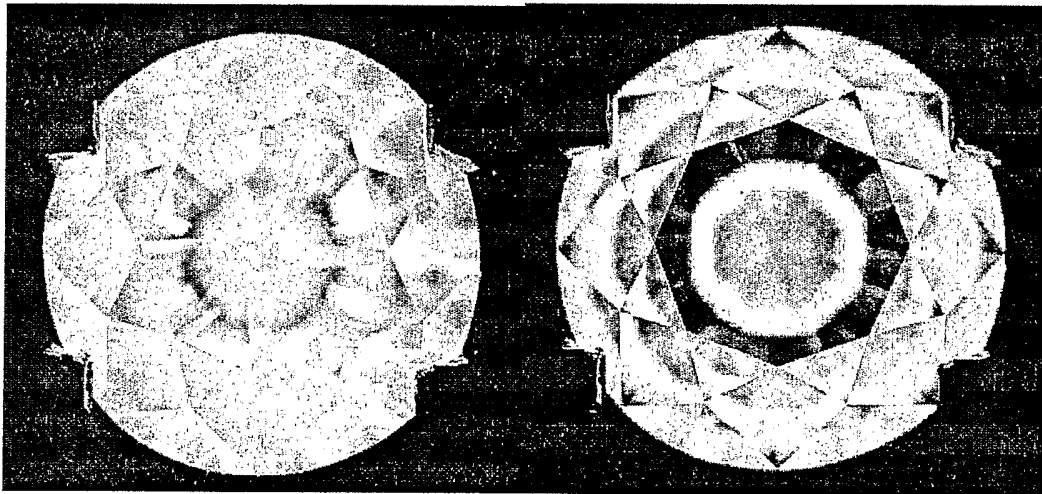

Fig.18

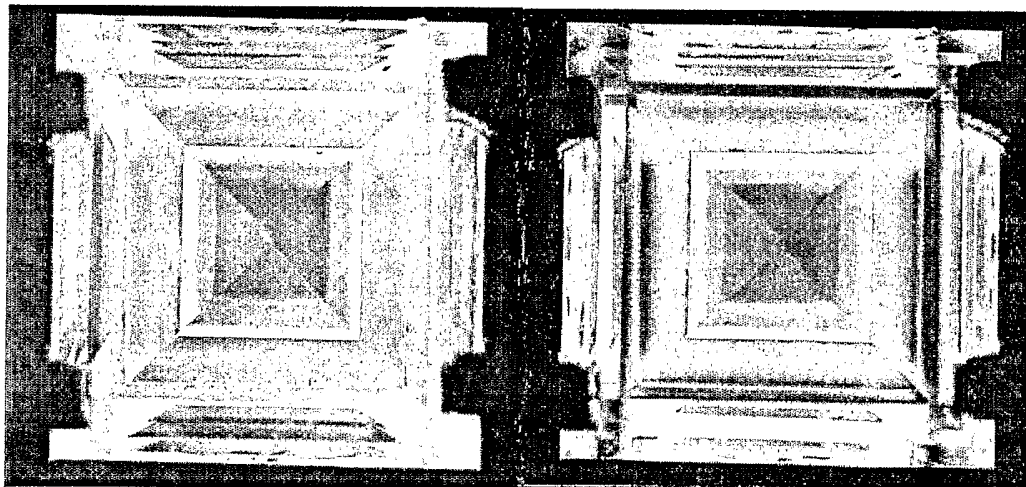

Fig.19

INTERNATIONAL SEARCH REPORT

Int. Application No
PCT/IB2004/004069

A. CLASSIFICATION OF SUBJECT MATTER
IPC 7 C30B29/04

According to International Patent Classification (IPC) or to both national classification and IPC

B. FIELDS SEARCHED

Minimum documentation searched (classification system followed by classification symbols)
IPC 7 C30B A44C

Documentation searched other than minimum documentation to the extent that such documents are included in the fields searched

Electronic data base consulted during the international search (name of data base and, where practical, search terms used)

EPO-Internal, PAJ

C. DOCUMENTS CONSIDERED TO BE RELEVANT

Category °	Citation of document, with indication, where appropriate, of the relevant passages	Relevant to claim No.
X	WO 03/014427 A (APOLLO DIAMOND, INC) 20 February 2003 (2003-02-20) the whole document	1-53
X	US 2003/205190 A1 (LINARES ROBERT C ET AL) 6 November 2003 (2003-11-06) paragraph '0070!	30, 31
Y	US 6 187 213 B1 (SMITH JAMES GORDON CHARTERS ET AL) 13 February 2001 (2001-02-13) examples 1,2	30, 31
Y	US 4 316 385 A (DEVRIES ET AL) 23 February 1982 (1982-02-23) column 2, line 23 - line 62	30, 31
	----- -/-- -----	

Further documents are listed in the continuation of box C.

Patent family members are listed in annex.

° Special categories of cited documents:

- *A* document defining the general state of the art which is not considered to be of particular relevance
- *E* earlier document but published on or after the international filing date
- *L* document which may throw doubts on priority claim(s) or which is cited to establish the publication date of another citation or other special reason (as specified)
- *O* document referring to an oral disclosure, use, exhibition or other means
- *P* document published prior to the international filing date but later than the priority date claimed

- *T* later document published after the international filing date or priority date and not in conflict with the application but cited to understand the principle or theory underlying the invention
- *X* document of particular relevance; the claimed invention cannot be considered novel or cannot be considered to involve an inventive step when the document is taken alone
- *Y* document of particular relevance; the claimed invention cannot be considered to involve an inventive step when the document is combined with one or more other such documents, such combination being obvious to a person skilled in the art.
- *&* document member of the same patent family

Date of the actual completion of the international search

14 April 2005

Date of mailing of the international search report

26/04/2005

Name and mailing address of the ISA

European Patent Office, P.B. 5818 Patentlaan 2
NL - 2280 HV Rijswijk
Tel. (+31-70) 340-2040, Tx. 31 651 epo nl,
Fax: (+31-70) 340-3016

Authorized officer

Cook, S

INTERNATIONAL SEARCH REPORT

 Intl. Patent Application No
 PCT/IB2004/004069

C.(Continuation) DOCUMENTS CONSIDERED TO BE RELEVANT		
Category °	Citation of document, with indication, where appropriate, of the relevant passages	Relevant to claim No.
X	LU T ET AL: "Characterization of a notable historic gem diamond showing the alexandrite effect" JOURNAL OF CRYSTAL GROWTH, NORTH-HOLLAND PUBLISHING CO. AMSTERDAM, NL, vol. 193, no. 4, 15 October 1998 (1998-10-15), pages 577-584, XP004144488 ISSN: 0022-0248 page 581, right-hand column	54
T	-& GIA Instruments UK LTD http://www.giainstruments.co.uk/DiamondView XP002324550 abstract	54-74
A	----- US 5 124 935 A (WALLNER ET AL) 23 June 1992 (1992-06-23) the whole document	54
A	----- EP 0 341 093 A (GERSAN ESTABLISHMENT) 8 November 1989 (1989-11-08) claim 8	54
A	----- WO 01/96634 A (DE BEERS INDUSTRIAL DIAMONDS LIMITED; SCARSBROOK, GEOFFREY, ALAN; MAR) 20 December 2001 (2001-12-20) cited in the application	
A	----- US 4 200 506 A (DRESCHHOFF, GISELA A M ET AL) 29 April 1980 (1980-04-29)	
A	----- US 6 391 215 B1 (SMITH JAMES GORDON CHARTERS ET AL) 21 May 2002 (2002-05-21)	
A	----- GB 2 332 651 A (* GERSAN ESTABLISHMENT) 30 June 1999 (1999-06-30)	
A	----- US 2003/223054 A1 (WARWICK MALCOLM RAYMOND) 4 December 2003 (2003-12-04)	
A	----- US 6 211 484 B1 (KAPLAN GEORGE R ET AL) 3 April 2001 (2001-04-03)	

INTERNATIONAL SEARCH REPORT

 International Application No
 PCT/IB2004/004069

Patent document cited in search report		Publication date	Patent family member(s)	Publication date
WO 03014427	A	20-02-2003	WO 03014427 A1	20-02-2003
			CA 2456847 A1	20-02-2003
			EP 1415022 A1	06-05-2004
			JP 2004538230 T	24-12-2004

US 2003205190	A1	06-11-2003	US 6582513 B1	24-06-2003
			US 2005056206 A1	17-03-2005
			US 2005056207 A1	17-03-2005
			US 2005056208 A1	17-03-2005
			US 2005056209 A1	17-03-2005
			US 2005061233 A1	24-03-2005
			US 2005066884 A1	31-03-2005
			US 2003131787 A1	17-07-2003

US 6187213	B1	13-02-2001	AU 708323 B2	29-07-1999
			AU 6524796 A	18-02-1997
			CA 2227185 A1	06-02-1997
			CN 1196018 A ,C	14-10-1998
			DE 69618201 D1	31-01-2002
			DE 69618201 T2	18-07-2002
			EP 0839098 A1	06-05-1998
			ES 2166459 T3	16-04-2002
			WO 9703846 A1	06-02-1997
			GB 2319225 A ,B	20-05-1998
			HK 1009786 A1	20-04-2000
			IL 118886 A	31-12-1999
			JP 2000501652 T	15-02-2000
			RU 2161093 C2	27-12-2000
			TW 380093 B	21-01-2000
			US 2002108398 A1	15-08-2002

US 4316385	A	23-02-1982	NONE	

US 5124935	A	23-06-1992	AT 109563 T	15-08-1994
			AU 8926791 A	25-06-1992
			WO 9209882 A1	11-06-1992
			DE 69103282 D1	08-09-1994
			DE 69103282 T2	16-03-1995
			EP 0559699 A1	15-09-1993
			HK 30797 A	21-03-1997
			JP 6503166 T	07-04-1994

EP 0341093	A	08-11-1989	AU 646719 B2	03-03-1994
			AU 1077692 A	14-05-1992
			AU 646542 B2	24-02-1994
			AU 1077892 A	14-05-1992
			AU 626860 B2	13-08-1992
			AU 3453989 A	09-11-1989
			AU 630351 B2	29-10-1992
			AU 3454089 A	09-11-1989
			AU 622665 B2	16-04-1992
			AU 3454189 A	09-11-1989
			AU 622666 B2	16-04-1992
			AU 3454289 A	09-11-1989
			AU 623140 B2	07-05-1992
			AU 3454389 A	09-11-1989
			AU 622667 B2	16-04-1992
			AU 3454489 A	09-11-1989

INTERNATIONAL SEARCH REPORT

International Application No

PCT/IB2004/004069

Patent document cited in search report	Publication date	Patent family member(s)	Publication date	
EP 0341093	A	BR 8902133	A 02-01-1990	
		BR 8902134	A 02-01-1990	
		BR 8902135	A 04-09-1990	
		BR 8902136	A 04-09-1990	
		BR 8902137	A 02-01-1990	
		BR 8902138	A 02-01-1990	
		CA 1334895	C 28-03-1995	
		DE 341092	T1 16-08-1990	
		DE 341093	T1 11-04-1991	
		DE 341094	T1 11-04-1991	
		DE 341095	T1 16-08-1990	
		DE 341096	T1 11-04-1991	
		DE 345949	T1 06-09-1990	
		EP 0341092	A2 08-11-1989	
		EP 0341093	A2 08-11-1989	
		EP 0341094	A2 08-11-1989	
		EP 0341095	A2 08-11-1989	
		EP 0341096	A2 08-11-1989	
		EP 0345949	A2 13-12-1989	
		EP 0552819	A2 28-07-1993	
		EP 0552820	A2 28-07-1993	
		EP 0552821	A2 28-07-1993	
		GB 2219394	A , B 06-12-1989	
		GB 2219078	A , B 29-11-1989	
		GB 2219079	A , B 29-11-1989	
		GB 2219080	A , B 29-11-1989	
		GB 2219081	A , B 29-11-1989	
		GB 2219082	A , B 29-11-1989	
		GB 2251305	A , B 01-07-1992	
		GB 2251306	A , B 01-07-1992	
		IN 174122	A1 17-09-1994	
		IN 174123	A1 17-09-1994	
		IN 174165	A1 01-10-1994	
IN 174124	A1 17-09-1994			
WO 0196634	A	20-12-2001	AU 6624601	A 24-12-2001
			CA 2412855	A1 20-12-2001
			CN 1441859	A 10-09-2003
			CZ 20024228	A3 17-12-2003
			EP 1290251	A1 12-03-2003
			GB 2379451	A , B 12-03-2003
			WO 0196634	A1 20-12-2001
			JP 2004503461	T 05-02-2004
			US 2004182308	A1 23-09-2004
			ZA 200210138	A 12-12-2003
			US 4200506	A
US 6391215	B1	21-05-2002	AT 232476	T 15-02-2003
			AU 732638	B2 26-04-2001
			AU 7541298	A 11-12-1998
			CA 2291041	A1 26-11-1998
			CN 1265066	A , C 30-08-2000
			DE 69811362	D1 20-03-2003
			DE 69811362	T2 16-10-2003
			EP 0984865	A1 15-03-2000
			ES 2190079	T3 16-07-2003
			GB 2361671	A , B 31-10-2001

INTERNATIONAL SEARCH REPORT

Int'l Application No
PCT/IB2004/004069

Patent document cited in search report	Publication date	Patent family member(s)	Publication date	
US 6391215	B1	GB 2325392 A	25-11-1998	
		WO 9852774 A1	26-11-1998	
		GB 2339727 A ,B	09-02-2000	
		HK 1024211 A1	31-05-2002	
		IL 124592 A	25-07-2002	
		JP 2001527477 T	25-12-2001	
		RU 2199447 C2	27-02-2003	
		TW 495422 B	21-07-2002	
		ZA 9804377 A	22-02-2002	
		ZA 200201200 A	22-08-2002	
GB 2332651	A	30-06-1999	AU 746557 B2	02-05-2002
			AU 1774399 A	19-07-1999
			CA 2316957 A1	08-07-1999
			CN 1284916 A ,C	21-02-2001
			DE 69820295 D1	15-01-2004
			DE 69820295 T2	21-10-2004
			EP 1042132 A1	11-10-2000
			ES 2212385 T3	16-07-2004
			WO 9933671 A1	08-07-1999
			HK 1020032 A1	19-04-2002
			JP 2001526996 T	25-12-2001
			RU 2215659 C2	10-11-2003
			TW 458836 B	11-10-2001
			ZA 9811838 A	23-06-2000
US 2003223054	A1	04-12-2003	AU 2003233705 A1	12-12-2003
			WO 03099054 A2	04-12-2003
US 6211484	B1	03-04-2001	US 5932119 A	03-08-1999
			US 2003019852 A1	30-01-2003
			US 6476351 B1	05-11-2002
			US 2004154825 A1	12-08-2004
			US 2004159641 A1	19-08-2004
			US 2005005642 A1	13-01-2005
			AU 699816 B2	17-12-1998
			AU 7736996 A	01-08-1997
			BR 9612467 A	13-07-1999
			CA 2238612 A1	17-07-1997
			CN 1425912 A	25-06-2003
			CN 1205663 A ,C	20-01-1999
			EP 1021271 A1	26-07-2000
			IL 124034 A	23-12-2001
			IL 140512 A	31-07-2003
			IL 140513 A	17-09-2003
			JP 3238875 B2	17-12-2001
			JP 9225659 A	02-09-1997
			JP 2002028793 A	29-01-2002
			RU 2205733 C2	10-06-2003
WO 9725177 A1	17-07-1997			