

[54] **SECTIONALIZED SELF-CONTAINED AIR CONDITIONING UNIT**

[72] Inventor: **John C. Mather**, Clarksville, Tenn.  
 [73] Assignee: **The Trane Company**, La Crosse, Wis.  
 [22] Filed: **Sept. 14, 1970**  
 [21] Appl. No.: **71,991**

[52] U.S. Cl. .... **62/262, 62/298**  
 [51] Int. Cl. .... **F25d 23/12**  
 [58] Field of Search .... **62/262, 298, 302, 408**

**References Cited**

**UNITED STATES PATENTS**

3,372,557 3/1968 **Dyas** .....62/262  
 2,115,288 4/1938 **Smith** .....62/297  
 2,984,089 5/1961 **Whitesel** .....62/262  
 2,604,763 7/1952 **Lipman** .....62/262

2,885,142 5/1959 **Eberhart** .....62/262  
 3,152,456 10/1964 **Prendergast** .....62/262

*Primary Examiner*—Meyer Perlin  
*Attorney*—Arthur O. Andersen and Carl M. Lewis

[57] **ABSTRACT**

An air-cooled condenser section has its own support pan capable of supporting the components of the condenser section independently of the evaporator section. The evaporator has a subframe which extends outwardly therefrom for attachment in underlying relationship to the condenser section to thereby define a self-contained unitary air conditioning unit. The evaporator section has a recessed sidewall defining a channel for conducting cooling air to a portion of the condenser section embraced by the evaporator section. Vertically oriented compressor, heat exchangers, and blowers in both evaporator and condenser sections permit the use of the same size bottoms, tops, and subframe for different size units.

**7 Claims, 5 Drawing Figures**

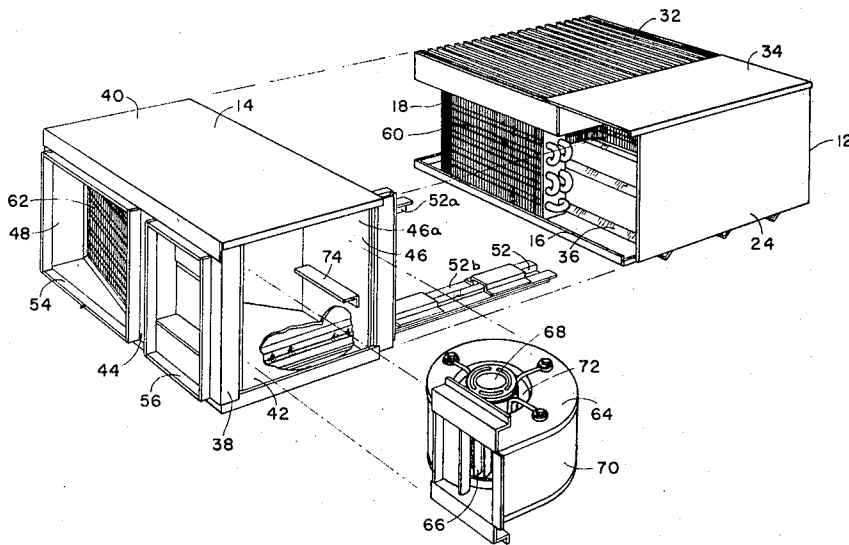

Patented May 30, 1972

3,665,727

5 Sheets-Sheet 1

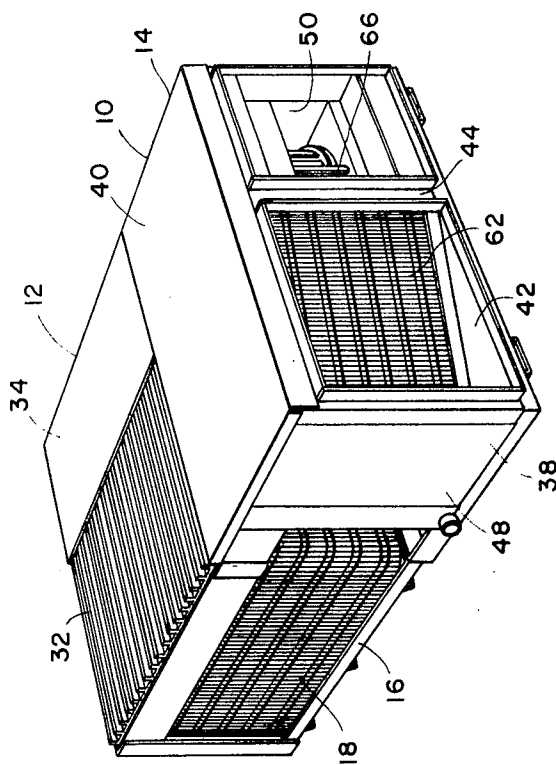

FIG. 1

INVENTOR.  
JOHN C. MATHER

BY

*Carl M. Lewis*  
ATTORNEY

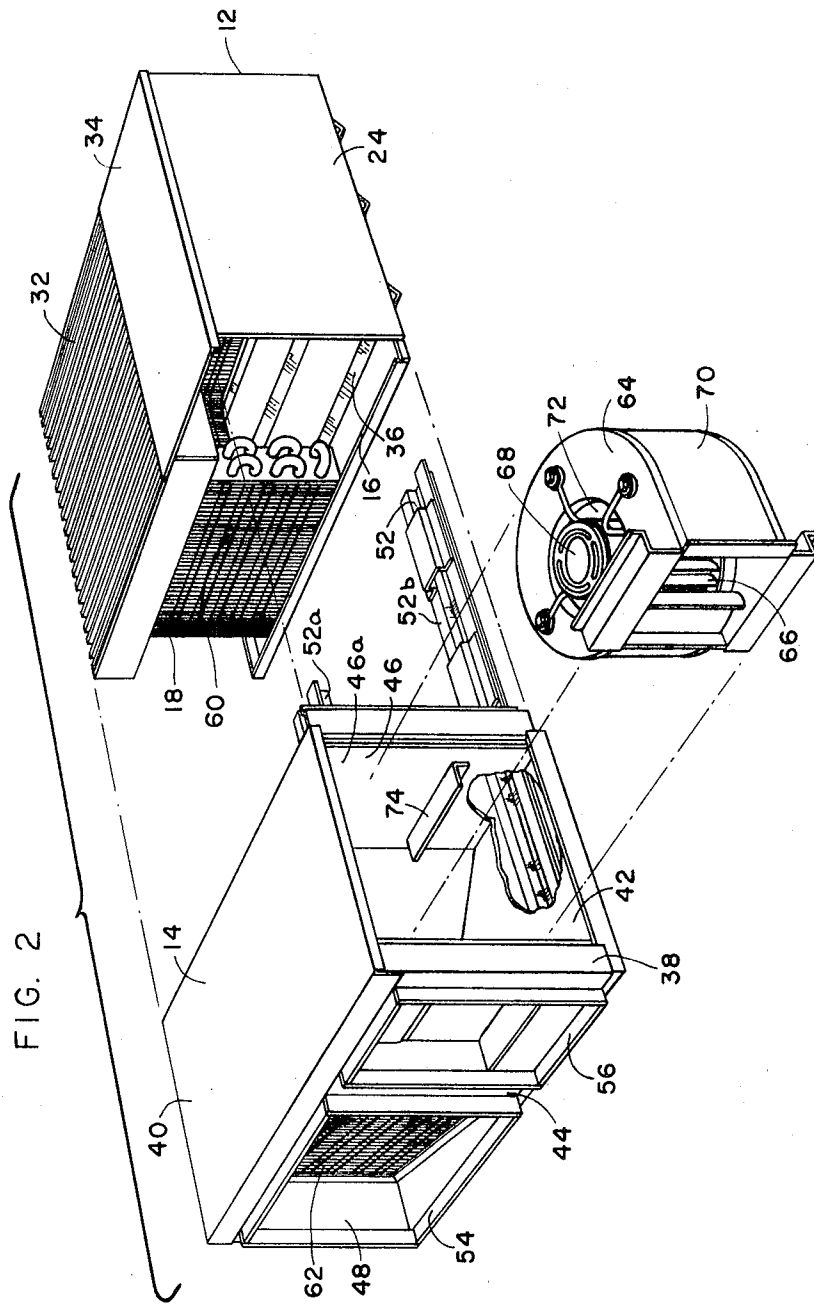

FIG. 2

INVENTOR.  
JOHN C. MATHER

BY

*Carl M. Lewis*  
ATTORNEY

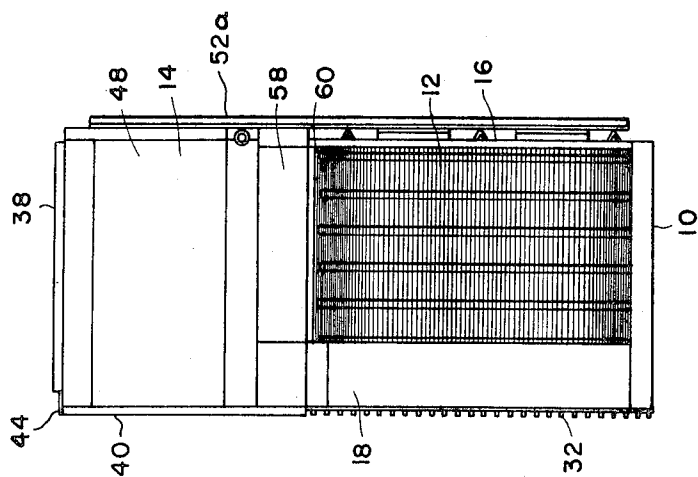

FIG. 5

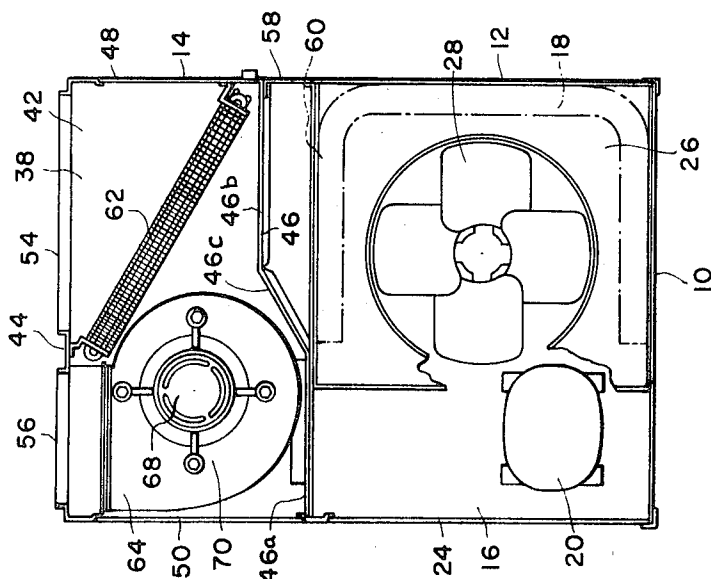

FIG. 3

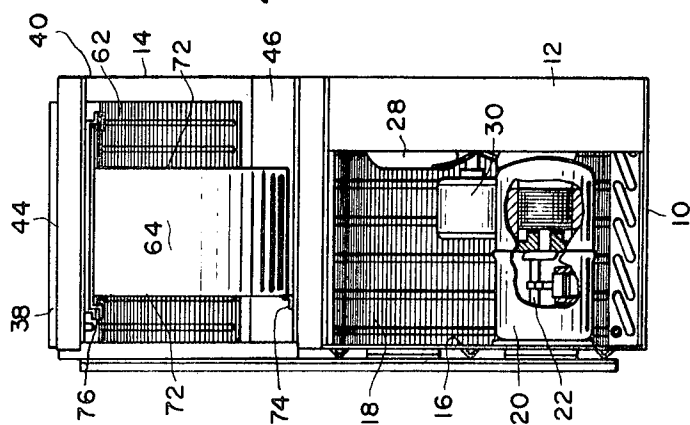

FIG. 4

INVENTOR.  
JOHN C. MATHER

BY

*Carl M. Lewis*  
ATTORNEY

## SECTIONALIZED SELF-CONTAINED AIR CONDITIONING UNIT

### BACKGROUND OF THE INVENTION

A great many residential and small commercial central type air conditioning systems produced today are of the type known as a split system wherein the condenser section containing an air-cooled refrigerant condenser heat exchanger, a refrigerant compressor, and a condenser fan or blower are mounted usually outdoors as a unit remote from the evaporator section which usually is disposed in the plenum of the furnace associated with the conditioned space.

Another type of air conditioning system in common use today is the self-contained unit in which the components immediately associated with both the evaporator and condenser are mounted on one common bottom wall or frame of a common housing. Such units may be mounted in crawl spaces, on the roof, or on a slab immediately adjacent the structure to be air conditioned. The air to be conditioned is ducted to and from the self-contained unit.

The existence of these two basic types of residential and small commercial air conditioning equipment has lead most manufacturers to produce two completely separate lines of products requiring substantially completely separate tooling and production lines for the two products. The duplicated costs are multiplied in most cases where different size units are made available. These costs must ultimately be reflected in the consumer prices of this residential and small commercial air conditioning equipment.

### SUMMARY OF THE INVENTION

The primary objective achieved by the instant invention is to provide a self-contained type air conditioning unit which utilizes the basic structure of a split system condensing unit in combination with an evaporator section attachment whereby much of the tooling cost can be avoided.

Another object of the invention is to orient all components including the compressor, condenser, evaporator, condenser fan and evaporator fan in an altitude so that size variations vary primarily their vertical extent so that same top and bottom walls as well as subframe structure can be used for different size units.

Another object of the instant invention is to provide means associated with the evaporator section for conducting condenser cooling air for that portion of the condenser section which is embraced by the evaporator section attachment.

Other objects and advantages will become apparent as this specification proceeds to describe the invention with reference to the drawings in which like reference numerals designate like parts throughout wherein:

FIG. 1 is a perspective of the self-contained air conditioning unit embodying the invention;

FIG. 2 is an exploded perspective showing the separate condenser and evaporator sections of the air conditioning unit of FIG. 1. Also the evaporator blower has been slid outwardly from the evaporator section;

FIG. 3 is a plan view of the air conditioning unit of FIG. 1 having the top panels and condenser discharge grill removed;

FIG. 4 is an elevational showing one side of the air conditioning unit of FIG. 3 having side panels thereof removed and portions of the compressor sectioned; and

FIG. 5 is an elevation showing the other side of the air conditioning unit of FIG. 3 particularly showing the air inlet opening of a channel within the evaporator section for conducting air to the condenser section.

### DETAILED DESCRIPTION

Now referring to the drawing it will be seen that the self-contained air conditioning unit 10 is comprised of an air-cooled refrigerant condensing section 12 and an air-cooling refrigerant evaporator section 14.

The condenser section 12 includes a rectangular base or support pan 16 of sufficient rigidity to support, as an indepen-

dent unit, the U-shaped fin-and-tube type air-cooled refrigerant condenser heat exchanger 18 having vertical faces paralleling three edges of pan 16, the refrigerant reciprocating compressor 20 having a crankshaft 22 oriented for rotation about a vertical axis, the removable access side panel 24 for servicing compressor 20 and controls, the condenser discharge fan orifice plate 26 disposed above condenser heat exchanger 18, the condenser blower or fan 28 disposed at the orifice of plate 26, the condenser fan motor 30 drivingly connected to fan 30, the discharge grille 32, and top panel 34. Conventional fasteners, not shown, may be employed to connect these elements in the position shown in the drawings. Pan 16 is preferably provided with stiffening ribs 36 or corrugations at spaced intervals to permit condenser section 18 to be used as an independent condensing unit of an air conditioning split system.

Evaporator section 14 has a housing 38 including a top wall 40, a bottom wall 42, a front sidewall 44, a back sidewall 46, and first and second end sidewalls 48 and 50 respectively. A subframe 52 in the form of a pair of beams 52a and 52b constructed of sheet metal and having a channel shaped cross section is connected to the underside of bottom wall 42 and extends horizontally outwardly beyond housing 38 in underlying relationship to support pan 16 of condenser section 12. Appropriate screws and bolts, not shown, connect support pan 16 to evaporator section subframe 52.

The front sidewall 44 of evaporator section housing 38 has an inlet aperture 54 for receiving air to be cooled and an outlet aperture 56 for discharging air that has been cooled; apertures 54 and 56 being disposed in horizontally spaced side-by-side relationship. Back sidewall 46 has a first portion 46a (see FIGS. 2 and 3) which extends along the back edge of bottom wall 42 in an area opposite discharge aperture 56, and a second portion 46b disposed generally opposite inlet aperture 54 and which extends along a path closer to front sidewall 44 than first portion 46a and spaced from the back edge of bottom wall 42. The first and second portions, 46a and 46b, of back wall 46 are connected via an oblique portion, 46c. Portions 46b and 46c and those portions of top and bottom walls, 40 and 42, disposed rearwardly of portions 46b and 46c define a channel having an inlet opening at 58 for conducting cooling air to face 60 of condenser heat exchanger 18. It will be noted that the space between portion 46a of back wall 46 and front wall 44 is somewhat deeper than the space between portion 46b and front wall 44. A fin and tube evaporator heat exchanger 62 having a generally flat rectangular face extends between front wall 44 and sidewall 48 across inlet aperture 54 in the shallower space between front wall 44 and portion 46b of back wall 46 of housing 38 whereby air entering aperture 54 is directed through heat exchanger 62 and thereby cooled. A centrifugal blower 64 for moving the air from heat exchanger 62 out through discharge aperture 56 is disposed within the deeper space between portion 46a of back wall 46 and front wall 44. Evaporator blower 64 has an impeller 66 oriented to be rotatably driven about a vertical axis by motor 68 within blower housing 70. By disposing blower 64 in the deeper space, the blower may have a larger diameter and shorter vertical extent thereby providing ample space for air to pass from heat exchanger 62 to the air inlets 72 at the top and bottom sides of blower housing 70. Blower 64 is supported on rails 74 and 76 so that it may be horizontally slid from evaporator housing 38 after removal of sidewall 50 as shown in FIG. 2 for purposes of service.

Evaporator heat exchanger 62, compressor 20, condenser heat exchanger 18 and a refrigerant throttling means (not shown) are respectively serially connected in a conventional refrigerant circuit whereby heat is absorbed from the air passing through evaporator heat exchanger 62 and transferred to air passing through condenser heat exchanger 18.

The self-contained air conditioning unit may be made in a variety of capacities using the same top and bottom portions simply by varying the vertical extent of condenser heat exchanger 18, evaporator heat exchanger 62, compressor 20, evaporator blower 64 and condenser fan and motor 28 and 30.

From the foregoing description it will be seen that the self-contained air conditioning unit may be constructed by providing the condensing unit of a split system with an evaporator section attachment which has a subframe for supporting the condensing unit support pan. Further, the evaporator section attachment is provided with an air conducting channel for conducting condenser cooling air to that portion of the condenser unit covered by the evaporator section attachment.

Having now described in detail the preferred embodiment of my invention, I contemplate that many changes may be made without departing from the scope or spirit of my invention and I accordingly desire to be limited only by the claims.

I claim:

1. Refrigeration apparatus comprising:

an evaporator section having a housing; a refrigerant evaporator heat exchanger disposed in said housing; a first blower disposed in said housing for passing air in heat exchange relation with said refrigerant evaporator heat exchanger; and a first motor drivingly connected to said first blower; a frame supportingly connected to said refrigerant evaporator heat exchanger, said first blower, said first motor and said housing, said frame being disposed below said housing and extending horizontally substantially beyond said housing; an air cooled condenser section having a refrigerant condenser heat exchanger; a refrigerant compressor; a second blower disposed to pass cooling air over said condenser heat exchanger; a second motor drivingly connected to said second blower; and a support pan means disposed below said compressor and said condenser heat exchanger for supporting said condenser heat exchanger, said compressor, said second blower and said second motor independently of said evaporator section; the extending portion of said frame being disposed below and connected to said support pan means of said condensing unit.

2. Refrigeration apparatus comprising: a condensing section having a generally rectangular pan-like frame, and an air-cooled refrigerant condenser heat exchanger disposed on said frame and having a plurality of substantially vertical faces adjacent a plurality of margins of said pan-like frame; an evaporator section abutting said condenser section at one of said plurality of vertical faces of said condenser heat exchanger and having a housing including top, bottom and sidewalls, one of said sidewalls being disposed inwardly of the edges of said top and bottom walls to define a channel for conducting condenser cooling air for that portion of said condenser heat exchanger over which said evaporator section lies.

3. The apparatus as defined by claim 2 including a subframe underlying said evaporator section housing and extending horizontally beyond said housing to support said pan-like frame of said condenser section.

4. A self-contained air conditioning unit comprising in combination: an air-cooled condenser heat exchanger having a generally vertical face, an air cooling evaporator heat exchanger having a generally vertical face, a first blower

disposed to rotate about a vertical axis for passing air through said condenser heat exchanger, a reciprocating compressor having a crankshaft disposed to rotate about a vertical axis, and a centrifugal blower having a cylindrical housing for which the generatrix is vertical and an impeller disposed to rotate within said housing about a vertical axis for passing air through said evaporator heat exchanger, said vertical axes of said first blower, said impeller and said compressor all being spaced horizontally from each other and all being spaced horizontally from said vertical faces of said condenser and evaporator heat exchangers, and said vertical faces of said condenser and said evaporator heat exchangers being spaced horizontally from each other.

5. Refrigeration apparatus comprising: an air-cooled refrigerant condensing section having a generally rectangular pan-like frame, an air-cooled refrigerant condenser heat exchanger disposed on said frame and having a plurality of substantially vertical faces adjacent plural margins of said pan-like frame; and a refrigerant evaporator section abutting said condenser section at one of said plurality of vertical faces of said condenser heat exchanger and having a housing including sidewalls and a generally rectangular bottom wall, a refrigerant evaporator heat exchanger disposed within said housing, a first of said sidewalls being generally parallel to one edge of said rectangular bottom and being provided with air inlet and outlet openings to conduct air to and from said evaporator heat exchanger, a second of said sidewalls disposed opposite said first sidewall having a first portion disposed a relatively greater distance from said first sidewall than a second portion thereof, said second portion of said second sidewall being disposed in face-to-face spaced relationship with said one face of said condenser heat exchanger to thereby define an air conducting channel to said one face of said condenser heat exchanger, and a centrifugal evaporator blower disposed between said one portion of said second sidewall and said first sidewall for passing air from said inlet opening over said evaporator heat exchanger to said outlet opening.

6. Air conditioning apparatus comprising: an evaporator section including a unit housing having top, bottom, and sidewalls, an evaporator heat exchanger disposed within said unit housing, inlet and outlet openings in sidewalls of said unit housing disposed in horizontal side-by-side relationship, a centrifugal blower within said unit housing having a cylindrical housing for which the generatrix is generally vertical and an impeller wheel within said blower housing disposed to rotate about a vertical axis, said evaporator heat exchanger being positioned in a fluid path between said inlet opening of said unit housing and said inlet opening of said blower housing.

7. The apparatus as defined by claim 6 wherein said bottom wall is generally rectangular and said inlet and outlet opening are disposed in a common plane generally parallel to one edge of said bottom wall and said blower housing extending into the space defined by said blower inlet opening projected inwardly of said unit housing normally of said common plane.

\* \* \* \* \*

60

65

70

75