



US00D795883S

(12) **United States Design Patent**
Aoshima

(10) **Patent No.:** **US D795,883 S**

(45) **Date of Patent:** **** Aug. 29, 2017**

(54) **TRANSITIONAL IMAGE FOR PORTION OF DISPLAY SCREEN FOR DIGITAL CAMERA**

(71) Applicant: **FUJIFILM CORPORATION**,
Minato-ku, Tokyo (JP)

(72) Inventor: **Yuzo Aoshima**, Minato-ku (JP)

(73) Assignee: **FUJIFILM Corporation**, Minato-ku,
Tokyo (JP)

(**) Term: **14 Years**

(21) Appl. No.: **29/455,383**

(22) Filed: **May 20, 2013**

(30) **Foreign Application Priority Data**

Nov. 30, 2012 (JP) 2012-029373

Nov. 30, 2012 (JP) 2012-029375

(Continued)

(51) **LOC (10) Cl.** **14-04**

(52) **U.S. Cl.** **D14/485**

USPC **D14/485**

(Continued)

(58) **Field of Classification Search**

USPC D14/485-495; 715/700-867, 973-977

(Continued)

(56) **References Cited**

U.S. PATENT DOCUMENTS

D588,152 S * 3/2009 Okada D14/488

D588,153 S * 3/2009 Okada D14/488

(Continued)

Primary Examiner — Richard E Chilcot

(74) *Attorney, Agent, or Firm* — Sughrue Mion, PLLC

(57) **CLAIM**

The ornamental design for a transitional image for portion of display screen for digital camera, as shown and described.

DESCRIPTION

The patent or application file contains at least one drawing executed in color. Copies of this patent or patent application

publication with color drawing(s) will be provided by the Office upon request and payment of the necessary fee.

FIG. 1 is a front elevational view of a digital camera having a display screen showing my new design;

FIG. 2 is a top plan view thereof;

FIG. 3 is a bottom plan view thereof;

FIG. 4 is a left side elevational view thereof;

FIG. 5 is a right side elevational view thereof;

FIG. 6 is a rear elevational view thereof, showing a display screen of a first embodiment;

FIG. 7 is an enlarged view of the display screen of the first embodiment;

FIG. 8 is an enlarged view of the display screen of the first embodiment in use, in which a taking lens is in an out-of-focus state;

FIG. 9 is an enlarged view of the display screen of the first embodiment in use, in which the taking lens is in an in-focus state;

FIG. 10 is a picture of the display screen of the first embodiment actually in use, in which the taking lens is in an out-of-focus state;

FIG. 11 is a picture of the display screen of the first embodiment actually in use, in which the taking lens is in an in-focus state;

FIG. 12 is a rear elevational view of a digital camera having a display screen of a second embodiment;

FIG. 13 is an enlarged view of the display screen of the second embodiment, in which a taking lens is in an out-of-focus state;

FIG. 14 is an enlarged view of the display screen of the second embodiment, in which the taking lens is in an in-focus state, and a borderline between sub-areas is invisible;

FIG. 15 is an enlarged view of the display screen of the second embodiment in use, in which the taking lens is in an out-of-focus state;

FIG. 16 is an enlarged view of the display screen of the second embodiment in use, in which the taking lens is in an in-focus state;

FIG. 17 is a picture of the display screen of the second embodiment actually in use, in which the taking lens is in an out-of-focus state;

(Continued)

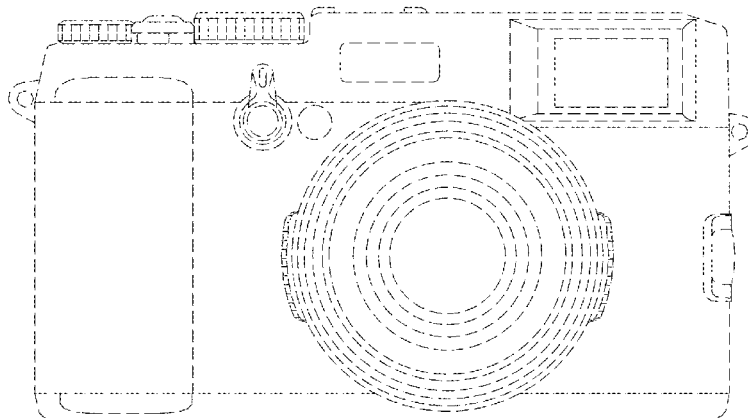

FIG. 18 is a picture of the display screen of the second embodiment actually in use, in which the taking lens is in an in-focus state;

FIG. 19 is a rear elevational view of a digital camera having a display screen of a third embodiment;

FIG. 20 is an enlarged view of the display screen of the third embodiment, in which a taking lens is in an out-of-focus state;

FIG. 21 is an enlarged view of the display screen of the third embodiment, in which the taking lens is in an in-focus state, and a borderline between sub-areas is invisible;

FIG. 22 is an enlarged view of the display screen of the third embodiment in use, in which the taking lens is in an out-of-focus state;

FIG. 23 is an enlarged view of the display screen of the third embodiment in use, in which the taking lens is in an in-focus state;

FIG. 24 is a picture of the display screen of the third embodiment actually in use, in which the taking lens is in an out-of-focus state;

FIG. 25 is a picture of the display screen of the third embodiment actually in use, in which the taking lens is in an in-focus state;

FIG. 26 is a rear elevational view of a digital camera having a display screen of a fourth embodiment;

FIG. 27 is an enlarged view of the display screen of the fourth embodiment, in which a taking lens is in an out-of-focus state;

FIG. 28 is an enlarged view of the display screen of the fourth embodiment, in which the taking lens is in an in-focus state, and a borderline between sub-areas is invisible;

FIG. 29 is an enlarged view of the display screen of the fourth embodiment in use, in which a taking lens is in an out-of-focus state;

FIG. 30 is an enlarged view of the display screen of the fourth embodiment in use, in which the taking lens is in an in-focus state;

FIG. 31 is a picture of the display screen of the fourth embodiment actually in use, in which the taking lens is in an out-of-focus state; and,

FIG. 32 is a picture of the display screen of the fourth embodiment actually in use, in which the taking lens is in an in-focus state.

The portions of the display screen for digital camera in broken lines are shown for illustrative purposes only and form no part of the claimed design.

**1 Claim, 18 Drawing Sheets
(4 of 18 Drawing Sheet(s) Filed in Color)**

(30) **Foreign Application Priority Data**

Nov. 30, 2012 (JP) 2012-029386
Nov. 30, 2012 (JP) 2012-029388

(52) **U.S. Cl.**
CPC *G06F 3/04817* (2013.01)

(58) **Field of Classification Search**
CPC G06F 3/0481-3/0486
See application file for complete search history.

(56) **References Cited**

U.S. PATENT DOCUMENTS

D600,701 S *	9/2009	Kase	D14/486
D609,714 S *	2/2010	Oda	D14/485
7,697,025 B2 *	4/2010	Hasegawa	H04N 5/23216 348/135
D642,184 S *	7/2011	Brouwers	D14/486
D645,875 S *	9/2011	Cavanaugh	D14/488
D675,241 S *	1/2013	Oda	D14/486
D684,162 S *	6/2013	Aoshima	D14/485
D689,904 S *	9/2013	Aoshima	D14/489
D700,193 S *	2/2014	Oda	D14/485
D715,828 S *	10/2014	Aoshima	D14/488
D715,829 S *	10/2014	Aoshima	D14/488
D731,543 S *	6/2015	Aoshima	D14/489
D734,357 S *	7/2015	Myoung	D14/488
D738,895 S *	9/2015	Myoung	D14/486

* cited by examiner

FIG. 1

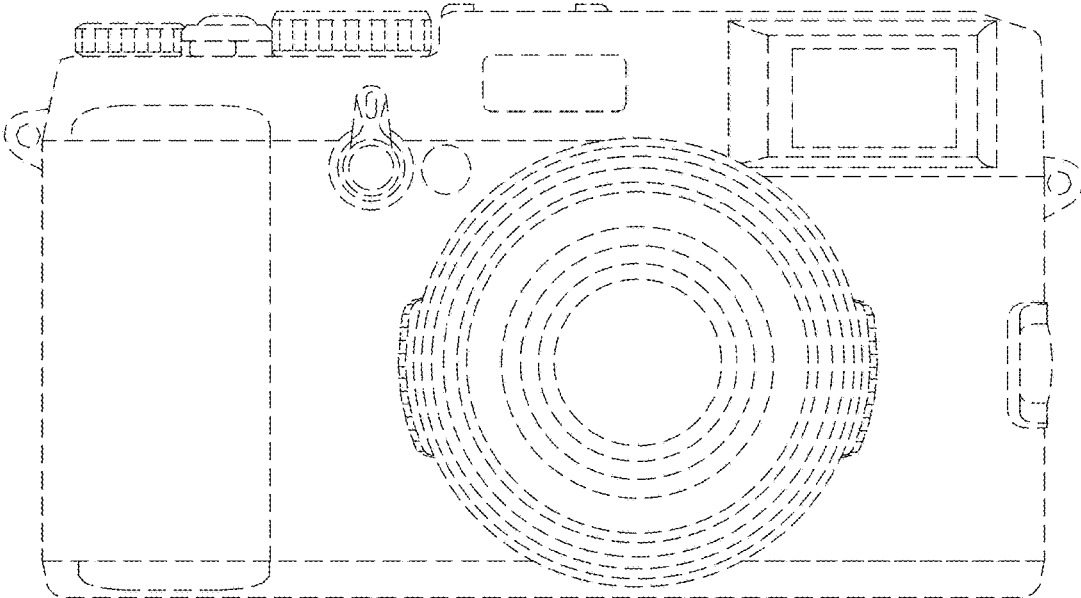

FIG. 2

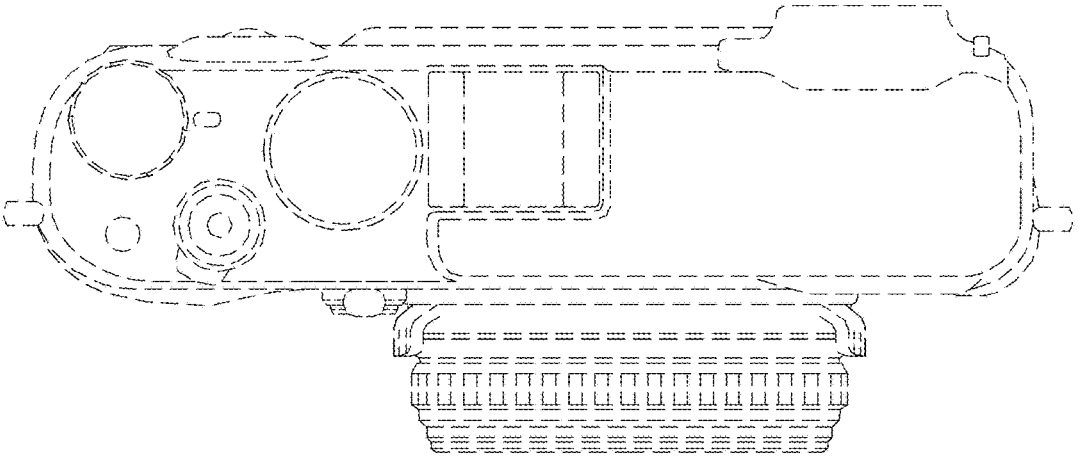

FIG. 3

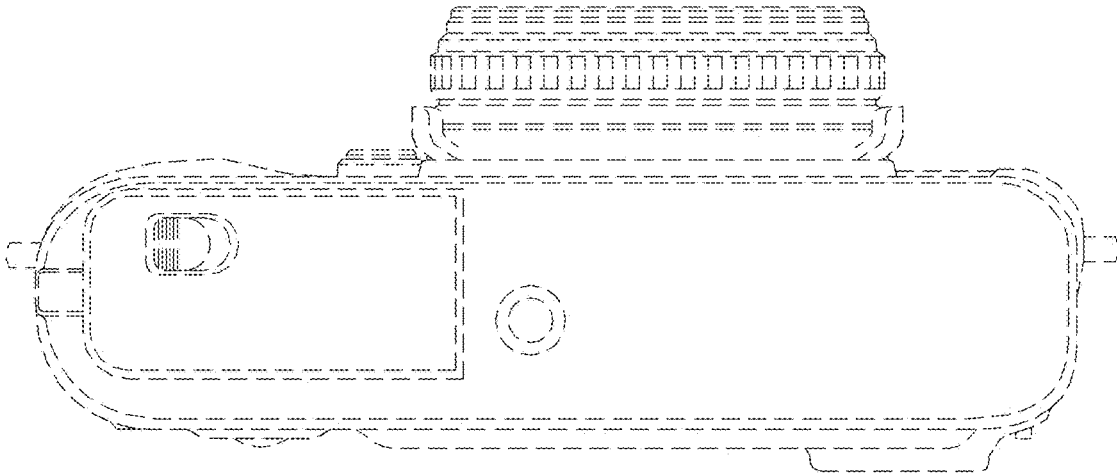
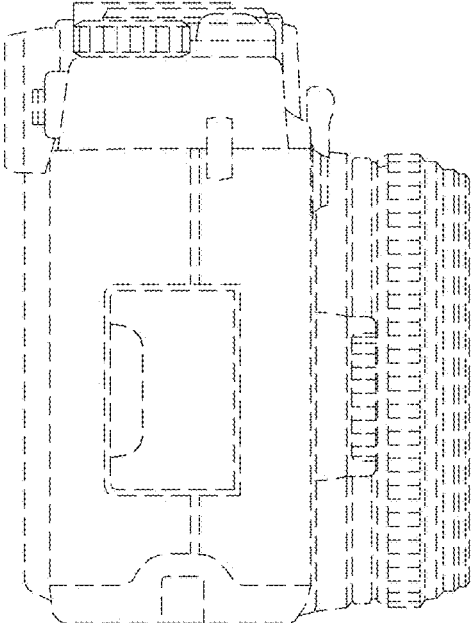
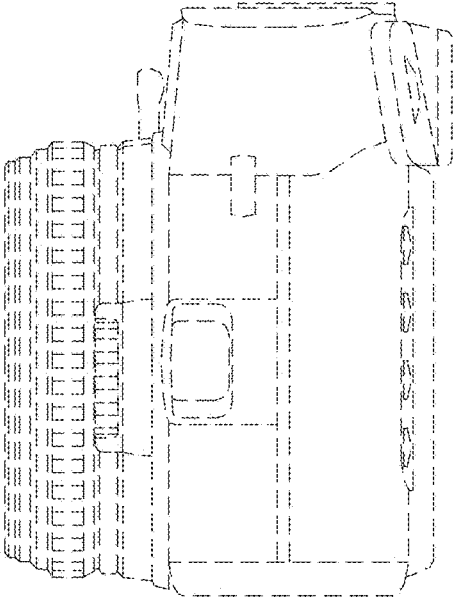

FIG. 4



F I G . 5



F I G . 6

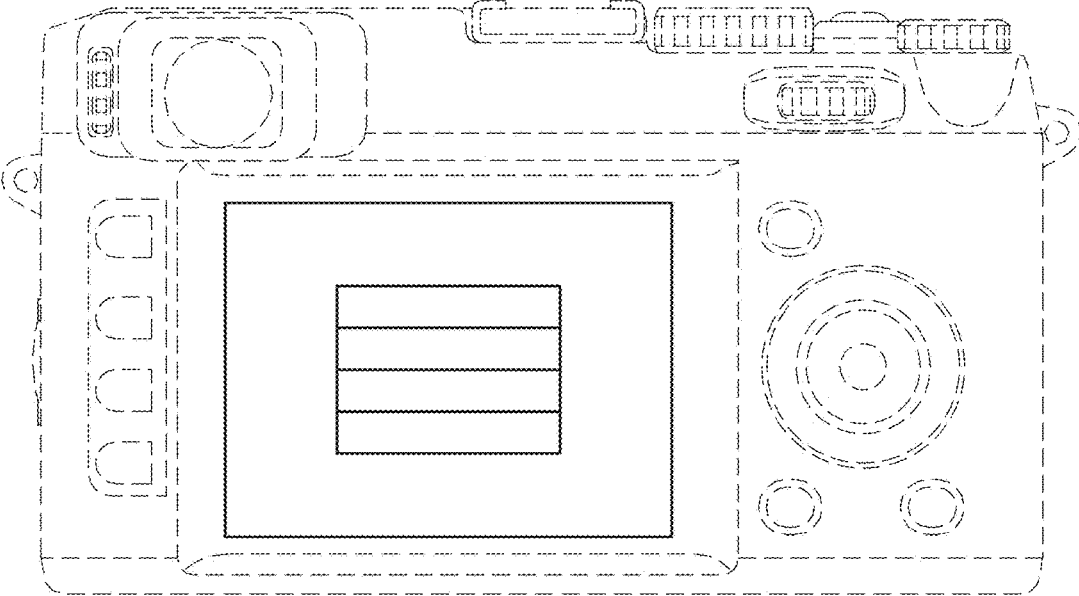

FIG. 7

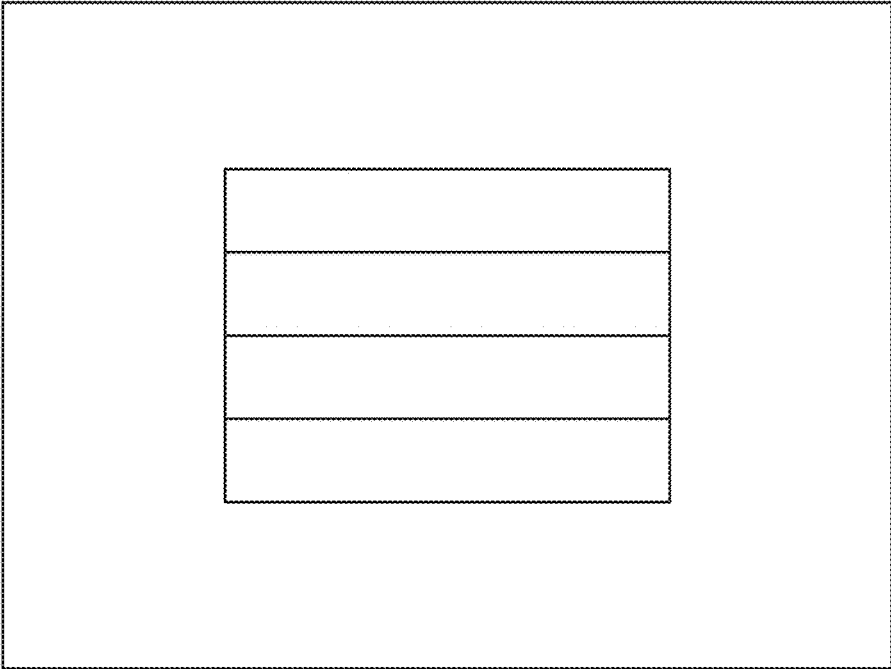

FIG. 8

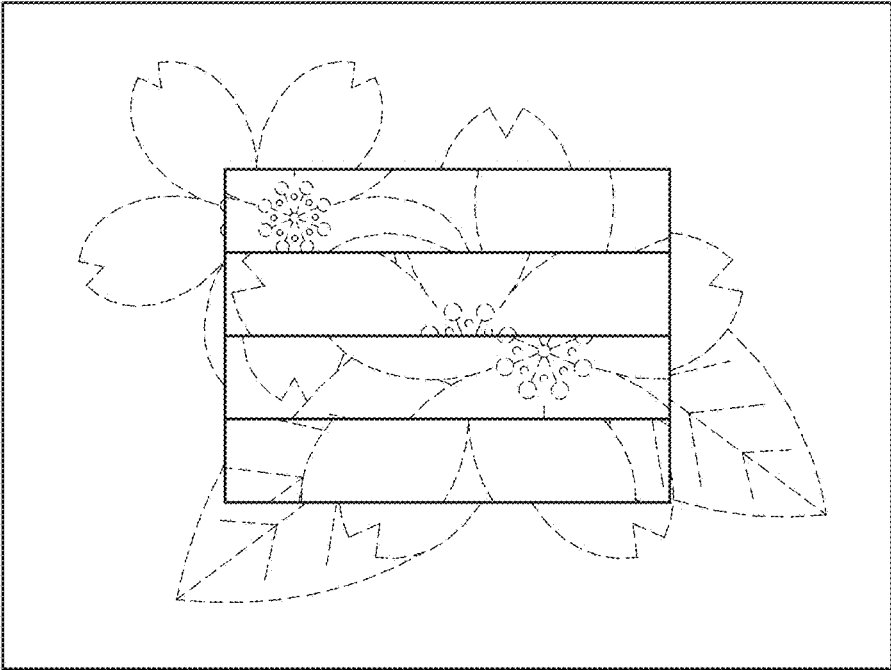

FIG. 9

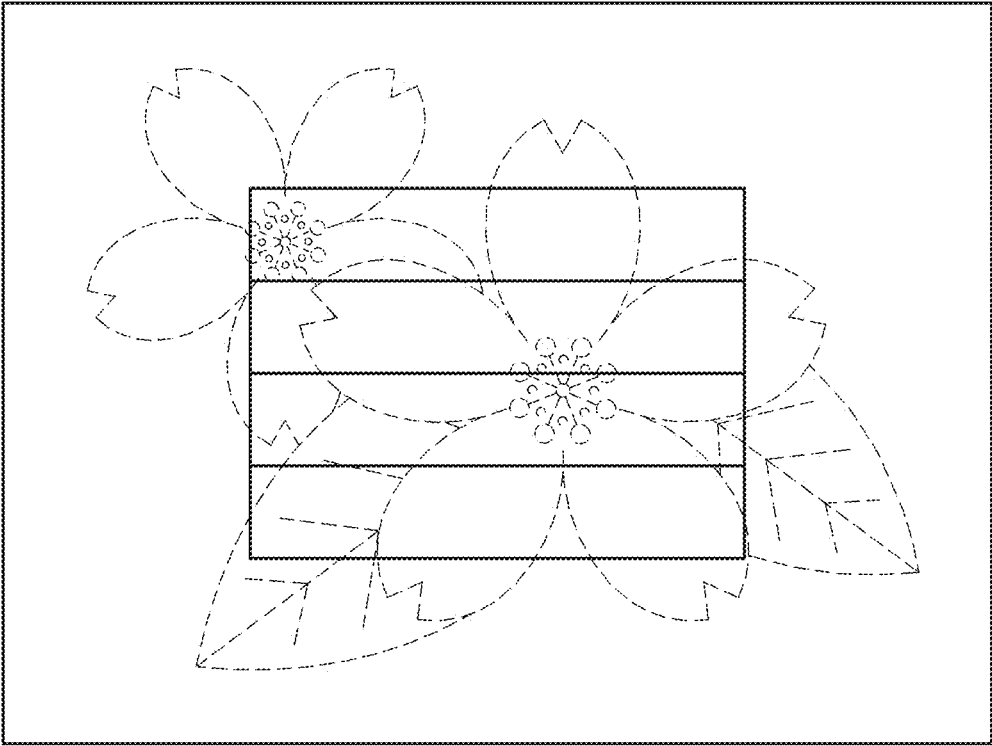

FIG. 10



FIG. 11



FIG. 12

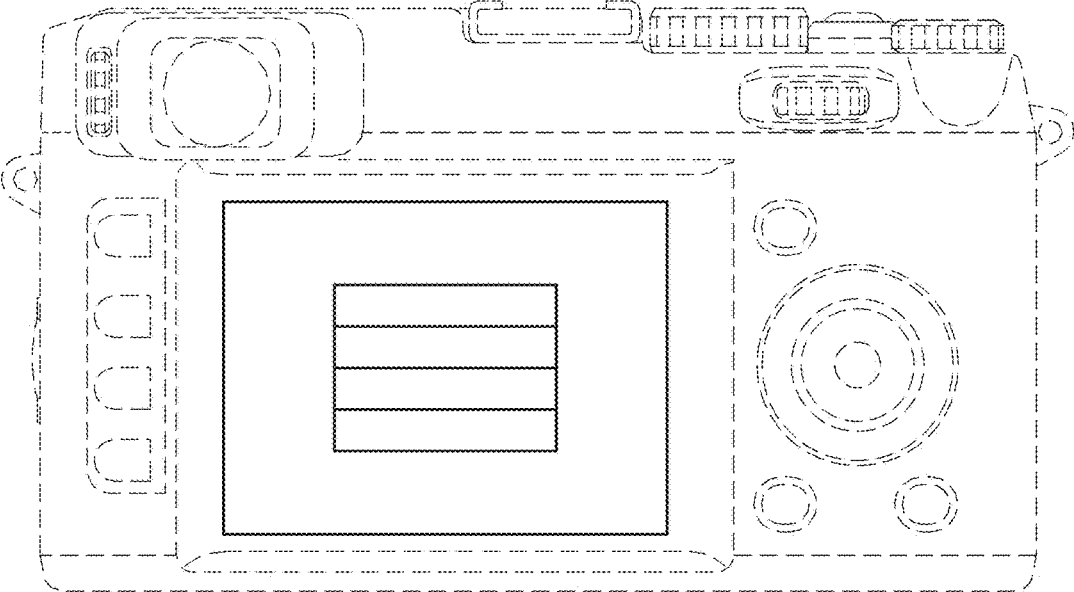

FIG. 13

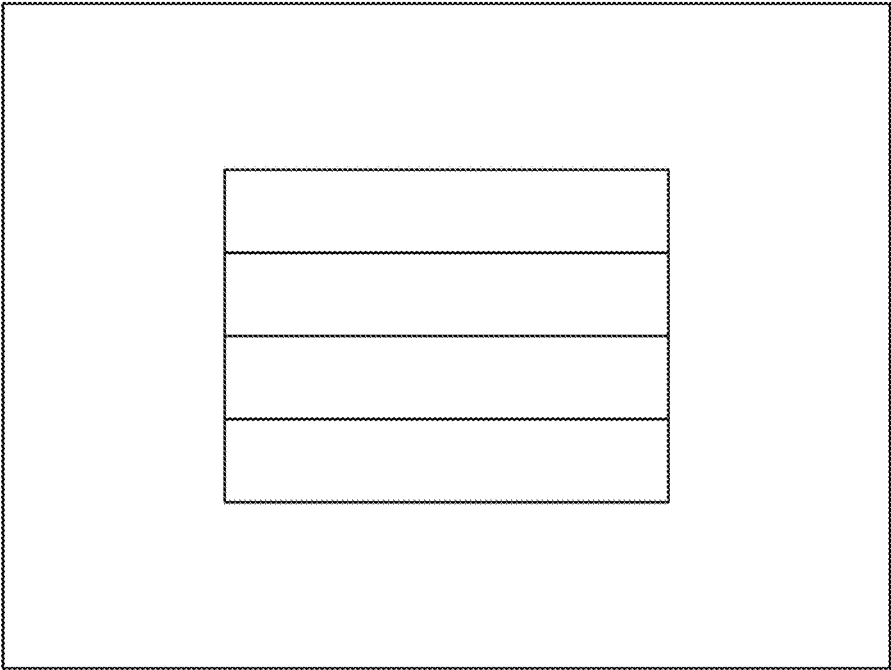

FIG. 14

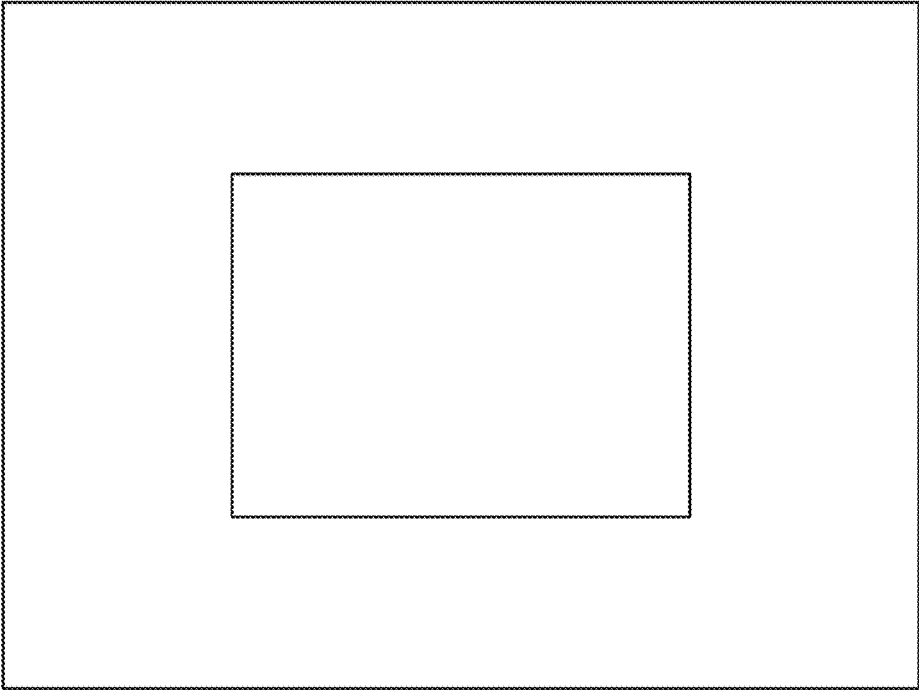

FIG. 15

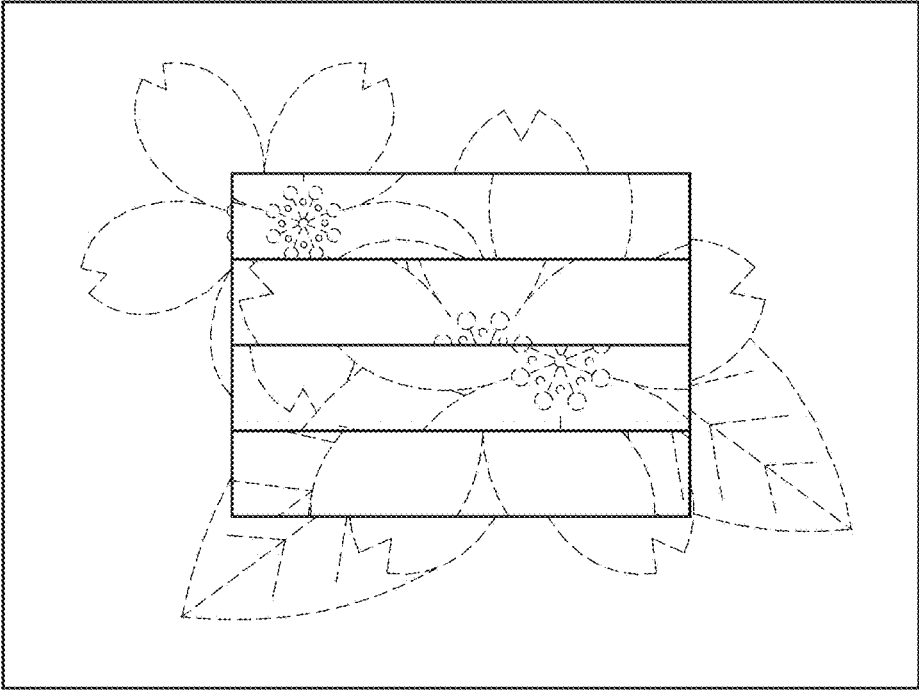

FIG. 16

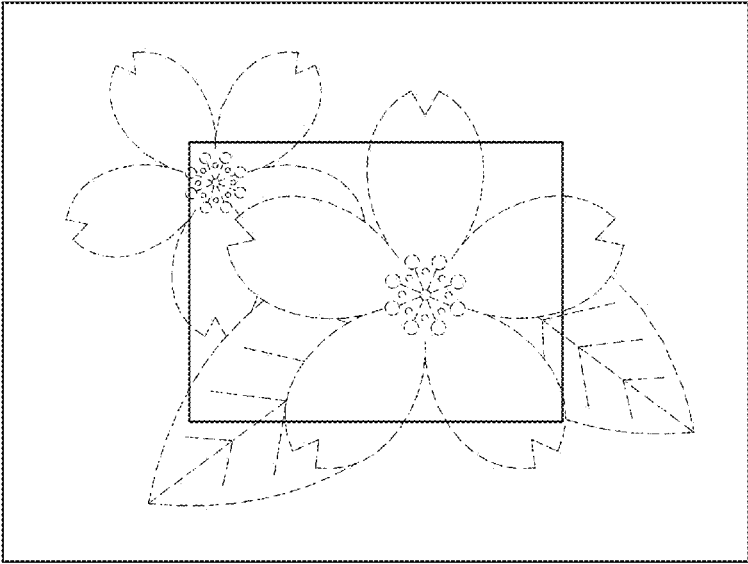

FIG. 17



FIG. 18



FIG. 19

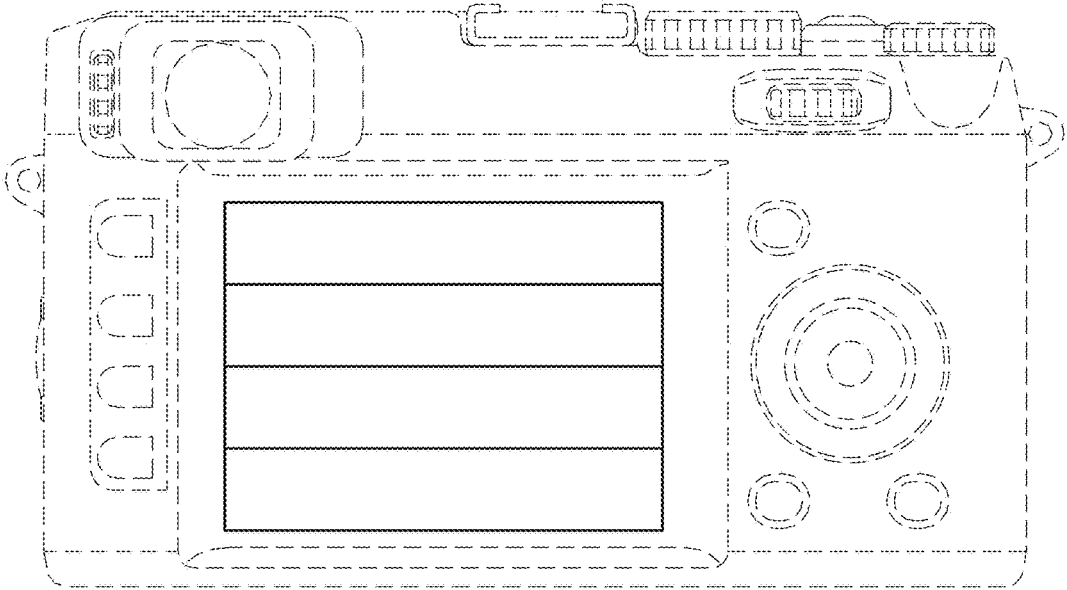

FIG. 20

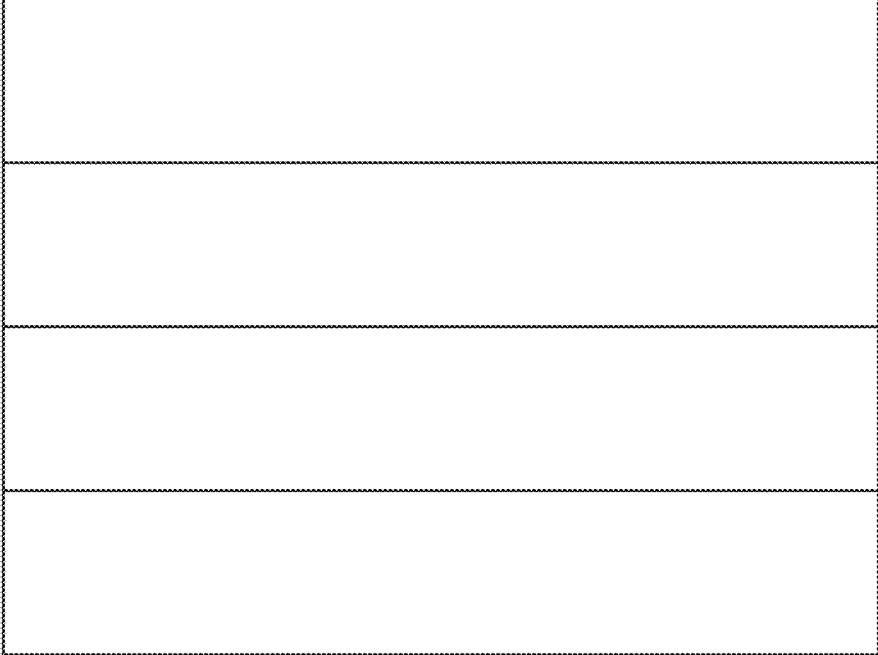

FIG. 21

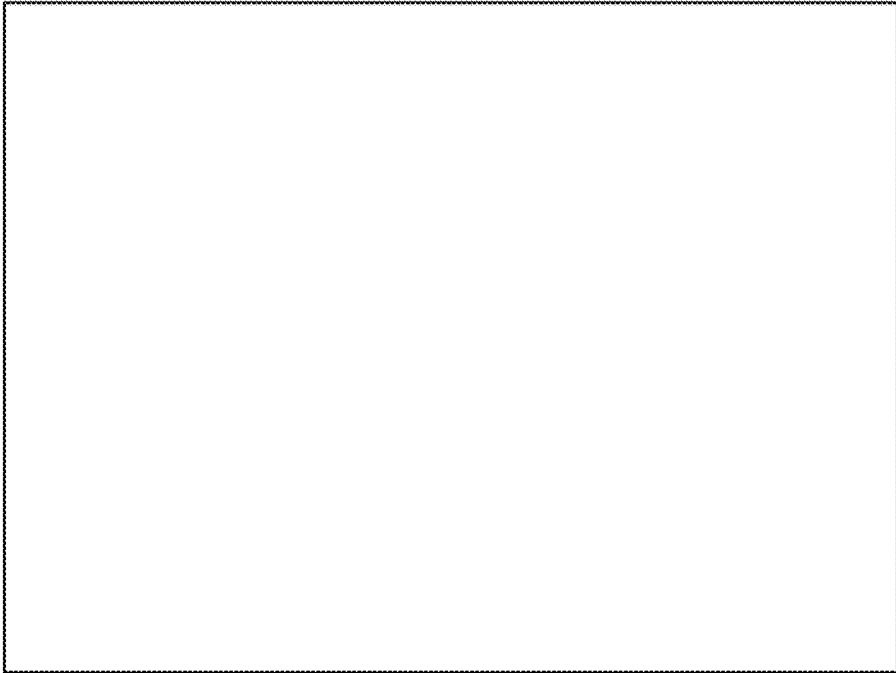

FIG. 22

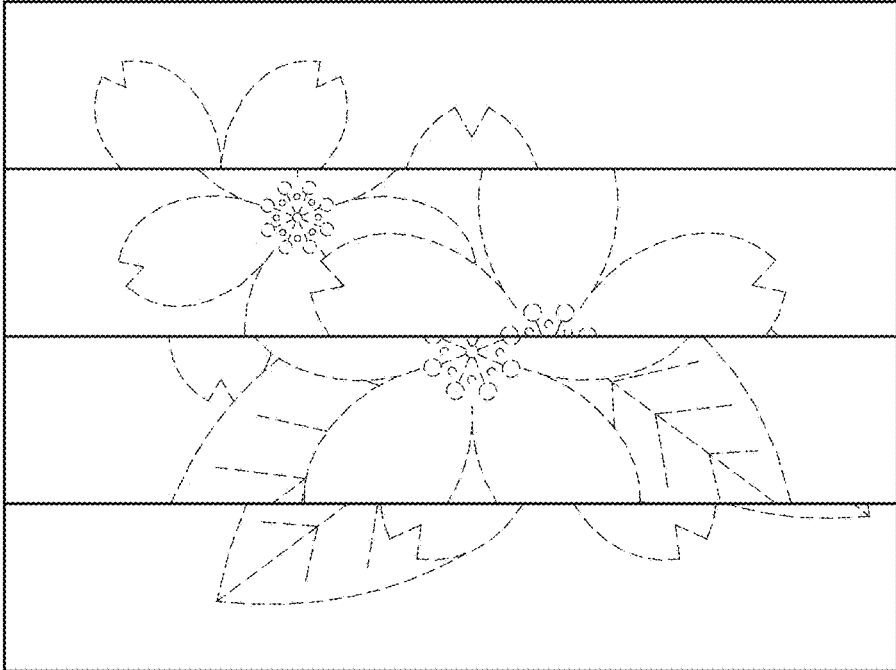

FIG. 23

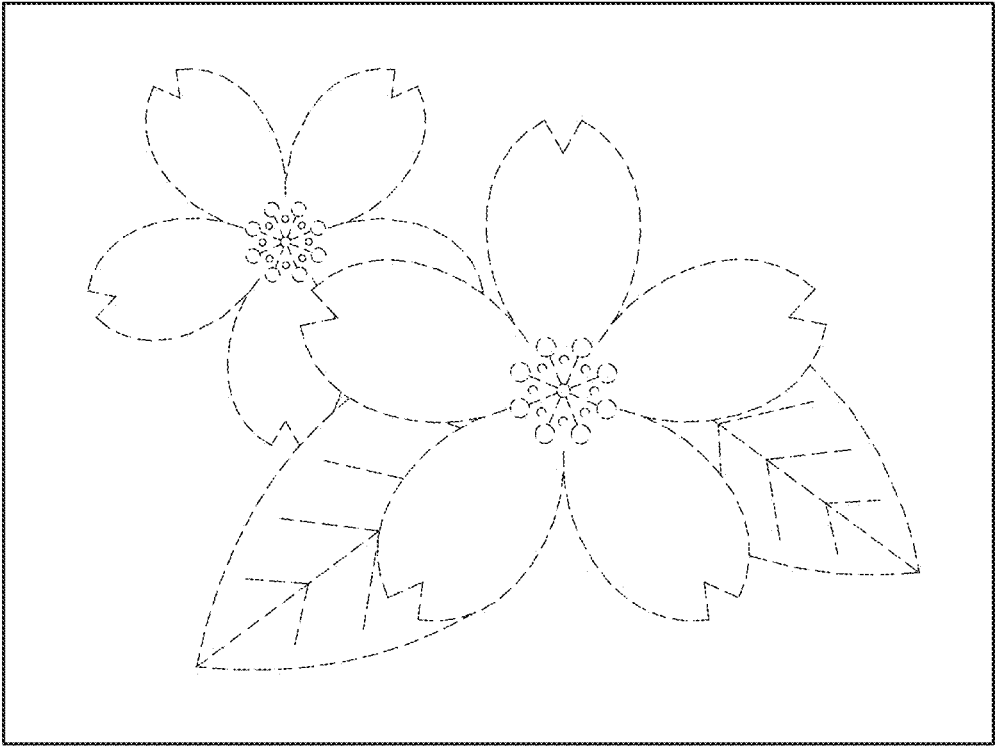

FIG. 24



FIG. 25



FIG. 26

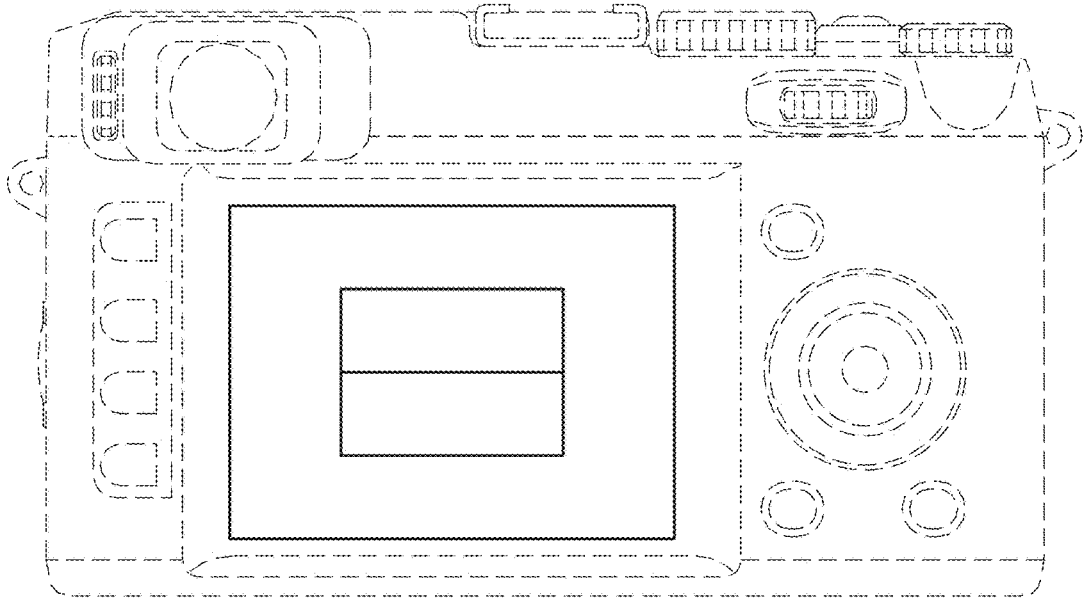
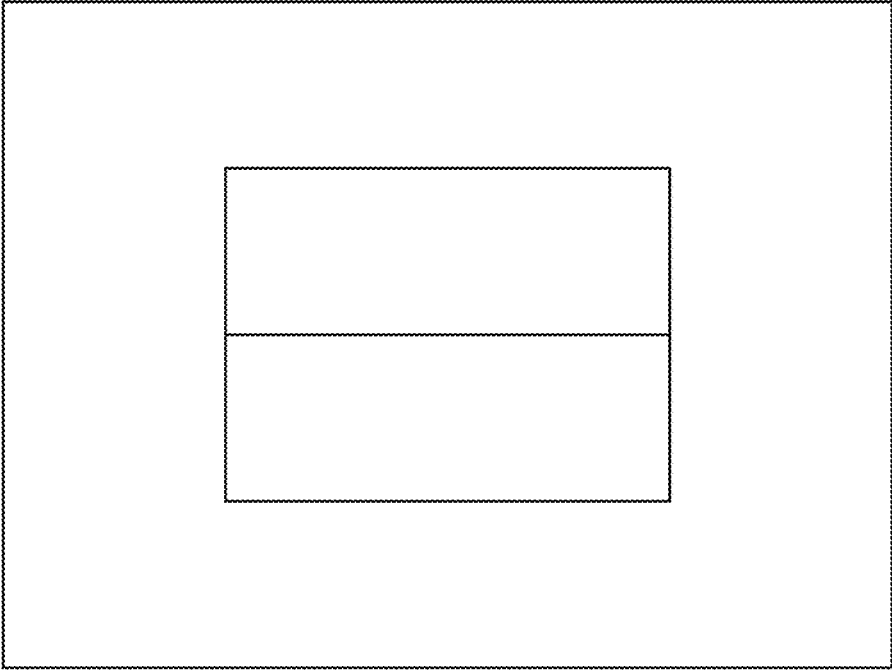
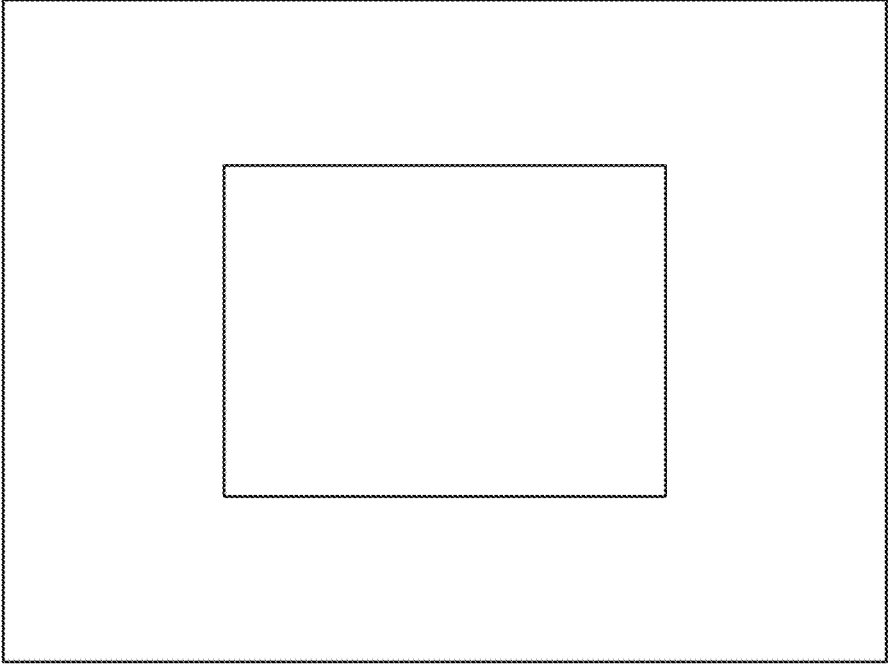

FIG. 27



F I G . 2 8



F I G . 2 9

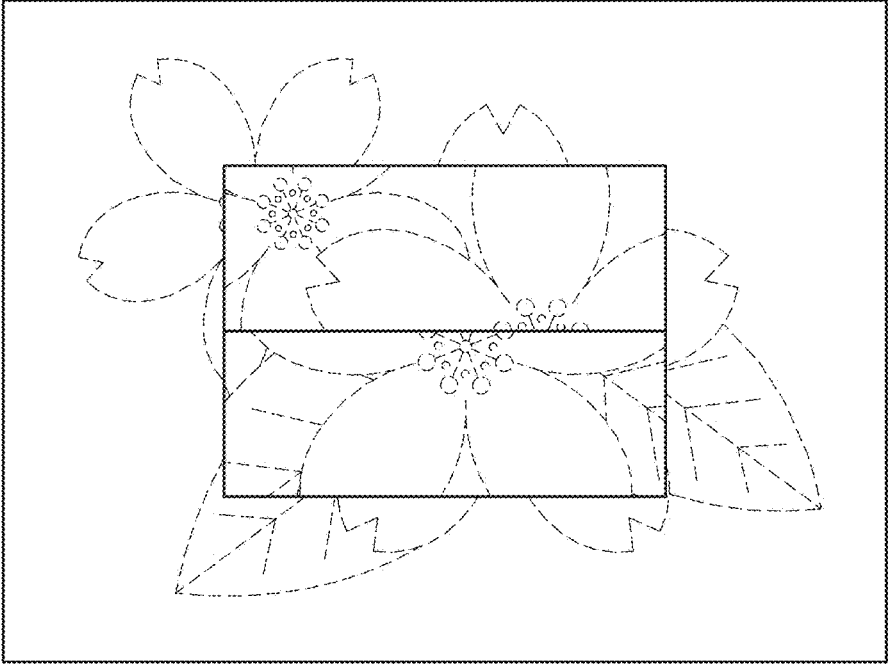

FIG. 30

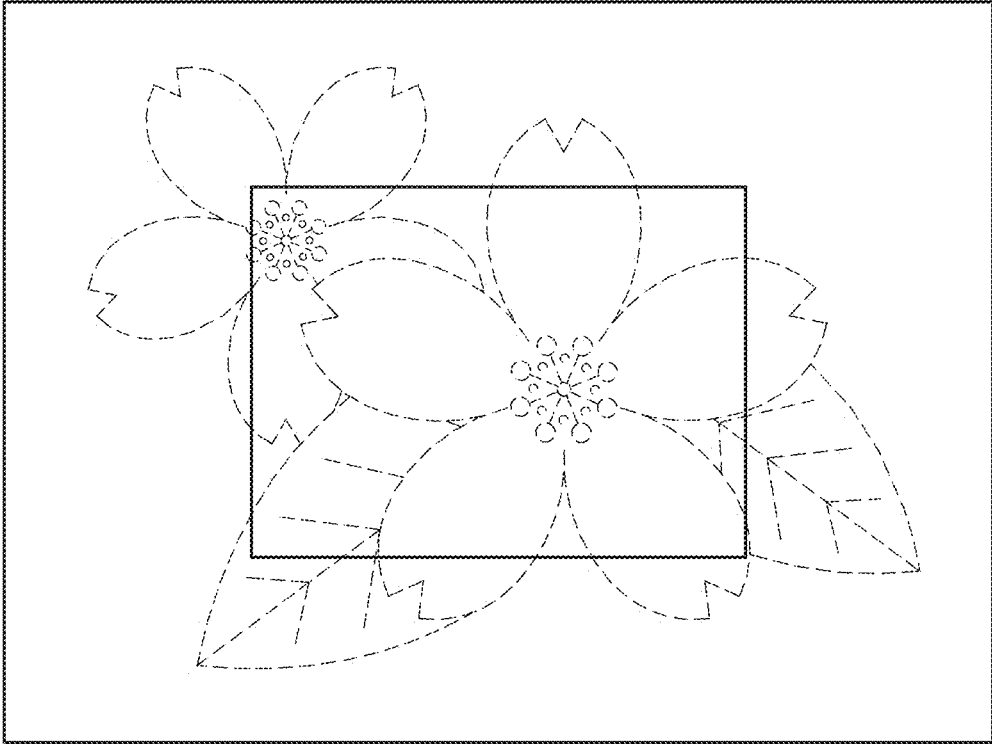

FIG. 31



FIG. 32

