

United States Patent

[11] 3,618,594

[72] Inventor **Anton Banko**  
 Brooklyn, N.Y.  
 [21] Appl. No. **25,991**  
 [22] Filed **Apr. 6, 1970**  
 [23] Division of Ser. No. 760,003, Sept. 16, 1968,  
 Pat. No. 3,528,410.  
 [45] Patented **Nov. 9, 1971**  
 [73] Assignee **Surgical Design Corporation**  
 Queens, N.Y.

[51] Int. Cl. .... **A61h 1/00,**  
**A61f 9/00**  
 [50] Field of Search ..... **128/24 A,**  
**303, 334 R, 335**

[56] **References Cited**  
**UNITED STATES PATENTS**  
 2,917,042 12/1959 Brown et al. .... **128/24 A**  
 2,968,302 1/1961 Fry et al. .... **128/24 A**  
 3,213,537 10/1965 Balamuth et al. .... **128/24 A UX**

*Primary Examiner*—Channing L. Pace  
*Attorney*—Darby & Darby

[54] **ULTRASONIC APPARATUS FOR RETINAL REATTACHMENT**  
**11 Claims, 8 Drawing Figs.**

[52] U.S. Cl. .... **128/24 A,**  
**128/303**

**ABSTRACT:** The method and apparatus relate to performing surgical operations on the eye in vivo, including retina reattachment by the insertion of an ultrasonic probe within the eye.

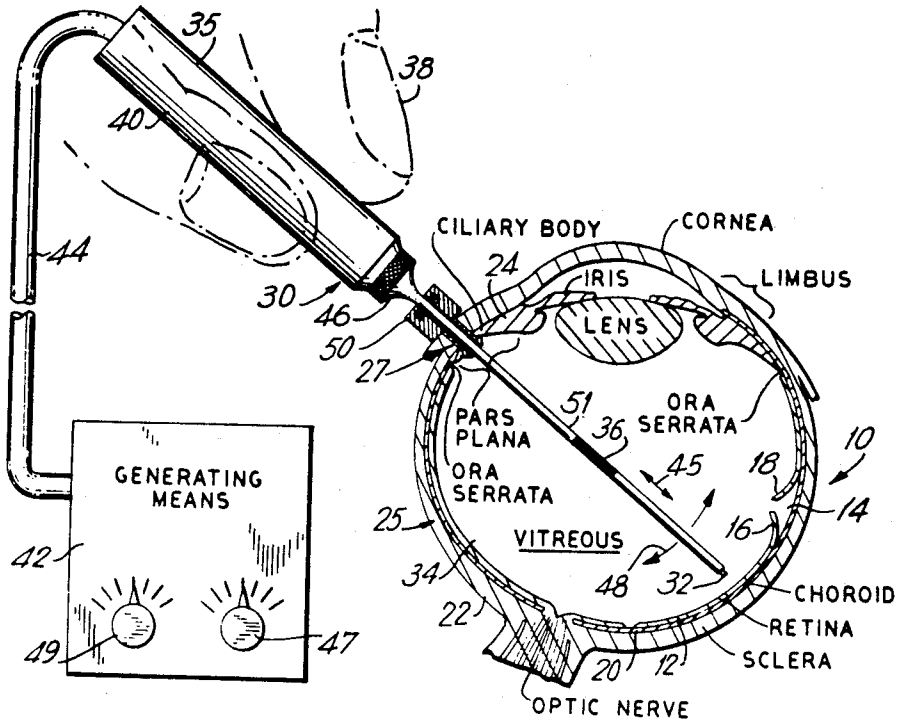

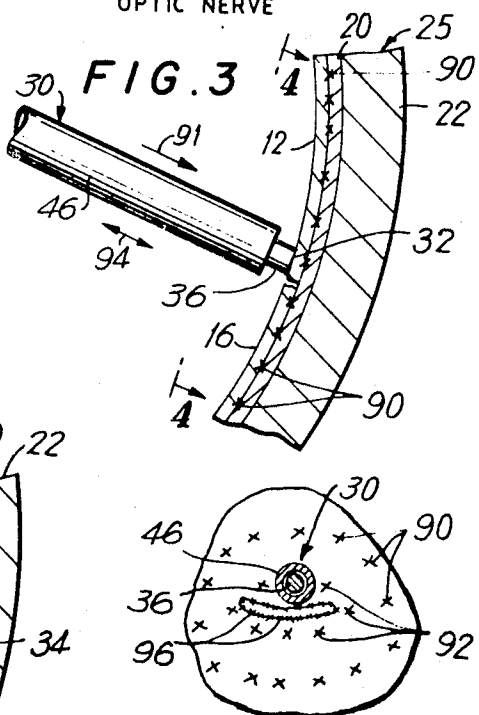
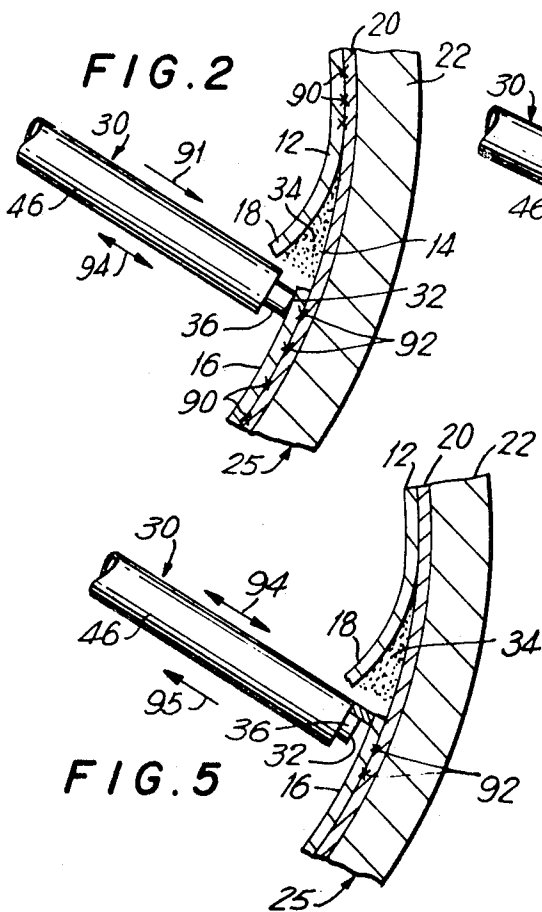
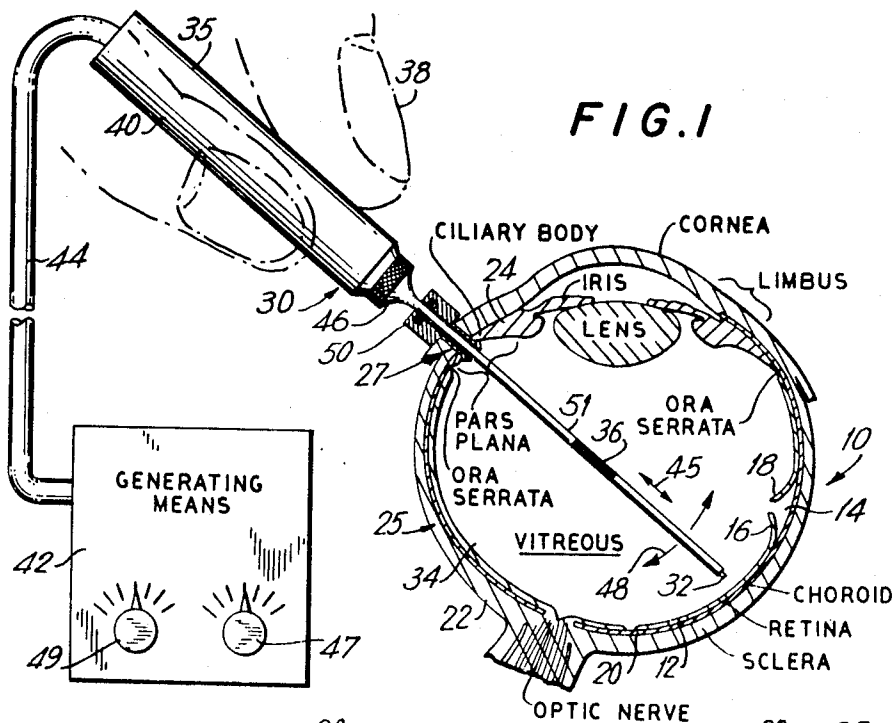
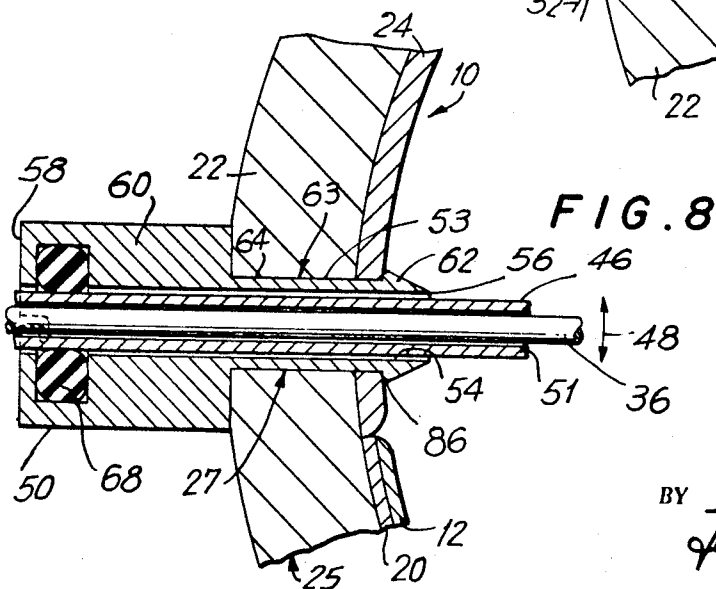
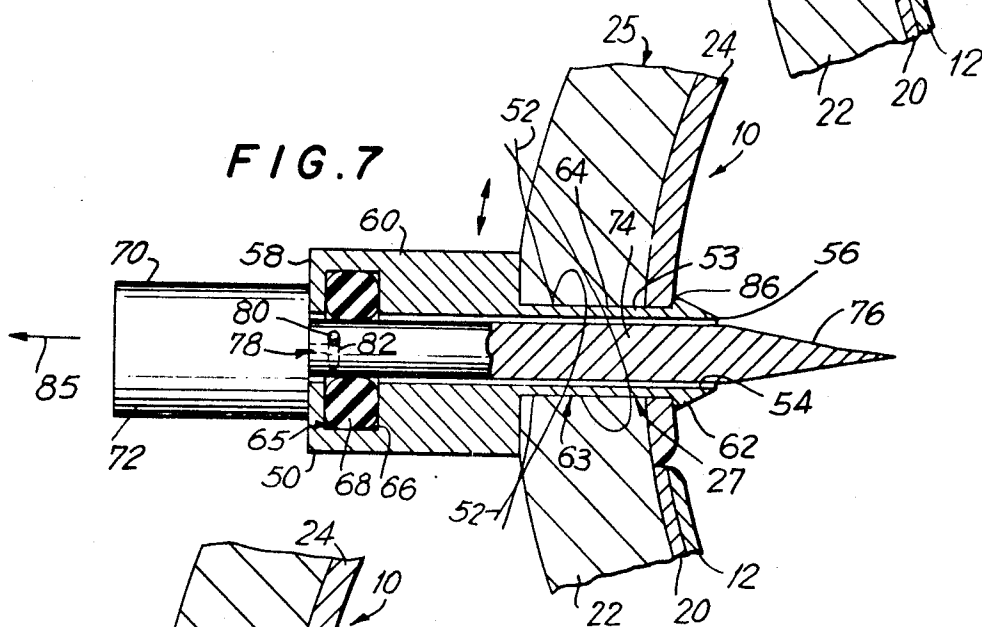
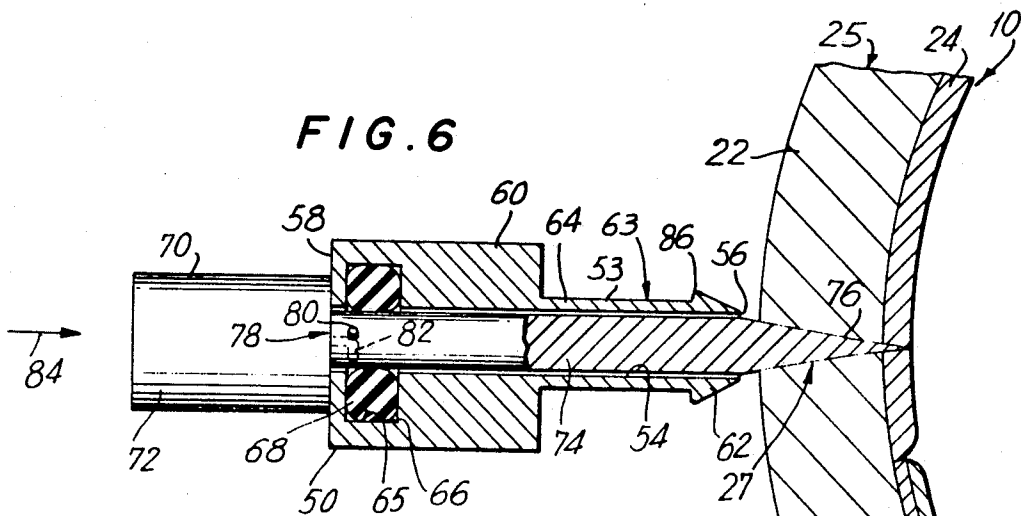

FIG. 4

INVENTOR.  
ANTON BANKO

BY *Leonard W. Suroff*  
ATTORNEY



INVENTOR.  
ANTON BANKO

BY *Leonard W. Anoff*  
ATTORNEY

## ULTRASONIC APPARATUS FOR RETINAL REATTACHMENT

### CROSS-REFERENCE TO RELATED APPLICATION

This is a division of application Ser. No. 760,003, filed Sept. 16, 1968, now Pat. No. 3,528,410, dated Sept. 15, 1970.

In applicant's copending application Ser. No. 762,286, filed on Sept. 16, 1968, and which entire subject matter of the copending application is incorporated herein by reference as if fully set forth herein, applicant discloses the method and apparatus for forming an opening or incision in the eye and the performing of surgical procedures.

### BACKGROUND OF THE INVENTION

The present invention relates generally to improvements in surgical procedures related to the eye, and more particularly for using ultrasonic energy waves to perform retina reattachment and treatment procedures.

The outstanding and unexpected results obtained by the practice of the method and apparatus of the present invention are attained by a series of features, steps and elements, working together in interrelated combination, and may be applied to biological organisms in general and particularly humans, and hence will be so illustrated and described.

Before proceeding to the details of the invention, let us first review briefly generally known facts of the eye and the anatomy of the retina. The retina of the eye is attached to the underlying choroid at the optic nerve border posteriorly and at the ora serrata anteriorly. Between these two points it is in contact with but not attached to the choroid. The retina covers entire inner aspect of the eyeball posterior to the ora serrata. The ora serrata is the junction of the retina and the ciliary body, in the average eye it is about 8 mm. posterior to the limbus. The retina is composed of inelastic nerve tissue, consisting of 10 distinct different layers. Normally it is transparent; when detached it appears gray. Most common of retina detachment is the partial separation (detachment) of the retina from the choroid. The superior temporal part of the retina is most commonly affected, but any part or even the entire retina may become detached.

Reattachment of the retina can be accomplished only by surgery. To date essentially four different approaches are presently being used on humans to obtain this reattachment. In one of these a partially penetrating diathermy electrode is passed through the area of the sclera which corresponds to the retinal defects. The subretinal fluid is then drained by perforating the sclera and choroid. Drainage of the subretinal fluid is important so that the retina can settle back against the choroid. In a few weeks a cicatricial bond is formed; it involves the retina, choroid and sclera.

Cryosurgery is another approach used in the same way as diathermy. The supercool probe causes a chorioretinal scar with minimal scleral damage, making the operation less hazardous.

The photocoagulation process is one in which a small choroidal retinal inflammatory exudate is produced by directing a strong light from a carbon arc source through the dilated pupil. This treatment is used in minimal detachments and postoperatively to supplement inadequate diathermy.

Laser energy (light amplification by stimulated emission of radiation) is a form of photocoagulation that is used less frequently than carbon arc photocoagulation, but has been used on humans.

The use of ultrasonic energy has also been proposed for retina reattachment in which the energy is transmitted from the exterior of the eye for retina reattachment. In one procedure chorioretinal lesions were produced with a focused sound beam which entered the eye anterior to the equator. Frequencies in the megahertz range were used. In addition 25,000 cycle per second energy has been applied by pressing the tip of the probe against the sclera in the region where a lesion on the retina is desired. At 25,000 cycles per second chorioretinal lesions can be produced by a 1.5 mm. diameter tip

vibrating with a stroke of 50 microns (0.002) for several seconds, scleral damage is unavoidable.

### OBJECTIVES OF THE INVENTION

5 An object of the present invention is to provide an improved method and apparatus for performing surgical procedures with respect to the eye.

10 Another object of the present invention is to provide an improved method and apparatus which utilizes ultrasonic energy for performing surgical procedures.

Another object of the present invention is to provide an improved method and apparatus for performing surgical procedures in vivo in the eye.

15 Another object of the present invention is to provide an improved method and apparatus for performing reattachment of the retina by employing ultrasonic energy introduced within the eye in vivo.

20 Another object of the present invention is to provide an improved method and apparatus using ultrasonic energy for securing together layers of tissue in biological organisms, such as the retina to the choroid.

25 Another object of the present invention is to provide specially designed instrumentation to carry out the surgical procedures of the present invention.

Other objects and advantages of this invention will become apparent as the disclosure proceeds.

### SUMMARY OF THE INVENTION

30 The present invention is directed to the treatment of the eye and is based upon the discovery that the retina reattachment may be accomplished by inserting an ultrasonic probe within the eye and propagating the energy waves directly to the detached portions. Accordingly, the front part of the ultrasonic probe is inserted into the eye through a sclerotomy over the pars plana opposite to the retinal defect. The sclerotomy will be bridged with a preplaced mattress suture of which the tightening will prevent vitreous loss during operation. The tip of the ultrasonic probe can be positioned in the desired region, in the proximity or adjacent to the retina, by a micromanipulator. The amount of ultrasonic energy emitted by the tip, vibrating at a given frequency, is proportional to the vibratory stroke of motion and the number of cycles of vibration (time of vibration). Both factors are precisely controlled. The amount of ultrasonic radiation is limited to produce small choroidal retinal inflammatory irritation, sufficient to form a delicate weldlike bond between the retina and choroid, but insufficient to create an explicit lesion. The sclera is not considerably effected by this procedure.

45 Unlike diathermy and the cryo probe the tip of the ultrasonic probe remains practically at the same temperature, whether it vibrates or not, it is for this reason that any transfer of any kind of energy practically ceases as the tip stops to vibrate.

50 The above-mentioned sclerotomy may be formed in accordance with applicant's copending patent application hereinabove referred to, and may be used for insertion of other tools and instruments beside the ultrasonic probe. Some of which may by way of illustration, a two-way bundle of fibers, of which one set is used for the illumination of the interior of the eye and the other set in the bundle is used to carry the image back to the viewer. This arrangement enables a thorough inspection of the interior of the eye before and after the operation.

55 The present invention is based on the discovery that the detached retina portion may be joined by utilizing vibrational wave energy that is introduced within the eye cavity in small amounts and dosages. The joinder of the detached portion is accomplished without necessarily employing radical surgical procedures related to high intensity or high-power ultrasonic energy and in this manner serves to reduce any side effects or secondary results which would be dangerous to the patient. As is well known, by transmitting the energy through sclera and

choroid, there is a possibility of doing damage to tissues adjacent to the probe. Further, by introducing energy of a magnitude greater than is required to perform the bond (because of the attenuation through sclera and choroid), other portions of the organ may also be adversely affected.

The present invention accomplishes the beneficial results by the direct application of sonic, transonic or ultrasonic vibrational wave energy directly within the eye and only to the particular detached portion thereof at its location. In this manner the detached portion of the retina can be completely secured in place by the direct application of tolerable amounts of energy for short periods of time and, in particular, times which are so short that the heating effects normally associated with the application of concentrated wave energy to the human body do not present a significant problem. It has been found that the detached portions may be joined together without any damage to sclera or other tissue in other regions of the eye, and without introducing major amounts of energy. Unlike in other standard procedures, the radiated energy which has not been absorbed at the retina choroid interface to produce the desired bond, is directed out of the eye eliminating the possibility of adversely affecting other tissue in the eye.

In practicing the present invention, surgical procedures are involved to expose the suitable portion of the eye, and a point of entry is formed for the insertion of an ultrasonic probe to be guided to the location of the detached portion in the eye in order that the wave energy from the end of the probe can be applied directly to the detached portion. By insertion of the probe which enters the eye at an exposed area it can be properly controlled with a minimum of danger to the organ. The probe is inserted either in contact or close proximity to the area to be treated. This permits the vibrational wave energy of the end of the probe to propagate wave energy directly into the detached portion, thereby providing an efficient transfer of energy into the detached portion and its resultant joiner. The probe can be advanced such that there is direct physical contact as well as to transmit transverse vibration of the energy thereto.

In accordance with another feature of the invention, means for controlling the propagation path is provided in form of a guard in surrounding relation to the vibratory probe portion such that it minimizes the danger of the energy being transmitted to other portions which are not required to be treated.

#### BRIEF DESCRIPTION OF THE DRAWINGS

Although the characteristic features of this invention will be particularly pointed out in the claims, the invention itself, and the manner in which it may be made and used, may be better understood by referring to the following description taken in connection with the accompanying drawings forming a part hereof, wherein like reference numerals refer to like parts throughout the several views and in which:

FIG. 1, is a somewhat schematic view of an ultrasonic motor generator system for driving a tool member adapted to be inserted in the eye for performing a surgical procedure;

FIGS. 2 and 3, are enlarged schematic pictorial representations illustrating an ultrasonically vibrating tool member for joining detached retina portions to the wall of the eye;

FIG. 4, is a view taken along line 4-4 of FIG. 3 of a fragment of the eye;

FIG. 5, is a view similar to FIG. 2, illustrating another aspect of the invention;

FIGS. 6 and 7, are enlarged views partly in section, illustrating the formation of an opening through the wall of the eye; and

FIG. 8, is a view similar to FIG. 7, showing an instrument extending within the eye for performing a surgical procedure.

#### DETAILED DISCUSSION OF THE DRAWINGS

Referring now to the drawings and particularly to FIG. 1 thereof, we see the schematic representation of an eye 10 having the various portions thereof including a retina 12, in a par-

ticular area 14 with spaced apart detached portions 16 and 18 from the choroid 20. The area 14 is detectable in a conventional manner such that the surgeon is aware of its location and will conduct the operation with the intent to rejoin the detached portions, or portion, to the choroid 20 without substantially, if at all injuring the associated parts thereof including the sclera 22. The wall 25 is intended to define any portion of the eye which when pierced will connect the interior of the eye to the exterior and will generally include all, or portions, of the retina 12, choroid 20 and sclera 22, or the sclera 22 and ciliary body 24.

Once the partial separation, or detachment of the retina 12 from the choroid 20 is detected, and this generally occurs with respect to the superior temporal part of the retina which is most commonly affected, but any part or even the entire retina may become detached, then the reattachment of the retina can be accomplished in accordance with the teachings of the present invention. First an incision or opening 27 in the eye 10 to permit the insertion of a probe 30 therethrough to reach the specific area to be treated. The process of forming the opening 27, is discussed in greater detail in applicant's copending patent application hereinabove referred to, but is hereinafter described to illustrate its use with the present invention, since it is capable of being used not only for the reattachment of the retina but also for various other operative procedures and uses both with the eye and other portions of the anatomy. It is accordingly so described and intended.

Once the opening is formed the probe 30 is inserted therein such that the tip having a distal end or vibratory surface 32, is positioned within the vitreous material 34 contained in the eye 10 and the vibrational wave energy may be propagated through the vitreous material 34 to obtain a joining or a bonding of the detached portions 16 and 18 to the wall 25, such as the choroid 20 and the sclera 22. The vibrational wave energy or ultrasonic energy, as the terms are herein used is intended to include vibratory energy in the frequency range of from 1 kilohertz to 20 megahertz although the preferable range is generally from 10 kilohertz to 100 kilohertz.

Referring further to FIG. 1 it will be seen that the apparatus or probe 30 for ultrasonically performing surgical procedures on a biological organism, such as a human, may include an ultrasonic transducer or motor 35 for effecting the necessary high-frequency vibrations of the vibratory element or tool member 36 having a distal end or output surface 32. The ultrasonic motor 35, as illustrated may be in the form of a driving member adapted for being hand held as by an operator 38, and generally comprising a tubular housing or casing 40 into which an insert unit supporting the tool member 36 may be partially telescoped. The ultrasonic motor 35 is energized by an oscillation generator 42, with a power cable 44, connecting the two together. The generator is an oscillator adapted to produce electrical energy of the desired frequency.

The ultrasonic motor 35 may be one of a variety of electromechanical types, such as electrodynamic, piezoelectric or magnetostrictive. The ultrasonic motor for effecting surgical procedures through hand-directed tools of suitable configuration, which are readily replaceable or interchangeable with other work-performing tools in acoustically vibrated material treating devices, may be of the type in which each work tool member is rigidly joined, in end-to-end relationship to a connecting body or acoustic impedance transformer and to a transducer which may form an insert unit or assembly which is removably supported in a housing containing a coil in surrounding relationship to the transducer and receiving alternating current for producing an alternating electromagnetic field.

The transducer in the ultrasonic motor 35 is longitudinally dimensioned so as to have lengths which are whole multiples of half-wave lengths of the compressional waves established therein at the frequency of the biased alternating current supplied so that longitudinal loops of motion as indicated by arrow 45, occur with maximum displacement at the vibratory surface 32 of the vibratory element 36 that is rigidly connected to the insert unit. Thus, the optimum amplitude of lon-

gitudinal vibration and hyperaccelerations of vibratory element 36 is achieved, and such amplitude is determined by the relationship of the masses on both sides of the nodal region of the tool member which may be made effective to either magnify or reduce the amplitude of the vibrations received from the transducer.

The vibratory element 36 may be permanently attached to the transducer, for example, by brazing, solder or the like, or the tool may be provided with a threaded stud adapted to be screwed into a tapped hole in the end of the transducer for effecting the rigid connection of the tool.

The ultrasonic motor 35 in the casing 40 may include a magnetostrictive transducer for intermittent operation, which is composed of a stack of magnetostrictive laminations and a metallic connecting body part of which is the vibratory element 36. Incorporated in ultrasonic motor 35 is one or two coils, when two coils are used one is the driving coil, and the other is the pickup coil. The driving coil carries the DC and RF energizing currents from the ultrasonic generator 42. The DC current provides the magnetic biasing necessary for an efficient operation of the magnetostrictive laminations. The RF current has generally a sinusoidal shape, it provides the energy required to initiate and maintain the ultrasonic vibration at the resonance of the vibratory system. This current is generating an alternate magnetic field which is superimposed on the biasing one. The ratio of the two fields and their relation to saturation of the lamination is such to provide the greater electromechanical coupling and transducer efficiently with the smallest possible exciting power.

The pickup coil is located at one end of the stack of magnetostrictive laminations thus sensing the variations of strength of the magnetic field due to changing in stress in the cross section of the magnetostrictive laminations. The variation in field strength causes an inductive voltage as an electromotive force for the current through a closed loop comprising the pickup and the generator oscillator 42. The generator 42 responds to the maximum signal which is produced at resonance, so that it will drive the system at its momentary resonant frequency regardless of the particular load at that time applied by the vibratory element 36 within the eye 10.

The generator 42 is provided with control means for setting the time of duration of the emission of ultrasonic energy by adjusting the dial 47. For power adjustment dial 49 is provided which controls the amount of power delivered to the ultrasonic motor.

The vibratory stroke of the distal end 32 of the vibratory element 36 is controlled by manual setting of the power dial 49 on the generator. The time of duration of ultrasonic radiation is defined by positioning the dial 47 on the generators front panel, and the energy may be continuous or intermittent.

The vibratory stroke and the time of duration of vibration are the only parameters controlling the amount and with it the effect of ultrasonic vibration. These two parameters can be easily adjusted very precisely, so that results can be controlled and reproduced by setting of the control dials 49 and 47 on the generator 42.

The vibratory element 36 may be of monel and one-half wavelength long,  $\tau/2$ , where  $\tau = c/y$ ,  $c$  being the velocity of sound in a monel rod, and  $f$  being the operating frequency. The  $\tau/4$  long output section has to have the minimum possible outside diameter preferably not greater than 1.5 mm. in diameter, sufficient only to create a relatively small inflammatory irritation at the distal end 32. A linelike effect may be produced by maneuvering the motor 35 to any position by movement along an angular path as indicated by arrow 48, in such a way to guide the tip 32 over the desired region. A small diameter at the vibratory surface 32 is essential to be able to work through a relatively small incision 27. In the proximity of the nodal region of the wave guide a flangelike increase in diameter is provided for supporting purposes.

The vibratory probe 30 is provided with means for controlling the propagation path as by using guard means 46 that may be secured to the casing 40 of the motor 35 in any con-

ventional manner and which may be in the form of a tubular member 51 mounted in coaxial alignment with the vibratory element 36 and designed to prevent rubbing between the vibratory element and the housing when the tip is vibrating, thus, preventing generation of heat due to friction. The protective tubing 51 also serves as an insulator or as a reflector to prevent ultrasonic energy being radiated except from the vibratory surface 32, so that the propagation path is directed at the retina portion to be reattached. The protective tubing 51 may extend the length of the vibratory element 36 or beyond it if desired. The guard means 46 also serves to support the front part of the ultrasonic probe 30 when sliding axially in the supporting means 50 positioned within the opening 27 and is easily removable to permit the cleaning of the instrument.

The supporting means 50, as seen with respect to FIGS. 6-8, extends through the wall 25, such as the sclera 22 and ciliary body 24 over the most convenient region of the pars plana, and is positioned in and tightened in the incision or opening 27 by a double mattress suture 52. The support means 50 should have the ability to rotate within the opening 27. To provide a seal with the protective tubing 51 and facilitate its sliding for relative axial movement the supporting member 50 should be provided with sealing means 65, which may be in the form of an O-ring 68 contained in seat 66, and have a minimum outside diameter to be inserted into the incision 27, and possibly supported and rotated by a micromanipulator. Finally the supporting member 50 should eventually provide for an increase in volume of the vitreous cavity in order to reduce the pressure in the eye 10 during the operation.

In performing the surgical procedure we initially form the opening 27 in the wall 25 of the eye 10, which may extend through sclera 22, choroid 20, and retina 12, or the sclera 22 and ciliary body over the pars plana, the latter being preferred. The formation of the opening 27 seen with respect to FIGS. 6 through 8, and is formed by supporting means 50, which comprises a tubular body portion 53 which may be of circular cross-sectional area so that it may be rotatable after it is seated through the wall 25 of the eye 10, and includes the passageway 54 extending from the front end 56 to the rear end 58, which rear end has an upper annular flange 60 extending radially outwardly from the body portion 53 proximate the upper end thereof and adapted to overlap the outer surface of the eye 10. A lower annular flange 62 extending radially outwardly from the body portion 53 proximate the lower end thereof is adapted to extend over the inner surface of the wall portion 25. Retaining means 63 is defined by the spacing between the flanges and forms a groove 64, adapted to contain the wall portion 25 of the eye 10. The sealing means 65 provided in the passageway 54 may include a seat 66 containing the sealing member 68 which is illustrated in the form of an O-ring to provide the sealing engagement with any element or instrumentation inserted within the passageway 54. Thus, also permitting sliding engagement for relative movement with any instrument. Due to the viscosity of the vitreous material a close tolerance at one point in the passageway 54 with the protective tubing 51, or other instrument, may be sufficient to provide the sealing engagement required.

The supporting member 50 has mounted coaxially therewith cutting means in the form of cutting element 70 which includes an enlarged head section 72, adapted to be coupled to an instrument if desired, and having a base section 74 extending through the passageway 54 and terminating in a cutting surface 76 of a selected configuration. Looking means 78 is provided between the supporting means 50 and cutting means 70 in the form of a pin 80 extending from the base section 74 into a groove 82 contained within the passageway 54 to prevent angular rotation between said respective means during their insertion into the eye.

In actual practice the combined supporting means 50 and cutting means 70 are coupled together as a unit and inserted in the direction of arrow 84 as seen in FIG. 6, such that the cutting surface 76 pierces the wall 25 and is moved axially for-

ward until the position in FIG. 7 is reached and the supporting means 50 is in seated position and retained in place by the retaining means 63. The contour of the cutting surface 76 being pressed into the eye 10 is of increasing cross section and designed as a conical shape until it embraces the groove 64 of the supporting member 50. The lower flange 62 has a rounded edge 86 and tapered front such as to continue essentially the taper of the cutting surface 76 as it is forced through the wall 25. Once the position in FIG. 7 is reached the wall 25 is retained within the groove 64 and the two mattress sutures 52 may be conveniently tightened so as to prevent any of the vitreous material from flowing out and providing sealing engagement between the supporting means 50 and wall 25.

The cutting element 70 can now be withdrawn, by disengaging the locking means 78 and removing the cutting element 70 in the direction of arrow 85, leaving the passageway 54 open between the interior and exterior of the eye and in which case part of the vitreous material will tend to flow therein. It is now possible to insert through the passageway 54 different tools and instruments which normally could be attached to a solid structure like a micromanipulator, which will provide the stability and a supporting point for the front of the instrument thus, relieving the strain on the surgeon's hand. Removal of the supporting means 50 when required, is accomplished by inserting a conically pointed rod (not shown) instead of the cutting element 70, to engage the locking means 78, and to minimize damage on the eye tissue during the withdrawal of the supporting means 50, during this latter process an additional pair of mattress sutures are to be gradually tightened as the supporting means 50 is gradually removed from the wall to close up the opening 27.

As discussed in applicant's pending patent application the puncturing or cutting element 70 is a pointed two-edged knife, designed to start an incision and enlarge it to the proper length in the desired direction, the direction is defined by the positioning pin 80 contained thereon. An advantage of reinserting of a conically pointed rod into the passageway 54 before the removal of the supporting member 50 is that it forces the vitreous material from the passageway 54 back within to the eye. Insertion of the rod into the eye increases the pressure in the eye, thus reducing the clamping force around the supporting member, facilitating its removal.

Accordingly, once the supporting member 50 is in place, as seen in FIG. 8, guard means 46 is in sealing engagement with the O-ring 68 and the vibratory element 36 extends therethrough and as seen by the arrow 48 the support member may be angularly tilted such that the vibratory surface 32 as seen in FIGS. 2-5, may be properly manipulated to the desired position for propagating the energy waves.

Applicant has found that in accordance with the present invention small amounts of vibrational energy can be utilized to, in a sense, form a fusion or joiner of overlapping sections of the layers of the wall 25 which as illustrated in FIG. 1, are generally the retina 12, choroid 20, and sclera 22, this minimal amount of energy with a relatively low power unit which the generator is capable of producing which may be in the range of 2 to 100 watts, is sufficient to obtain this joiner which may be either continuous, or as seen in FIG. 4, a plurality of individual bonds or joinings 90 may be formed.

The probe 30 once inserted within the eye 10 as indicated in FIG. 1, is then brought into energy-transferring relationship with the detached portions 16 and 18 in the work area 14 as by either physical engagement of the distal end 32 therewith as seen in FIGS. 2 and 3, or in spaced apart relationship as seen in FIG. 5, with the energy waves propagated through the vitreous material 34. As seen with respect to FIGS. 2-4 a pattern of bonds may be formed which include a first or outer series of bonds 90 surrounding the respective portions 16 and 18 such that a series of tack welds provide the necessary attachment between the retina 12 and choroid 20 and thereafter the vitreous material 34 between the retina 12 and choroid 20 may be removed by either using a tool other than the vibratory element 36, or the vibratory element 36 may be brought into con-

tacting pressural relationship in the direction of arrow 91 to force the vitreous material 34 from between the portions 16 or 18 and the wall 25. In FIG. 2, one portion 16 is joined such that a second or inner series of welds 92 is obtained immediately adjacent the free edges of the detached portion 16 of the retinal wound. Once this is completed on one side thereof the opposite side is reattached as seen in FIGS. 3 and 4, such that the respective series or sets of bonds 90 and 92 are obtained. Obviously, the size, location and shape of each bond 90 and 92 will vary with respect to the size, location and extent of the damage that has taken place with respect to the detached portions 16 and 18. An end series of bonds 96, spaced apart to form a continuous seal, as seen in FIG. 4, may be necessary to prevent vitreous to again penetrate between retina 12 and choroid 20. These bonds 96 may be applied at or on the edges of the detached portions 16 and 18 of the retinal wound.

FIG. 5, illustrates the problems being brought into engagement such that the vibratory surface 32 is in spaced relation to the detached portion 16 and the bond 92 is immediately formed adjacent the edge thereof. The guard means 46 is seen extending beyond the vibratory surface 32 of the vibratory element 36 to engage and retain the retina portion 16 in place. The vibratory energy is applied in direction of double headed arrow 94 and after the bonds 92 are formed is removed in the direction of arrow 95. As seen the vitreous material 34 is removed by engaging the end of the guard means 46 against the detached portion 16 and moving the probe towards the wall portion 25 to squeeze out the vitreous material from therebetween.

The guard means 46 is held in position such that the axial outer surface of the vibratory element 36 propagates its waves only from the distal end 32 thereof. The guard means 46 has an extended lip as seen in FIG. 5, such that it extends beyond the distal end 32 and the distal end is maintained in spaced relation with the waves propagated through the vitreous material 34. If this approach is utilized the guard means 46 acts to compress the overlapping areas and force out the material therebetween. If desired the guard means 46 or even the vibratory element 36 can be coupled to conventional electronic means such that the axial force applied is controlled and the degree of pressure can be indicated exteriorly of the human which enables the operator to know when the requisite amount of pressure required is reached.

Depending upon the location and degree of separation the energy level and its amount are controlled by dials 47 and 49 of generator 42 and furthermore a frequency in the range between 1,000 cycles per second and 20,000,000 cycles per second may be used, such that the proper vibrational pattern desired is obtained. As far as the actual joining is concerned it is to be appreciated that a minimal amount of energy will effect the bond which is capable of retaining the overlapped sections of the retina 12 to the wall 25, such that the eye 10 may thereafter function in a proper manner. By maintaining the distal end 32 at a minimum diameter, generally in the range of 0.010 to 0.060 inches, and by intermittently transmitting this energy to the distal end thereof a minimal temperature rise will occur in the tissue portions such that no damage is noticeable. The energy is propagated generally in the direction normal to the interface of the two layers to be joined and although this energy is in a longitudinal mode it is appreciated that either elliptical, flexural, torsional, or even corkscrew motions may be propagated to form the bonds.

Many other changes could be effected in the particular constructions, and in the methods of use and construction, and in specific details thereof, hereinbefore set forth, without substantially departing from the invention intended to be defined herein, the specific description being merely of embodiments capable of illustrating certain principles of the invention.

I claim:

1. Apparatus for reattachment of a detached retina portion to the wall of an eye in vivo comprising

elongated means for projecting through the outer wall of the eye and having a distal end portion for reaching a selected portion of the interior wall of the eye, means including at least a portion of said elongated means and the distal end portion thereof for propagating ultrasonic vibrational energy to the detached retina portion for securing the latter to the wall of the eye, and means cooperating with at least a portion of said elongated means excluding said distal end portion for confining the transmission of said energy substantially only to said detached retina portion.

2. Apparatus as in claim 1 further comprising means for attachment to the eye for supporting said elongated means, said supporting means having a through passage through which said elongated means extends, the size of said through passage and said elongated means being as related so that the movement of said elongated means can be controlled.

3. Apparatus as in claim 1, wherein said means for propagating vibrational energy includes:

- a. transducer means coupled to said elongated member for converting alternating current electrical energy into mechanical vibration at ultrasonic frequencies and
- b. a vibratory element coupled to said transducer means to be set into vibration thereby in a given direction, the output surface of said vibratory element including the distal end portion of said elongated means for insertion within the eye in energy-transferring relation to the detached retina portion.

4. Apparatus as in claim 3, wherein said means for confining the transmission of said propagated vibrational energy includes a guard coupled to said transducer means so as to expose substantially only the output surface thereof on the distal end portion of said elongated means.

5. Apparatus as in claim 3, and including means for controlling the intensity of the energy produced by said transducer means and means for controlling the time of production

of said energy.

6. Apparatus as in claim 2, and including sealing means between said supporting means and said elongated means for propagating ultrasonic vibrational energy for retaining the vitreous material within the eye.

7. Apparatus as in claim 2, wherein said supporting means includes a support member having a groove within which the wall of the eye extends so as to obtain a fixed relation between the wall of the eye and said supporting means.

8. Apparatus for reattachment of a detached retina portion to the wall of an eye in vivo comprising elongated means for projecting through the outer wall of the eye and having a distal end portion for reaching a selected portion of the interior wall of the eye,

means including at least a portion of said elongated means and the distal end portion thereof for propagating ultrasonic vibrational energy to said distal end portion to apply the energy to the detached retina portion for securing the latter to the wall of the eye,

and means for attachment to the eye for supporting said elongated means, said supporting means having a through passage through which said elongated means extends, the size of said through passage and said elongated means being as related so that the movement of said elongated means can be controlled.

9. Apparatus as in claim 8, and including sealing means between said supporting means and said elongated means for propagating vibrational energy for retaining the vitreous material within the eye.

10. Apparatus as in claim 1 wherein said ultrasonic vibrational energy is in the range from 10 kilohertz to 100 kilohertz.

11. Apparatus as in claim 8 wherein said ultrasonic vibrational energy is in the range from 10 kilohertz to 100 kilohertz.

\* \* \* \* \*

40

45

50

55

60

65

70

75