

(12) **UK Patent**

(19) **GB**

(11) **2581125**

(13) **B**

(45) Date of B Publication

21.09.2022

(54) Title of the Invention: **A cummerbund**

(51) INT CL: **A41F 1/00** (2006.01) **A41D 13/00** (2006.01) **A45F 3/14** (2006.01) **F41H 1/00** (2006.01)

(21) Application No: **1820074.1**

(22) Date of Filing: **10.12.2018**

(43) Date of A Publication: **12.08.2020**

(72) Inventor(s):
Mark Dexter

(73) Proprietor(s):
**Warrior Assault Systems Limited
Unit 2D, 9 Opus Park, Lockhead Close,
Preston Farm Industrial Estate, Stockton on Tees,
TS18 3BP, United Kingdom**

(56) Documents Cited:
EP 3396298 A1 **WO 2013/119294 A1**
WO 2011/109453 A1 **US 20190041167 A1**
US 20050005343 A1

(74) Agent and/or Address for Service:
**Appleyard Lees IP LLP
15 Clare Road, HALIFAX, West Yorkshire, HX1 2HY,
United Kingdom**

(58) Field of Search:
As for published application 2581125 A viz:
INT CL **A41D, A41F, A45F, F41H**
Other: **WPI, EPODOC**
updated as appropriate

Additional Fields
Other: **None**

**GB
2581125
B**

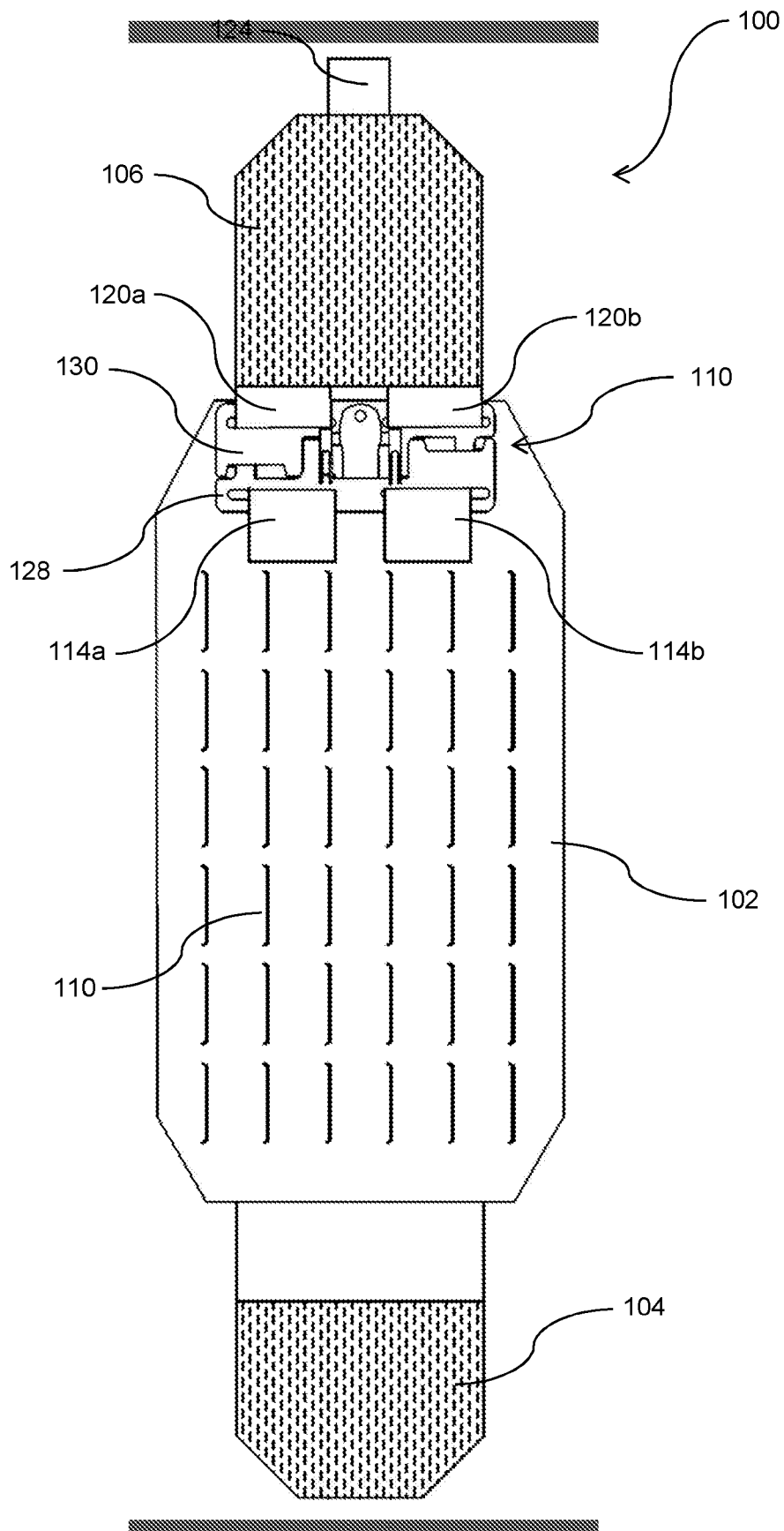

FIG. 1

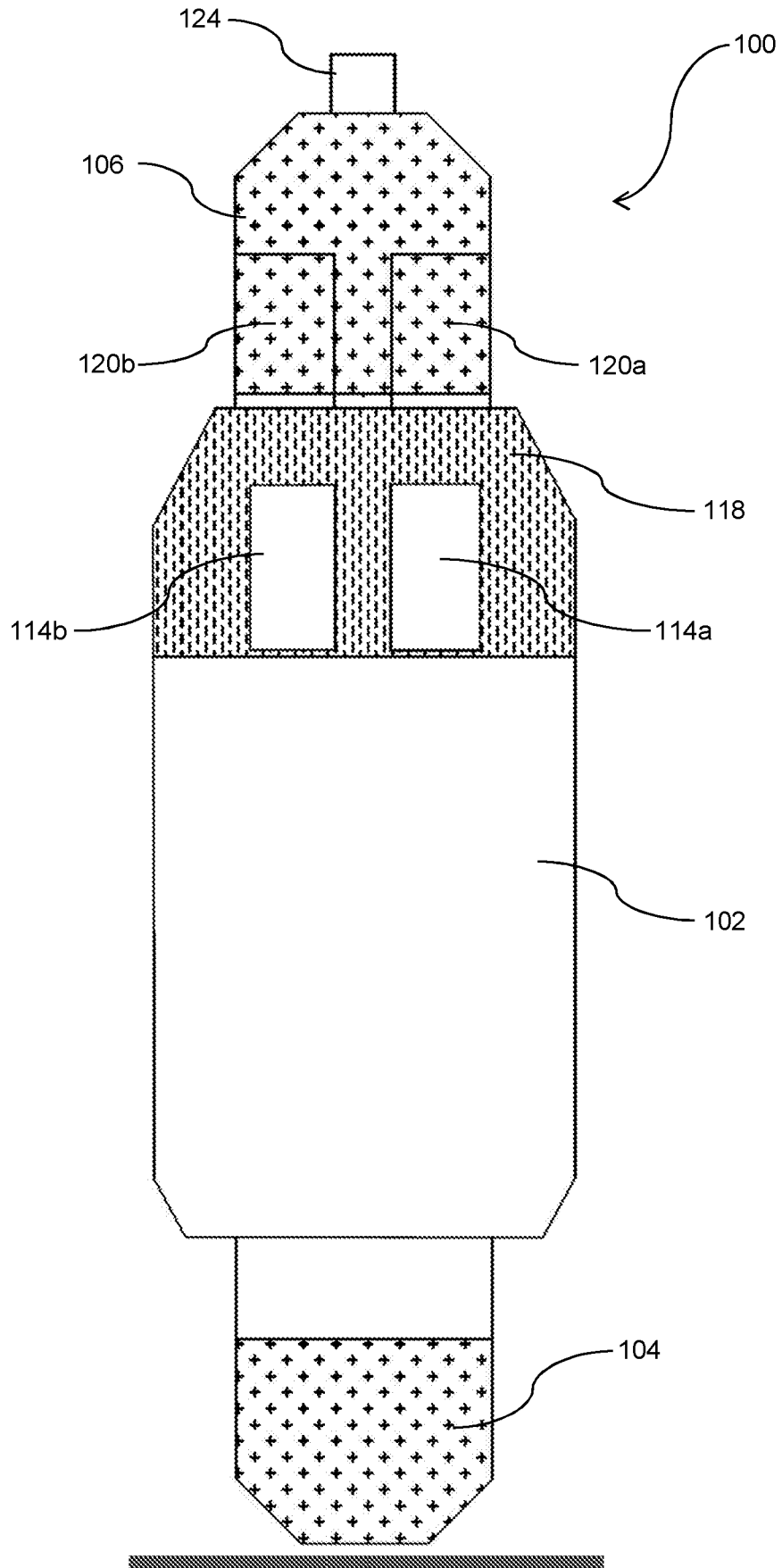

FIG. 2

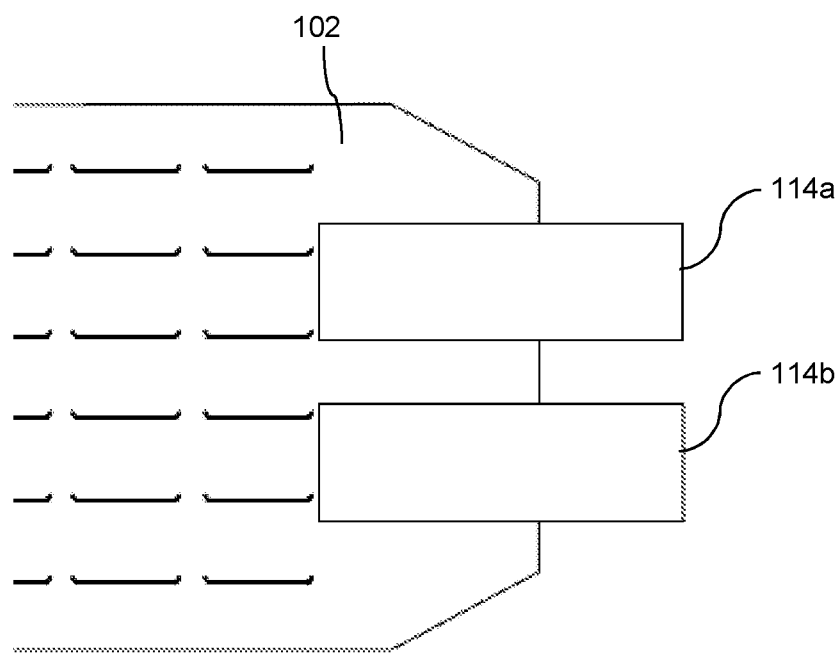

FIG. 3a

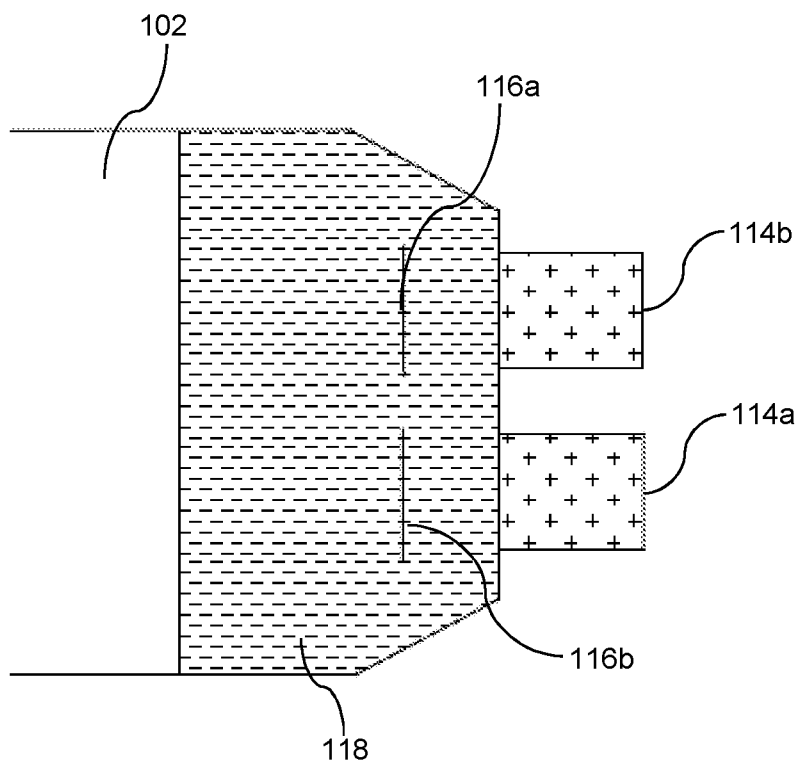
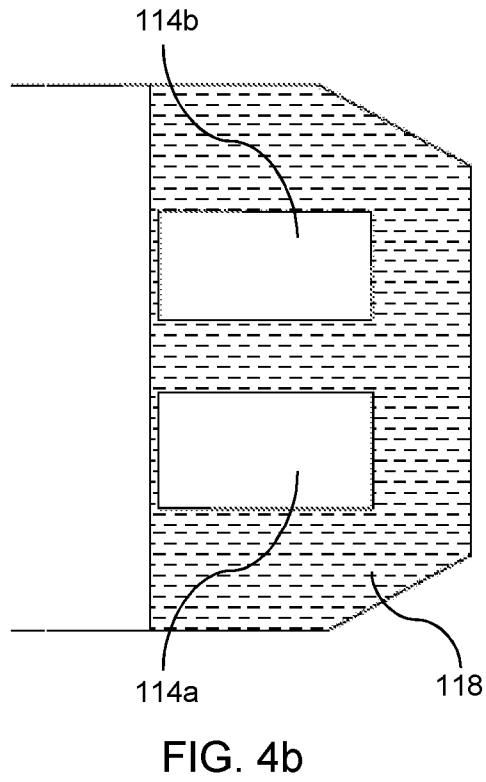
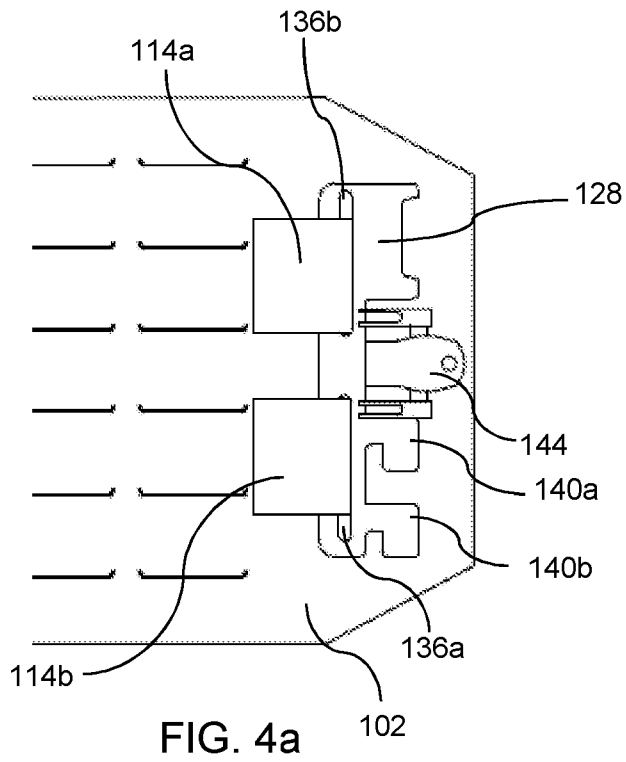

FIG. 3b



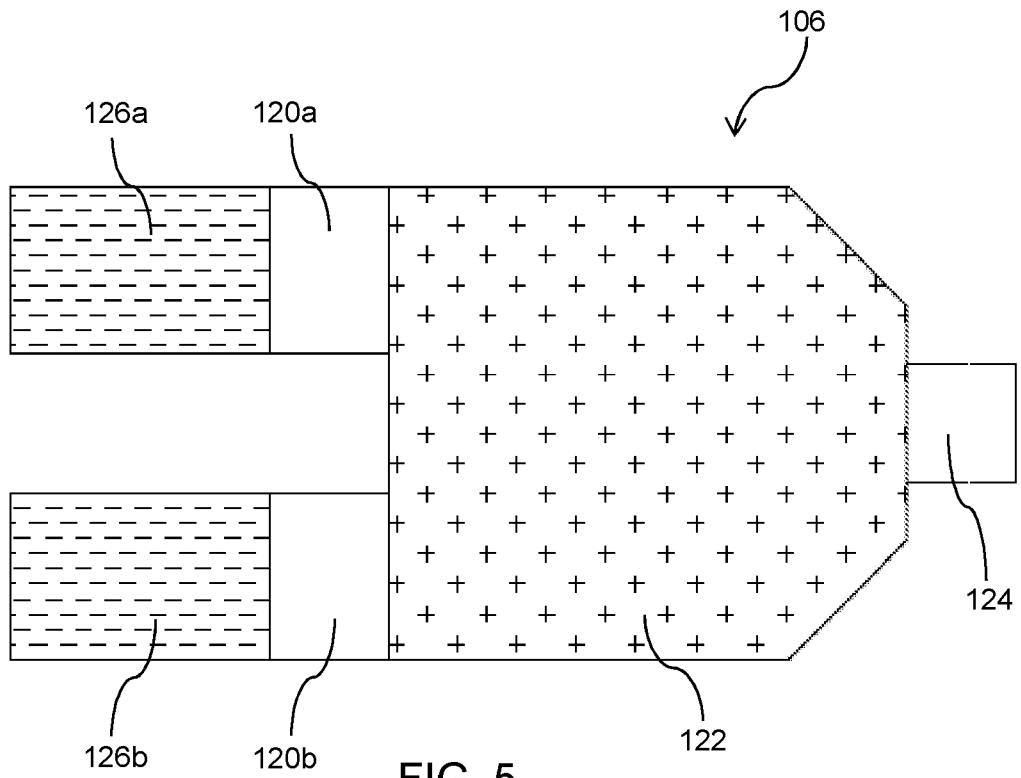

FIG. 5

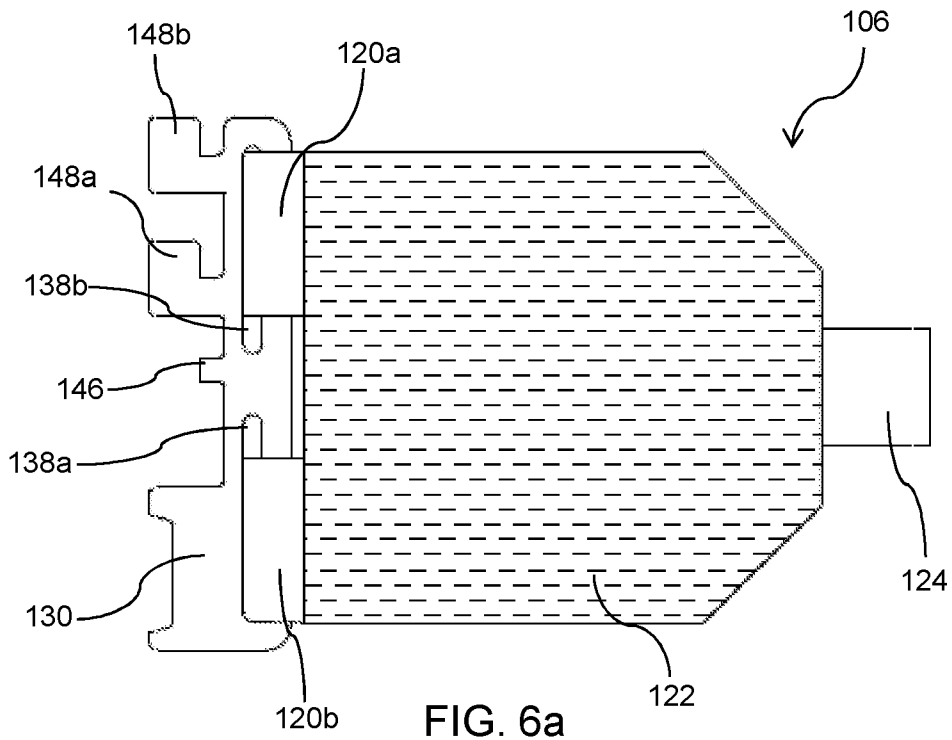
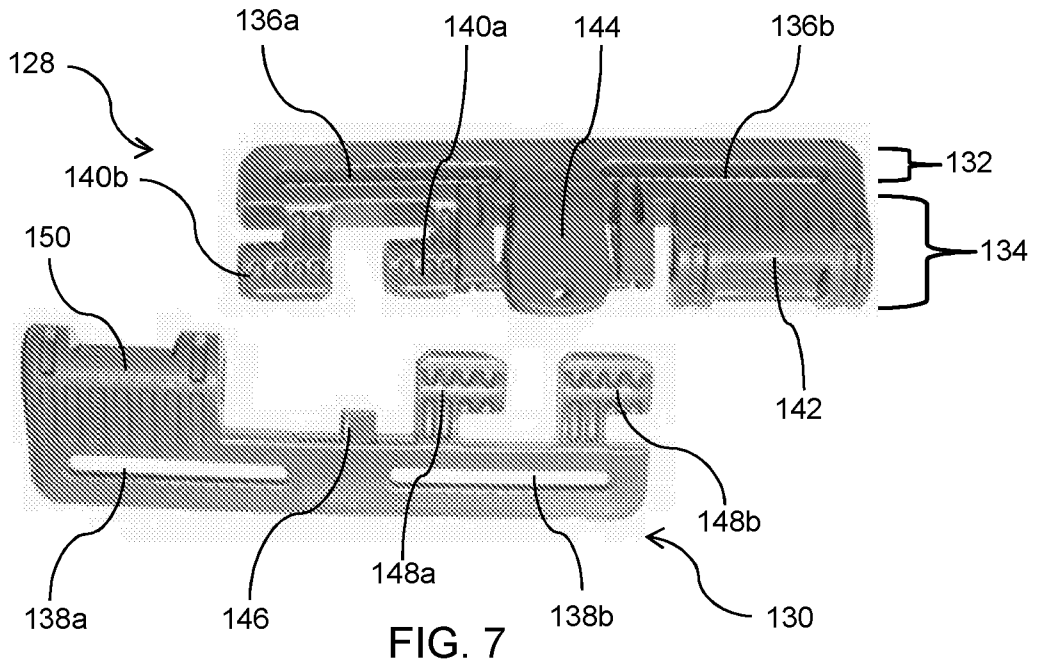
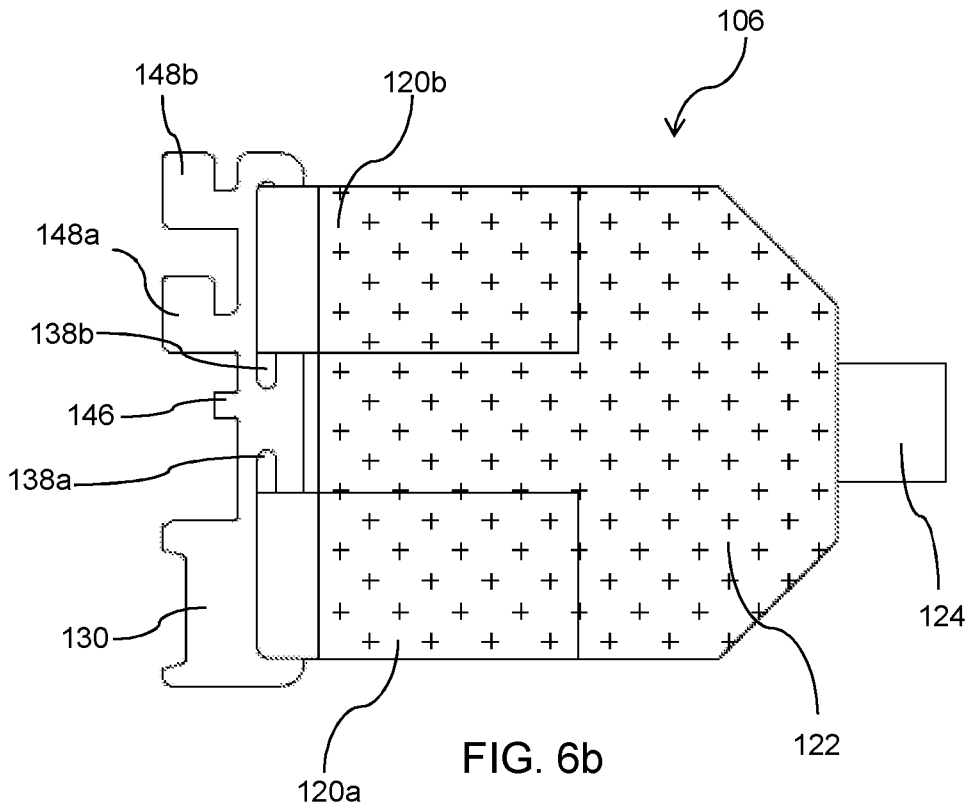

FIG. 6a



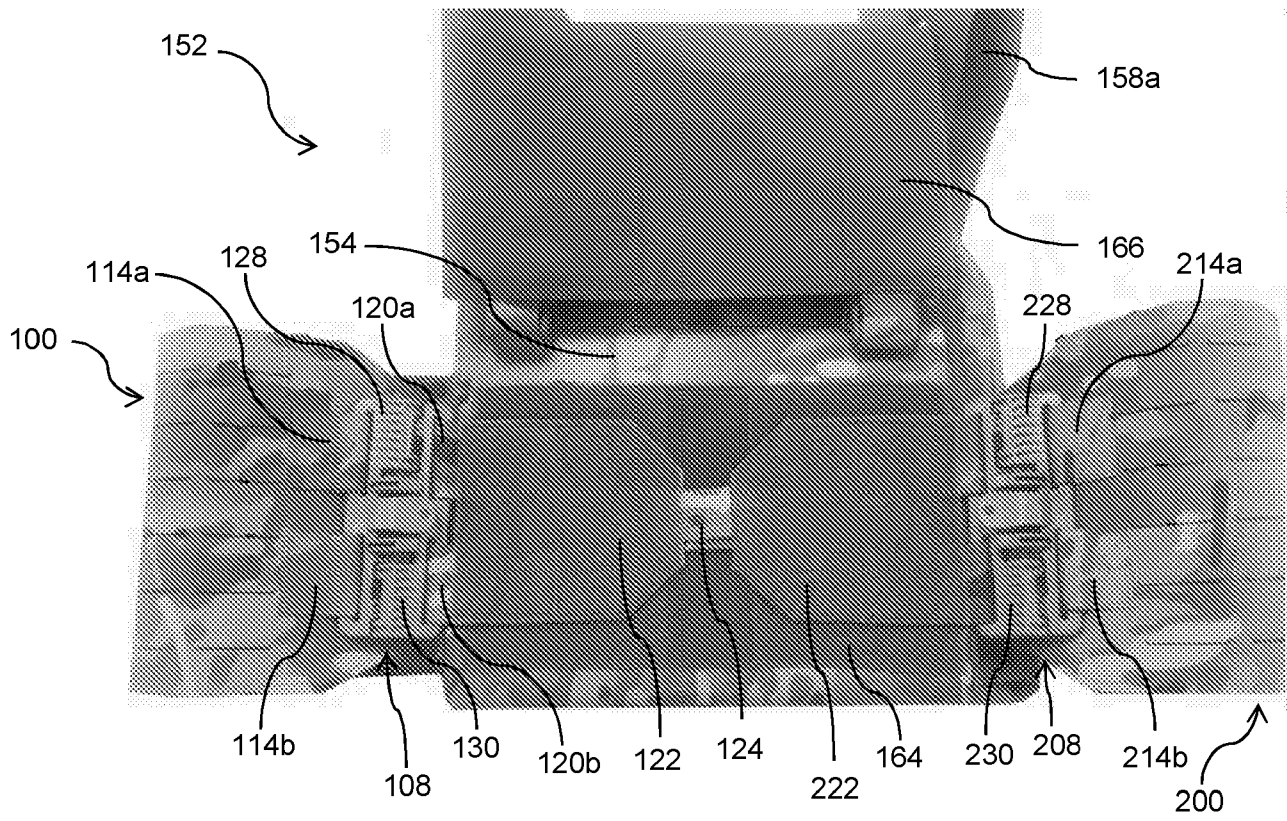

FIG. 8

A CUMMERBUND

FIELD

[01] The present invention relates to a cummerbund for a body vest, such as a plate carrier or chest rig. The invention extends to a body vest comprising the cummerbund.

BACKGROUND

[02] Body vests, such as plate carriers and chest rigs are used to provide protection and utility to the wearer. Due to their versatility, such vests have found use in many fields such as military, construction, law enforcement and in various outdoor sports and activities, such as fishing.

[03] Body vests can be formed of functional front and rear portions, which may contain armour plates or merely provides means for attaching and carrying equipment. The front portion is intended to be arranged over the front of the torso of the wearer in use, and the rear portion over the back of the torso. Such body vests can have shoulder straps that connect the chest and back portions together at the upper ends, with a gap provided between the shoulder straps to allow the wearer to pass their head through the straps when putting the vest on and taking it off. The bottom ends of the front and rear portions can be joined with a cummerbund that extends around the side of the waist of the wearer to keep the front and rear portions in contact with the torso during use.

[04] It is an object of the present invention to provide an improved cummerbund for a body vest and an improved body vest comprising the cummerbund. In particular, it is an object of the present invention to provide a cummerbund for a body vest that provides improved ease of use in combination with reliability and storage area.

SUMMARY

[05] According to the present invention there is an apparatus as set forth in the appended claims. Other features of the invention will be apparent from the dependent claims, and the description which follows.

[06] According to a first aspect of the present invention, there is provided a cummerbund for a body vest, the cummerbund comprising a first vest attachment member, a second vest attachment member, and a linking member, wherein the first and second vest attachment members are arranged toward opposite ends of the linking member, wherein the cummerbund further comprises an internal connection portion

operable to be moved from a first connected position in which the first and second vest attachment members are linked via the linking member to a second disconnected position in which the first and second vest attachment members are not linked by the linking member.

[07] The internal connection portion may comprise a first and a second connection member, wherein in the connected position the first and second connection members cooperate to form a reversible attachment between the first and second connection members and in the second disconnected position the first and second connection members are detached. Suitably, the first and/or second connection member is operable to be reversibly attached to the linking member, the first vest attachment member and/or the second vest attachment member.

[08] The internal connection portion may be a quick release mechanism. The phrase “quick release mechanism” as used herein is intended to mean a mechanism that can be more quickly released by the wearer than the mechanism that attaches the vest attachment member to the front or rear portion of the vest when that vest attachment mechanism comprises a sandwiched hook and pile attachment of the vest attachment member between a first and a second attachment member of the vest portion.

[09] The first and second connection members may each comprise one member of a cooperating pair of abutment and retaining members, wherein the abutment member is operable to engage with the retaining member such that longitudinal separation of the connection members relative to the linking member is restricted in the engaged position. Suitably, the abutment member and the retaining member are rigid. The term “rigid” as used herein in relation to the abutment and retaining members of the connection members of the internal connection portion is intended to mean that the abutment and retaining members are not operable to be moved from the engaged position to the non-engaged position by deformation of the abutment members or retaining members. Suitably, the abutment members and the retaining members of the connection members are substantially inflexible or non-deformable. Preferably, actuation of the release member comprises deformation of the release member, such as bending of the release member.

[10] The abutment member may be operable to move from a pre-engaged position wherein at least a portion of the abutment member is co-axial with the retaining member but is not engaged with the retaining member to an engaged position wherein the abutment member is engaged with the retaining member.

[11] The first and second connection members may each comprise one member of a cooperating pair of locking members, wherein the first and second locking members are operable to engage such as to form a locking engagement that prevents separation of the connection members.

[12] The connection portion may further comprises a release member and wherein actuation of the release member releases the locking engagement of the locking members such that the connection members can be separated.

[13] The abutment member and respective retaining member may be are operable move from the pre-engaged position to the engaged position by transverse movement of the abutment member and/or retaining member relative to the linking member.

[14] Locking engagement of the first and second locking members may prevent the reverse transverse movement.

[15] The abutment member may be in the form of a hooked abutment member comprising a first portion operable to extend substantially longitudinally relative to the linking member and a second portion operable to extend substantially transversely relative to the linking member when the connection member is attached to the cummerbund.

[16] The transverse portion of the abutment member may be operable to be co-axial with the retaining member in the pre-engaged position.

[17] The connection members may be operable to overlap by at least 25% when in the pre-engaged position, such as by at least 50%, or at least 75%, preferably at least 85%.

[18] Actuation of the release member may be operable to be carried out in one movement with one hand. The phrase "in one movement with one hand" as used herein is intended to mean that the wearer is able to actuate the required release members simultaneously using only one hand to allow for separation of the connection members.

[19] Release of the locking engagement to enable separation of the connection members may be operable to be achieved by actuation of up to three release members, such as up to two release members, preferably by actuation of a single release member.

[20] Each of the first and second connection members may comprise at least one abutment member and at least one retaining member, suitably at least two abutment members and at least two retaining members.

[21] The transverse portion of an abutment member of the first connection members may extend from the longitudinally extending portion in substantially the opposite direction to the transverse portion of the second connection member in the connected position, suitably, all of the transverse portions extend in substantially the opposite direction.

[22] The first and second connection members may each be integrally formed.

[23] The first and second vest attachment members may be operable to form a reversible attachment with the body vest.

[24] The first and second vest attachment members may be pliable. .

[25] The linking member may comprise an attachment member operable to form a reversible attachment with a connection member of the connection portion, preferably the attachment member is pliable, more preferable formed of a fabric.

[26] The linking member may comprise an inner face and an outer face, and wherein the connection member attachment member is attached to the inner or the outer face of the linking member, preferably to the outer face.

[27] The connection member attachment member may be pliable and wherein the linking member and the connection member each comprises an aperture configured to allow the pliable attachment member to pass through and form an attachment with the opposite face of the linking member to which the pliable member is attached, preferably with the inner face of the linking member.

[28] The linking member may comprise an attachment member on the opposite face to which the pliable member is attached, wherein the attachment member of the opposite face is operable to form a reversible attachment with the pliable attachment member.

[29] The linking member may comprise a first connection member attachment member operable to form a reversible attachment with the first connection member and further comprises a second connection member attachment member operable to form a reversible attachment with the second connection member.

[30] The first and/or the second vest attachment member may comprise an attachment member operable to form a reversible attachment with a connection member, preferably the attachment member is pliable, more preferably formed of a fabric.

[31] The first and/or second vest attachment member may comprise an inner face and an outer face, and wherein the connection member attachment member is attached to the inner or the outer face of the attachment member, preferably to the inner face.

[32] The connection member attachment member may be pliable and wherein the connection member comprises at least one aperture configured to allow the pliable attachment member to pass through and form an attachment with a portion of the vest attachment member.

[33] The connection member attachment member of the linking member, the first vest attachment member and/or the second vest attachment member may comprise at least two spaced pliable attachment members.

[34] According to a second aspect of the present invention, there is provided a body vest, suitably a plate carrier and/or a chest rig, wherein the body vest comprises a front portion and a rear portion, and wherein the body vest further comprises a cummerbund according to any preceding claim, optionally the first and/or the second vest attachment member of the cummerbund may be fixedly attached to the front and/or rear portion of the body vest, wherein when one or both of the first and/or second vest attachment members are fixedly attached to the body vest, the linking member comprises a reversible connection member attachment member for the connection member that is most longitudinally proximate to the fixedly attached vest attachment member.

[35] The front and/or back portions may comprise cummerbund attachment portions operable to form respective reversible attachments with the first and/or second vest attachment members of the cummerbund.

[36] The cummerbund attachment portions of the front and/or back portions may comprise a first attachment member and a cover operable to extend over the first attachment member, wherein the cover further comprises an attachment member, suitably on the inner face of the cover, preferably, the attachment member of the cover is operable to form reversible attachment with the first attachment member of the cummerbund attachment portion.

[37] The first attachment member of the cummerbund attachment portion may be operable to form a reversible attachment with a first face of a vest attachment member and the cover attachment member is operable to form a reversible attachment with a second opposed face of the vest attachment member.

[38] The first vest attachment member, the second vest attachment member, the first connection member attachment member, the second connection member attachment member, the attachment member of the opposite face of the linking member, the attachment member of the front portion and/or the attachment member of the rear portion may comprise hook and/or pile fasteners.

[39] The first and/or second vest attachment members may comprise an inner and an outer face and wherein the members are operable to form a reversible attachment on both the inner and outer face, suitably both the inner and outer face comprise hook and/or pile fasteners.

[40] The connection member attachment member of the vest attachment member may comprise an inner and an outer face and wherein the both the inner and outer face comprise attachment members operable to form a reversible attachment with at least one of the vest attachment members and/or the front and/or rear portion of the vest, suitably the attachment members of the inner and outer attachment members are hook and/or pile.

[41] Advantageously, the cummerbund according to the present invention provides an internal connection mechanism that does not require separation of the cummerbund from the body vest, enabling fast access to the torso of the wearer, in combination with improved reliability by enabling replacement of release mechanism without requiring replacement of the whole body vest. Only a small portion of the body vest must be replaced to restore the integrity of the body vest, allowing for replacement parts to be more easily carried in use. Furthermore, embodiments of the present invention provide a reliable internal release mechanism by including few moving parts in the release mechanism. The connection mechanism of the present invention also provides for improved ease of use combined with improved reliability.

[42] The cummerbund may be a partial cummerbund wherein two partial cummerbunds are required to form a complete loop around the waist of the wearer in which the front and rear vest portions are substantially prevented from being lifted off the torso of the wearer without detachment of one or both of the partial cummerbunds.

[43] As used herein, unless otherwise expressly specified, all numbers such as those expressing values, ranges, amounts or percentages may be read as if prefaced by the word "about", even if the term does not expressly appear. Also, any numerical range recited herein is intended to include all sub-ranges subsumed therein. Singular encompasses plural and vice versa. Additionally, although the present invention has been described in terms of "comprising", the cummerbund and body vests detailed herein may also be described as "consisting essentially of" or "consisting of".

BRIEF DESCRIPTION OF DRAWINGS

[44] For a better understanding of the invention, and to show how embodiments of the same may be carried into effect, reference will now be made, by way of example only, to the accompanying diagrammatic drawings in which:

[45] Figure 1 shows a plan view of a cummerbund for a body vest according to the first aspect of the invention;

[46] Figure 2 shows a plan view of the inner face of the cummerbund of Figure 1;

[47] Figure 3a shows an enlarged plan view of a short side peripheral edge of the linking member of Figure 1 in which a connection member can be attached;

[48] Figure 3b shows an enlarged plan view of the inner face of a short side peripheral edge of the linking member of Figure 1, in which a connection member can be attached;

[49] Figure 4a shows an enlarged plan view of the linking member of Figure 1, with the connection member of Figure 1 attached;

[50] Figure 4b shows an enlarged plan view of the inner face of the linking member of Figure 1, with the connection member of Figure 1 attached;

[51] Figure 5 shows a plan view of the inner face of the second vest attachment member of Figure 1, with no connection member attached;

[52] Figure 6a shows a plan view of the second vest attachment member of Figure 1, with the connection member of Figure 1 attached;

[53] Figure 6b shows a plan view of the inner face of the second vest attachment member of Figure 1, with the connection member of Figure 1 attached;

[54] Figure 7 shows a perspective view of the unattached first and second internal connection members which make up the internal connection portion of Figure 1; and

[55] Figure 8 shows a perspective view a body vest with the cummerbund of Figure 1 attached.

[56] In the drawings, corresponding reference characters indicate corresponding components.

DESCRIPTION OF EMBODIMENTS

[57] As shown in Figure 1, cummerbund 100 is formed of linking member 102, first vest attachment member 104, second vest attachment member 106, and internal connection portion 108.

[58] Linking member 102 is in the form of a substantially rectangular flexible multilayer fabric piece having an inner face that faces into the wearer during normal use and an opposed outer face that faces away from the wearer in use. Linking member 102 has two opposed short side peripheral edges and longer upper and lower peripheral edges that extend between the upper and lower ends of the side edges. A longitudinal axis can be considered to extend between the first side edge to the opposite second side edge and a transverse axis extend between the upper and lower edges. The outer face of linking member 102 comprises a plurality of equipment attachment members 110 in the form of a plurality of fabric webbing loops that extend across substantially all of the outer face of the linking member.

[59] First vest attachment member 104 is formed primarily of substantially rectangular fabric vest attachment area 112 which has hook attachments extending over substantially all of the inner face of the attachment area and pile attachments extending over substantially all of the opposed outer face of the attachment area. First vest attachment member 104 is fixedly attached to the first side edge of linking member 102 along the length of a side peripheral edge of the attachment member 104. .

[60] Two pliable fabric ribbon attachment members 114a and 114b are fixedly attached to the outer face of linking member 102 at one end of each ribbon. Ribbons 114a and 114b are attached to linking member 102 toward the second side edge of linking member 102. Ribbons 114a and 114b are attached to linking member 102 such that they are spaced and are able to extend along the longitudinal axis of the linking member 102. When fully extended, ribbons 114a and 114b are operable to pass beyond the second side edge of linking member. Ribbons 114a and 114b each have hook attachments arranged on the inner face of the ribbon toward the end of the ribbon that is not fixedly attached to linking member 102.

[61] Linking member 102 additionally has two apertures 116a and 116b in the form of elongate slits extending through linking member 102 from the outer face to the inner face. Slits 116a and 116b are each orientated to extend along the transverse axis of linking member 102, with the slits arranged co-axially along the transverse axis. Slits 116a and 116b are arranged further toward the second edge of linking member 102 than the point at which ribbons 114a and 114b are fixedly attached to linking member 102. Each slit 116a and 116b is arranged relative to a respective ribbon 114a or 114b such that when the respective ribbon 114a or 114b is extended flat over linking member 102 such that the ribbon 114a and 114b extends beyond the second edge of linking member 102 the ribbon 114a and 114b also extends over a respective slit 116a and 116b.

[62] The size of slits 116a and 116b is such that ribbons 114a and 114b are able to pass through linking member 102 with a tight fit. Linking member 102 contains an area of pile attachment material 118 arranged on the inner face of linking member 102 toward the second end. Attachment material 118 extends longitudinally from the second edge of linking member 102 to a point toward the first edge that is closer to the first edge than slits 116a and 116b. Attachment material 118 extends transversely from the upper to the lower edge. Ribbons 114a and 114b can be passed through slits 116a and 116b and attached to the attachment material 118 on the inner face to form a reversibly closed loop.

[63] Second vest attachment member 106 is structurally the same as first vest attachment member 104 with regard to the primary attachment area. Second vest attachment member 106 is not fixedly attached to linking member 102 along one edge. Instead second vest attachment member 106 forms a reversible connection with linking member 102 toward the second side edge of linking member 102. In addition to the abovementioned structure of first vest attachment member 104, second vest attachment member 106 additionally has two rectangular pliable fabric ribbons 120a and 120b extending longitudinally from one edge of vest attachment area 122 and a tab 124 fixedly attached to the opposite side edge of vest attachment area 122. Ribbons 120a and 120b are similar to ribbons in that they are fixedly attached at one end, in this instance attached to second vest attachment member 106 and have toward the opposite end attachments 126a and 126b in the form of pile suitable for a hook and pile attachment. Ribbons 120a and 120b additionally have hook attachments along the opposite face.

[64] Internal connection portion 108 comprises a first rigid plastic internal connection member 128 and a second rigid plastic internal connection member 130 which are operable to engage and lock together to form internal connection portion 108. First internal connection member 128 is reversibly attached to linking member 102 and second internal connection member 130 is reversibly attached to the second vest attachment member 106 as shown in Figures 3-9.

[65] Each connection member 128 and 130 has integrally moulded first and second opposed attachment areas 132 and 134. The first attachment area 132 of each member is in the form of a pair of apertures 136a/136b and 138a/138b each aperture operable to receive an attachment ribbon. The first attachment area 132 of the first connection member 128 receives ribbons 114a and 114b and the first attachment area 132 of the second connection member 130 receives ribbons 126a and 126b. For first connection member 128, ribbons 114a and 114b are passed through apertures 136a and 136b and then through slits 116a and 116b. To form a reversible loop enclosing first connection member 128, the hooks of ribbons 114a and 114b are contacted with the pile on the inner face of linking member 102. In a similar manner, for second connection member 130, ribbons 126a and 126b are passed through apertures 138a and 138b and the pile of ribbons 120a and 120b is attached to the hook attachments on the inner face of the attachment area 122 of the second attachment member 106 to form a reversible loop that encloses the second connection member 130. The hooks on the opposite face of ribbons 120a and 120b replace the hooks that are used up by attaching ribbons 120a and 120b to the attachment area 122.

[66] The second attachment area 134 of first connection member 128 is formed of two hooked abutment 140a and 140b, a-partially open sided and open ended cylindrical retaining member 142 and locking/release member 144. The hooked abutments 140a and 140b, cylinder 142 and locking/release member 144 are all integrally moulded with connection member 128 and they all extend from connection member 128 in the same direction and are all substantially co-planar. Hooked abutments 140a and 140b are spaced and are arranged proximate to a first end of connection member 128. The longitudinally extending end portion of L-shaped hooked abutment 140a and 140b (relative to the connecting member, transverse extending relative to the linking member in normal use) extends toward the end of connection member 128 to which hooked abutments 140a and 140b are proximate. Cylinder 142 is arranged at the opposite end of connection member 128. Locking/release member 144 is arranged between hooked abutments 140a and 140b and cylinder 142. Cylinder 142 is formed of opposed

annular framed open ends and a longitudinal axis extending between the open ends. A portion of the side of the cylinder 142 extending between the annular frames is open.

[67] The second attachment area 134 of second connection member 130 is the same as the second attachment area 134 of the first connection member 128 except that locking/release member 144 is only an locking member abutment 146 without a release member, and is substantially co-planar, with and extends in the same direction as, the hooked projections 148a and 148b and cylinder 150.

[68] To connect first and second connection members 128 and 130, connection members 128 and 130 are firstly brought together through movement along the longitudinal axis of the linking portion 102 such that connection members 128 and 130 are slightly off-set by inserting the end-most hooked abutments 140b and 148b of each connection member 128 and 130 into the open side of the cylinder 142 and 150 of the respective other connection member 128 and 130 such that the longitudinally extending portions of the hooked abutments 140a, 140b, 148a and 148b are co-axial with the longitudinal axis of the respective cylinder 142 and 150. In a second movement, one or both of the connection members are moved along the transverse axis of the linking member 102 until locking member 146 forms a locking engagement with the locking member 144 of first connection member 128 such that the reverse transverse movement is prevented. When a locking engagement is made, the longitudinally extending portions of the hooked abutments 140a, 140b, 148a and 148b of each of the first and second connection members 128 and 130 protrude into the framed open ends of the cylinder 142 and 150 and abut against the annular frames such that longitudinal separation of the connection members is prevented.

[69] To release the locking engagement, the release members of the locking/release member 144 is lifted until locking member 146 is released and the reverse transverse movement is available. The reverse transverse movement is then carried out until hooked projections 140a, 140b, 148a and 148b no longer abut the frame of the open ends, thereby permitting longitudinal separation of first and second connection members 128 and 130.

[70] First and second connection members 128 and 130 are configured such that a locking engagement between locking member 146 and locking/release member 144 cannot be achieved until hooked projections 140a, 140b, 148a and 148b protrude into the respective open end frame.

[71] When connection members 128 and 130 are engaged and connected, first and second vest attachment members 104 and 106 are connected via linking member 102. When connection members 128 and 130 are disconnected, first and second vest attachment members 104 and 106 are disconnected, i.e. there is no physical link between first and second vest attachment members 104 and 106.

[72] As shown in Figure 8, body vest 152, suitably a plate carrier/ chest rig, has front portion 154 and rear portion 156 (not shown), in which front portions 154 and rear 156 cover the front and back of the torso of a wearer, respectively. Front and rear portions 154 and 156 are connected at the upper ends by two spaced fixedly attached shoulder linking members 158a and 158b (not shown). Front and rear portions 154 and 156 have a plurality of equipment attachment members (not shown) extending across substantially all of the outer face of the portion. Front and rear portions 154 and 156 each have attachment members 160 and 162 arranged on the lower half of the outer face of the front and rear portions 154 and 156. Attachment members 160 and 162 are each formed of a first attachment area 164 having loop attachments and a cover flap 166 that is fixedly attached along the upper edge of the first attachment area 164, has pile arranged on the inner face and is operable to reversibly cover and form an attachment with the first attachment area 164. Arranged over substantially all of the outer face of cover flap 166 are a plurality of equipment attachment members (not shown).

[73] Body vest 152 further has two cummerbunds 100 and 200 according to the present invention and as described above. First vest attachment member 104 and 204 of each cummerbund 100 and 200 is sandwiched between the first and second attachment areas 162 of the rear portion 156 to reversibly attach the cummerbunds 100 and 200 to the rear portion 156 of body vest 152. The second vest attachment member 122 and 222 of each cummerbund 100 and 200 is sandwiched between the first and second attachment areas of the front portion 164 and 166 to reversibly attach the cummerbunds 100 and 200 to the front portion 154 of body vest 152. In this configuration, when the connection portion is in the engaged and connected position cummerbunds 100 and 200 extend around opposite sides of the waist of the wearer and hold the vest 152 in position on the wearer. When the connection portion is in the disconnected position, front portion 154 and/or rear portion 156 of the vest 152 may be lifted away from the wearer to facilitate removal of the vest 152, or at least access to the wearer under the respective portion.

[74] If one of connection members 128 or 130 are damaged, either may be quickly replaced with a new connection member, which spares can be easily carried by the wearer.

[75] Attention is directed to all papers and documents which are filed concurrently with or previous to this specification in connection with this application and which are open to public inspection with this specification, and the contents of all such papers and documents are incorporated herein by reference.

[76] All of the features disclosed in this specification (including any accompanying claims, abstract and drawings), and/or all of the steps of any method or process so disclosed, may be combined in any combination, except combinations where at least some of such features and/or steps are mutually exclusive.

[77] Each feature disclosed in this specification (including any accompanying claims, abstract and drawings) may be replaced by alternative features serving the same, equivalent or similar purpose, unless expressly stated otherwise. Thus, unless expressly stated otherwise, each feature disclosed is one example only of a generic series of equivalent or similar features.

[78] The invention is not restricted to the details of the foregoing embodiment(s). The invention extends to any novel one, or any novel combination, of the features disclosed in this specification (including any accompanying claims, abstract and drawings), or to any novel one, or any novel combination, of the steps of any method or process so disclosed.

CLAIMS

1. A cummerbund for a body vest, the cummerbund comprising a first vest attachment member, a second vest attachment member, and a linking member, wherein the first and second vest attachment members are arranged toward opposite ends of the linking member, wherein the cummerbund further comprises an internal connection portion operable to be moved from a first connected position in which the first and second vest attachment members are linked via the linking member to a second disconnected position in which the first and second vest attachment members are not linked by the linking member.
2. A cummerbund according to claim 1, wherein the internal connection portion comprises a first and a second connection member, wherein in the connected position the first and second connection members cooperate to form a reversible attachment between the first and second connection members and in the second disconnected position the first and second connection members are detached.
3. A cummerbund according to claim 2, wherein the first and/or second connection member is operable to be reversibly attached to the linking member, the first vest attachment member and/or the second vest attachment member.
4. A cummerbund according to any preceding claim, wherein the internal connection portion is a quick release mechanism.
5. A cummerbund according to any preceding claim, wherein the first and second connection members each comprise one member of a cooperating pair of abutment and retaining members, wherein the abutment member is operable to engage with the retaining member such that longitudinal separation of the connection members relative to the linking member is restricted in the engaged position.
6. A cummerbund according to claim 5, wherein the abutment member and the retaining member are rigid.
7. A cummerbund according to claim 5 or 6, wherein the abutment member is operable to move from a pre-engaged position wherein at least a portion of the abutment member is co-axial with the retaining member but is not engaged with the retaining member to an engaged position wherein the abutment member is engaged with the retaining member.

8. A cummerbund according to any proceeding claim, wherein the first and second connection members each comprise one member of a cooperating pair of locking members, wherein the first and second locking members are operable to engage such as to form a locking engagement that prevents separation of the connection members.
9. A cummerbund according to claim 8, wherein the connection portion further comprises a release member and wherein actuation of the release member releases the locking engagement of the locking members such that the connection members can be separated.
10. A cummerbund according to any of claims 7 to 9, wherein the abutment member and respective retaining member are operable move from the pre-engaged position to the engaged position by transverse movement of the abutment member and/or retaining member relative to the linking member.
11. A cummerbund according to claim 10, wherein locking engagement of the first and second locking members prevents the reverse transverse movement.
12. A cummerbund according to any of claims 5 to 11, wherein the abutment is in the form of a hooked abutment member comprising a first portion operable to extend substantially longitudinally relative to the linking member and a second portion operable to extend substantially transversely relative to the linking member when the connection member is attached to the cummerbund.
13. A cummerbund according to any of claims 7 to 12, wherein the connection members are operable to overlap by at least 25% when in the pre-engaged position.
14. A cummerbund according to any of claims 9 to 13, wherein actuation of the release member is operable to be carried out in one movement with one hand.
15. A cummerbund according to any of claims 5 to 14, wherein each of the first and second connection members comprise at least one abutment member and at least one retaining member.
16. A cummerbund according to any preceding claim, wherein the linking member comprises an attachment member operable to form a reversible attachment with a connection member of the connection portion.

17. A cummerbund according to claim 16, wherein the linking member comprises an inner face and an outer face, and wherein the connection member attachment member is fixedly attached to the outer face of the linking member.

18. A cummerbund according to claim 16 or 17, wherein the connection member attachment member is pliable and wherein the linking member and the connection member each comprises an aperture configured to allow the pliable attachment member to pass through and form an attachment with the opposite face of the linking member to which the pliable member is attached

19. A cummerbund according to any of claims 2 to 18, wherein the first and/or the second vest attachment member comprises an attachment member operable to form a reversible attachment with a connection member, preferably the attachment member is pliable.

20. A body vest, suitably a plate carrier and/or a chest rig, wherein the body vest comprises a front portion and a rear portion, and wherein the body vest further comprises a cummerbund according to any preceding claim, optionally the first and/or the second vest attachment member of the cummerbund may be fixedly attached to the front and/or rear portion of the body vest, wherein when one or both of the first and/or second vest attachment members are fixedly attached to the body vest, the linking member comprises a reversible connection member attachment member for the connection member that is most longitudinally proximate to the fixedly attached vest attachment member.

21. A body vest according to claim 20, wherein the front and/or back portions comprise cummerbund attachment portions operable to form respective reversible attachments with the first and/or second vest attachment members of the cummerbund.

22. A body vest according to claim 20 or 21, wherein the cummerbund attachment portions of the front and/or back portions comprise a first attachment member and a cover operable to extend over the first attachment member, wherein the cover further comprises an attachment member, suitably on the inner face of the cover.

23.. A cummerbund or body vest according to any proceeding claim, wherein the first vest attachment member, the second vest attachment member, the first connection member attachment member, the second connection member attachment member, the attachment member of the opposite face of the linking member, the attachment

member of the front portion and/or the attachment member of the rear portion comprises hook and/or pile fasteners.

24. A cummerbund or body vest according to any proceeding claim, wherein the connection member attachment member of the vest attachment member comprises an inner and an outer face and wherein the both the inner and outer face comprise attachment members operable to form a reversible attachment with at least one of the vest attachment members and/or the front and/or rear portion of the vest..