

(19) World Intellectual Property Organization
International Bureau



(43) International Publication Date
29 December 2011 (29.12.2011)

(10) International Publication Number
WO 2011/161464 A1

(51) International Patent Classification:
A61L 9/12 (2006.01) A61L 9/14 (2006.01)
A01M 1/20 (2006.01)

(21) International Application Number:
PCT/GB2011/051190

(22) International Filing Date:
24 June 2011 (24.06.2011)

(25) Filing Language: English

(26) Publication Language: English

(30) Priority Data:
1010592.2 24 June 2010 (24.06.2010) GB

(71) Applicant (for all designated States except US):
RECKITT & COLMAN (OVERSEAS) LIMITED
[GB/GB]; 103-105 Bath Road, Slough, Berkshire SL1
3UH (GB).

(72) Inventors; and

(75) Inventors/Applicants (for US only): **KULKE, Torsten**
[DE/DE]; Symrise AG, Mühlenfeldstraße 1, 37603 Holz-
minden (DE). **STEPHENSON, Helen** [GB/GB]; Reckitt
Benckiser, Dansom Lane, Hull, Yorkshire HU8 7DS
(GB). **WALSH, Steve** [GB/GB]; Reckitt Benckiser, Dan-

som Lane, Hull, Yorkshire HU8 7DS (GB). **WOOD-
MAN, Cheryl** [GB/GB]; Reckitt Benckiser, Dansom
Lane, Hull, Yorkshire HU8 7DS (GB).

(74) Agents: **CARLIN, Robert G.** et al.; Reckitt Benckiser
Corporate Services Limited, Legal Department - Patents
Group, Dansom Lane, Hull, Yorkshire HU15 1PT (GB).

(81) Designated States (unless otherwise indicated, for every
kind of national protection available): AE, AG, AL, AM,
AO, AT, AU, AZ, BA, BB, BG, BH, BR, BW, BY, BZ,
CA, CH, CL, CN, CO, CR, CU, CZ, DE, DK, DM, DO,
DZ, EC, EE, EG, ES, FI, GB, GD, GE, GH, GM, GT,
HN, HR, HU, ID, IL, IN, IS, JP, KE, KG, KM, KN, KP,
KR, KZ, LA, LC, LK, LR, LS, LT, LU, LY, MA, MD,
ME, MG, MK, MN, MW, MX, MY, MZ, NA, NG, NI,
NO, NZ, OM, PE, PG, PH, PL, PT, RO, RS, RU, SC, SD,
SE, SG, SK, SL, SM, ST, SV, SY, TH, TJ, TM, TN, TR,
TT, TZ, UA, UG, US, UZ, VC, VN, ZA, ZM, ZW.

(84) Designated States (unless otherwise indicated, for every
kind of regional protection available): ARIPO (BW, GH,
GM, KE, LR, LS, MW, MZ, NA, SD, SL, SZ, TZ, UG,
ZM, ZW), Eurasian (AM, AZ, BY, KG, KZ, MD, RU, TJ,
TM), European (AL, AT, BE, BG, CH, CY, CZ, DE, DK,
EE, ES, FI, FR, GB, GR, HR, HU, IE, IS, IT, LT, LU,
LV, MC, MK, MT, NL, NO, PL, PT, RO, RS, SE, SI, SK,

[Continued on next page]

(54) Title: VOLATILE LIQUID EMANATION DEVICE WITH CAPILLARY

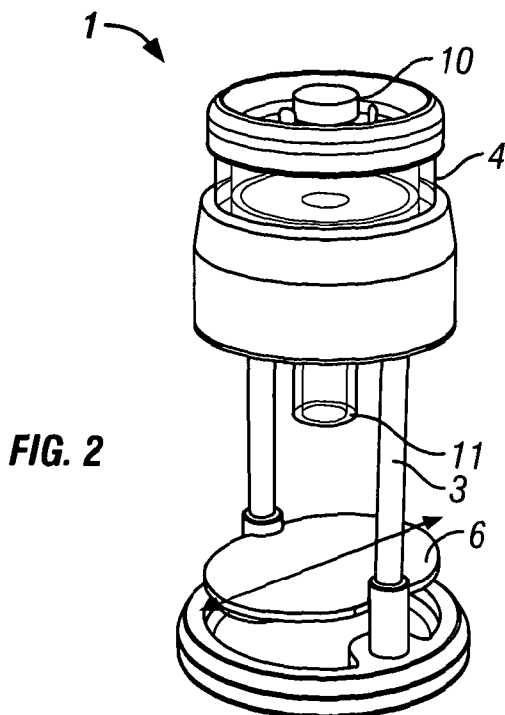

(57) Abstract: An emanation device for emanating a volatile liquid is described wherein the volatile liquid containing one or more active materials wherein the active material comprises at least one of: a fragrance; an insecticide; a fungicide; a pesticide; a sanitising material; and/or a pharmaceutical; and wherein the emanation device comprises; a housing; a passive delivery mechanism; a powered emanation means; wherein the housing is arranged to support the passive delivery mechanism in spatial arrangement over the emanation means; and wherein the delivery mechanism comprises a volatile liquid reservoir; one or more capillary tubes in fluid communication with the reservoir at one end thereof wherein said one or more capillary tubes are in non-valved fluid communication with the reservoir; and a nozzle located at the end of the or each capillary tube(s) remote from the reservoir wherein the or each nozzle is in non-valved fluid communication with the or each capillary tube(s).

WO 2011/161464 A1

SM, TR), OAPI (BF, BJ, CF, CG, CI, CM, GA, GN, GQ, GW, ML, MR, NE, SN, TD, TG). **Published:**

— with international search report (Art. 21(3))

VOLATILE LIQUID EMANATION DEVICE WITH CAPILLARY

Field of the Invention

The present invention relates to a volatile liquid delivery mechanism for an emanation device wherein said volatile liquids comprise active components such as fragrances, insecticides, fungicides, pesticides, sanitizing materials and pharmaceuticals are provided, and particularly the present invention relates to a passive, non-powered volatile liquid delivery mechanism for a powered emanation device.

Background

Conventional passive emanation devices for volatile liquids typically work by exposing a one side of a permeable membrane to a reservoir of the volatile liquid. In such membrane-containing emanation devices, the membrane is in constant contact on one side thereof with the liquid and exposed to the external environment on its other side. The contact between the volatile liquid and membrane causes the membrane to uptake the liquid by capillary action and/or diffusion, thus permitting the emanation of the liquid by evaporation from its surface exposed to the environment. Whilst such devices are simple to construct they contain several drawbacks, some of which are identified below.

One drawback, particularly with the emanation of air fresheners is that of a phenomenon called "habituation". Habituation is when users of a continuously emanating air freshener get so used to the fragrance of the air freshener that they become unable to notice it after a period of time. This is problematic in particular with non-automated air freshening devices where the user is given no visual clues as to whether the device is emanating a fragrance or not.

A further drawback associated with devices having a membrane in constant contact with a volatile material, such as a volatile liquid air freshener, is the phenomena of vacuum build-up. The vacuum build-up phenomena can occur inside the housing due to the wetted membrane being unable to allow sufficient flow of air therethrough in order to equalise the drop in pressure inside the housing caused by the emanation of the volatile material. This build-up phenomena can cause unacceptable performance problems with such a device from a consumer perspective.

In the field of air freshening it is generally preferred to use a volatile liquid fragrance/air freshener comprising several components. These components often possess different volatilities which can lead to emission problems. In devices having a membrane in constant contact with the volatile liquid, an accumulation of volatile liquid components with the lowest comparative volatilities can occur leading to an undesirable non-uniform emanation profile for the liquid.

In either or both cases of build-up phenomena and accumulation of low volatility components, the evaporation rate, and thus the emanation rate, of the volatile liquid adopts the profile shown in Graph 1 below.

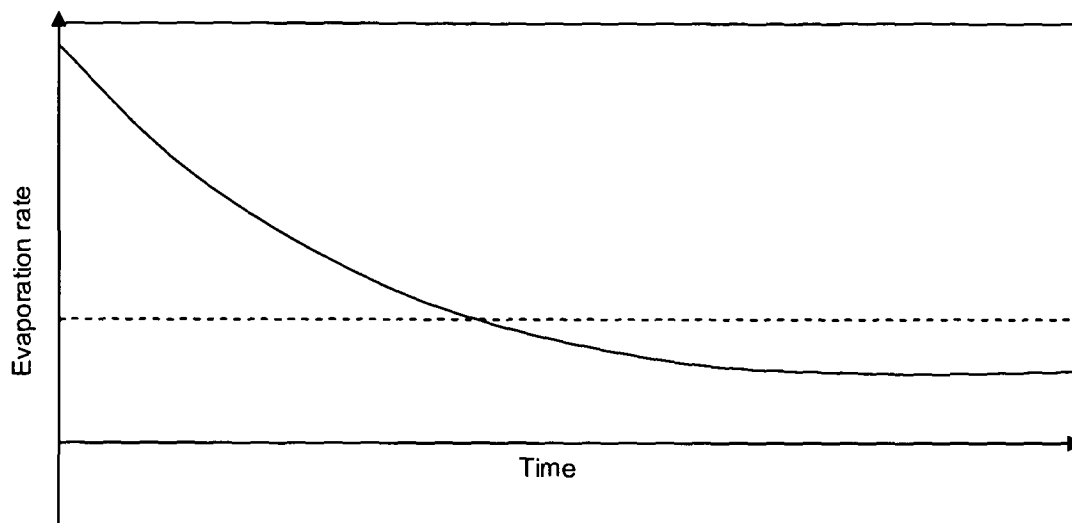

Graph 1

Eventually the emanation rate may reach equilibrium (dashed line) where the rate of evaporation of each individual component of the volatile liquid away from the membrane surface is equivalent to the rate of deposition due to diffusion and the device cannot maintain any further vacuum.

A further drawback with known passive volatile liquid emanators is that prolonged exposure of the volatile liquid to a wicking material, such as a membrane or the like, can cause fractionation over time due to various factors such as the wicking material having a limited porosity affecting liquid transfer rates/evaporation rates which, in turn, can change the character and/or intensity of the volatile liquid being emanated. Changes in character of emanated volatile liquids is particularly noticeable for fragrances wherein common wicking materials cause the 'high notes' of a fragrance to be evaporated when the wicking material is first exposed to the fragranced liquid, and the 'low notes' are evaporated thereafter which affects the user's experience.

Turning to drawbacks with known powered emanation devices, the effect of fractionation is particularly pronounced for powered emanation devices using a heater to effect emanation, such as a plug-in emanation device or the like. The phenomenon described above wherein changes in character for fragrances are noticeable as the 'high notes' of a fragrance are the first to be evaporated when the wicking material is first exposed to the fragranced liquid, and the 'low notes'

are evaporated thereafter which affects the user's experience is found to be particularly pronounced when a heater is used to drive the emanation of the fragrance.

Accordingly, it is an object of the present invention to provide a device that is capable of addressing the abovementioned performance drawbacks and other drawbacks that will be appreciated by a person skilled in the art.

Summary of Invention

According to a first aspect of the present invention there is provided therefore an emanation device for emanating a volatile liquid containing one or more active materials wherein the active material comprises at least one of: a fragrance; an insecticide; a fungicide; a pesticide; a sanitising material; and/or a pharmaceutical;

and wherein the emanation device comprises:

a housing;

a passive delivery mechanism;

a powered emanation means;

wherein the housing is arranged to support the passive delivery mechanism in spatial arrangement over the emanation means; and

wherein the delivery mechanism comprises:

a volatile liquid reservoir;

one or more capillary tubes in fluid communication with the reservoir at one end thereof wherein said one or more capillary tubes are in non-valved fluid communication with the reservoir; and

a nozzle located at the end of the or each capillary tube(s) remote from the reservoir wherein the or each nozzle is in non-valved fluid communication with the or each capillary tube(s).

In the context of the present invention "non-valved" should be understood as meaning that that component of the device has no mechanical features which enable it to regulate or adjust the flow of liquid therethrough.

In the context of the present invention "passive" should be understood as meaning that that the delivery mechanism is operable without a power source or some other means which drives the delivery of the volatile liquid to the emanation means; in other words the delivery mechanism of the present invention only requires gravity in order deliver volatile liquid to the emanation means.

According to a second aspect of the present invention there is provided therefore an emanation device comprising:

a housing;
a passive delivery mechanism;
a powered emanation means;
wherein the housing is arranged to support the passive delivery mechanism in spatial arrangement over the emanation means; and
wherein the delivery mechanism comprises:
a volatile liquid reservoir holding a volatile liquid containing one or more active materials wherein the active material comprises at least one of: a fragrance; an insecticide; a fungicide; a pesticide; a sanitising material; and/or a pharmaceutical;
one or more capillary tubes in fluid communication with the reservoir at one end thereof wherein said one or more capillary tubes are in non-valved fluid communication with the reservoir; and
a nozzle located at the end of the or each capillary tube(s) remote from the reservoir wherein the or each nozzle is in non-valved fluid communication with the or each capillary tube(s).

According to a third aspect of the present invention there is provided therefore a passive delivery mechanism for an emanation device according to the first aspect of the present invention, wherein the delivery mechanism is connectable, preferably releaseably connectable, to a housing of the emanation device and wherein the passive delivery mechanism comprises:
a volatile liquid reservoir holding a volatile liquid containing one or more active materials wherein the active material comprises at least one of: a fragrance; an insecticide; a fungicide; a pesticide; a sanitising material; and/or a pharmaceutical;
one or more capillary tubes in fluid communication with the reservoir at one end thereof wherein said one or more capillary tubes are in non-valved fluid communication with the reservoir;
a nozzle located at the end of the or each capillary tube(s) remote from the reservoir wherein the or each nozzle is in non-valved fluid communication with the or each capillary tube(s).

According to a fourth aspect of the present invention there is provided a method of providing a non-valved flow rate of volatile liquid between substantially 0.1 - 500 μ L/hr on to an emanation means, wherein the method comprises the steps of placing a device according to the second aspect of the present invention in a location where emanation of the volatile liquid is desired and causing the non-valved flow of liquid from the passive delivery mechanism toward the emanation means and activating said emanation means to emanate the volatile liquid into the surrounding environment.

The non-valved arrangement may provide a device that once the liquid is allowed to flow from the reservoir the liquid will flow substantially continuously from the reservoir into the capillary tube to the nozzle and in the form of droplets on to the emanation substrate at a non-valved flow rate of

between substantially 0.1 - 500 μ L/hr, and preferably between substantially 20 - 40 μ L/hr, and most preferably between substantially 26 - 34 μ L/hr.

With a non-valved passive emanation device, it is critical to provide the device with a flow rate that is suited to ensure a peak emanation delivery rate from the emanation substrate. If the flow rate is too low the emanation rate will also be low and potentially produce a non-uniform emanation rate from the emanation substrate due to the substrate being generally dry or semi-dry when the liquid contacts the substrate with thus causing the substrate absorb and only slowly release the liquid as well as potentially exposing the components of the liquid to fractionation as the liquid is carried by wicking/capillary action along the substrate. Conversely if the flow rate is too high the emanation rate may be too high which in the case of a fragranced liquid could be overpowering for a user. A high flow rate also the risk of the liquid pooling on the emanation substrate as the substrate becomes saturated with the liquid, in the case of volatile liquids that can present dangers to the surface on which the device is located since volatile liquids may pose a potential health and/or fire hazard as well as a staining hazard to the surface supporting the device. The present inventors have advantageously found the aforementioned flow rate of 20 - 40 μ L/hr to represent the peak flow rate to emanate the volatile liquid to ensure satisfactory emanation rate thereof and ensuring the uniform emanation of the liquid whilst substantially preventing any pooling of the liquid on the emanation substrate.

The mass of each droplet is preferably between substantially 0.1 - 500mg, and more preferably between substantially 0.5 - 70mg.

The inter-relationship of the various components of the delivery mechanism is critical in ensuring that the desired non-valved flow rate and droplet size is achieved.

The reservoir is preferably substantially completely enclosed to prevent the evaporation of volatile liquid therefrom. The reservoir is preferably provided with a vent hole that can be opened to permit the flow of volatile liquid from the reservoir without the build up of negative pressure or a vacuum in the headspace of the reservoir. The vent hole is preferably provided in a side wall or an upper cover of the reservoir above the max height of the volatile liquid retained therein to permit air to vent into the headspace of the reservoir above the volatile liquid. The vent hole is preferably provided with an area of between substantially $7.9 \times 10^{-3} - 1.9 \times 10^3 \text{mm}^2$, and even more preferably with an area of between substantially $0.8 - 3.1 \text{mm}^2$. The vent hole is preferably substantially cylindrical and provided with a diameter of between substantially 0.01 - 50mm, and even more preferably with a diameter of between substantially 1 - 2mm.

The vent hole may be covered by a removable seal member such that, once opened it shall remain open. Alternatively, the vent hole may be covered by a re-sealable sealing member which can be opened and re-sealed as desired by the user to, in effect, turn the emanation of volatile liquid from the device between a binary on and off position but without providing a user with the ability to select a position therebetween which could alter the non-valved flow rate.

The reservoir may be sized to retain a volume of volatile liquid between substantially 0.1 – 500ml, and preferably between substantially 10 – 40ml.

The reservoir may be shaped such that the volatile liquid head height therewithin is between substantially 0.1 – 100cm, and preferably between substantially 3 – 10cm; the liquid head height is defined within the context of the present invention as being the height of the liquid from the nozzle to the liquid-air surface in the reservoir.

The device and/or delivery mechanism may be provided with a mechanical boost means which is operable to increase the flow rate of the volatile liquid from the non-valved flow rate to an enhanced flow rate.

Preferably the mechanical boost means is in the form of an air pump connected to the reservoir which allows a user to pump air into the headspace of the reservoir to increase the air pressure thereof to at least temporarily increase the flow rate from the non-valved flow rate to the enhanced flow rate, once the user ceases further pumping the non-valved flow rate will resume once the air pressure in the head space equalises over a period of time.

Alternatively an auxiliary flow route for the volatile liquid may be provided, said auxiliary flow route being operable to being opened by a user to increase the flow rate to the enhanced flow rate before being closed and the flow rate being returned to the non-valved flow rate. The auxiliary flow route may be provided in the form of an aperture in the reservoir, possibly connected to a conduit, wherein the flow of volatile liquid therethrough is controlled by a valve that can be manipulated by a user. The auxiliary flow route would preferably be provided with a liquid exit orifice located substantially above the emanation substrate.

The auxiliary flow route may be connected to a auxiliary reservoir of volatile liquid which is adjacent to but not in liquid communication with the reservoir.

The enhanced flow rate may be between substantially 2 – 50 times greater than the non-valved flow rate, and preferably between substantially 2 – 5 times greater than the non-valved flow rate.

The reservoir may be provided in any shape, however, a substantially cylindrical shape is preferred. For substantially cylindrically shaped reservoirs they may be provided with a diameter of between substantially 1 – 50cm, but preferably with a diameter of between substantially 4 – 8cm, and may be provided with a depth of between substantially 0.1 – 100cm, but preferably with a depth of between substantially 0.5 – 2cm.

Preferably at least a portion of the reservoir is transparent to permit a user to see the level of volatile liquid held within, preferably substantially all of the reservoir is transparent.

Preferably the devices/delivery mechanisms according to the present invention are provided with a single capillary connected to the reservoir.

The or each capillary tube is preferably made of glass or plastic and may be substantially cylindrical although it could be provided in numerous other geometric shapes. The capillary tube(s) is preferably of a uniform shape and cross-section throughout its length. The capillary tube(s) may be provided with a length of between substantially 0.1 – 50cm, and preferably with a length of between substantially 3 – 10cm. In the most preferred embodiment the capillary tube(s) is/are substantially cylindrical and provided with an internal diameter of between substantially 1 - 1000 μ m, and preferably with an internal diameter of between substantially 75 - 100 μ m.

The capillary tube(s) may be provided with a filter to ensure that any contaminants in the volatile liquid do not inadvertently cause a blockage to liquid entering and moving along the capillary during use, thus, potentially affecting the flow rate.

The nozzle(s) is/are preferably provided with a substantially circular exit orifice having a diameter of between substantially 0.01 – 100mm, but preferably has a diameter of between substantially 0.4 – 2mm. The nozzle(s) may be provided with a cap to ensure that no volatile liquid is lost therefrom prior to use by a user.

The volatile liquid for use with the device/delivery mechanism of the present invention preferably possesses the at least one of, or more preferably two of, or most preferably all three of the following properties:

- viscosity between substantially 0.1 – 100cP, and preferably between substantially 1 – 5cP;
- density between substantially 0.1 – 10g/L, and preferably between substantially 0.8 – 1.1g/L;
- average surface tension between substantially 1 – 100mN/m, and preferably between substantially 1 – 50mN/m.

The emanation means is preferably provided in the form of a heater thermally connected to a heater plate which is operable to increase its temperature to accelerate the evaporation of the volatile liquid from the heater plate. Alternatively the heater plate could be provided in the form of an absorbent material such as a wick material which is capable of transporting the volatile liquid toward the heater to volatilise the liquid from the absorbent material.

In a preferred embodiment of the present invention, the absorbent material is pre-dosed with the volatile liquid held in the reservoir. To maintain the level of pre-dosing of the absorbent material the absorbent material may be covered in a removable protective film to prevent or substantially prevent the emanation of the liquid therefrom until the film is removed by a user before use. Alternatively or additionally, the whole device may be sealed in a protective atmosphere to reduce or limit any natural evaporation of the pre-dosed volatile liquid from the absorbent material until a user removes the protective atmosphere immediately prior to use. Such a protective atmosphere may be provided in the form of a sealed packaging or the like. The pre-dosing of the absorbent material has been found to be particularly advantageous as it ensures that when the non-valved flow of liquid from the reservoir on to the absorbent material commences, emanation from the material is immediately affected whereas without pre-dosing the material will, for an initial period of time, mainly absorb the liquid before emanating the liquid into the surrounding environment.

Alternatively, the emanation means is provided in the form of an ultrasonic transducer element, such as a piezo-actuated emanator wherein the volatile liquid drops directly on to the piezo emanator or on to a plate connected to said piezo-actuated emanator and volatilised therefrom once the emanator is activated.

The emanation means may be powered by mains-supplied electricity and/or be battery powered and/or be powered by solar cells located on the device, preferably the emanation means are battery powered however to afford greater portability over a device wherein the emanation means use mains-supplied electricity. Alternatively the device may be provided with a docking station which may be battery powered and/or mains electricity powered in order to provide a charge to batteries held within the device to power the emanation means such that the device may be removed from the docking station for improved portability.

The housing is preferably provided in the form of an open framework which is configured to suspend the reservoir such that the capillary and nozzle are held directly above a substantially central point of the emanation means. Whilst an open framework is preferred since a user will be able to monitor the progress of volatile liquid from the reservoir through the capillary tube and out

of the nozzle on to the emanation means, the framework may be totally or partially enclosed to improve the safe operation of the device by preventing a user from being able to interrupt the flow from the liquid from the nozzle to the emanation means.

The preferred volatile liquid used with the device/delivery mechanism/method of the present invention is fragranced liquid for use as an air freshener. The present invention has been found to be particularly advantageous compared with known emanation methods due to the nature of fragranced volatile liquids.

Brief Description of the Drawings

Embodiments of the invention will now be described, by way of example only, with reference to the following drawings in which:

Fig. 1 illustrates a side sectioned view of an emanation device;

Fig. 2 illustrates a perspective view of the emanation device; and

Fig. 3 illustrates a perspective view of a delivery mechanism for a passive emanation device.

Description of an Embodiment

Figs. 1 & 2 illustrate an emanation device 1 which is generally arranged to have a housing 2 provided in the form of framework 3 supporting a delivery mechanism 12 which contains a quantity of volatile liquid 5. The delivery mechanism 12 is supported over an emanation means 6. The delivery mechanism 12 has a reservoir 4 which is provided in this embodiment with a single capillary tube 7 which extends from a substantially central portion of the reservoir 4 toward the emanation means 6. At the remote end of the capillary tube 7 is located a nozzle 8 from which, in use, volatile liquid will drop towards the emanation means 6.

Specifically the delivery mechanism 12 is a passive mechanism as it is not powered by any form of propulsion or motor or electricity etc, rather it simply relies on the force of gravity to be operable and provide a non-valved flow rate. The delivery mechanism 12 is, importantly, non-valved in that there are no mechanical features of the delivery mechanism which can be altered to reduce the non-valved flow rate of liquid from the reservoir 4 to the emanation means 6 once the liquid has been allowed to flow, thus ensuring that the device is operating at an optimum flow rate or not operating at all. The optimum flow rate (the non-valved flow rate) for this device is 0.1 - 500 μ L/hr, and preferably between substantially 20 - 40 μ L/hr, and most preferably between substantially 26 - 34 μ L/hr. Between 26 - 34 μ L/hr is the optimum flow rate and this is achieved whilst maintaining the mass of each droplet at between substantially 0.1 - 500mg, and but preferably between substantially 0.5 - 70mg. Clearly the inter-relationship of the various

components of the device 1 are critical in ensuring that this optimum flow rate and droplet mass is achieved.

As shown in Figs. 1 & 2 the reservoir 4 is substantially completely enclosed which acts to prevent evaporation of volatile liquid 5 therefrom. The reservoir 4 has a vent hole 9 that can be opened to permit the flow of volatile liquid 5 from the reservoir 4 without the build up of negative pressure or a vacuum in the headspace of the reservoir. The vent hole 9 is provided in the upper cover of the reservoir. The vent hole 9 is covered by a re-sealable sealing member 10 which operates via a screw thread mechanism to allow it to be brought into and out of sealing engagement with an upper surface of the vent hole 9.

The reservoir 4 may be sized to retain a volume of volatile liquid between substantially 0.1 – 500ml, but in Figs. 1 & 2 it is sized to retain between substantially 10 – 40ml. The volatile liquid head height therewithin may be between substantially 0.1 – 100cm, but is shown as being between substantially 5 – 12cm.

The reservoir 4 may be provided in any shape, however, Figs. 1&2 show the reservoir 4 to be substantially cylindrical with a diameter of between substantially 4 – 8cm and a depth of between substantially 0.5 – 2cm.

The framework 3 is of an open configuration so that it does not obscure the reservoir 4 which is transparent, thus permitting a user to see the level of volatile liquid held within. The capillary tube 7 is also transparent which allows the user to monitor the progress of liquid therethrough on its journey toward the emanation substrate 6.

The capillary tube 7 is shown as being made of glass and having a substantially uniform cylindrical shape having an internal diameter of between substantially 75 - 100 μ m and a length between substantially 3 – 10cm. The capillary tube 7 ends at its lowermost portion with the nozzle 8 which is shown as having an exit orifice between substantially 0.4 – 2mm. The nozzle is shown as being surrounded by a capillary housing 11 which provides additional safety for the operation of the device but ensuring that the potentially delicate capillary tube 7 and nozzle 8 can not be accidentally interfered with by a user during normal operation. Furthermore, the capillary housing 11 offers the nozzle 8 a degree of shielding from air currents surrounding which may affect the flow rate of volatile liquid droplets leaving the nozzle. Although not shown, the capillary housing 11 and/or the nozzle 8 may be provided with a cap to ensure that no volatile liquid is lost therefrom prior to use by a user.

The emanation means 6 is provided in the form of an ultrasonic transducer powered by a piezo-actuator. The transducer is powered by batteries (not shown) and is operable to actuate at routine intervals in order to cause the break up of the volatile liquid drops dropped thereon into small particles having enough kinetic energy to travel into the surrounding environment.

Fig. 3 shows the delivery mechanism 12 which consists of a reservoir 4 which holds a quantity of volatile liquid 5 covered by a cap of the like (not shown), the reservoir 4 having a capillary tube 7 terminating in a nozzle 8. The delivery mechanism 12 could be used as a refill wherein it is replaceable within the housing 2 once the reservoir 4 held therewithin has been exhausted.

Examples are now described which illustrate the interoperation of the various parameters required to produce a delivery mechanism having the peak flow rates called for in the devices of the present invention.

Example 1

Capillary Length	46 mm
Inner Capillary Diameter	100 μ m
Nozzle Diameter	1.4 mm
Drop weight	11.5 mg
Reservoir Volume (fragrance)	30 mL
Liquid Head Height (from nozzle tip to top of liquid)	56.6 mm
Reservoir Diameter*	6 cm
Reservoir Depth (fragrance)*	1.06 cm
Vent Hole Diameter	1 mm
Fragrance Viscosity	3.2 cP
Fragrance Density	0.89 g/L
Fragrance Surface Tension	26.8 mN/m
Flow Rate	29.7 μ L/hr

Example 2

Capillary Length	100 mm
Inner Capillary Diameter	100 μ m
Nozzle Diameter	5.9 mm
Drop weight	29 mg
Reservoir Volume (fragrance)	30 mL
Liquid Head Height (from nozzle tip to top of liquid)	110.6 mm

Reservoir Diameter*	6 cm
Reservoir Depth (fragrance)*	1.06 cm
Vent Hole Diameter	1 mm
Fragrance Viscosity	3.2 cP
Fragrance Density	0.89 g/L
Fragrance Surface Tension	26.8 mN/m
Flow Rate	26.7 uL/hr

Both devices from examples 1 & 2 were operated for a continuous period until the fragranced volatile liquid was exhausted and the delivery mechanism of both devices consistently produced the flow rates and drop weights described above.

All of the features disclosed in this specification (including any accompanying claims, abstract and drawings), and/or all of the steps of any method or process so disclosed, may be combined in any combination, except combinations where at least some of such features and/or steps are mutually exclusive.

Each feature disclosed in this specification (including any accompanying claims, abstract and drawings) may be replaced by alternative features serving the same, equivalent or similar purpose, unless expressly stated otherwise. Thus, unless expressly stated otherwise, each feature disclosed is one example only of a generic series of equivalent or similar features.

The invention is not restricted to the details of the foregoing embodiment(s). The invention extends to any novel one, or any novel combination, of the features disclosed in this specification (including any accompanying claims, abstract and drawings), or to any novel one, or any novel combination, of the steps of any method or process so disclosed.

Claims

1. An emanation device for emanating a volatile liquid containing one or more active materials wherein the active material comprises at least one of: a fragrance; an insecticide; a fungicide; a pesticide; a sanitising material; and/or a pharmaceutical; and wherein the emanation device comprises:
a housing;
a passive delivery mechanism;
a powered emanation means;
wherein the housing is arranged to support the passive delivery mechanism in spatial arrangement over the emanation means; and
wherein the delivery mechanism comprises:
a volatile liquid reservoir;
one or more capillary tubes in fluid communication with the reservoir at one end thereof wherein said one or more capillary tubes are in non-valved fluid communication with the reservoir; and
a nozzle located at the end of the or each capillary tube(s) remote from the reservoir wherein the or each nozzle is in non-valved fluid communication with the or each capillary tube(s).
2. A device according to claim 1, wherein the device is configured to allow liquid on to the emanation means at a non-valved flow rate of between substantially 0.1 - 500 μ L/hr, and preferably between substantially 20 - 40 μ L/hr, and most preferably between substantially 26 - 34 μ L/hr.
3. A device according to claim 1 or claim 2, wherein the device is configured to allow the mass of each liquid droplet to be between substantially 0.1 - 500mg, and preferably between substantially 0.5 - 70mg.
4. A device according to any preceding claim, wherein the reservoir is provided with a vent hole.
5. A device according to claim 4, wherein the vent hole is covered by a re-sealable sealing member which can be opened and re-sealed.
6. A device according to any preceding claim, wherein the reservoir is sized to retain a volume of volatile liquid between substantially 0.1 - 500ml, and preferably between substantially 10 - 40ml.

7. A device according to any preceding claim, wherein the reservoir is shaped such that the volatile liquid head height therewithin is between substantially 0.1 – 100cm, and preferably between substantially 3 – 10cm.
8. A device according to any preceding claim, wherein the reservoir is substantially cylindrically shaped and have a diameter of between substantially 1 – 50cm, but preferably between substantially 4 – 8cm, and have a depth of between substantially 0.1 – 100cm, but preferably between substantially 0.5 – 2cm.
9. A device according to any preceding claim, wherein a single capillary tube is provided.
10. A device according to any preceding claim, wherein the capillary tube(s) is/are provided with a length of between substantially 0.1 – 50cm, and preferably with a length of between substantially 3 – 10cm.
11. A device according to any preceding claim, wherein the capillary tube(s) is/are substantially cylindrical and provided with an internal diameter of between substantially 1 - 1000 μ m, and preferably with an internal diameter of between substantially 75 - 100 μ m.
12. A device according to any preceding claim, wherein the nozzle(s) is/are provided with a substantially circular exit orifice having a diameter of between substantially 0.01 – 100mm, but preferably has a diameter of between substantially 0.4 – 2mm.
13. A device according to any preceding claim, wherein the emanation means is a heater.
14. A device according to any of claims 1-12, wherein the emanation means is an ultrasonic transducer.
15. A device according to any preceding claim, wherein the housing is provided in the form of an open framework which is configured to suspend the reservoir such that the capillary and nozzle are held directly above a substantially central point of the emanation means.
16. A passive delivery mechanism for an emanation device according to any preceding claim, wherein the delivery mechanism is connectable, preferably releaseably connectable, to a housing of the emanation device and wherein the passive delivery mechanism comprises:
a volatile liquid reservoir holding a volatile liquid containing one or more active materials wherein

the active material comprises at least one of: a fragrance; an insecticide; a fungicide; a pesticide; a sanitising material; and/or a pharmaceutical;
one or more capillary tubes in fluid communication with the reservoir at one end thereof wherein said one or more capillary tubes are in non-valved fluid communication with the reservoir;
a nozzle located at the end of the or each capillary tube(s) remote from the reservoir wherein the or each nozzle is in non-valved fluid communication with the or each capillary tube(s).

17. An emanation device comprising:

a housing;

a passive delivery mechanism;

a powered emanation means;

wherein the housing is arranged to support the passive delivery mechanism in spatial arrangement over the emanation means; and

wherein the delivery mechanism comprises:

a volatile liquid reservoir holding a volatile liquid containing one or more active materials wherein the active material comprises at least one of: a fragrance; an insecticide; a fungicide; a pesticide; a sanitising material; and/or a pharmaceutical;

one or more capillary tubes in fluid communication with the reservoir at one end thereof wherein said one or more capillary tubes are in non-valved fluid communication with the reservoir; and
a nozzle located at the end of the or each capillary tube(s) remote from the reservoir wherein the or each nozzle is in non-valved fluid communication with the or each capillary tube(s).

18. A mechanism or device according to either claim 16 or claim 17 respectively, wherein the volatile liquid possesses the at least one of, or more preferably two of, or most preferably all three of the following properties:

- viscosity between substantially 0.1 – 100cP, and preferably between substantially 1 – 5cP;
- density between substantially 0.1 – 10g/L, and preferably between substantially 0.8 – 1.1g/L;
- average surface tension between substantially 1 – 100mN/m, and preferably between substantially 1 – 50mN/m.

19. A method of providing a non-valved flow rate of volatile liquid between substantially 0.1 - 500 μ L/hr on to an emanation means, wherein the method comprises the steps of placing a device according to claim 17 in a location where emanation of the volatile liquid is desired and causing the non-valved flow of liquid from the passive delivery mechanism toward the emanation means and activating said emanation means to emanate the volatile liquid into the surrounding environment.

20. A passive emanation device substantially as described herein and with reference to the drawings.

1/2

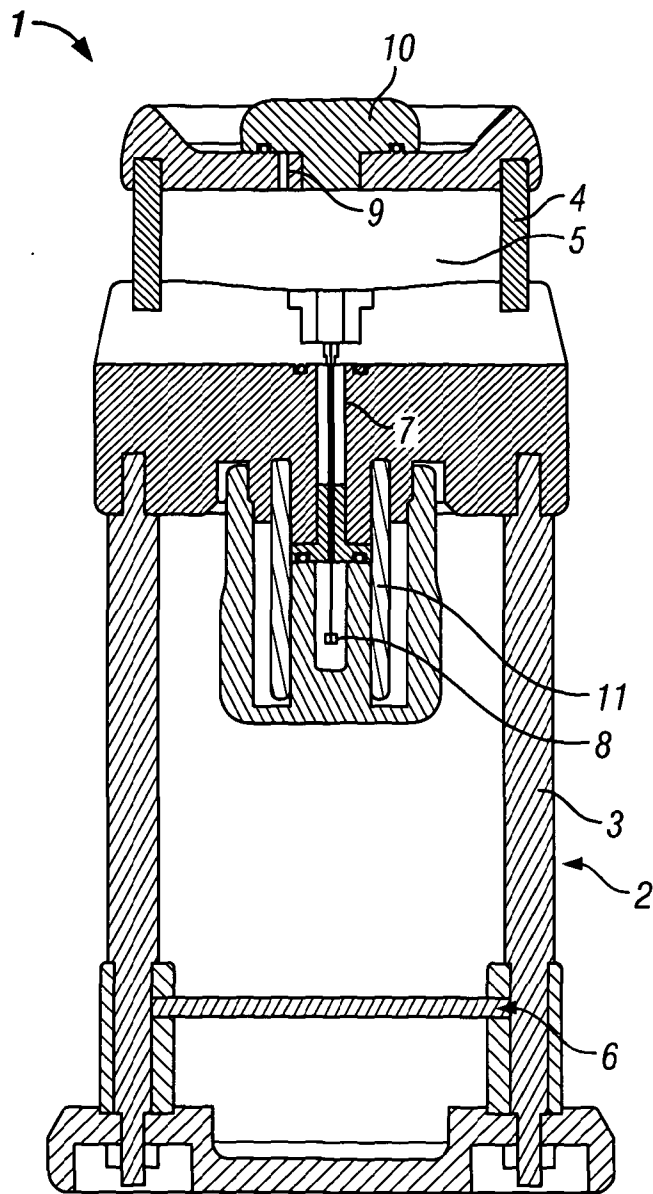

FIG. 1

2/2

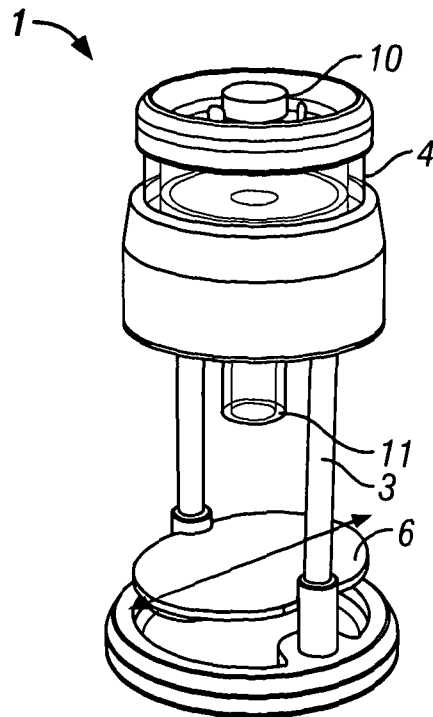

FIG. 2

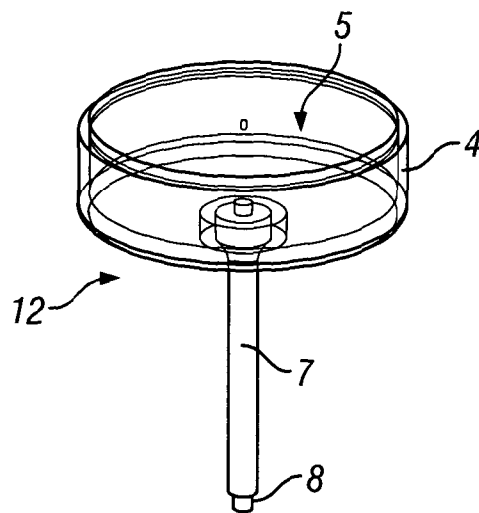

FIG. 3

INTERNATIONAL SEARCH REPORT

International application No
PCT/GB2011/051190

A. CLASSIFICATION OF SUBJECT MATTER
INV. A61L9/12 A01M1/20 A61L9/14
ADD.
According to International Patent Classification (IPC) or to both national classification and IPC

B. FIELDS SEARCHED
Minimum documentation searched (classification system followed by classification symbols)
A61L A01M
Documentation searched other than minimum documentation to the extent that such documents are included in the fields searched

Electronic data base consulted during the international search (name of data base and, where practical, search terms used)
EPO-Internal, WPI Data

C. DOCUMENTS CONSIDERED TO BE RELEVANT		
Category*	Citation of document, with indication, where appropriate, of the relevant passages	Relevant to claim No.
X	WO 2007/121997 A2 (BOEHRINGER INGELHEIM MICROPART [DE]; BLANKENSTEIN GERT [DE]; PETERS RA) 1 November 2007 (2007-11-01) figure 2	1-19
X	WO 2004/094071 A1 (DU PONT [US]; MCEWEN CHARLES NEHEMIAH [US]; HERRON WILLIAM JAMES [US];) 4 November 2004 (2004-11-04) figures 3,1	1-19
X	GB 2 357 973 A (RECKITT & COLMANN PROD LTD [GB]; RECKITT BENCKISER [GB]) 11 July 2001 (2001-07-11) figure 1 page 7, paragraph 2	1-19
	----- -/--	

Further documents are listed in the continuation of Box C.

See patent family annex.

* Special categories of cited documents :

<p>"A" document defining the general state of the art which is not considered to be of particular relevance</p> <p>"E" earlier document but published on or after the international filing date</p> <p>"L" document which may throw doubts on priority claim(s) or which is cited to establish the publication date of another citation or other special reason (as specified)</p> <p>"O" document referring to an oral disclosure, use, exhibition or other means</p> <p>"P" document published prior to the international filing date but later than the priority date claimed</p>	<p>"T" later document published after the international filing date or priority date and not in conflict with the application but cited to understand the principle or theory underlying the invention</p> <p>"X" document of particular relevance; the claimed invention cannot be considered novel or cannot be considered to involve an inventive step when the document is taken alone</p> <p>"Y" document of particular relevance; the claimed invention cannot be considered to involve an inventive step when the document is combined with one or more other such documents, such combination being obvious to a person skilled in the art.</p> <p>"&" document member of the same patent family</p>
--	--

Date of the actual completion of the international search 30 August 2011	Date of mailing of the international search report 07/09/2011
Name and mailing address of the ISA/ European Patent Office, P.B. 5818 Patentlaan 2 NL - 2280 HV Rijswijk Tel. (+31-70) 340-2040, Fax: (+31-70) 340-3016	Authorized officer Fischer, Michael

INTERNATIONAL SEARCH REPORT

International application No.
PCT/GB2011/051190

Box No. II Observations where certain claims were found unsearchable (Continuation of item 2 of first sheet)

This international search report has not been established in respect of certain claims under Article 17(2)(a) for the following reasons:

1. Claims Nos.:
because they relate to subject matter not required to be searched by this Authority, namely:

2. Claims Nos.: 20
because they relate to parts of the international application that do not comply with the prescribed requirements to such an extent that no meaningful international search can be carried out, specifically:
see FURTHER INFORMATION sheet PCT/ISA/210

3. Claims Nos.:
because they are dependent claims and are not drafted in accordance with the second and third sentences of Rule 6.4(a).

Box No. III Observations where unity of invention is lacking (Continuation of item 3 of first sheet)

This International Searching Authority found multiple inventions in this international application, as follows:

1. As all required additional search fees were timely paid by the applicant, this international search report covers all searchable claims.

2. As all searchable claims could be searched without effort justifying an additional fees, this Authority did not invite payment of additional fees.

3. As only some of the required additional search fees were timely paid by the applicant, this international search report covers only those claims for which fees were paid, specifically claims Nos.:

4. No required additional search fees were timely paid by the applicant. Consequently, this international search report is restricted to the invention first mentioned in the claims; it is covered by claims Nos.:

Remark on Protest

- The additional search fees were accompanied by the applicant's protest and, where applicable, the payment of a protest fee.
- The additional search fees were accompanied by the applicant's protest but the applicable protest fee was not paid within the time limit specified in the invitation.
- No protest accompanied the payment of additional search fees.

FURTHER INFORMATION CONTINUED FROM PCT/ISA/ 210

Continuation of Box II.2

Claims Nos.: 20

Claim 20 merely contains a reference to the description and the drawings without encompassing any searchable technical features. Therefore, the non-compliance with the substantive provisions of Art. 6 PCT is to such an extent, that no search was performed on claim 20. (Art. 17(2)(a)(ii) PCT, PCT Guidelines, 9.19 and 9.24).

The applicant's attention is drawn to the fact that claims relating to inventions in respect of which no international search report has been established need not be the subject of an international preliminary examination (Rule 66.1(e) PCT). The applicant is advised that the EPO policy when acting as an International Preliminary Examining Authority is normally not to carry out a preliminary examination on matter which has not been searched. This is the case irrespective of whether or not the claims are amended following receipt of the search report or during any Chapter II procedure. If the application proceeds into the regional phase before the EPO, the applicant is reminded that a search may be carried out during examination before the EPO (see EPO Guideline C-VI, 8.2), should the problems which led to the Article 17(2) declaration be overcome.

INTERNATIONAL SEARCH REPORT

International application No
PCT/GB2011/051190

C(Continuation). DOCUMENTS CONSIDERED TO BE RELEVANT		
Category*	Citation of document, with indication, where appropriate, of the relevant passages	Relevant to claim No.
X	DE 40 18 020 A1 (SHIMIZU CONSTRUCTION CO LTD [JP]) 6 December 1990 (1990-12-06) column 5, line 45 - column 6, line 11; figure 1 -----	1-19
X	WO 2009/142955 A1 (PROCTER & GAMBLE [US]; TOLLENS FERNANDO RAY [US]; TINLIN JAMES ROBERT) 26 November 2009 (2009-11-26) page 4, paragraph 4 - page 6, paragraph 2; figure 2b -----	1-19
X	WO 2006/004902 A1 (JOHNSON & SON INC S C [US]; VARANASI PADMA PRABODH [US]; ADAIR JOEL E) 12 January 2006 (2006-01-12) paragraph [0018]; figures 1,2 -----	1-19

INTERNATIONAL SEARCH REPORT

Information on patent family members

International application No

PCT/GB2011/051190

Patent document cited in search report	Publication date	Patent family member(s)	Publication date
WO 2007121997 A2	01-11-2007	EP 1849485 A1	31-10-2007
		EP 2010230 A2	07-01-2009
		JP 2009534267 A	24-09-2009
		US 2009184175 A1	23-07-2009

WO 2004094071 A1	04-11-2004	AU 2004233340 A1	04-11-2004
		BR PI0409765 A	09-05-2006
		CA 2519782 A1	04-11-2004
		CN 1777478 A	24-05-2006
		EP 1615725 A1	18-01-2006
		JP 4621663 B2	26-01-2011
		JP 2006524568 A	02-11-2006
		KR 20060003038 A	09-01-2006
		MX PA05011206 A	14-12-2005
		US 6729552 B1	04-05-2004

GB 2357973 A	11-07-2001	NONE	

DE 4018020 A1	06-12-1990	CA 2018181 A1	05-12-1990
		FR 2653022 A1	19-04-1991
		GB 2233230 A	09-01-1991
		IT 1248659 B	26-01-1995
		SE 9001819 A	06-12-1990

WO 2009142955 A1	26-11-2009	EP 2288390 A1	02-03-2011
		KR 20100131010 A	14-12-2010
		US 2009289127 A1	26-11-2009

WO 2006004902 A1	12-01-2006	AT 476203 T	15-08-2010
		AU 2005260607 A1	12-01-2006
		CA 2572746 A1	12-01-2006
		EP 1784231 A1	16-05-2007
		EP 2213312 A1	04-08-2010
		ES 2348586 T3	09-12-2010
		JP 2008504932 A	21-02-2008
		KR 20070053664 A	25-05-2007
