

(19)
(12)

(KR)
(Y1)

(51) 。 Int. Cl. 7
H04B 15/00

(45)
(11)
(24)

2001 10 31
20 - 0247619
2001 09 10

(21) 20 - 2001 - 0018528
(22) 2001 06 20
(62) 2000 - 0064698
: 2000 11 01

2000 11 01

(73) ()
232 - 3 2

(72) 5 271 - 4915/4

(74)
:

가 :

(54)

1.

2.

(Autoregressive) / (RF) (LMS) /

3.

(RF)

(IF) ; (Autoregressive) (LMS)
 (IF) , (IF) (IF) (RF)

4.

1

CDMA , , (LMS) ,

1

2 1

3 2

4 1

5 1

6 3 1

7 3 2

8 3 1

9

10 8

11 3 2

12 11

13 1

14 2

* *
 100: RF 102:
 104: RF 106: RF
 108: IF 110: RF
 112: RF 202: A/D
 204:
 206:
 208: 210: D/A
 302: 1 304:
 306: 2

(Autoregressive) (RF) (LMS) (IF) , / ,
 / , .
 ((CDMA) , 가 .
 , , 가 .
 , , 가 .
 CDMA (TDMA) , .
 (FDMA) (Eb/No) , , , 가 , 가 가 .
 , CDMA , 가 .
 (Power Control) , .

(RF) (Autoregressive) (LMS)
 () / ,
 (RF) (IF) ; (Autoreg
 (LMS) (IF) (IF)
 (RF) ; (IF) (IF)
 (RF)
 (IF) (RF)
 (IF) ; (Autoregressive), ((IF)
 (RF) (IF)
 (RF)
 1
 (RF: Radio Frequency)(, RF) (RF D
 (100), / (102),
 (RF Up Converter)(104)
 (102) - (A/D) (202), (DDC: Digi
 (204), (206), (DUC: Digital Up Convert
 (208), (D/A) (210) (2). ,
 (206) 1 (302), (304), 2 (306)
 , RF (RF Down Converter)(100) RF (106) IF (108) (5),
 RF (RF Up Converter)(104) RF (112) RF (110) (6).
 , RF (RF Down Converter)(100),
 (102), RF (RF Up Converter)(104)
 , RF (RF Down Converter)(100)

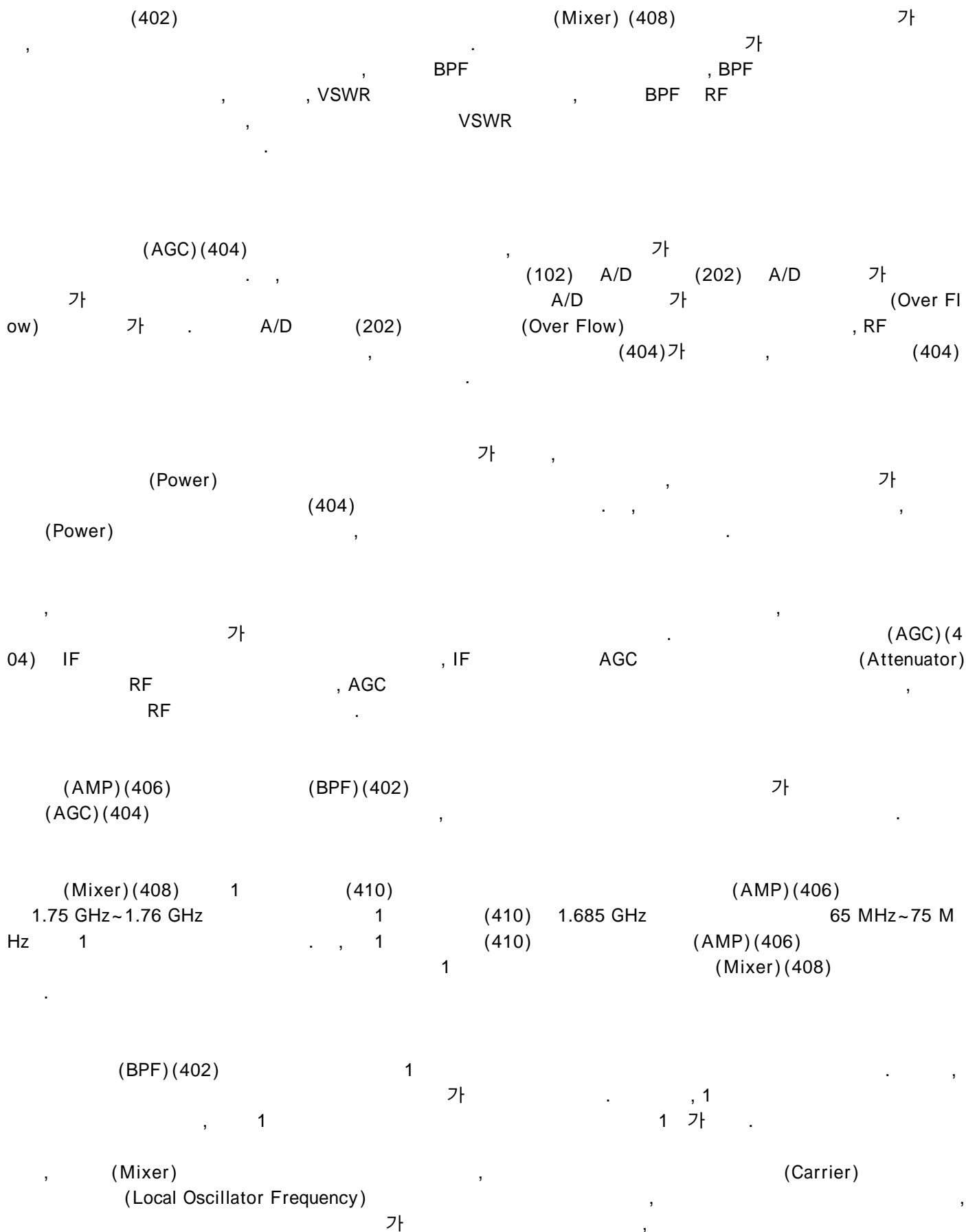

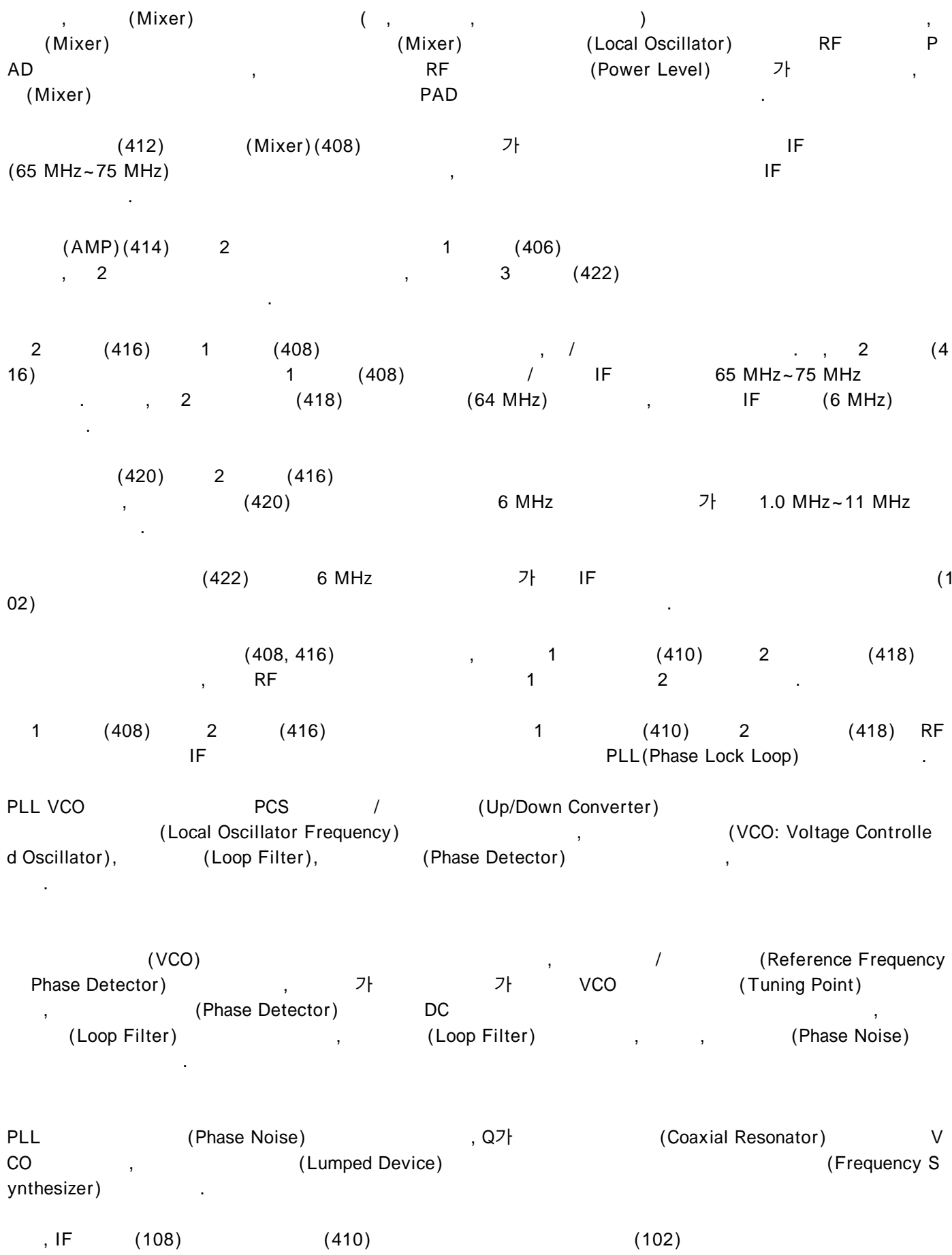

5 1

, RF (RF Up Converter) (104) (102)

RF (RF Down Converter) (104) D/A (210) RF (106) RF (110)

RF (112), RF (112) RF (110) (RF Down Converter) (100)

(102) D/A (210) RF (106) RF

(BPF: Band Pass Filter) (502) RF (104) RF (112) , RF (502)가 가

(104) , 가 6 MHz 가 10 MHz , RF (502)

가 (508) (Mixer) (504)

(516) '510'

RF (RF Up Converter) (104) 1 (512) 2 (506)가 , 1

(512) 2 (506) RF (110) IF RF 가

'410' '512'

1 '418' '506'

2

(Mixer) , '504' '510' , RF

(110)

, RF (RF Up Converter) (104) (Mixer) RF (100) ,

(504, 510) , 가 .

RF (RF Up Converter) (104) IF 2 (506) (504)

RF IF (108) 2 (418) (416)

(506) (102) 6 MHz IF 2

65 MHz~75 MHz

, '510' '504' 65 MHz~75 MHz 1 (512)

1.685 GHz RF 1750 MHz~1760 MHz

SAW (508) 가 가 가 가 가
 , 가 (Carrier) . SAW (508) 가 -23~ -24
 dB 가 (Matching) RF (Time Delay) 가 SAW 가 SAW
 , SAW (Front - end) 가 가 ,
 .
 (Attenuator)(514) , 가 ,
 , RF (110) 가 , 가
 ,
 RF (104) (518) RF (104) 가
 () , 50 80 ,
 가 .
 6 3 1 .
 , 1 (302) (600), (602)
 or) CPU, (MPU) (DSP: Digital Signalling Process)
 A/D (202) DDC(204) (600)
 A/D (202) DDC(204)
 , 1 , 1
 (600) (600) ,
 , 가
 ,
 (602) (6
 00) , , , ,
 (600) (304) , 2 , 1
 2 (306) .
 7 3 2 .

2 (CPU), (306) (MPU) (700) (702) (DSP), 2 (306)

(602) (700) (304) 1 (302)

(700) (702) 1 (302) (304)

9

8 (810, 812), 3 (802), 1 LMS (804) (304) (806, 8)

(304) (802)

가 (LMS: Least Mean Square)

1 (806) (802) (\hat{z}_k) (304) (z_k) (, 1)

(k)

1 (806) (806) LMS (k) ($\bar{\varepsilon}_k$) (\bar{z}_k) , 2 (\hat{z}_k)

(808) 1 (806)

1 (806) (k) LMS (804) (802)

가

6) 가 1 (80

(802) (802) (10

) 가 (ai,k)가 Tc (FIR Filter: Finite Impulse Response)

(IIR: Infinite Impulse Response Filter)

가 , 가 (1)

1

$$a_k = a_{k-1} + \frac{\mu}{\gamma_k} \rho(\varepsilon_k) X_k$$

a_k 가, μ 가, X_k (Sampling) 가, LMS (Mean Square Value) (Error) (Error)

(802) Tc 가 (FIR Filter: Finite Impulse Response) 가 (IIR Filter: Infinite Impulse Response) (802) LMS (304) CDMA

9

CDMA

A/D (Quantization Error)가, CDMA A/D (Saturation Error)가, (Over Flow) A/D (Dynamic Range)

CDMA

가

CDMA 0 dBm (Over Flow) LNA +/- 40 dBm

가 가

40 dBm (0 dBm) 가 +/- 20 dBm

10 8 (304)
 (ANF: Adaptive Noise Filter)(802) 8

(1006) (ANF: Adaptive Noise Filter)(802) (1000, 1002), (1004)

3 (1000) 8 2 (808) (k) (
 $\widehat{\varepsilon}_k$) (\widehat{z}_k) 가 () (
 \widehat{z}_k)

(\widehat{z}_k) Tc LMS
 가 (ai,k) (FIR Filter:
 Finite Impulse Response) (IIR: Infinite Impulse Response Filter) 가
 3 (1000) , 4 (1002) , 가 (1) .

11 3 2 .
 , (304) 8 , (1106, 1108), (1110, 1112),
 (1104), (1100), (1102) , 8
 (304) (1100)가 가 .

'0' 가 가 '0'
 가 , 가 ,
 가 , ,
 (304) (CPU), (MPU) (DSP)
 MS) (Autoregressive) (L
 CDMA

5 (1106) 1 (302) (Zk) (1104)
 (\widehat{z}_k) , (k)

5 (1106) CLMS , 6
 (1108) 5 (1106) (k) ($\widehat{\varepsilon}_k$) (1104) , 5 (11
 \widehat{z}_k) , (\widehat{z}_k) , 5 (11
 06) (k) (1100) .

(1100) (Vk) 가 (CLMS Algorithm)(1102)

(1104) 가

5 (1106) 5 가

(304) 가

(1104) (LMS) , 12 (1100) (CLMS : Compensated Adaptive LMS Algorithm)(1102)

(LMS)

가 가 가 (1100) 가

(1104) 가 (1100) 가 (CLMS Algorithm)(1102) (1100) 가

(ANF: Adaptive Noise Filter)(1104) 10 가 (ai,k)가 (IIR Filter: Infinite Impu (8 (Tc (FIR Filter: Finite Impulse Response Filter), (IIR F (12 ((Adaptive Compensated Filter)(1100) 10 , Zk가 (1104) 1 가 (c (208) Tc 가 가 (FIR Filter : Finite Impulse Response Filter), (IIR F (12 (i,k)가 (FIR Filter : Finite Impulse Response Filter) (IIR F (12 (2)).

(1100) 가

(1104) (1100) (304) CLMS (1102) CDMA

12

11

(Adaptive Compensated Filter)(1100) (1202, 1204), (1200),
 (1206)
 7 (1202) 11 5 (1106) (k) 8 (1204)
 (\hat{v}_i) (Vk)
 (1100) 7 (1202) (\bar{v}_i) Tc
 (1200) (1102) 가
 (Ci,k) (1206), (FIR Filter: Finite Impulse Re
 sponse Filter) (IIR Filter: Infinite Impulse Response Filter)
 8 (1204) 가 7
 , 가 (2)
 , 12 (Adaptive Compensated Filter)(1100)
 Zk(1)가 (1106) (k) (\hat{z}_k) 11 Tc
 (1104)

2

$$C_k = C_{k-1} + \frac{\mu_c}{\gamma_{k,c}} v_k E_k$$

, ck 가 , μ_c 가 , k,c , k
 , Ek
 (2) 가 (1) 가
 가 LMS 가
 , 가 (Error)
 (Error) (Mean Square Value)
 (1100) (1104)
 , (1104) 가
 13 1
 , (1 10)

CDMA RF IF (1300), IF A
 /D IF (1302), IF (Sampling Rate) (Ove
 r Sampling) FA , IF 1/4~1/8 (Decimation) (1304).
 , (Autoregressive) (LMS) ,
 (1306).
 , 1/4~1/8 (Decimation) IF IF
 (1310).
 , IF RF (1312).
 14 2 ,
 12). (1 7, 9

CDMA RF IF (1400), IF A
 /D IF (1402), IF (Sampling Rate) (Ove
 r Sampling) FA , IF 1/4~1/8 (Decimation) (1404).
 , (Autoregressive), (LMS) ,
 (1406).
 , 1/4~1/8 (Decimation) IF IF
 (1410).
 , IF RF (1412).
 , 가 , 가 가

가 .
 , CDMA CDMA
 , CDMA .
 , (Baseband) RF 가

CDMA
 , CDMA 가
 가 ,
 / ,
 가 가
 , RF/IF
 가 SDR(Software Defined Radio)
 (,)
 (Overlay) CDMA 가 ,
 , PCS , IMT - 2000 , CDMA
 가 .

(57)

1.

(RF) (IF) ;
 (Autoregressive) (LMS) (IF) , (IF)
 ;
 (IF) (RF)

2.

1 ,
 ,
 (A/D) ; (IF) -

DC); (D

(Autoregressive) (LMS)

;

(DUC);

(IF)

(D/A)

3.

2

(D/A)

1

(Autoregressive) (LMS)

1

1

2

4.

3

1

;

(D/A)

2

5.

3

4

1 1 ;
 1 2 ;
 1 가 가
 ;
 2 , 가 가

6.

(RF) (IF) ;
 (Autoregressive), (LMS) (IF) ;
 (IF) (RF)

7.

6 ,
 (A/D) ; (IF) -
 DC); (D)
 (Autoregressive), (LMS) ,
 ;
 (DUC);

(IF)

- (D/A)

8.

7 ,

,

1 , - (D/A)
;

(Autoregressive), (LMS) , 1
;

1 2

9.

8 ,

1 ,

,
;

, - (D/A)
2

10.

8 9 ,

,

1 1 ;

가 ; 1 가 ,

1
2 ;
1 가
2 가
2 가

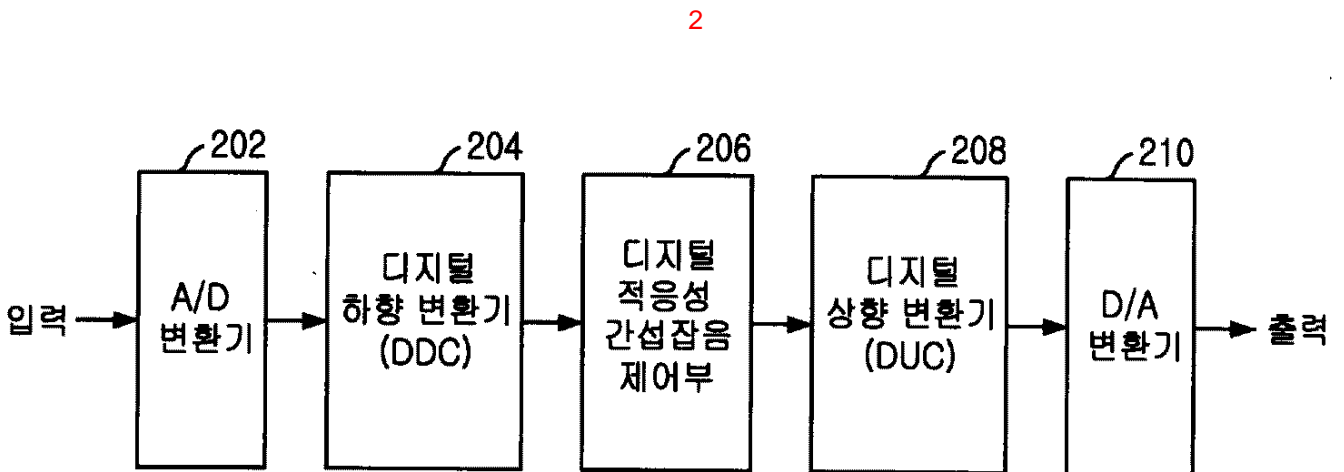
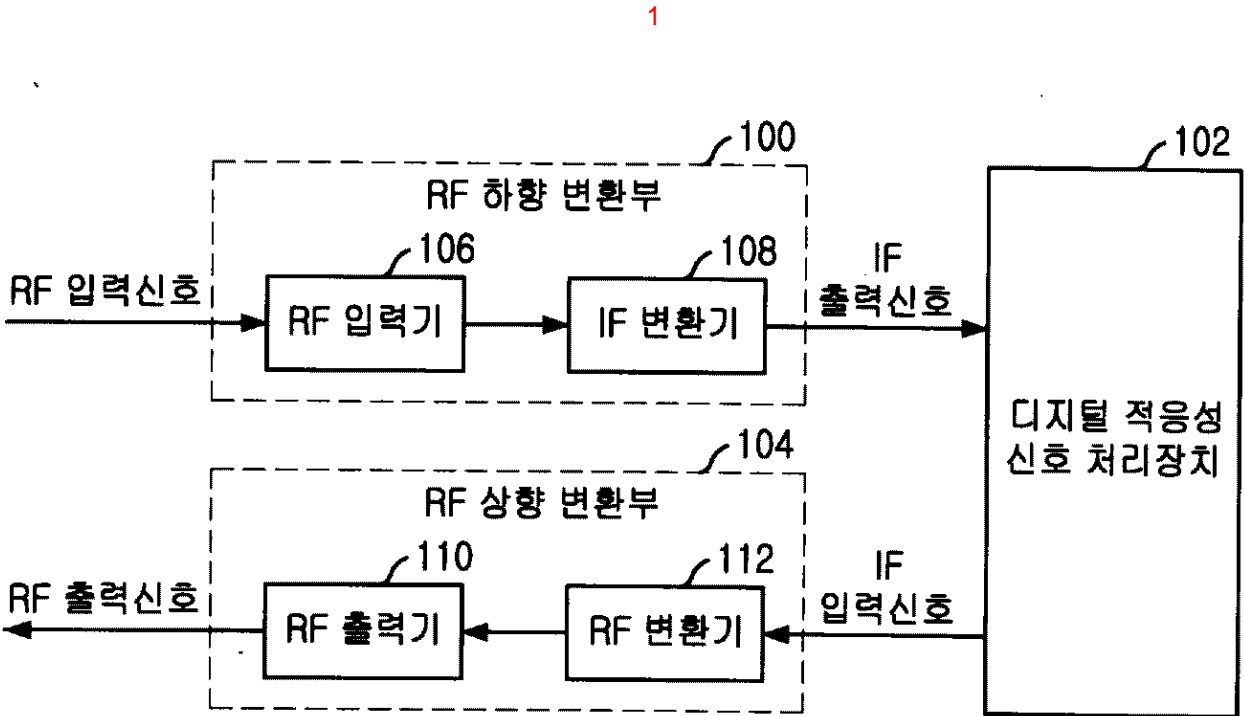

3

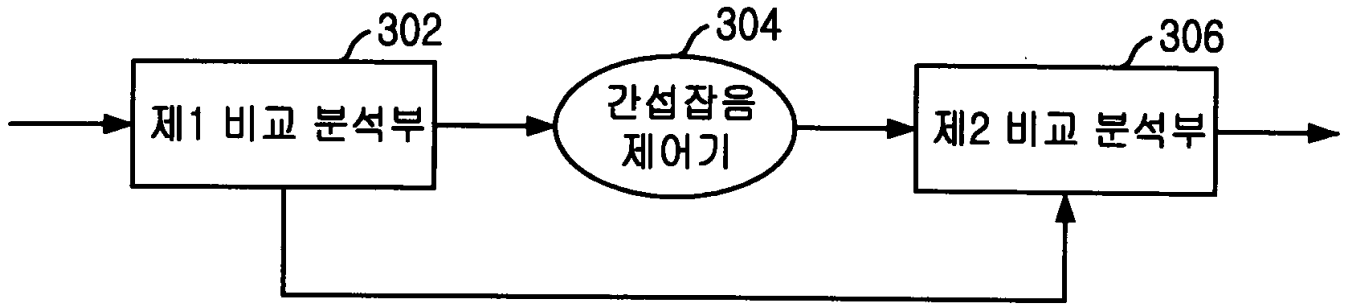

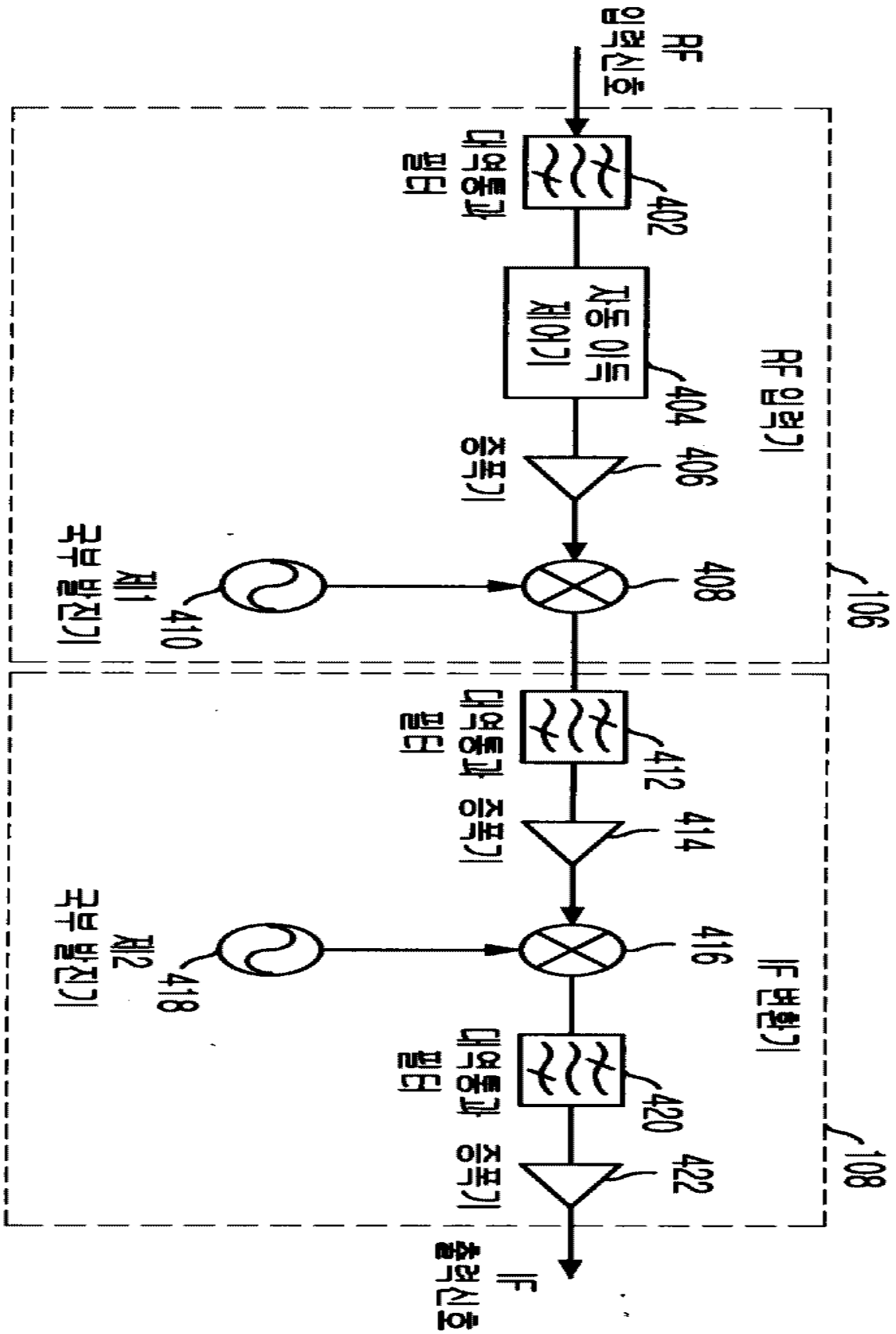

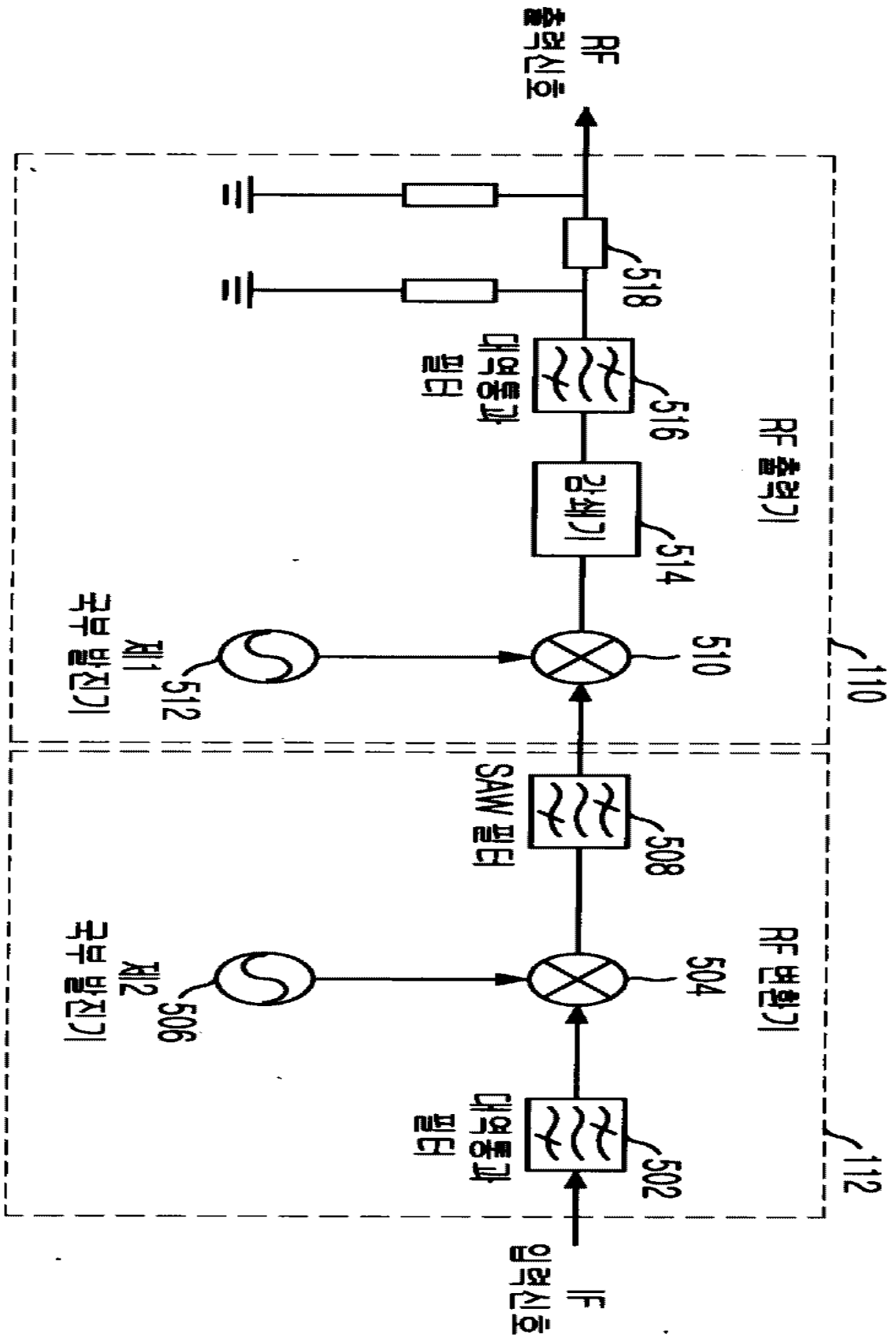

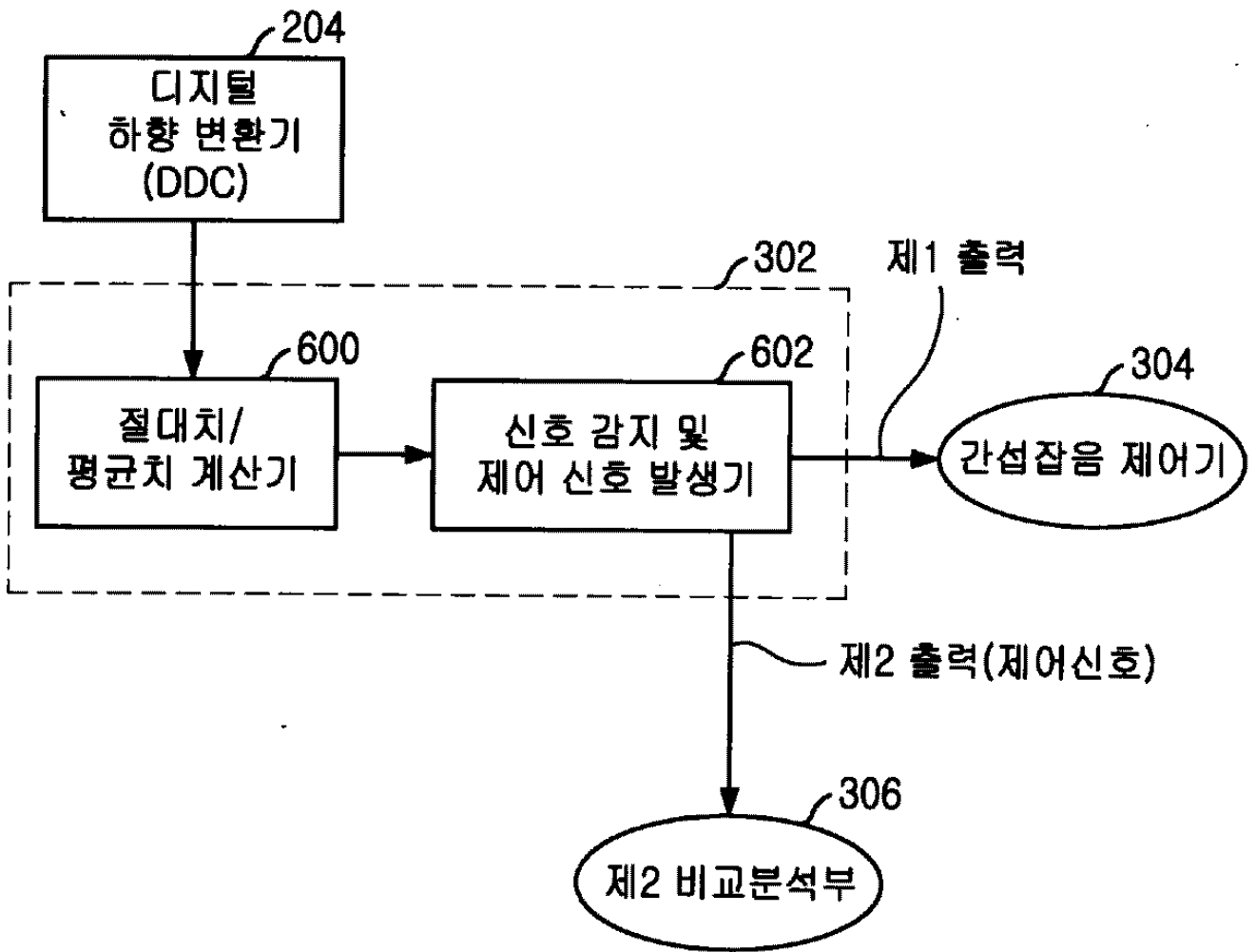

7

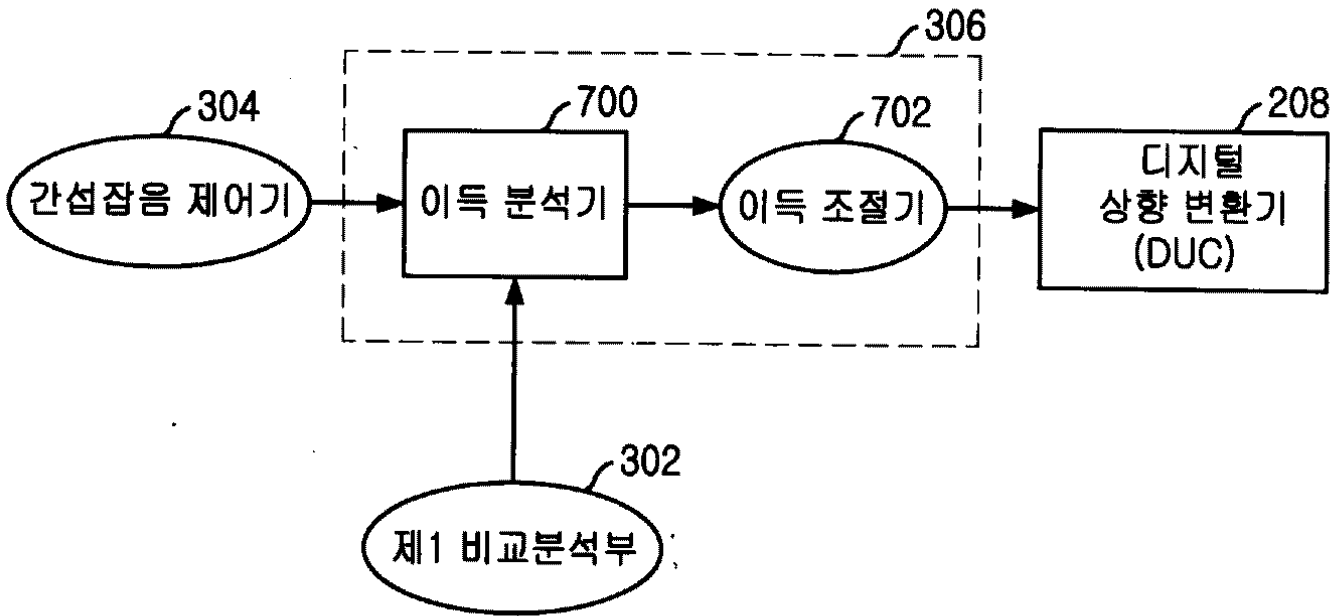

8

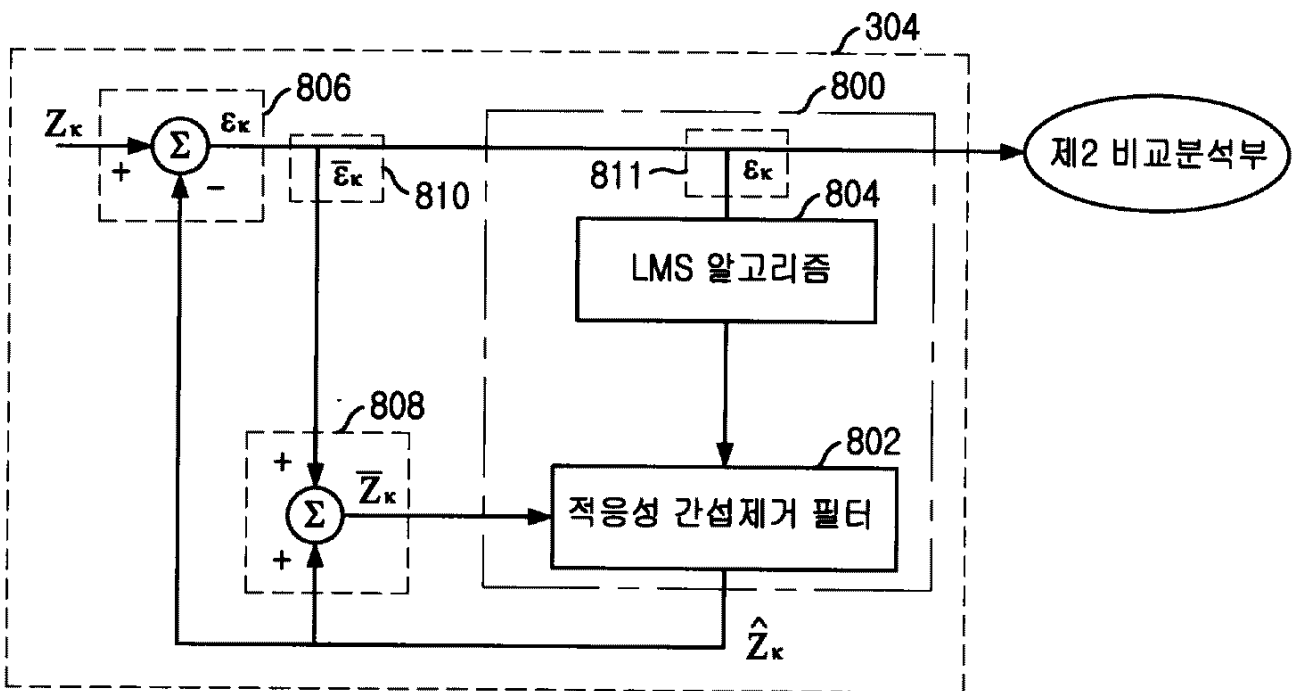

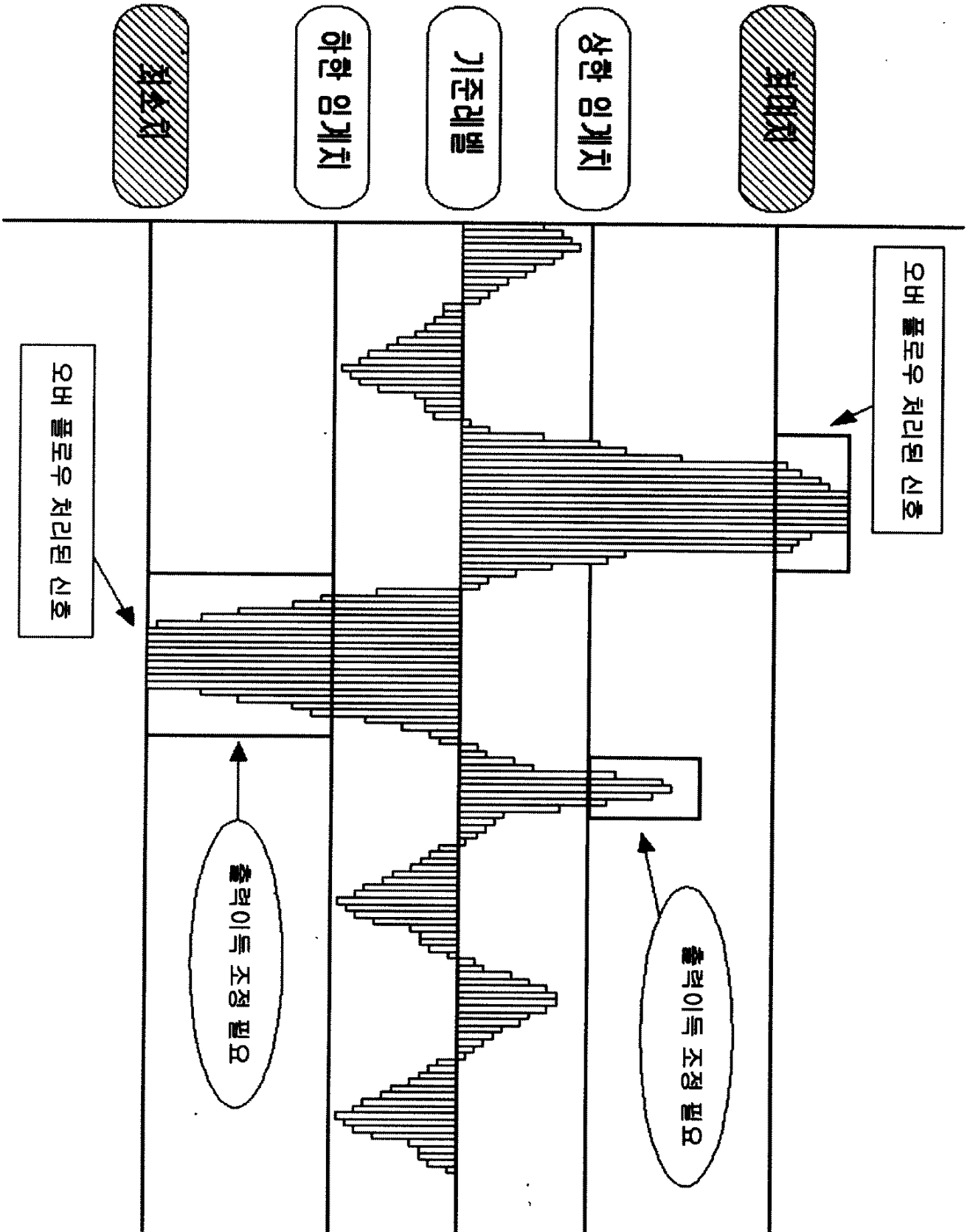

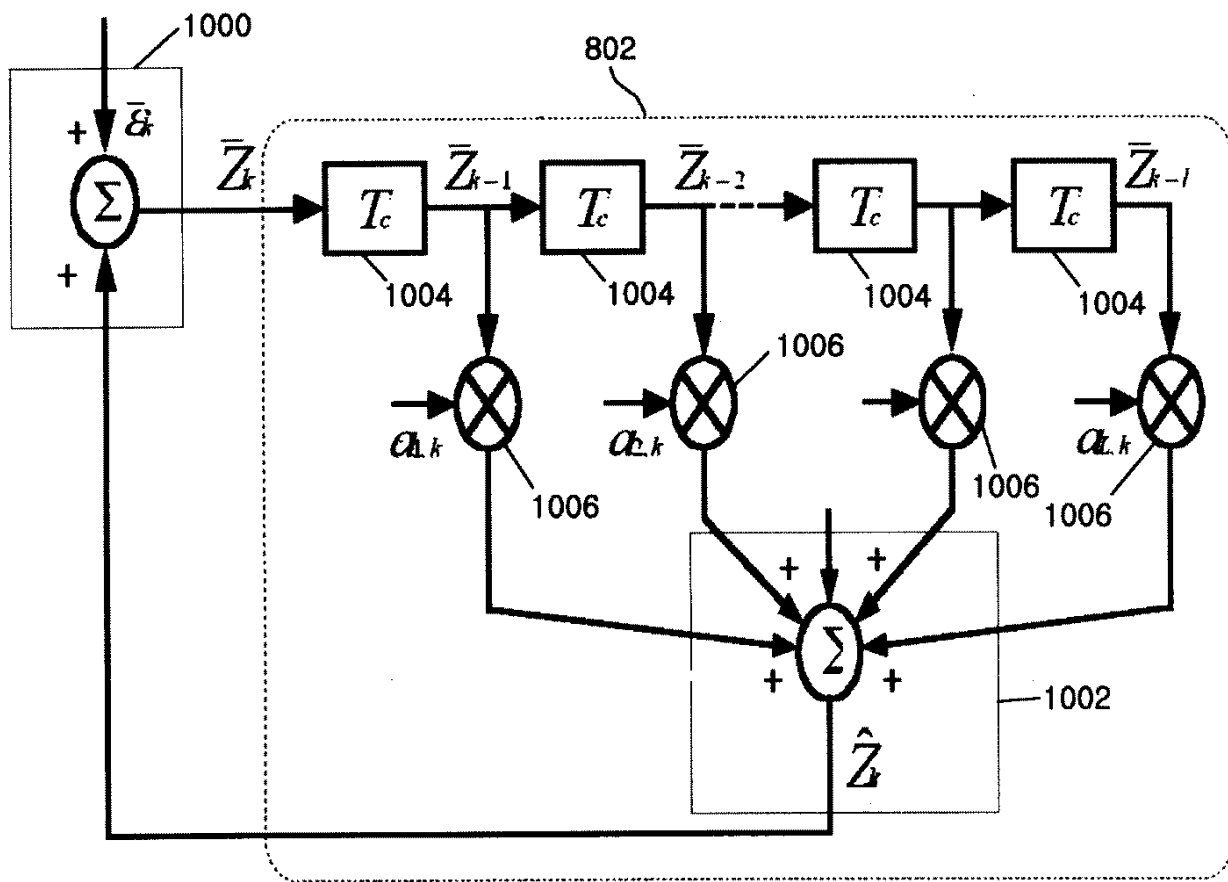

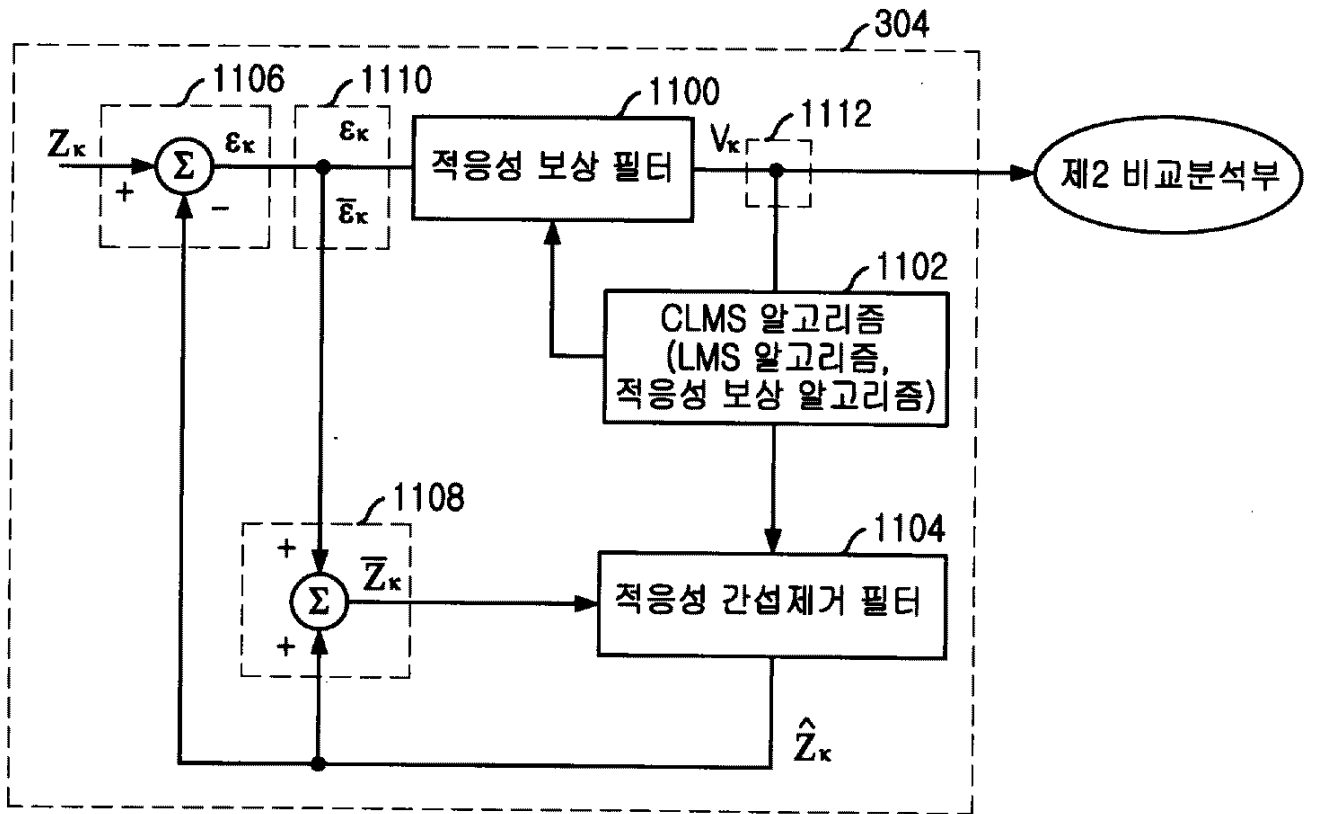

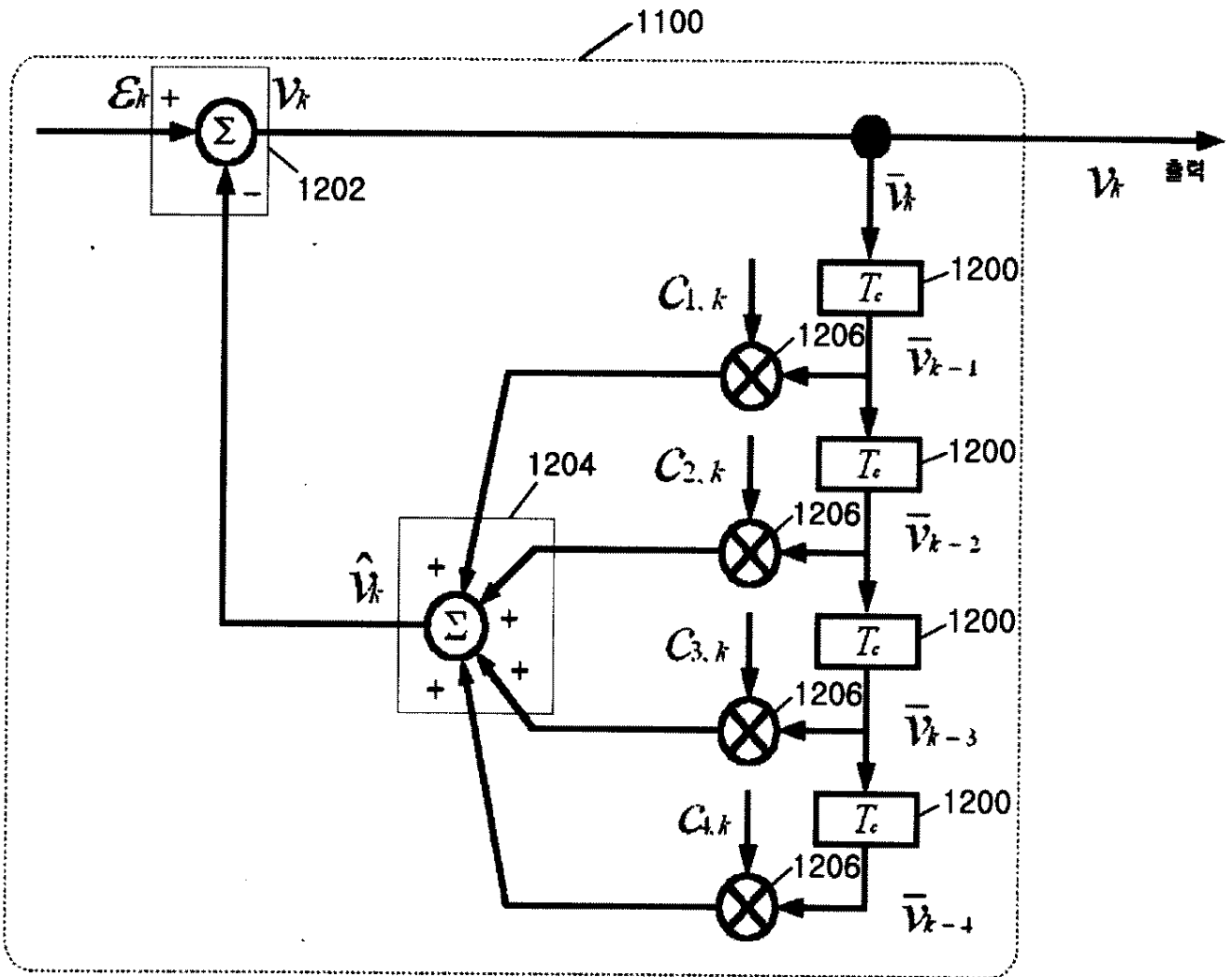

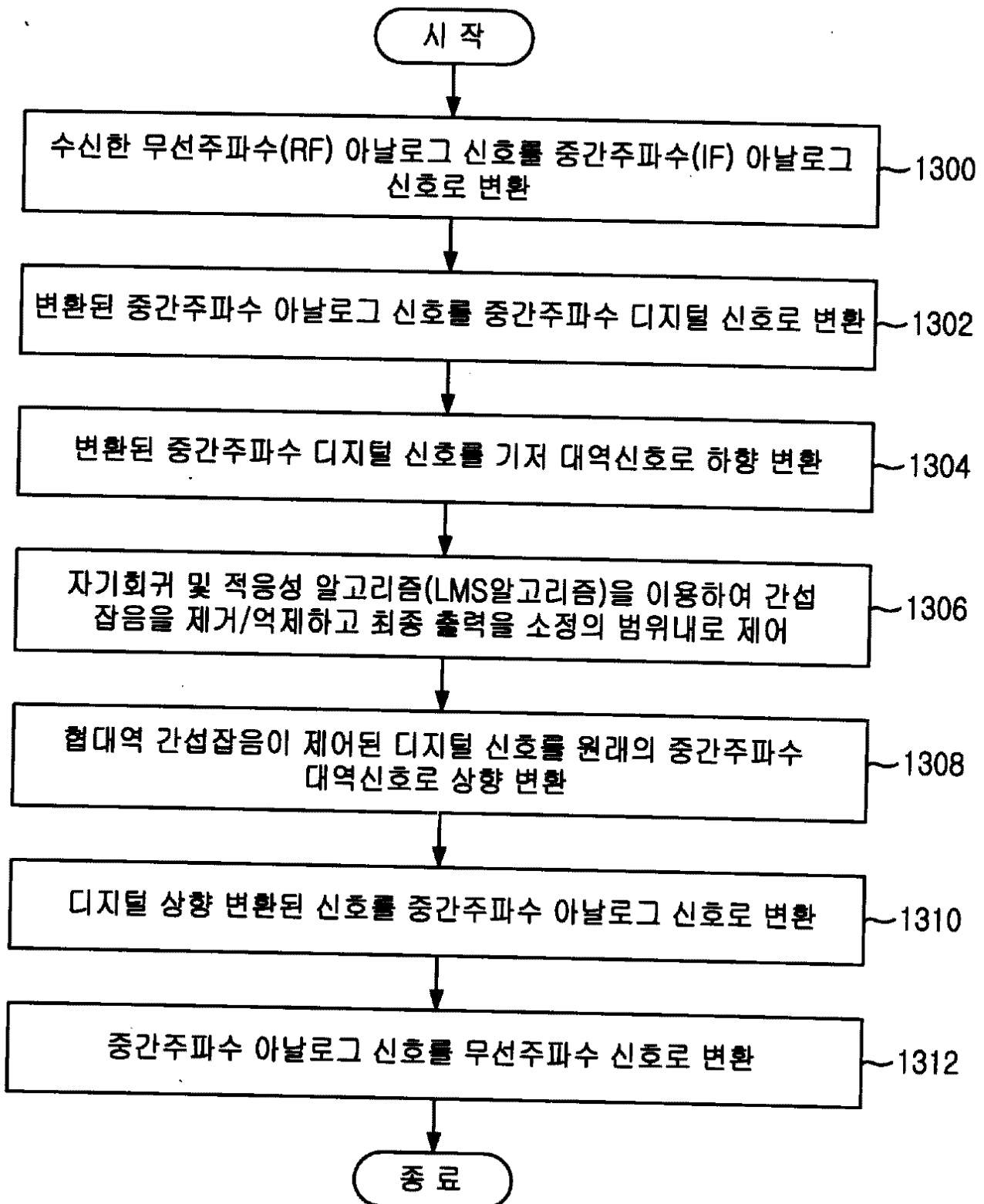

14

