

(19) World Intellectual Property Organization
International Bureau



(43) International Publication Date
28 March 2002 (28.03.2002)

PCT

(10) International Publication Number
WO 02/25058 A1

- (51) International Patent Classification⁷: E21B 43/04, 43/267, 43/14
- (71) Applicant (for FR only): SERVICES PETROLIERS SCHLUMBERGER [FR/FR]; 42, Rue Saint Dominique, F-75007 Paris (FR).
- (21) International Application Number: PCT/US01/29393
- (71) Applicant (for CA only): SCHLUMBERGER CANADA LIMITED [CA/CA]; 525 - 3rd Avenue, SW, Calgary, Alberta T2P 064 (CA).
- (22) International Filing Date: 20 September 2001 (20.09.2001)
- (71) Applicant (for AM, AT, AZ, BY, DE, DK, HR, IT, KG, KR, KZ, MD, NO, NZ, PL, RO, RU, TJ, TM, UA, ZA only): SCHLUMBERGER TECHNOLOGY B.V. [NL/NL]; Parkstraat 83-89, NL-2514 JG The Hague (NL).
- (25) Filing Language: English
- (71) Applicant (for GB, JP, NL only): SCHLUMBERGER HOLDINGS LIMITED [/]; P.O. BOX 71, Craigmuir Chambers, Tortola (VI).
- (26) Publication Language: English
- (72) Inventors; and
- (75) Inventors/Applicants (for US only): PARLAR, Mehmet [US/US]; 5451 Santa Chase Lane, Sugar Land, TX 77479 (US). PRICE-SMITH, Colin, J. [GB/US]; 3622 Double Lake Drive, Missouri City, TX 77459 (US). TIBBLES, Raymond, J. [US/US]; 3511 Battle Creek Drive, Missouri
- (30) Priority Data: 60/233,911 20 September 2000 (20.09.2000) US
- (71) Applicant (for AE, AG, AL, AU, BA, BB, BE, BF, BG, BJ, BR, BZ, CF, CG, CH, CI, CM, CN, CO, CR, CU, CY, CZ, DM, DZ, EC, EE, ES, FI, GA, GD, GE, GH, GM, GN, GQ, GR, GW, HR, HU, ID, IE, IL, IN, IS, KE, KP, LC, LK, LR, LS, LT, LU, LV, MA, MC, MG, MK, ML, MN, MR, MW, MX, MZ, NE, PH, PT, SD, SE, SG, SI, SK, SL, SN, SZ, TD, TG, TR, TT, TZ, UG, UZ, VN, YU, ZW only): SOFITECH N.V. [BE/BE]; 140 Rue de Stalle, B-1180 Brussels (BE).

[Continued on next page]

(54) Title: METHOD FOR GRAVEL PACKING OPEN HOLES ABOVE FRACTURING PRESSURE

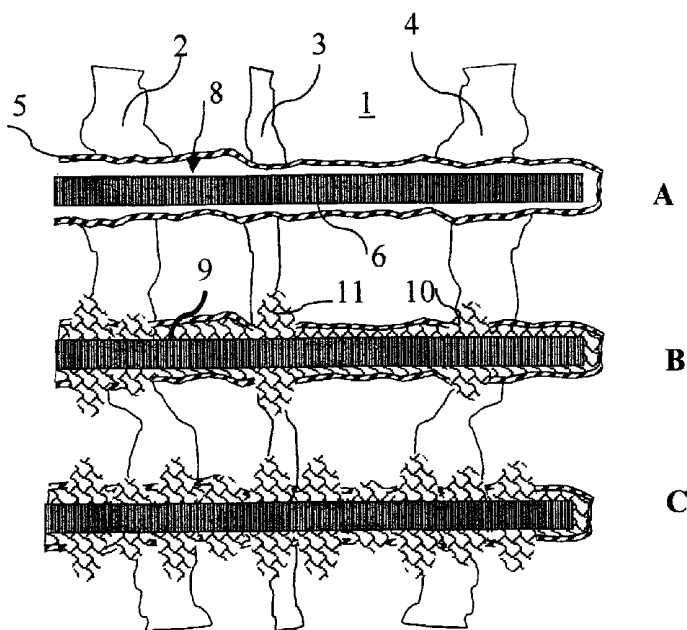

(57) Abstract: The present invention provides a method for gravel packing an open-hole wellbore having a filter cake, comprising pumping a gravel slurry into a first portion of an annular between the wellbore and a screen, at a sufficient rate and pressure to form at least a first fracture and diverting the gravel slurry to a second portion of said annular through alternate flowpaths while providing hydraulic isolation between the first and the second portion of said interval thereby preventing flowback from said second portion to said first portion and resulting extension of the first fracture and forming a second fracture in said second portion of said interval.

WO 02/25058 A1



City, TX 77459 (US). **HURST, Gary, D.** [US/US]; 111 Loganberry #411, Lake Jackson, TX 77566 (US).

(74) Agent: SCHLATHER, Stephen, F.; SCHLUMBERGER TECHNOLOGY CORPORATION, 110 Schlumberger Drive, MD-1, Sugar Land, TX 77478 (US).

(81) Designated States (national): AE, AG, AL, AM, AT, AU, AZ, BA, BB, BG, BR, BY, BZ, CA, CH, CN, CO, CR, CU, CZ, DE, DK, DM, DZ, EC, EE, ES, FI, GB, GD, GE, GH, GM, HR, HU, ID, IL, IN, IS, JP, KE, KG, KP, KR, KZ, LC, LK, LR, LS, LT, LU, LV, MA, MD, MG, MK, MN, MW, MX, MZ, NO, NZ, PH, PL, PT, RO, RU, SD, SE, SG, SI, SK, SL, TJ, TM, TR, TT, TZ, UA, UG, US, UZ, VN, YU, ZA, ZW.

(84) Designated States (regional): ARIPO patent (GH, GM, KE, LS, MW, MZ, SD, SL, SZ, TZ, UG, ZW), Eurasian patent (AM, AZ, BY, KG, KZ, MD, RU, TJ, TM), European patent (AT, BE, CH, CY, DE, DK, ES, FI, FR, GB, GR, IE, IT, LU, MC, NL, PT, SE, TR), OAPI patent (BF, BJ, CF, CG, CI, CM, GA, GN, GQ, GW, ML, MR, NE, SN, TD, TG).

Published:

- *with international search report*
- *before the expiration of the time limit for amending the claims and to be republished in the event of receipt of amendments*

For two-letter codes and other abbreviations, refer to the "Guidance Notes on Codes and Abbreviations" appearing at the beginning of each regular issue of the PCT Gazette.

Method for Gravel Packing Open Holes Above Fracturing Pressure

Technical Field of the Invention

[0001] The present invention relates to the completion of hydrocarbon wellbore sand control
5 and more particularly to gravel-pack completion in horizontal or highly deviated open-hole
wells.

Background of the Invention

[0002] In the recovery of hydrocarbons from subterranean formations, horizontal or highly
deviated wells are considered as a proven method of maximizing hydrocarbon productivity.
10 Many horizontal or highly deviated wells are not cased and therefore the completion cost is
small compared to cased-hole wells. In unconsolidated formations however, sand control
measures need to be implemented to prevent wellbore collapse, hardware failure and optimize
well deliverability.

[0003] A very common practice in the oil and gas industry for controlling sand migration into
15 wells penetrating loosely consolidated formations includes placement of gravel pack to hold
formation sand in place. The gravel pack is typically deposited around a perforated liner or
screen. The gravel pack filters the sand while still allowing formations fluid to flow through the
gravel, the screen and a production pipe.

[0004] Highly deviated or horizontal wells are in most cases completed open-holes essentially
20 because of higher well productivities and lower completion cost. In the past, such wells were
typically completed with stand-alone screens so that the well will collapse around the screen.
However the screen may be in some areas plugged by formation sand. Therefore, it might be
desirable to protect the screen with a gravel pack that further stabilizes the formation face.

[0005] Consequently, gravel packing of open-hole horizontal wellbores is increasingly used for
25 completing horizontal wells (in the remaining part of this document, the term "horizontal wells"
is also meant to include highly deviated wells).

[0006] Typically, horizontal gravel packing is achieved with water packing. Water packing is a
two-stage process using low concentration of gravel in brine. In a first wave, called the α wave,
the lower section of the well is packed until either the well extremity is reached or a premature

screen-out occurs. The premature screen-out is due to the formation of a bridge due to increased leakoff rates and thus decreased return rates. Then, the top section of the well is packed by the second or β wave. Water packing mainly relies on the ability to maintain high circulation rates. Indeed gravel transport essentially depends on velocity and turbulent flow rather than viscosity.

5 Therefore the success of gravel placement relies on the existence of a low-permeability filter cake that minimizes losses of gravel packing fluids. As discussed in a SPE paper 38640 presented at a symposium sponsored by the Society of Petroleum Engineers held in Rio de Janeiro, Brazil, during 30 August-3 September of 1997, fracturing must be avoided at all cost in such an operation. Otherwise, a catastrophic loss of gravel-pack fluid occurs, resulting in the

10 formation of bridges and incomplete packing below the bridge. Bearing in mind that intervals as long as 10,000 feet may have to be performed in horizontal wells, the formation of a bridge near the heel of the interval (the portion of the interval closest to the surface of the wellbore) could indeed result in a dramatic decrease of the well productivity.

[0007] To alleviate the difficulties raised by long or inclined intervals, "alternate paths" tools

15 have been proposed. Such tools include perforated shunts adapted to receive the gravel slurry as it enters the annulus around the screen. Those shunts provide alternate paths that allow the gravel slurry to be still delivered even though a bridge forms before the operation is completed. A complete description of a typical alternate-path gravel pack tool and how it operates can be found for instance in U.S. Patent No. 4,945,991. Several improvements to the operation

20 technique and to the tools have been proposed for instance in U.S. Patent No. 4,945,991; 5,082,052; 5,113,935; 5,341,880; 5,419,394; 5,435,391; 5,476,143; 5,515,915 and 6,220,345. This technique has been successfully applied for horizontal wells

[0008] Unlike water packing, gravel packing with the shunt technique proceeds from heel to toe, based on visual observations in large-scale yard tests (see for example, Figure 3 in Journal of

25 Petroleum Technology, Jan. 2000, pp. 50-58). In fact, based on large-scale yard tests, the packing with this technique takes place with successive formation of bridges as discussed in the JPT article referred to earlier. Furthermore, once a segment of screen/formation annulus and the shunt ports serving that section are packed, diversion of slurry into the next segment of shunt tubes occurs due to high resistance to flow through the packed shunt ports. Thus, the success of

30 gravel packing with this technique is controlled by the resistance to slurry flow through the shunt ports, and independent of either the formation properties or the existence of a filtercake. This has been proven repeatedly with field applications where gravel packing of long intervals has been accomplished without any returns, as also evidenced by large scale yard testing.

[0009] After the placement of the gravel, it is desirable to remove the filter cake formed during the drilling or cleaning process to achieve a uniform flow profile along the horizontal well and avoid for instance premature aging of the screen. Cake clean-up has been conventionally done is a separate, that involves pulling the work string out of the hole, running in with the production
5 tubing, tripping in with coiled tubing in order to displace the remaining gravel pack carrier fluid and spotting of a breaker solution. This cleaning process is time consuming, costly and often of poor efficiency. It is therefore desirable to provide a new way of completing open hole wellbores.

10

Summary of the Invention

[0010] This invention proposes a system and a process whereby gravel packing of open-hole completions can be done above fracturing pressure in order to bypass filtercake damage, where the latter is typically on the order of several millimeters to several inches. The proposed approach is novel and significantly different than conventional fracturing and frac-packing
15 techniques, where pad injection and high injection rates during both the pad and the slurry injection are required in order to keep the fracture open and thus keep the fracture propagation.

[0011] The present invention provides a method for completing an interval of an open-hole wellbore penetrating a subterranean formation, said wellbore being communicating with the formation by way of an interface that comprises at least a filter cake invaded zone, said method
20 comprising locating a workstring in the sand screen inside the wellbore, thereby forming an annular between the sand screen and the wellbore; pumping a gravel slurry into said annular at a sufficient rate and pressure to form at least a first fracture in a first portion of said interval; and diverting the gravel slurry to at least a second portion of said annular through alternate flowpaths while providing hydraulic isolation between the first and the second portion of said
25 interval thereby preventing flowback from said second portion to said first portion and resulting extension of the first fracture and forming a second fracture in said second portion of said interval.

[0012] The method of the present invention is mainly applicable for horizontal or highly deviated wells but could actually be also applicable to all types of open-hole well though it is
30 particularly appropriate for the completion of long interval, extending for instance over 300 feet and up to 1,500 feet or more if needed.

[0013] According to a preferred embodiment, at least three fractures are created. Indeed, the operation will be usually designed to create as many fractures as possible over the interval. However, a key element of the invention is that those fractures are not designed to be wide and/or long.

5 [0014] Consequently, and unlike conventional fracturing or so called frac-and-pack techniques, the proposed technique does not involve pad stages or ramping of proppant concentration, but only requires fracture initiation pressure to be exceeded during pumping. To that aspect it is worth noting that a treatment according to the invention will typically be designed to create a fracture of no more than a few inches. The pumping step will be conducted to provide fracture
10 that, theoretically, extend radially outward from the wellbore of no more than about 10 feet, preferably ranging between 3 and 100 inches, and most preferably between about 5 and about 50 inches. To that aspect, it is worth noting that frac-and-pack operations are usually designed to create fractures from about 50 to about 100 feet.

[0015] Similarly, the fracture width is controlled so that it preferably ranges between 0 and ½
15 inch. Consequently, the total volume placement of gravel slurry is usually about twice the volume of the screen/wellbore annular, and in most cases ranges between 1.5 and 2.5 times said volume.

[0016] The invention provides number of benefits, namely eliminates the need of cake removal treatment and the associated risks of damaging the sand screen in particular when aggressive
20 filter cake breakers such as based on chloride acid are used. Gravel packing above formation pressure provides a way to by-pass external filter cakes that would not have been removed by any cleanup fluids, by-pass internal filter cake damages, reduces overall drilling and completion costs while maximizing well productivity, improving well life as a result of a reduced potential for plugging due to increased surface areas, and improving production/injection profiles through
25 selective fracing of low permeability sections or stimulation of flow constrained hole sections (i.e. toe of horizontal well).

Brief Description of the drawings

[0017] Other and further objects, features and benefits of the present invention will be further understood by referring to the drawings in which:

- Figure 1 is a conceptual schematic for open-hole shunt-packing of horizontal wells above the fracturing pressure according to the invention; and
- Figure 2 is a schematic, partly in section view, of a portion of a alternate-path tool in an operable configuration within an open-hole wellbore as a gravel fluid is being flowed
5 according to the invention to create a first fracture;

Detailed Description of Preferred Embodiments

[0018] The proposed technique pertains to open-hole completions drilled with a drilling fluid that forms filtercake, and it involves placing the gravel in viscosified slurry with the service tool in the squeeze position using alternate path/shunt screens. The drilling fluid can be either water-
10 based or synthetic/oil-based; however, it is preferably a reservoir drilling fluid so that the filter cake is thin and contains a relatively small amount of fines and from standpoint of long-term migration of drill solid fines into the pack of the formation, the smaller the amount of fines downhole, the better.

[0019] The success of gravel placement with the proposed technique relies on the existence of a
15 low permeability filter cake that keeps fluid loss to a minimum so that dehydration against the formation does not occur until the fracturing pressure is reached and a small fracture penetrates the filter cake and the formation. The method of the present invention deliberately omits the injection of a solid-free fluid or "pad" above fracturing pressure before injecting the gravel slurry. Similarly, no rampant fracturing operation is performed. The idea is to minimize leakoff
20 in the fracture that would cause the gravel/proppant to bridge off and divert the slurry to another section of the open hole without properly packing the created fracture.

[0020] The gravel slurry for use in accordance with the present invention is comprised of a gelled base and gravel. The term "gravel" shall be understood as including any particulate material such as sand, bauxite or ceramic beads, eventually resin coated. The size of the gravel
25 should be selected based on conventional criteria; generally, a gravel having a size ranging between 20 and 40 mesh (U.S. Standard Sieve Series) is preferred. The carrier fluid may be either an aqueous (water or brine) or an oil-base fluid. A variety of known gelling agents can be added to an aqueous base, including natural or synthetic gums such as guar, polysaccharides, in particular galactomannan gums, polymers such as polyacrylamides, biopolymers such as
30 xanthan and cellulose derivatives materials. Modified celluloses and derivatives thereof, in

particular "clean" polymers such as cross-linked hydroxyalkyl cellulose and carboxymethylcellulose are of particular interest.

[0021] Aqueous fluids can also be gelled using viscoelastic surfactants, for instance based upon cationic surfactants such as erucyl methyl bis(2-hydroxyethyl) ammonium chloride (hereinafter referred to as "EMHAC") and zwitterionic surfactants such as betaine surfactants. Carrier fluids gelled with viscoelastic surfactants are polymer-free and therefore less likely to damage the oil reservoir. Moreover, viscoelastic surfactant fluids help to further increase the resistance to leak-off into the fractured section as explained in U.S. Pat. No. 5,551,516, *Hydraulic Fracturing Process and Compositions*, No. 5,964,295, *Methods of Fracturing Subterranean Formations*, and U.S. Pat. No. 5,979,557, *Methods for Limiting the Inflow of Formation Water and for Stimulating Subterranean Formations*, all hereby incorporated by reference. Viscoelastic fluids also contribute to reduce the friction pressure, a point of particular interest since the carrier fluid has to be conveyed along long intervals of pipes of reduced sections.

[0022] In contrast with conventional fracturing, the fluid density of the carrier fluids used in accordance with the present invention should be typically higher to maintain well stability prior to and during the fracturing process at a relatively low injection rate.

[0023] At any time during the whole completion operation, the slurry is generally pumped at well head pressure of less than 1000 psig. Again, this is significantly different from frac-and-pack techniques that involves a step of fracturing at well head pressure up to 5000 psig or even higher. During gravel placement, the service tool is in the squeeze position or annulus closed. The injection rate typically ranges between 2 and 5 barrels per minute (bpm), with a solid concentration typically not exceeding 2 ppa

[0024] The fracturing process involves in the invention is illustrated figure 1. After drilling, an interval of a well to be completed (see figure 1A) penetrates a formation 1 that comprises some shale zones 2, 3 and 4 that are likely to facilitate the formation of bridges. The interface between the wellbore and the formation comprises a zone 5 invaded by a filter cake. A screen 6 is located in the wellbore so that it defines an annulus 8.

[0025] As seen figure 1B, a gravel slurry 9 is pumped within the annulus 8 at a pressure slightly exceeding the formation pressure. Fractures 10, 11 will be initially formed into shales. The use of reduced injection rate might be sufficient the previously fractured section through annular

packing and promote a subsequent fracture initiation point once the rate (and thus pressure) is increased.

5 [0026] Once small propped fractures have been created, thanks to the alternate path technology that allows transport of the gravel slurry through bridges, multiple fractures 12 along the wellbore may be achieved (figure 1C) if a sufficient degree of isolation of the wash-pipe/base-pipe annulus at selected intervals.

10 [0027] In practice, this degree of isolation might be achieved by adding joints to the gravel pack string as illustrated figure 2. The method of the invention is typically carried out with an alternate path tool that comprises a wash pipe. As mentioned earlier, alternate path tools are well known and complete descriptions of their construction and operations can be found in the public literature, therefore the schematic concentrates on some new aspect of the invention.

15 [0028] A typical workstring is comprised of base pipe 12, which is positioned within an outer pipe or shroud 13. The shroud comprises perforated sections. The base pipe and the shroud are usually concentric but it may also be off-center. The workstring further comprises a wash pipe 14. In operation, the wash pipe and the base pipe are fluidly connected to the surface so that two different fluids can be delivered to the well interval.

[0029] The base pipe comprises perforated sections 15 covered by a sand screen 16. It further comprises one or more shunt tubes 17 radially spaced around the sand screen. Each shunt tube comprises openings 18, or preferably at least injectors, which provide alternate flowpaths.

20 [0030] This arrangement defines a first annulus 19 between the washpipe and the base pipe/screen and a second annulus 20 between the base pipe/screen and the base pipe/screen. According to a preferred embodiment of the present invention, the first annulus is divided into discrete sections through the placement of joints 21, for instance PBRs, in the screen assembly and seals on the wash pipe.

25 [0031] In cases where creating fractures above a certain point (e.g., near the heel section of an openhole horizontal well) may be undesirable: a perforated wash pipe can be used to gravel pack the upper sections and induce fractures in the lower sections.

Claims

1. A method for completing an interval of an open-hole wellbore penetrating a subterranean formation, said wellbore being communicating with the formation by way of an interface that comprises at least a filter cake invaded zone, said method comprising
 - 5 a) locating a workstring in the sand screen inside the wellbore, thereby forming an annular between the sand screen and the wellbore;
 - b) pumping a gravel slurry into said annular at a sufficient rate and pressure to form at least a first fracture in a first portion of said interval;
 - 10 c) diverting the gravel slurry to at least a second portion of said annular through alternate flowpaths while providing hydraulic isolation between the first and the second portion of said interval thereby preventing flowback from said second portion to said first portion and resulting extension of the first fracture and forming a second fracture in said second portion of said interval.
2. The method of claim 1, comprising repeating step c) at least once.
- 15 3. The method of claim 1, wherein the well is horizontal or highly deviated.
4. The method of claim 2, wherein the length of the completion interval is at least 300 feet.
5. The method of claim 1, wherein the gravel slurry comprises a viscous base.
6. The method of claim 3, wherein the viscous base comprises a viscoelastic surfactant.
7. The method of claim 1, wherein the first and second fracture extend radially outward from
20 the wellbore a distance within 3 to 150 inches.
8. The method of claim 1, wherein the total volume placement of gravel slurry is about within a range of 150% and 250% of the annular between the sand screen and the wellbore.
9. The method of claim 1, wherein the workstring further includes a washpipe located within
25 the screen, thereby forming a washpipe/screen annulus, whereby seals are located at discrete intervals within said washpipe/screen annulus.

1/1

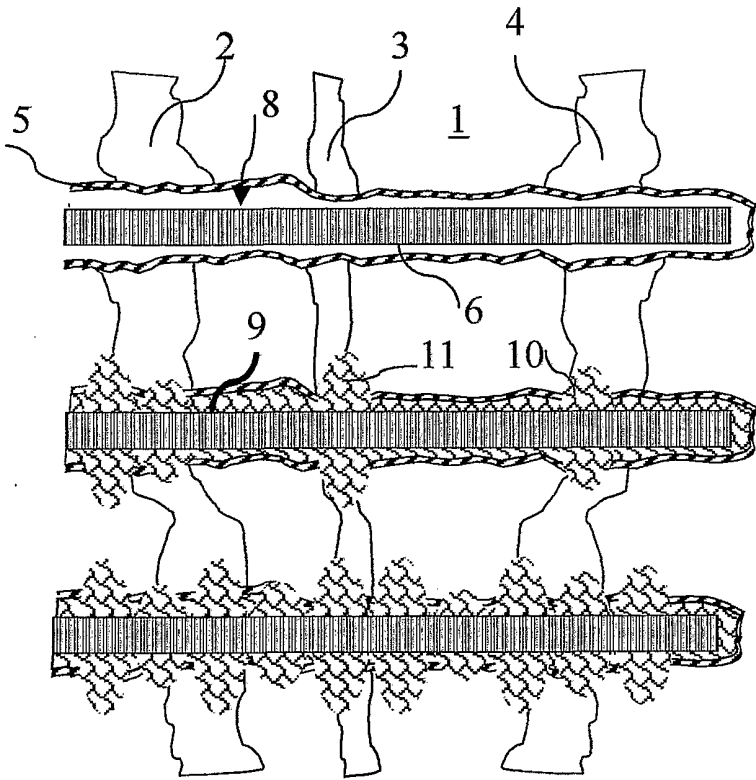

Fig. 1A

Fig. 1B

Fig. 1C

Figure 1

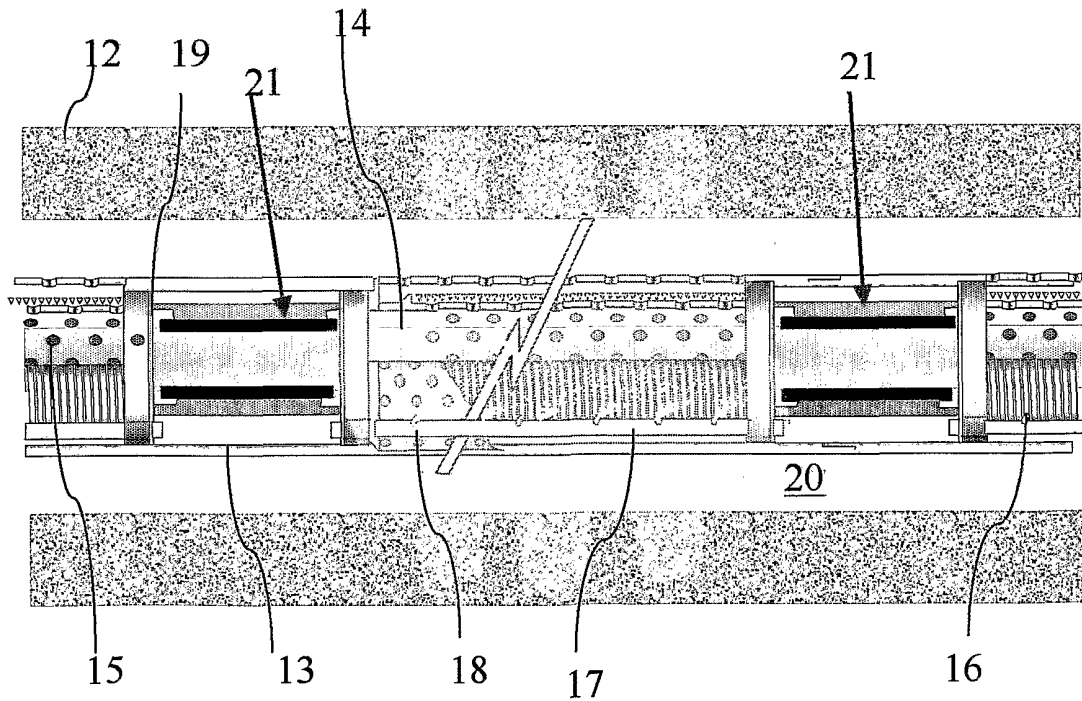

Figure 2

INTERNATIONAL SEARCH REPORT

International Application No
PCT/US 01/29393

A. CLASSIFICATION OF SUBJECT MATTER
IPC 7 E21B43/04 E21B43/267 E21B43/14

According to International Patent Classification (IPC) or to both national classification and IPC

B. FIELDS SEARCHED

Minimum documentation searched (classification system followed by classification symbols)
IPC 7 E21B

Documentation searched other than minimum documentation to the extent that such documents are included in the fields searched

Electronic data base consulted during the international search (name of data base and, where practical, search terms used)

EPO-Internal, WPI Data

C. DOCUMENTS CONSIDERED TO BE RELEVANT

Category *	Citation of document, with indication, where appropriate, of the relevant passages	Relevant to claim No.
P,X	US 6 230 803 B1 (BAYNE CHRISTIAN F ET AL) 15 May 2001 (2001-05-15) column 3, line 48 - line 63 ---	1,5
Y	US 5 375 661 A (DANESHY ABBAS A ET AL) 27 December 1994 (1994-12-27) column 4, line 17 - line 27 column 4, line 64 -column 5, line 2 ---	1-3,5
Y	MORTON B ET AL: "MULTI-ZONE, SINGLE-TRIP GRAVEL PACKS SPEED TIME TO PRODUCTION" OFFSHORE, PETROLEUM PUBLISHING CO. TULSA, US, vol. 52, no. 11, 1 November 1992 (1992-11-01), page 58,60,65 XP000323913 ISSN: 0030-0608 the whole document ---	1-3,5

Further documents are listed in the continuation of box C. Patent family members are listed in annex.

* Special categories of cited documents :

<p>*A* document defining the general state of the art which is not considered to be of particular relevance</p> <p>*E* earlier document but published on or after the international filing date</p> <p>*L* document which may throw doubts on priority claim(s) or which is cited to establish the publication date of another citation or other special reason (as specified)</p> <p>*O* document referring to an oral disclosure, use, exhibition or other means</p> <p>*P* document published prior to the international filing date but later than the priority date claimed</p>	<p>*T* later document published after the international filing date or priority date and not in conflict with the application but cited to understand the principle or theory underlying the invention</p> <p>*X* document of particular relevance; the claimed invention cannot be considered novel or cannot be considered to involve an inventive step when the document is taken alone</p> <p>*Y* document of particular relevance; the claimed invention cannot be considered to involve an inventive step when the document is combined with one or more other such documents, such combination being obvious to a person skilled in the art.</p> <p>*Z* document member of the same patent family</p>
--	--

Date of the actual completion of the international search 6 February 2002	Date of mailing of the international search report 12/02/2002
---	---

Name and mailing address of the ISA European Patent Office, P.B. 5818 Patentlaan 2 NL - 2280 HV Rijswijk Tel. (+31-70) 340-2040, Tx. 31 651 epo nl, Fax: (+31-70) 340-3016	Authorized officer Garrido Garcia, M
--	--

INTERNATIONAL SEARCH REPORT

International Application No

PCT/US 01/29393

C.(Continuation) DOCUMENTS CONSIDERED TO BE RELEVANT		
Category °	Citation of document, with indication, where appropriate, of the relevant passages	Relevant to claim No.
A	US 5 419 394 A (JONES LLOYD G) 30 May 1995 (1995-05-30) cited in the application abstract -----	1-9
P,A	US 6 220 345 B1 (TIBBLES RAYMOND J ET AL) 24 April 2001 (2001-04-24) cited in the application the whole document -----	1
P,A	EP 1 132 571 A (HALLIBURTON ENERGY SERV INC) 12 September 2001 (2001-09-12) paragraph '0053! -----	1

INTERNATIONAL SEARCH REPORT

International Application No PCT/us 01/29393

Patent document cited in search report	Publication date	Patent family member(s)	Publication date
US 6230803	B1	15-05-2001	NONE
US 5375661	A	27-12-1994	NONE
US 5419394	A	30-05-1995	AU 686705 B2 12-02-1998
			AU 1185395 A 13-06-1995
			CA 2174769 A1 01-06-1995
			EP 0729543 A1 04-09-1996
			NO 962070 A 04-06-1996
			RU 2133325 C1 20-07-1999
			WO 9514844 A1 01-06-1995
US 6220345	B1	24-04-2001	AU 6780800 A 19-03-2001
			WO 0114691 A1 01-03-2001
EP 1132571	A	12-09-2001	AU 1840701 A 13-09-2001
			EP 1132571 A1 12-09-2001
			NO 20011114 A 10-09-2001