

(12) UK Patent Application (19) GB (11) 2 321 108 (13) A

(43) Date of A Publication 15.07.1998

(21) Application No 9700225.7

(22) Date of Filing 08.01.1997

(71) Applicant(s)
David Alan Woodfield
Tudor Croft, Bamford Road, Bloxwich, WALSALL,
West Midlands, WS3 3RX, United Kingdom

(72) Inventor(s)
David Alan Woodfield

(74) Agent and/or Address for Service
Forrester Ketley & Co
Chamberlain House, Paradise Place, BIRMINGHAM,
B3 3HP, United Kingdom

(51) INT CL⁶
G06K 11/18

(52) UK CL (Edition P)
G1N NAEDR NAQB N1A4 N1D5 N3S10 N3S4 N7N N7S

(56) Documents Cited
GB 2247938 A GB 2133889 A GB 2055209 A
GB 1083222 A GB 0872152 A

(58) Field of Search
UK CL (Edition O) **F2Y YTA , G1N NAEDR NAQB**
INT CL⁶ **G06K 11/18 11/20**

(54) Abstract Title
Input device for inputting positional information

(57) A device 10 for inputting positional information comprises a first member 11 having at least two isolated electrically conducting parts (four parts 13-16 as shown) and a second electrically conducting member 12 adjacent to and capacitively coupled to the first member, the two members being relatively moveable such that the proportions of the respective parts 13-16 of the first member 11 which are in overlapping relationship with the second member 12 may be varied, an oscillator means 25 to provide a first waveform signal to a first part or parts of the first member and a second waveform signal of different phase to a second part or parts of the first member, and a comparator 40 to compare the relative phase of a signal from the capacitively coupled second member 12 with that of the first or second waveform signal to provide a device output signal 50. The device shown provides X and Y axis coordinate information, but other arrangements including a linear device are envisaged.

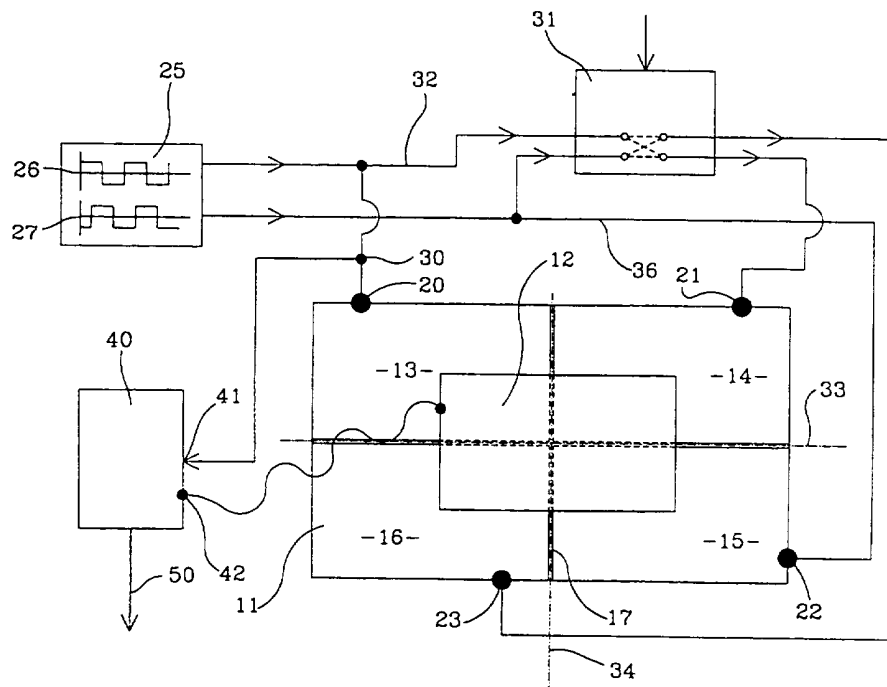
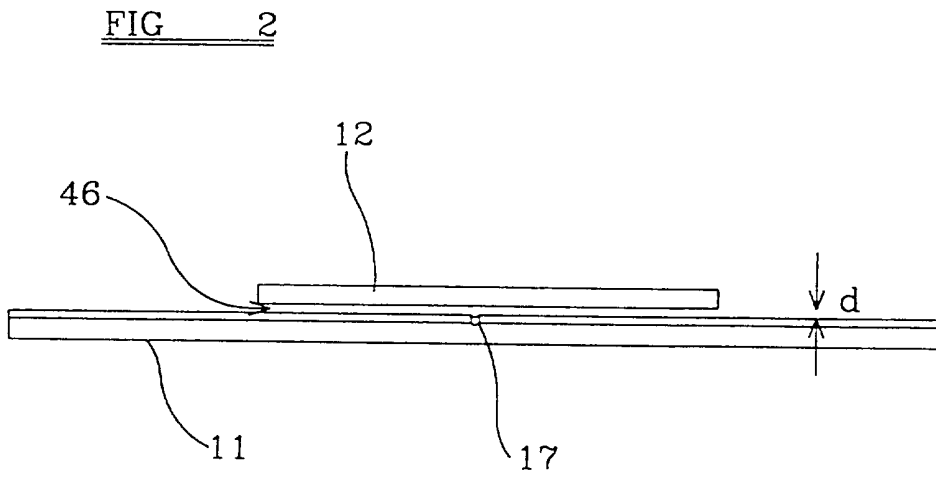
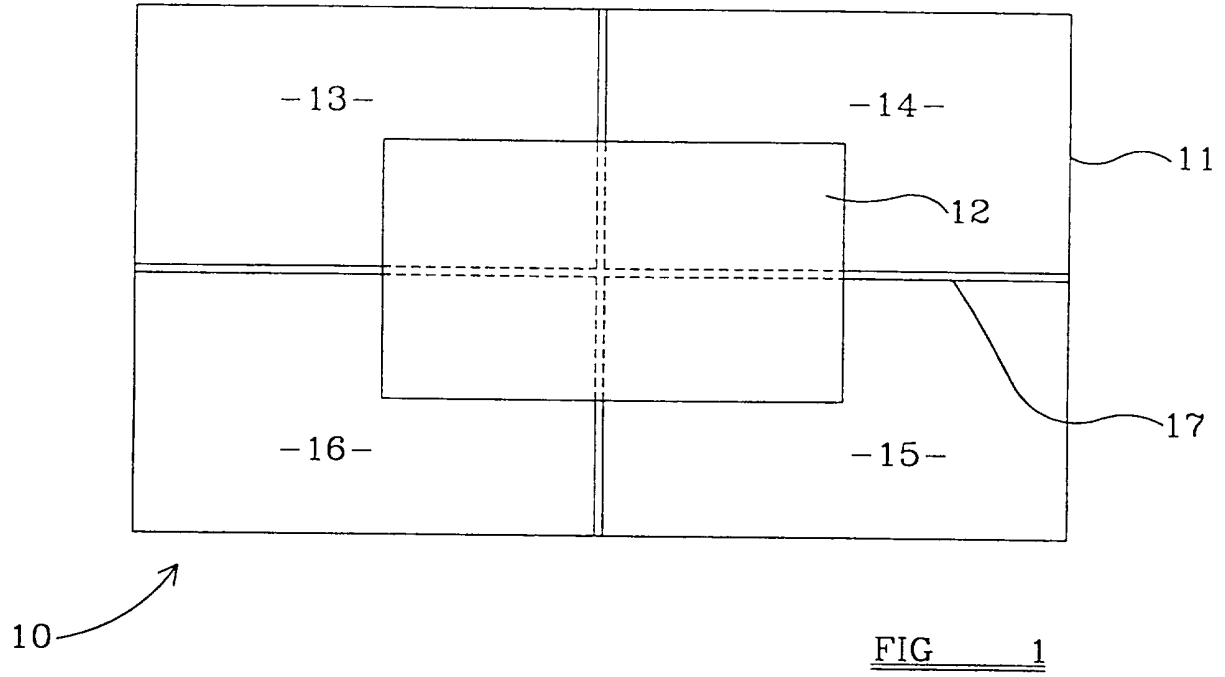

FIG 3

GB 2 321 108 A



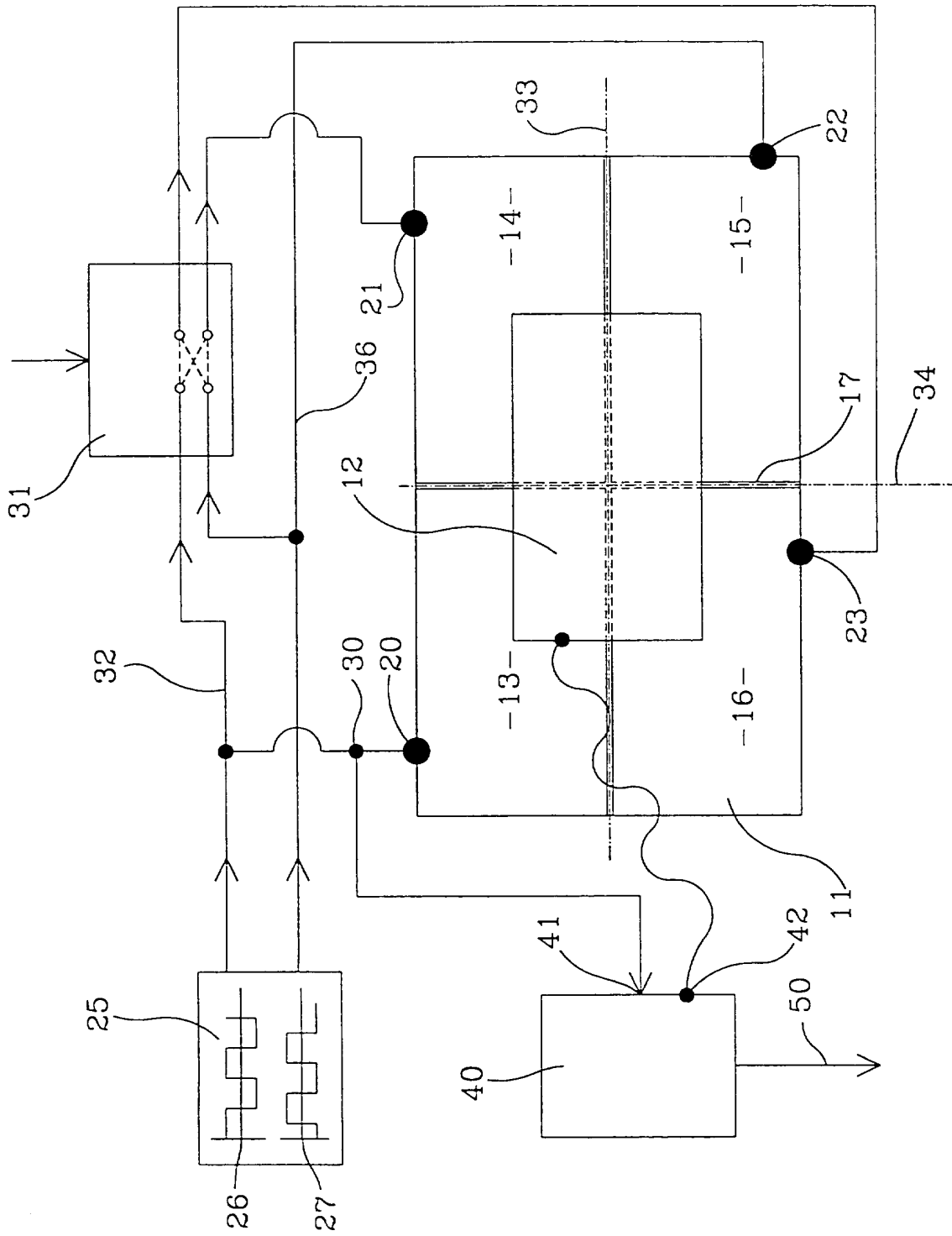

FIG 3

Title: Input Device for Inputting Positional Information

Description of Invention

This invention relates to an input device for inputting positional information particularly but not exclusively for inputting positional information into a computer, controller, game playing console or the like.

Known inputting devices tend to rely on wiping/rolling contacts and/or resistive films, each of which are prone to wear.

According to one aspect of the present invention I provide an input device for inputting positional information comprising a first member having at least two isolated electrically conducting parts, and a second electrically conducting member adjacent to and capacitively coupled to the first member, the first and second members being relatively movable such that the proportions of the respective parts of the first member in overlapping relationship with the second member may be varied, oscillator means to provide a first waveform signal to one of the parts of the first member and a second waveform signal of different phase to the first waveform signal, to the second part of the first member comparator means to compare the relative phases of the first or second waveform signal and a signal from the capacitively coupled second member to provide a device output signal.

Thus an input device is provided which relies on the capacitive coupling of the first and second members and the need for wiping/rolling contacts and/or resistive films, is avoided.

Conveniently the first waveform signal is a sine wave, and preferably is 90° out of phase with the second waveform signal which may be a sine wave of the same frequency.

In one embodiment the first and second members may be generally flat and parallel with there being an air space or some kind of insulation between them. Thus conveniently at least one of the first and second members may

comprises a, or an area of a, printed circuit board, which may or may not have other functions.

However, the first and second members may be of other complimentary configurations, provided that the distance between the first and second members is retained generally constant during relative movement of the first and second members.

The first and second members may be relatively movable generally linearly, but alternatively, the members may be relatively moveable about an axis or axes.

The first member may comprises at least three isolated electrically conducting parts, there being switch means to provide the waveform signal or signals selectively to one or more different parts of the member so that positioned information relative to more than one axis can be obtained.

However, particularly where the device is used to provide positional information along two (x-y) axes, the first member may comprises at least four isolated electrically conducting parts arranged in a generally rectangular array.

Thus the four parts may be isolated from each other by means of a cross shaped insulating element.

In each case where a switch means is provided, the switch means may comprise an electronic switch which provides the waveform signal to the different parts automatically and in sequence.

According to a second aspect of the invention I provide a method of obtaining positional information utilising a device according to any one of the preceding claims comprising the steps of providing the first waveform signal to one of the parts of the first member, and the second waveform signal of the second part of the first member, comparing the relative phases of the first or second waveform signals and a signal from the capacitively coupled second member, to obtain a device output signal.

The invention will now be described with reference to the accompanying drawings in which

FIGURE 1 is an illustrative plan view of part of a device in accordance with the invention;

FIGURE 2 is an illustrative end view of the part of the device of figure 1;

FIGURE 3 is a diagram illustrating a possible electronic circuit for the device of figures 1 and 2.

Referring to the drawings an input device 10 for inputting positional information into a computer, controller, game playing console or the like comprises a first member 11, and a relatively moveable second member 12. The first member 11 comprises in this example, four isolated electrically conducting generally flat parts 13, 14, 15 and 16 arranged in a generally rectangular array such that the parts 13 to 16 are isolated from one another by a generally cross shaped isolating element indicated at 17.

In this example, the second part 12 is moveable over the first part 11 by means hereinafter explained. The total area of the first part 11 is at least four times that of the area of the second member 12 in this example.

Conveniently the first member 11 is made from single sided printed circuit board material or is otherwise a mixed construction of conducting and insulating parts. The first part 11 may comprise a discrete member, or make comprise part of or an extension to an existing printed circuit board.

Each of the parts 13 to 16 of the first member 11 is provided with a connection 20 to 23 respectively.

The device 10 further comprises a quadrature oscillator signal source 25 which produces two substantially identical output signals 26 and 27, which are sine waves 90° out of phase with one another. One of the signals, namely the signal indicated at 26, is connected via a conductor 30 to the terminal 20 of the first part 13 of the first member 11. The signal 26 may, in dependence upon the condition of an electronic switch 31, simultaneously be connected via a conductor 32 either to the second part 14 of the first member 11, or the fourth part 16 of the first member 11 depending upon whether the device 10 is operating to provide

positional information along an X axis indicated at 33, or a Y axis indicated at 34. The second signal 27 is connected via a conductor 36 to terminal 22 of the third part 15 of the first member 11, and depending upon the condition of the electronic switch 31, may simultaneously be connected either to terminal 21 of the second part of 14 of the first member 11, or to terminal 23 of the fourth part 16 of the first member 11.

The device 10 further comprises a comparator means indicated at 40 which has a first input 41 connected to conductor 30 carrying the first signal 26 from the quadrature oscillator means 25 to the first member 11, and a second input 42 connected in this example, via a flexible wire 43 to the second member 12.

Of course, the second member 12 may be connected by any other desired kind of conductor to the input 42, such as conductor incorporating one or more wiping contacts or the like.

The second member 12 may also comprise a printed circuit board and is positioned adjacent to the first member 11 with there being an air gap 46 between the first 11 and second 12 members.

The second member 12 may be constrained by any desired known means to move relative to the first member 11 such that distance d between the first 11 and second 12 members remains substantially constant and the first member 11 and second member 12 remain substantially parallel.

It will be appreciated therefore that as the second member 12 is moved over the first member that the proportions of the respective parts 13-16 of the first member 11 in overlapping relationship with the second member 12 will be varied.

The air in the air gap 46 between the first 11 and second 12 members is a di-electric and as such, the first and second members 11, 12 will be capacitively coupled.

Of course, if desired, instead of providing an air gap between the first 11 and second 12 members, an insulating material may be provided. In one

example, a polythene or other thin membrane may be placed on the first member 11, and the second member may carry a conductive foam rubber which is moved over the first member 11 as the second member 12 moves. In that way, the spacing between the first and second members 11,12 would be retained constant during movement of the second member 12. Other arrangements are no doubt possible.

When the electronic switch 31 is in a condition such that the first signal 26 is connected to the two parts 13 and 16 and the second signal 27 is connected to the second and third parts 14, 15, movement of the second member 12 relative to the X axis 33 (e.g. along the Y axis 34) will thus change the phase of the signal induced in the second member 12 by virtue of its capacitive coupling with the first member 11. Thus the comparator means 40, by comparing the relative phases of the first signal 26 and the signal from the second member 12, may provide an output signal 50 indicative of the relative position of the second member 12 to the first member 11 relative to the X axis 33. This assumes that the first and second signals 26,27 are not in anti-phase with each other.

When the electronic switch 31 is in a condition such that first signal 26 from the quadrature oscillating means 35 is connected to parts 13 and 14 of the first member 11, and the second signal is connected to third and fourth parts 15 and 16 of the first member, then the output signal 50 from the phase comparator 40 will be indicative of the relative position of the second part 12 relative to the Y axis 34.

When the device 10 is operating such that the output signal 50 is indicative of the position of the second member 12 relative to the X axis 33, it will be appreciated that movement of the second member 12 relative to the Y axis e.g. along the X axis 33 will not affect the phase of the signal arising in the second member 12 by virtue of its capacitive coupling to the first member 11, and conversely, when the output signal 50 is indicative of the position of the second member 12 relative to the Y axis 34, movement of the second member 12 relative to the X axis 33 e.g. along the Y axis 34 will not affect the phase if the signal axis

in the second member 12.

The output signal 50 from the phase comparator 40 thus may, depending upon the condition of the electronic switch 31, be indicative of position of the second member 12 along the X or Y axes 33, 34.

The electronic switch 31 may be manually controlled but most conveniently, the electronic switch 31 is arranged to provide the respective first and second signals 26, 27 to the different parts 13 to 16 of the first member 11 automatically and in sequence. A multiplexer or like arrangement may therefore be provided as the electronic switch 31 and it will be appreciated that the output signal 50 may need appropriately to be switched to different inputs of a computer controller, game console or the like, which may thus utilise the output signal 50 appropriately to determine X-Y axis positional information.

The phase comparator 40 may compare the relative phases of the signals at the two inputs 41 and 42 by any applicable means such as a (software) timing loop or (hardware) ASIC counter or the like.

It will be appreciated that in many items of electronic equipment or other apparatus which contain electronic control means, there will be an existing microcontroller or ASIC, and that the existing microcontroller or ASIC may be utilised both to obtain one or more waveform signals such as signals 26 and 27 for use in the device 10, and that the microcontroller or ASIC may also comprise the means necessary to determine the phase difference between the waveform signal provided to the first member 11, and the signal from the capacitively coupled second member 12.

It will be appreciated that the oscillator signal source 25 may provide appropriate waveform signals to a plurality of position sensing devices. Thus for example in a graphic equalizer which may have a substantial number of individual channels, thirty say, only one oscillator would be required. A dedicated comparator means may be provided for each positional sensor, or using a multiplexing type arrangement, a single comparator may be used for each of the positional sensing devices.

Various modifications may be made without departing from the scope of the invention.

In particular, the present invention has been described in the embodiment above with reference to a device for obtaining positional information along mutually generally orthogonal X and Y axis 33 and 34. The invention may be utilised to obtain omnidirectional information only, and that direction may be linear or otherwise. For example, a conventional slider type control having wiping contacts may be replaced by a device in accordance with the invention in which the first member has only two parts which are isolated electrically conducting parts. Alternatively, the device may provide positional information relative to three axes at 120° to one another in which case the first member may comprise three isolated electrically conducted parts in a suitably array.

In each such case, preferably the comparator means 40 measures phase difference between the two signals at the inputs 41 and 42, and two signals 26 and 27 preferably sine waves of the same wavelength and amplitude but out of phase but not in anti-phase are required. Preferably the two signals 26,27 are 90° out of phase.

In another arrangement though, where omnidirectional positional information is required, only one waveform signal may be provided to one of the two parts, with the other part of the first member grounded. In that event, the comparator means 40 may be adapted to measure differences in amplitude between the waveform signal and the signal arising in the second member 12 by virtue of its capacitive coupling.

It is envisaged that a device in accordance with figures 1 to 3 may be constructed in which the first member 11 has an area of about 25 x 20 mm. The quadrature oscillating means 25 may generate a sine wave signal or other suitable wave form, at a frequency of about 10 kHz. Stability of frequency is not critical but should remain stable whilst positional movement of the second member 12 relative to the first member is performed. The quadrature or other oscillator means 25 may generate the waveform signal or signals 26, 27 digitally, and the

signals may then be filtered to provide a sine wave or other waveform as desired. Alternatively the oscillator signal or signals 26/27 may be generated by a linear oscillator.

Whereas it is preferred for the distance d between the moving member 12 and the fixed member 11 to remain generally constant, slight variations in distance d during second member movement need not have a severe effect on the positional movement determined provided that the air gap 46 is sufficiently great.

The features disclosed in the foregoing description, or the following claims, or the accompanying drawings, expressed in their specific forms or in terms of a means for performing the disclosed function, or a method or process for attaining the disclosed result, as appropriate, may, separately or in any combination of such features, be utilised for realising the invention in diverse forms thereof.

CLAIMS

1. An input device for inputting positional information comprising a first member having at least two isolated electrically conducting parts, and a second electrically conducting member adjacent to and capacitively coupled to the first member, the first and second members being relatively movable such that the proportions of the respective parts of the first member in overlapping relationship with the second member may be varied, oscillator means to provide a first waveform signal to one of the parts of the first member and a second waveform signal of different phase to the first waveform signal, to the second part of the first member comparator means to compare the relative phases of the first or second waveform signal and a signal from the capacitively coupled second member to provide a device output signal.
2. A device according to claim 1 wherein the first waveform signal is 90° out of phase with the second waveform signal.
3. A device according to any one of the previous claims wherein the first and second members are generally flat and parallel with there being an air space or insulation between them.
4. A device according to any one of the preceding claims wherein the first and second members are relatively movable generally linearly.
5. A device according to any one of the preceding claims wherein the first member comprises at least three isolated electrically conducting parts, there being switch means to provide the waveform signal or signals selectively to one or more different parts of the member.

6. A device according to claim 5 wherein the first member comprises at least four isolated electrically conducting parts arranged in a generally rectangular array.
7. A device according to claim 5 or claim 6 wherein the switch means comprises an electronic switch which provides the waveform signal to the different parts automatically and in sequence.
8. A device according to any one of the preceding claims wherein at least one of the first and second members comprises a , or an area of a, printed circuit board.
9. A device substantially as hereinbefore described with reference to and as shown in the accompanying drawings.
10. A method of obtaining positional information utilising a device according to any one of the preceding claims comprising the steps of providing the first waveform signal to one of the parts of the first member, and the second waveform signal of the second part of the first member, comparing the phases of the first or second waveform signals and a signal from the capacitively coupled second member, to obtain a device output signal.
11. A method of obtaining positional information substantially as hereinbefore described with reference to the accompanying drawings.
12. Any novel feature or novel combination of features described herein and/or in the accompanying drawings.

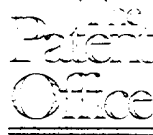

11

Application No: GB 9700225.7
Claims searched: 1-11

Examiner: M. G. Clarke
Date of search: 3 April 1997

Patents Act 1977
Search Report under Section 17

Databases searched:

UK Patent Office collections, including GB, EP, WO & US patent specifications, in:

UK CI (Ed.O): F2Y YTA; G1N NAEDR, NAQB

Int CI (Ed.6): G06K 11/18, 11/20

Other: -----

Documents considered to be relevant:

Category	Identity of document and relevant passage	Relevant to claims
Y	GB2247938A D.R.Sherriff et al - see esp. Figs. 1 to 5	6,8
X	GB2133889A Lucas Industries - whole document but see especially p.1 line 128 to p.2 line 32	1-3,8
Y		6
Y	GB2055209A Jungheinrich etc - see esp. Figs. 1, 2	6,8
X	GB1083222 Sanders Associates - whole document	1-3 at least
Y		6,8
X	GB872152 AEI Ltd - see esp. page 3 lines 51-68	1 at least

X	Document indicating lack of novelty or inventive step	A	Document indicating technological background and/or state of the art.
Y	Document indicating lack of inventive step if combined with one or more other documents of same category.	P	Document published on or after the declared priority date but before the filing date of this invention.
&	Member of the same patent family	E	Patent document published on or after, but with priority date earlier than, the filing date of this application.